



US00D838017S

(12) **United States Design Patent** (10) **Patent No.:** **US D838,017 S**
Nurnberger et al. (45) **Date of Patent:** **** Jan. 8, 2019**

(54) **REAR LIGHT FOR AN AUTOMOBILE**

FOREIGN PATENT DOCUMENTS

(71) Applicant: **Aston Martin Lagonda Limited**,
Warwick (GB)

DE 2727517 A1 12/1978
DE 4321969 A1 2/1994

(Continued)

(72) Inventors: **Miles Nurnberger**, Warwick (GB);
Sam Holgate, Warwick (GB)

OTHER PUBLICATIONS

(73) Assignee: **Aston Martin Lagonda Limited** (GB)

“2009 Aston Martin Vantage 2-door Coupe Man Grille”. Found online Mar. 21, 2016 at motorauthority.com. Page dated c. 2009. Retrieved from http://www.motorauthority.com/image/100236184_2009-aston-martin-vantage-2-door-coupe-man-grille.

(Continued)

(**) Term: **15 Years**

(21) Appl. No.: **29/589,618**

Primary Examiner — Marcus A Jackson

(22) Filed: **Jan. 3, 2017**

(74) *Attorney, Agent, or Firm* — Dorsey & Whitney LLP

(30) **Foreign Application Priority Data**

(57) **CLAIM**

Jul. 5, 2016 (EM) 003295096-0001
Jul. 5, 2016 (EM) 003295096-0002

The ornamental design for a rear light for an automobile, as shown and described.

DESCRIPTION

(51) **LOC (11) Cl.** **26-06**

(52) **U.S. Cl.**
USPC **D26/28**

(58) **Field of Classification Search**
CPC B60Q 9/13; B60Q 9/135; B60Q 9/1375;
F21S 48/00; F21S 48/10; F21S 48/115;
F21S 48/225; F21S 48/1233; F21S
48/1266; F21S 48/1388; F21S 48/2268;
F21V 21/04

FIG. 1 is a front elevation view of a rear light for an automobile in accordance with the present design; FIG. 2 is a rear elevation view thereof; FIG. 3 is a top plan view thereof; FIG. 4 is a left side elevation view thereof; FIG. 5 is a right side elevation view thereof; FIG. 6 is a rear perspective view thereof; FIG. 7 is a front perspective view thereof; FIG. 8 is an enlarged rear elevation view thereof; FIG. 9 is an enlarged right side elevation view thereof; and, FIG. 10 is an enlarged rear perspective view thereof.

See application file for complete search history.

The broken lines show an automobile for environment and form no part of the claimed design.

(56) **References Cited**

U.S. PATENT DOCUMENTS

D373,432 S * 9/1996 Wu D26/28
D385,982 S * 11/1997 Moore D26/28
D447,825 S * 9/2001 Lee D26/28
D489,144 S * 4/2004 Dalton, Jr. D26/28

Any combination of the illustrated features may be claimed in this application or a continuing application claiming priority to this application by converting any of the solid lines to broken lines, any of the broken lines to solid lines, or any combination thereof.

(Continued)

1 Claim, 8 Drawing Sheets

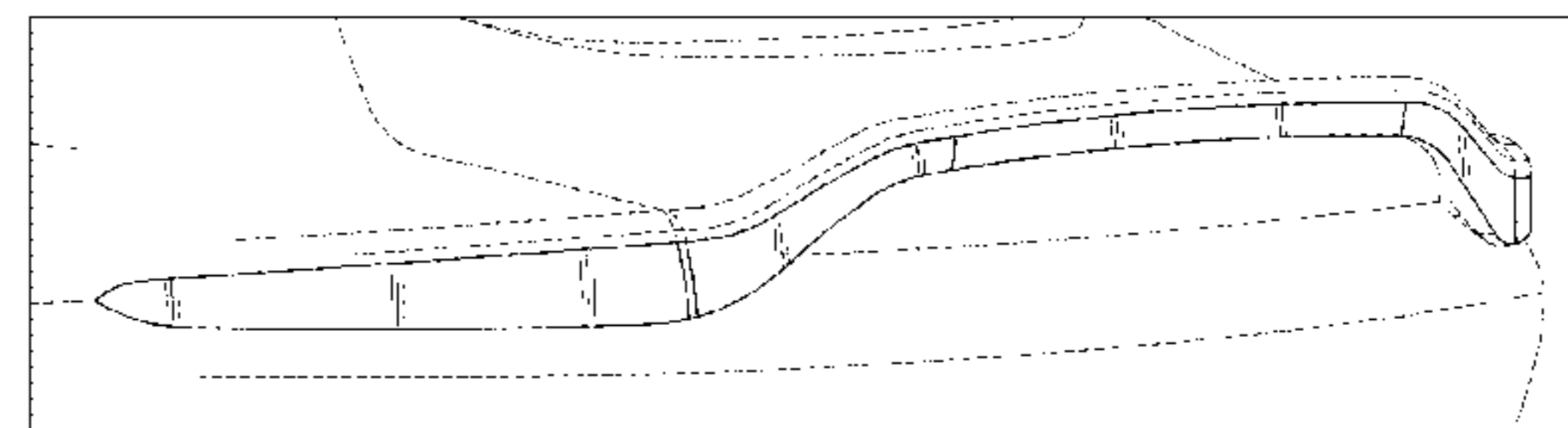
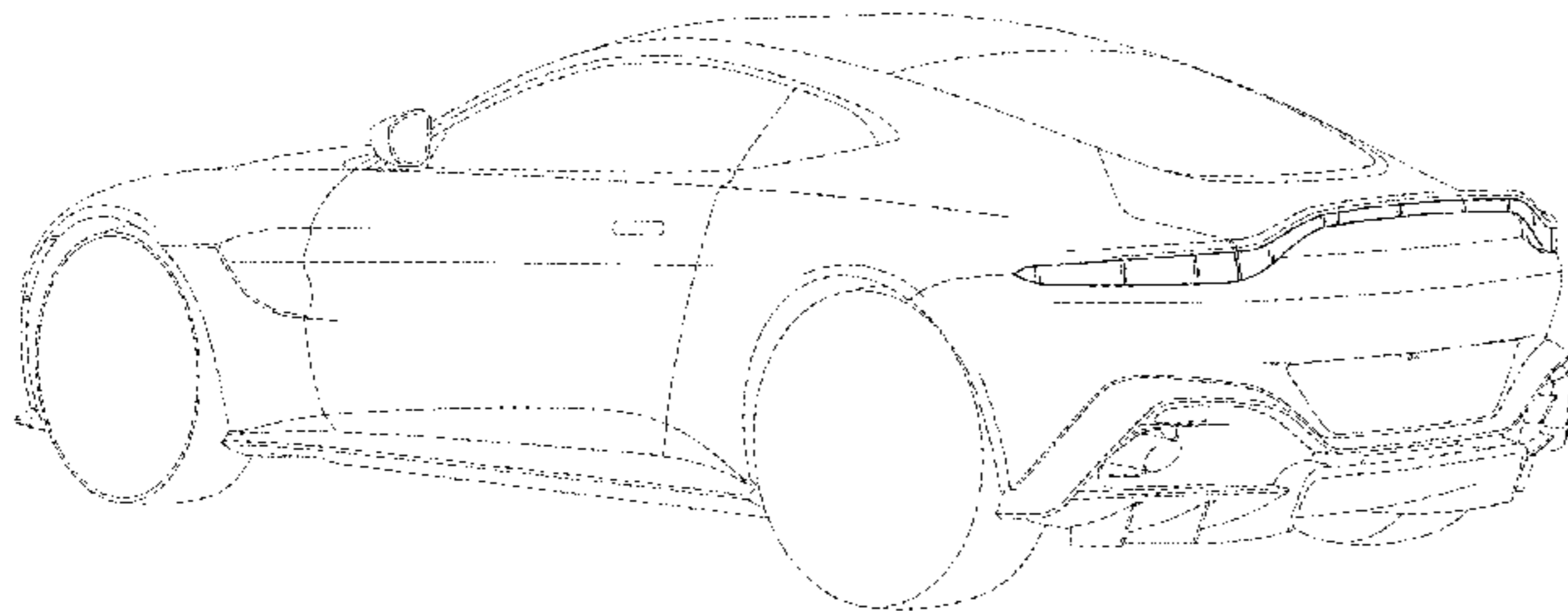

(56)

References Cited

U.S. PATENT DOCUMENTS

D620,396 S	7/2010	Reichman et al.	
D626,466 S	11/2010	Reichman et al.	
D629,718 S	12/2010	Reichman et al.	
D629,719 S	12/2010	Reichman et al.	
D629,725 S	12/2010	Reichman et al.	
D630,140 S	1/2011	Reichman et al.	
D637,746 S	* 5/2011	Kong	D26/28
D670,640 S	11/2012	Reichman et al.	
D684,711 S	* 6/2013	Chen	D26/28
D687,348 S	8/2013	Nurnberger	
D689,812 S	9/2013	Reichman et al.	
D692,800 S	11/2013	Wiltshire	
D704,102 S	5/2014	Nurnberger	
D704,601 S	5/2014	Nurnberger	
D708,369 S	* 7/2014	Song	D26/28
D711,025 S	* 8/2014	Gueler	D26/28
D726,079 S	4/2015	Reichman et al.	
D727,804 S	4/2015	Nurnberger	
D730,777 S	6/2015	Nurnberger	
D739,789 S	9/2015	Payne	
D740,725 S	10/2015	Payne	
D758,247 S	6/2016	Nurnberger et al.	
D766,474 S	9/2016	Holgate et al.	
D772,128 S	11/2016	Platt	
D774,950 S	12/2016	Holgate et al.	
D774,995 S	12/2016	Holgate et al.	
D777,070 S	1/2017	Nurnberger	
D778,790 S	2/2017	Nurnberger	
D780,632 S	3/2017	Nurnberger	
D780,633 S	3/2017	Payne et al.	
D780,634 S	3/2017	Segui et al.	
D780,636 S	3/2017	Kahn	
D785,525 S	5/2017	Nurnberger	
D786,155 S	5/2017	Holgate et al.	
D786,744 S	5/2017	Nurnberger et al.	
D791,375 S	* 7/2017	Lichte	D26/28
D796,404 S	9/2017	Nurnberger	
D800,619 S	10/2017	Platt	
D801,558 S	* 10/2017	Segui	D26/28
D802,183 S	* 11/2017	Leutiger	D26/28

FOREIGN PATENT DOCUMENTS

EM	0002129230001	10/2004
EM	0002129230002	10/2004
EM	0010678390001	1/2009
EM	0016500520001	12/2009
EM	0016746310001	2/2010
EM	0016746310002	2/2010
EM	0016746310003	2/2010
EM	0016746310005	2/2010
EM	0019998480001	2/2012
EM	0019998480003	2/2012
EM	0020336210001	4/2012
EM	0020336210003	4/2012
EM	0020336210005	4/2012
EM	0020336210006	4/2012
EM	0020479770002	5/2012
EM	0021714880001	1/2013
EP	0896892 A1	2/1999
EP	0906863 A2	7/1999
EP	2476603 A2	7/2012
GB	2327912 A	2/1999
GB	3013456	7/2003
GB	2396881 A	7/2004
GB	3024223	3/2006
JP	1400694	8/2010
JP	1444677	6/2012
WO	0212028 A1	2/2002

OTHER PUBLICATIONS

“2011 Aston Martin One-77.” Electronic Brochure., Jun. 22, 2010 [online], [retrieved on Sep. 5, 2014]. Retrieved from theInternet

<URL: http://www.auto-brochures.com/makes/Aston_Martin/one-77/Aston%20Martin_int%20one-77.pdf>.

“2012 Aston Martin Virage”, Online Review dated Mar. 21, 2012 (Retrieved from the Internet Jan. 20, 2016), Available at <http://www.autoblog.com/2012/03/21/2012-aston-martin-virage-review-road-test>.

“Aston Martin Sedan/Lagonda Spy Photos”. Found online Mar. 21, 2016 at forums.nasioc.com. Page dated May 9, 2014. Retrieved from <http://forums.nasioc.com/forums/showthread.php?t=2628222>.

“Cars Wheels Design”, Online Blog dated Oct. 13, 2011 (Retrieved from the Internet Jan. 20, 2016), Available at <http://wheelsdesigns.blogspot.com/2011/10/aston-martin-wheels.html>.

“eAutoZine: Aston Martin Lagonda Returns in Summer 2014”. Found online Mar. 21, 2016 at eautozine.com. Page dated Jun. 22, 2014. Retrieved from <http://www.eautozine.com/page/4/>.

1976 and 1987 Aston Martin Lagonda, [online], [site visited Jul. 24, 2014], Available from Internet, <URL: <http://www.astonmartin.com/heritage/past-models/lagonda>>, 2 pages.

2003 Aston Martin DB7 Vantage, [online], [site visited Jan. 3, 2014], Available from Internet, <URL: <http://www.conceptcarz.com/view/photo/291097,6877/2003-Aston-Martin-DB7-Vantage.aspx>>, 2 pages.

2011 Aston Martin Rapide, [online article Feb. 4, 2010, [site visited Jan. 3, 2014], Available from Internet, <URL: http://www.roadandtrack.com/car-reviews/first-drives/photos-2011-aston-martin-rapide?click=main_sr#slide-1>, 6 pages.

2014 Aston Martin Rapide S, announced Dec. 30, 2013, [online], [site visited Jan. 3, 2014], Available from Internet, <URL: <http://www.astonmartin.com/en-us/cars/rapide-s>>, 35 pages.

Aston Martin 2013, “Aston Martin Centenary Celebration Programme,” 2013; 204 pages.

Aston Martin DB9 Brochure; Website[online]: <http://www.auto-brochures.com>, Jan. 27, 2012 [retrieved on Oct. 22, 2013]. Retrieved from the internet: <URL: http://www.auto-brochures.com/makes/Aston_Martin/db9/Aston%20Martin_int%20DB9_1.pdf>; 41 pages.

Aston Martin IDBS Brochure; Website[online]: <http://www.auto-brochures.com>, Jan. 27, 2012 [retrieved on Oct. 22, 2013]. Retrieved from the internet: <URL: http://www.auto-brochures.com/makes/Aston_Martin/dbs/Aston%20Martin_int%20DBS_1.pdf>; 62 pages.

Aston Martin, “Vulcan”, <http://www.astonmartin.com/vulcan> [Retrieved from the Internet on Oct. 21, 2016], 2 Pages.

European Patent Office; PCT International Preliminary Examination Report dated Dec. 5, 2002; PCT/GB01/03563; 11 pages.

European Patent Office; PCT International Search Report dated Nov. 21, 2001; PCT/GB01/03563; 3 pages.

European Patent Office; PCT Written Opinion dated Aug. 21, 2002; PCT/GB01/03563; 5 pages.

European Patent Office; PCT Written Opinion dated Mar. 6, 2002; PCT/GB01/03563; 5 pages.

Youtube, “First Look: Aston Martin Vulcan—Geneva 2015”, <https://www.youtube.com/watch?v=weY6qeOJIBe>, Published Mar. 5, 2015, 2 Pages.

“Extremely Striking ‘Bespoke’ Aston Martin Super-Saloon Spied”. Found online Mar. 21, 2016 at forums.vwvortex.com. Page dated May 8, 2014., Retrieved from <http://forums.vwvortex.com/showthread.php?6969673-Extremely-striking-quot-Bespoke-quot-Aston-Martin-super-saloon-spied-Built-by-0-by-Aston-Martin-will-be-very-limited-run-could-be-badged-Lagonda>.

Carrion, Annette. “2014 Aston Martin Vanquish Volante Neiman Marcus . . .” European Car Web., Jun. 22, 2010 [online], [retrieved on Sep. 5, 2014]., Retrieved from the Internet <URL: http://www.europeancarweb.com/news/1311_2014_aston_martin_vanquish_volante_neiman_marcus_edition/photo_06.html>.

Vijayenthiran, Viknesh. “Aston Martin Builds and Sells Two CC100 Speedsters: Report.” Motor Authority., Jul. 26, 2013 [online], [retrieved on Sep. 5, 2014]., Retrieved from the Internet <URL: http://www.motorauthority.com/news/1085797_aston-martin-builds-and-sells-two-cc100-speedsters-report>.

2008 Aston Martin DB9 Grill & Front View Photo. Website[online]: <http://www.motortrend.com>, Jun. 12, 2008 [retrieved on Oct. 22,

(56)

References Cited

OTHER PUBLICATIONS

2013], Retrieved from the internet: <URL: http://www.motortrend.com/cars/2008/aston_martin/db9/photos/exterior/grill_front_view.htm/>; 1 page.

U.S. Appl. No. 29/530,866, filed Jun. 19, 2015.
U.S. Appl. No. 29/534,648, filed Jul. 30, 2015.
U.S. Appl. No. 29/534,727, filed Jul. 30, 2015.
U.S. Appl. No. 29/542,940, filed Oct. 19, 2015.
U.S. Appl. No. 29/573,909, filed Aug. 10, 2016.
U.S. Appl. No. 29/583,268, filed Nov. 3, 2016.
U.S. Appl. No. 29/583,272, filed Nov. 3, 2016.
U.S. Appl. No. 29/583,278, filed Nov. 3, 2016.
U.S. Appl. No. 29/584,625, filed Nov. 16, 2016.
U.S. Appl. No. 29/584,629, filed Nov. 16, 2016.
U.S. Appl. No. 29/589,582, filed Jan. 3, 2017.
U.S. Appl. No. 29/589,583, filed Jan. 3, 2017.
U.S. Appl. No. 29/589,586, filed Jan. 3, 2017.
U.S. Appl. No. 29/589,621, filed Jan. 3, 2017.
U.S. Appl. No. 29/595,005, filed Feb. 24, 2017.
U.S. Appl. No. 29/604,102, filed May 15, 2017.
U.S. Appl. No. 29/542,940, filed Oct. 19, 2015, Kahn.
U.S. Appl. No. 29/573,909, filed Aug. 10, 2016, Cooper.
U.S. Appl. No. 29/582,156, filed Oct. 25, 2016, Earley.
U.S. Appl. No. 29/582,165, filed Oct. 25, 2016, Earley.
U.S. Appl. No. 29/582,167, filed Oct. 25, 2016, Earley.

U.S. Appl. No. 29/582,170, filed Oct. 25, 2016, Earley.
U.S. Appl. No. 29/583,268, filed Nov. 3, 2016, Nurnberger et al.
U.S. Appl. No. 29/583,272, filed Nov. 3, 2016, Nurnberger et al.
U.S. Appl. No. 29/583,278, filed Nov. 3, 2016, Nurnberger et al.
U.S. Appl. No. 29/584,625, filed Nov. 16, 2016, Nurnberger et al.
U.S. Appl. No. 29/584,629, filed Nov. 16, 2016, Nurnberger et al.
U.S. Appl. No. 29/589,582, filed Jan. 3, 2017, Nurnberger et al.
U.S. Appl. No. 29/589,583, filed Jan. 3, 2017, Nurnberger et al.
U.S. Appl. No. 29/589,586, filed Jan. 3, 2017, Nurnberger et al.
U.S. Appl. No. 29/589,621, filed Jan. 3, 2017, Nurnberger et al.
U.S. Appl. No. 29/595,005, filed Feb. 24, 2017, Nurnberger et al.
U.S. Appl. No. 29/604,102, filed May 15, 2017, Nurnberger et al.
U.S. Appl. No. 29/616,003, filed Sep. 1, 2017, Re et al.
U.S. Appl. No. 29/616,006, filed Sep. 1, 2017, Re et al.
U.S. Appl. No. 29/616,008, filed Sep. 1, 2017, Re et al.
U.S. Appl. No. 29/616,010, filed Sep. 1, 2017, Re et al.
U.S. Appl. No. 29/616,014, filed Sep. 1, 2017, Re et al.
U.S. Appl. No. 29/621,813, filed Oct. 11, 2017, Nurnberger et al.
U.S. Appl. No. 29/621,815, filed Oct. 11, 2017, Nurnberger et al.
U.S. Appl. No. 29/626,411, filed Nov. 16, 2017, Nurnberger et al.
U.S. Appl. No. 29/626,415, filed Nov. 16, 2017, Nurnberger et al.
U.S. Appl. No. 29/626,419, filed Nov. 16, 2017, Hill et al.
U.S. Appl. No. 29/626,801, filed Nov. 20, 2017, Hill et al.
U.S. Appl. No. 29/631,883, filed Jan. 3, 2018, Hill et al.
U.S. Appl. No. 29/631,887, filed Jan. 3, 2018, Hill et al.

* cited by examiner

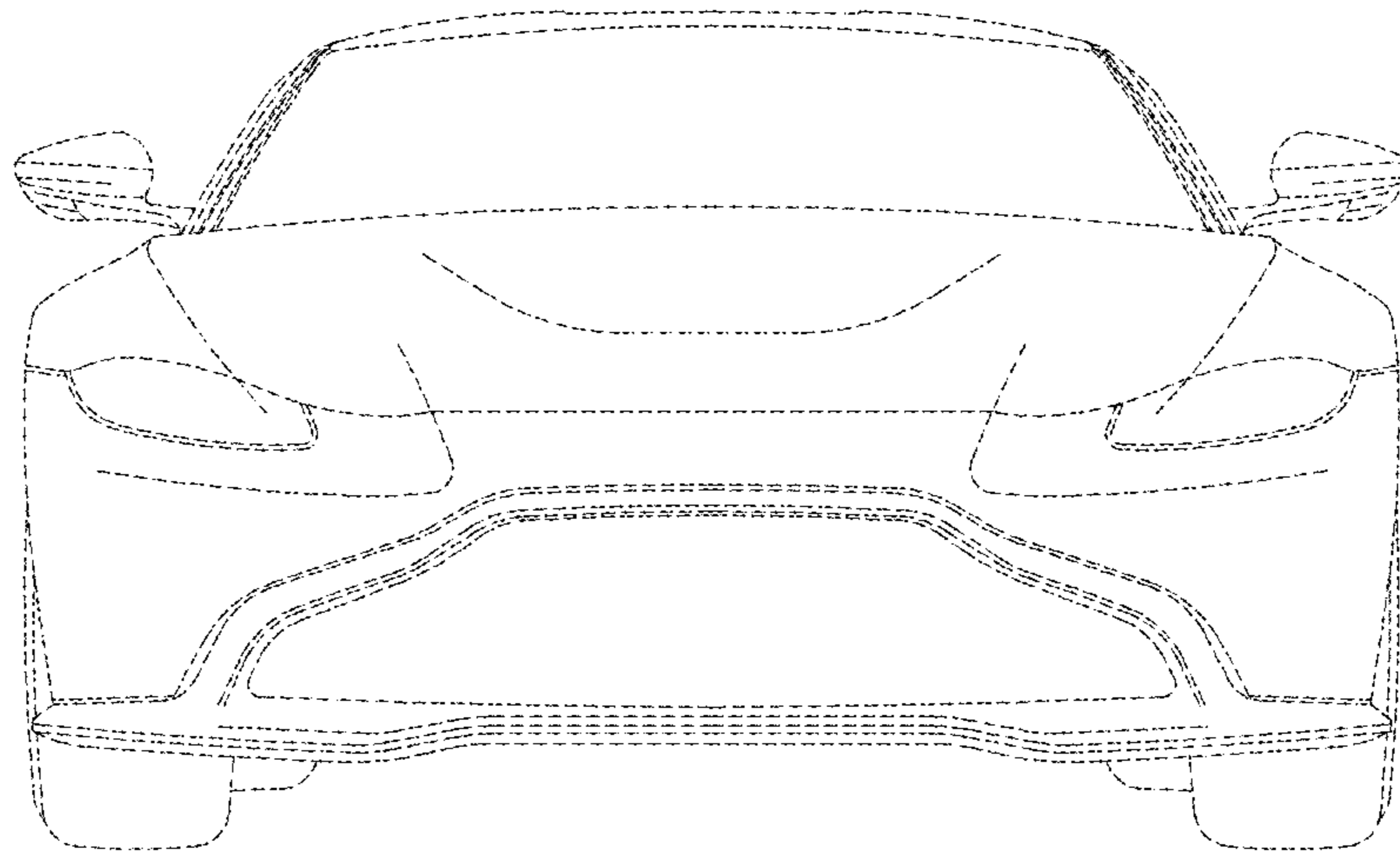

Fig. 1

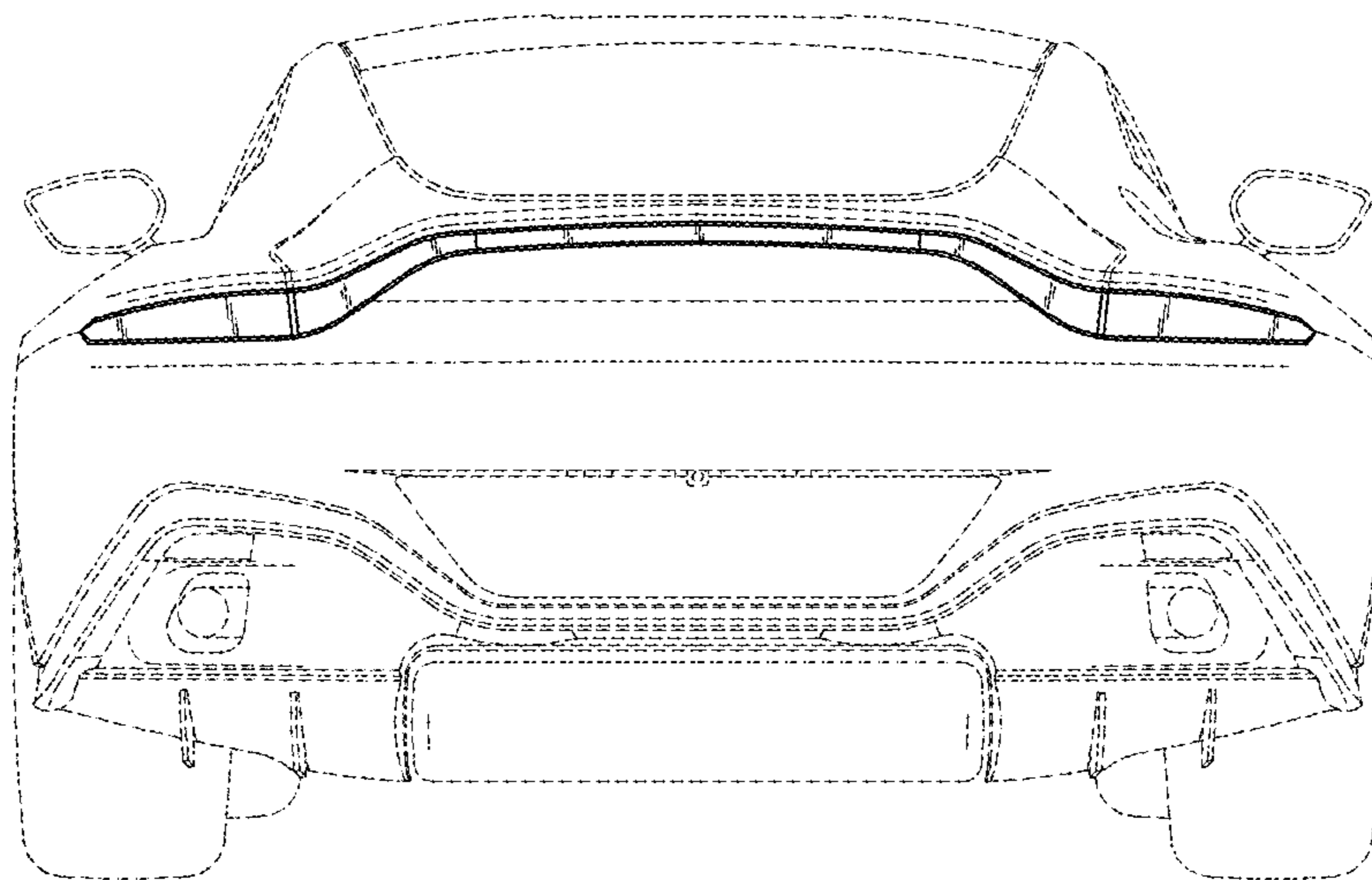

Fig. 2

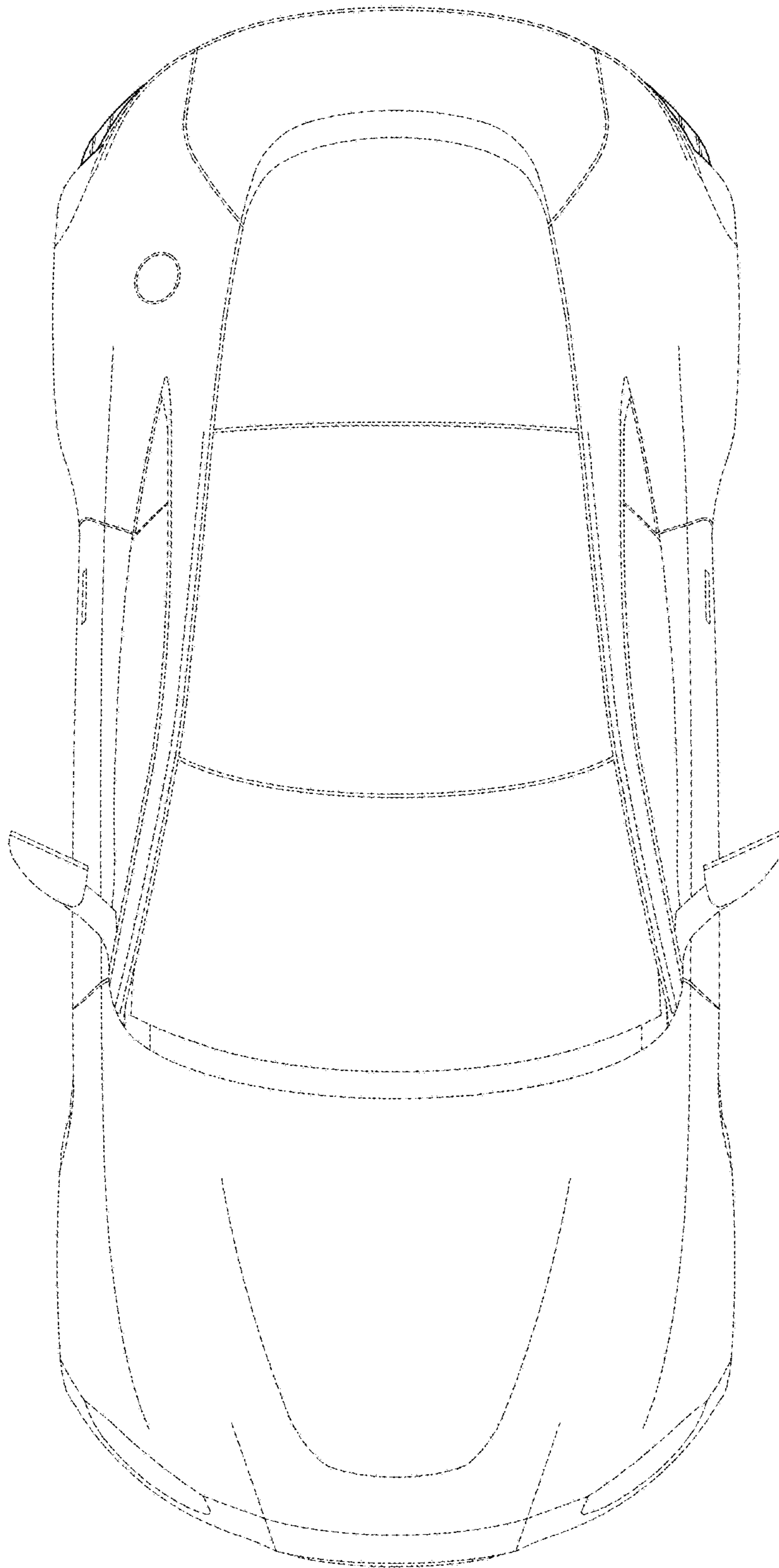

Fig. 3

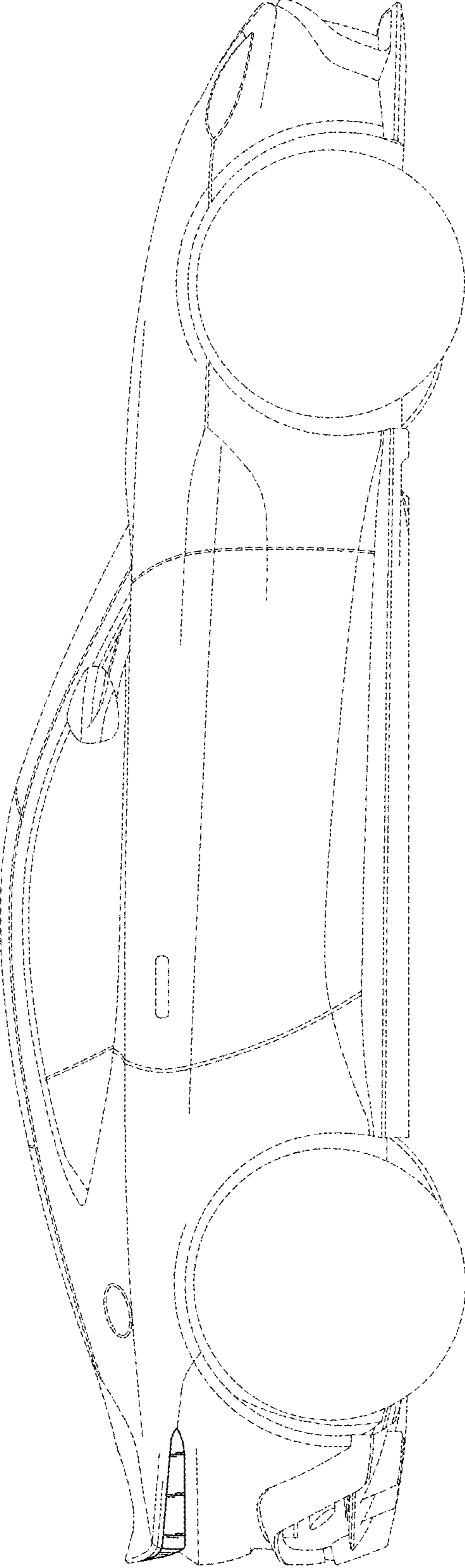

Fig. 4

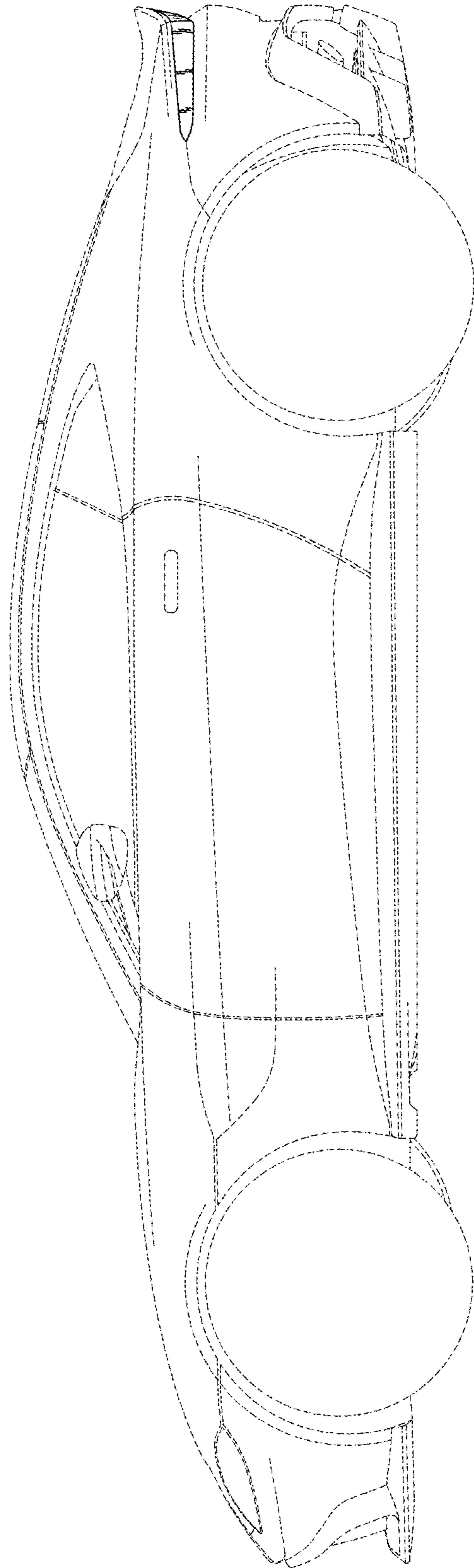

Fig. 5

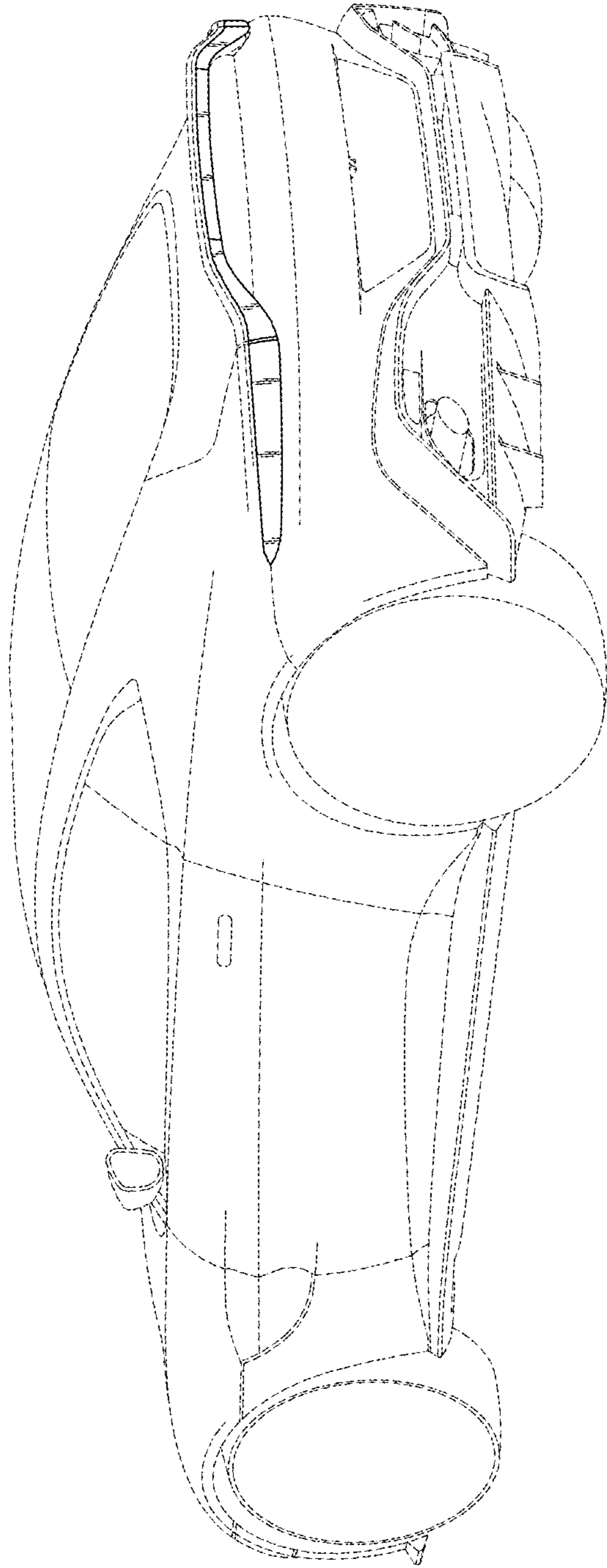

Fig. 6

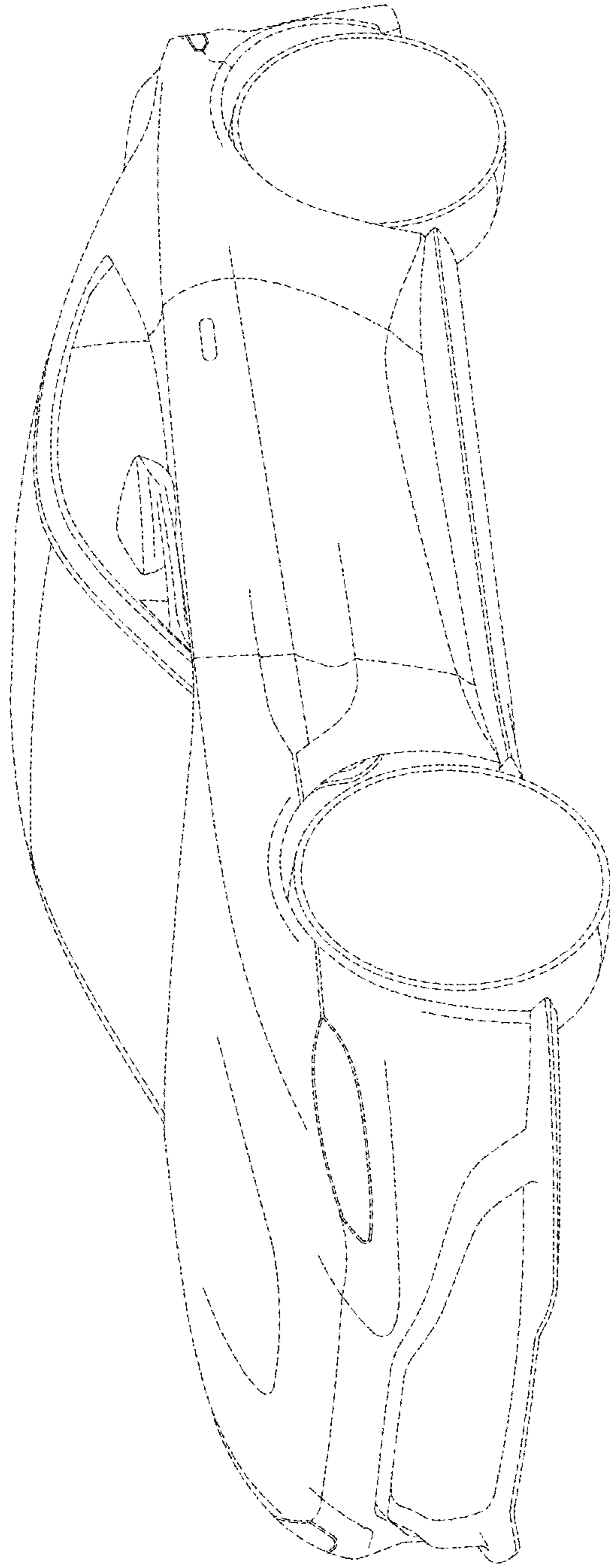

Fig. 7

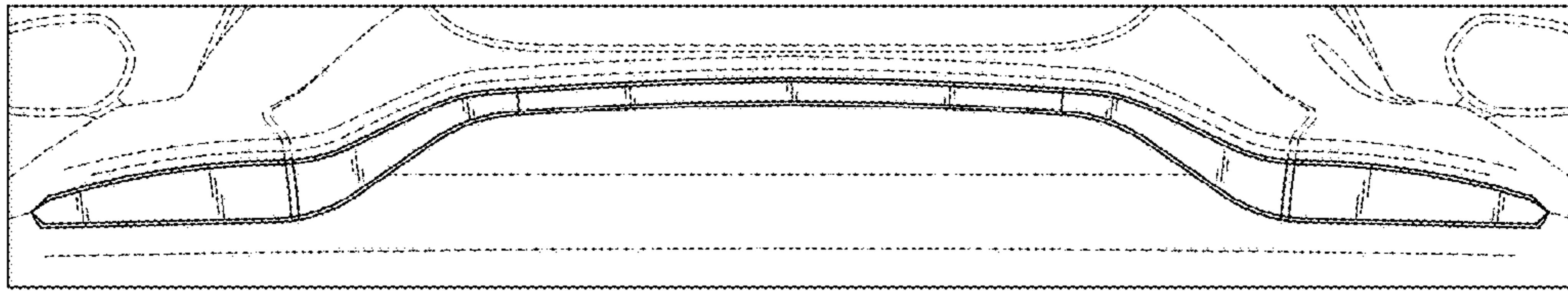

Fig. 8

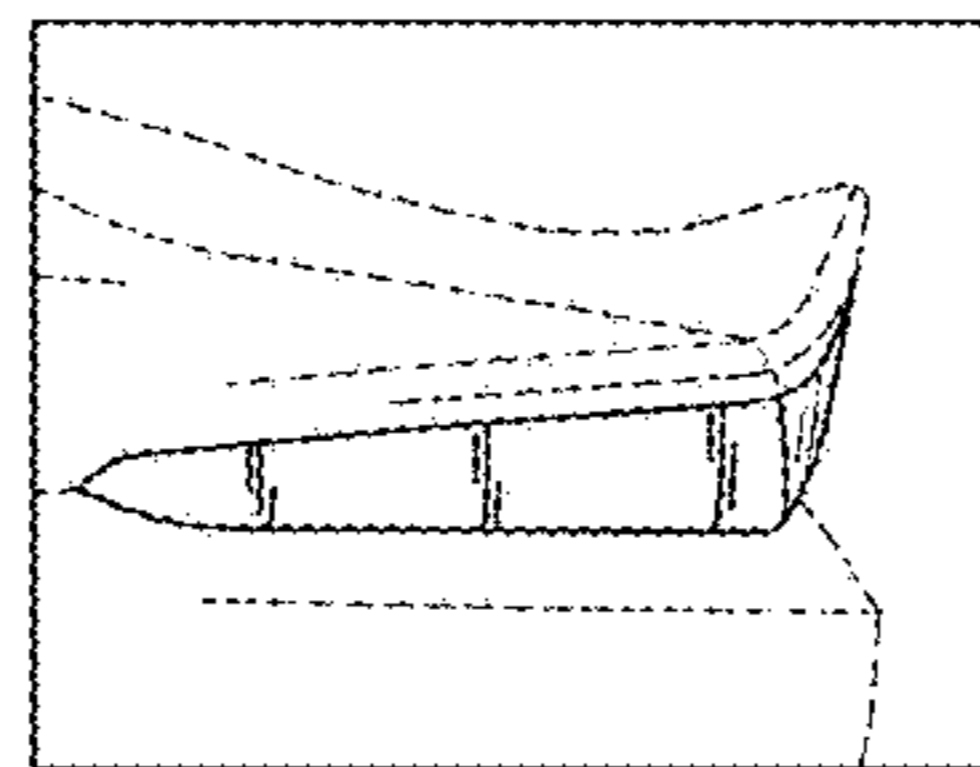

Fig. 9

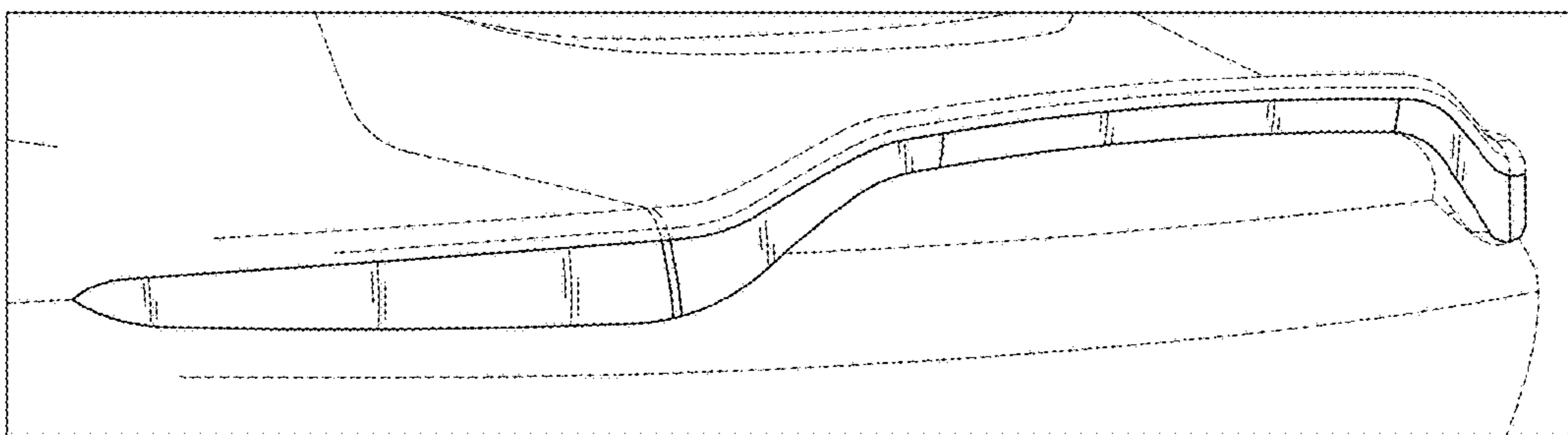

Fig. 10