



US00D837982S

(12) **United States Design Patent** (10) **Patent No.:** **US D837,982 S**
Adler (45) **Date of Patent:** **** Jan. 8, 2019**

(54) **SUTURE GRASPER TIP**
(71) Applicant: **Flexbar Machine Corporation**,
Islandia, NY (US)
(72) Inventor: **Daniel Adler**, Islandia, NY (US)
(73) Assignee: **Flexbar Machine Corp.**, Islandia, NY
(US)

D722,379 S 2/2015 Thouement
D749,731 S 2/2016 Wegener
D790,699 S * 6/2017 Dexter D24/146
9,782,215 B2 * 10/2017 Haberstich A61B 17/00234
D804,028 S * 11/2017 Linnenschmidt D24/145
D828,555 S * 9/2018 Anderson D24/145
D828,556 S * 9/2018 Anderson D24/145

(Continued)

(**) Term: **15 Years**
(21) Appl. No.: **29/599,640**
(22) Filed: **Apr. 5, 2017**
(51) **LOC (11) Cl.** **24-02**
(52) **U.S. Cl.**
USPC **D24/145**
(58) **Field of Classification Search**
USPC D24/127, 133, 143, 144, 145, 146, 147;
606/1, 40, 41, 45, 51, 139, 144, 167, 174,
606/213, 219, 221; 227/19, 175.1, 175.2,
227/176.1, 180.1; D8/5, 19, 20, 92, 99
CPC A61B 17/32; A61B 17/064; A61B 17/068;
A61B 17/076; A61B 17/3201; A61B
17/0469; A61B 17/0482; A61B 17/0625;
A61B 17/06166; A61B 17/00349; A61B
17/06066; A61B 2017/2945; A61B
2017/29291; A61B 2017/06176; A61B
2017/320072; A61B 2017/00424; A61B
2017/2825
See application file for complete search history.

OTHER PUBLICATIONS

Search Report issued in Taiwan Application: 106305902 dated Jun. 4, 2018, pp. 1.

Primary Examiner — Wan Laymon
Assistant Examiner — Clint A Samuel
(74) *Attorney, Agent, or Firm* — Tutunjian & Bitetto, P.C.

(57) **CLAIM**

The ornamental design for a suture grasper tip, as shown and described.

DESCRIPTION

FIG. 1 is a perspective view of the suture grasper tip showing my new design;
FIG. 2 is a Right side view thereof, the Left side being a mirror image of the Right side;
FIG. 3 is a top view thereof;
FIG. 4 is a bottom view thereof;
FIG. 5 is a front view thereof;
FIG. 6 is a perspective view of the suture grasper tip in an extended position;
FIG. 7 is a Right side view thereof, the Left side being a mirror image of the Right side;
FIG. 8 is a top view thereof;
FIG. 9 is a bottom view thereof; and,
FIG. 10 is a front view thereof.

The broken lines showing in the drawings are for the purpose of illustrating environmental structure and form no part of the claimed design.

1 Claim, 3 Drawing Sheets

(56) **References Cited**
U.S. PATENT DOCUMENTS
4,869,259 A * 9/1989 Elkins A61B 8/0833
600/458
D624,653 S 9/2010 Boillat
D625,812 S 10/2010 Dapri et al.
D625,813 S 10/2010 Dapri et al.
D625,815 S 10/2010 Griffis, III et al.
8,834,497 B2 * 9/2014 Snell A61B 17/0467
606/148

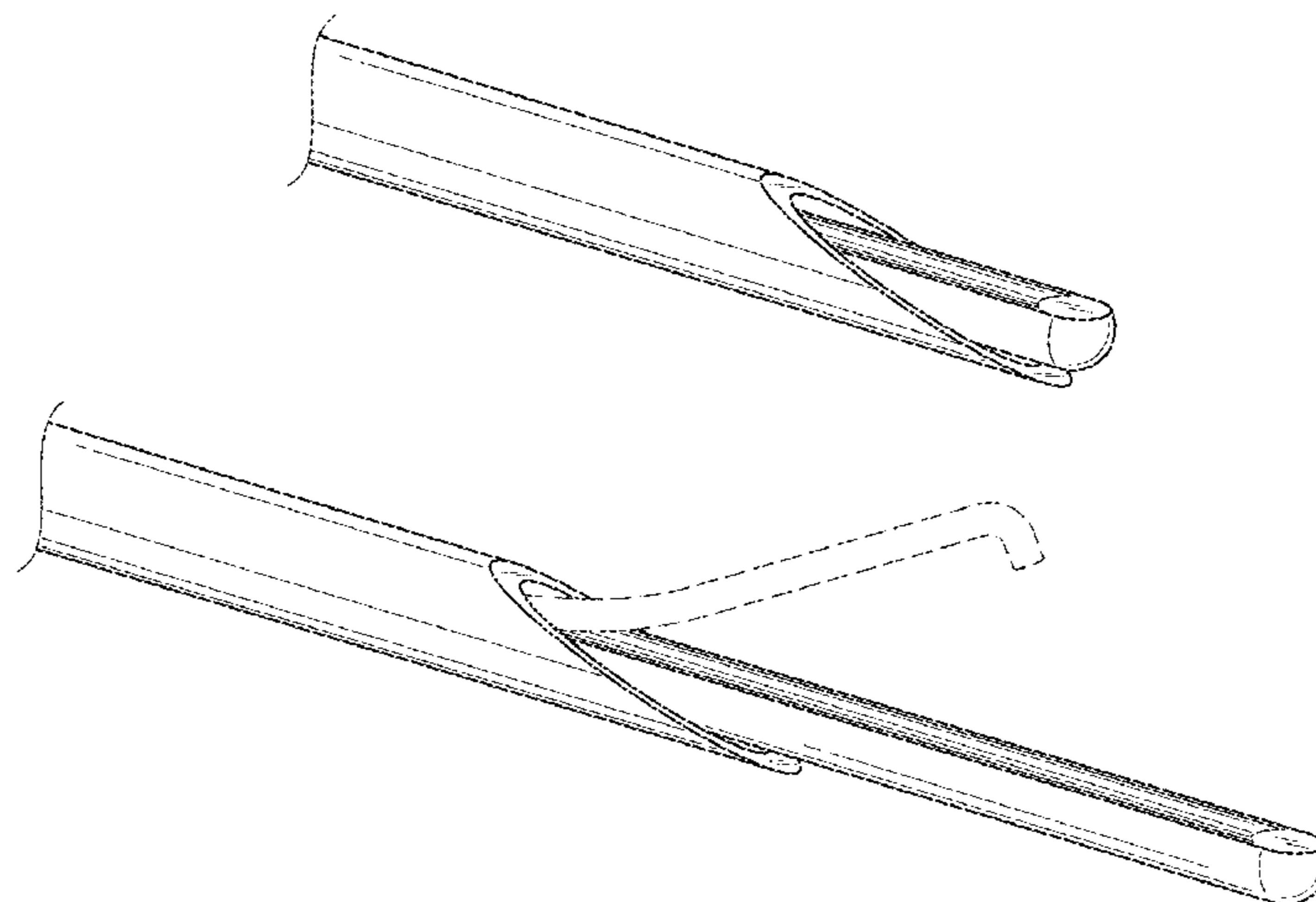

(56)

References Cited

U.S. PATENT DOCUMENTS

2006/0030848 A1* 2/2006 Craig A61B 17/32009
606/49
2012/0095479 A1* 4/2012 Bowe A61B 17/50
606/129
2012/0253376 A1* 10/2012 Liu A61B 17/3421
606/185
2013/0053870 A1* 2/2013 Evans A61B 17/0467
606/144
2017/0252038 A1* 9/2017 Callaghan A61B 17/06066
2018/0116652 A1* 5/2018 Torrie A61B 17/06109

* cited by examiner

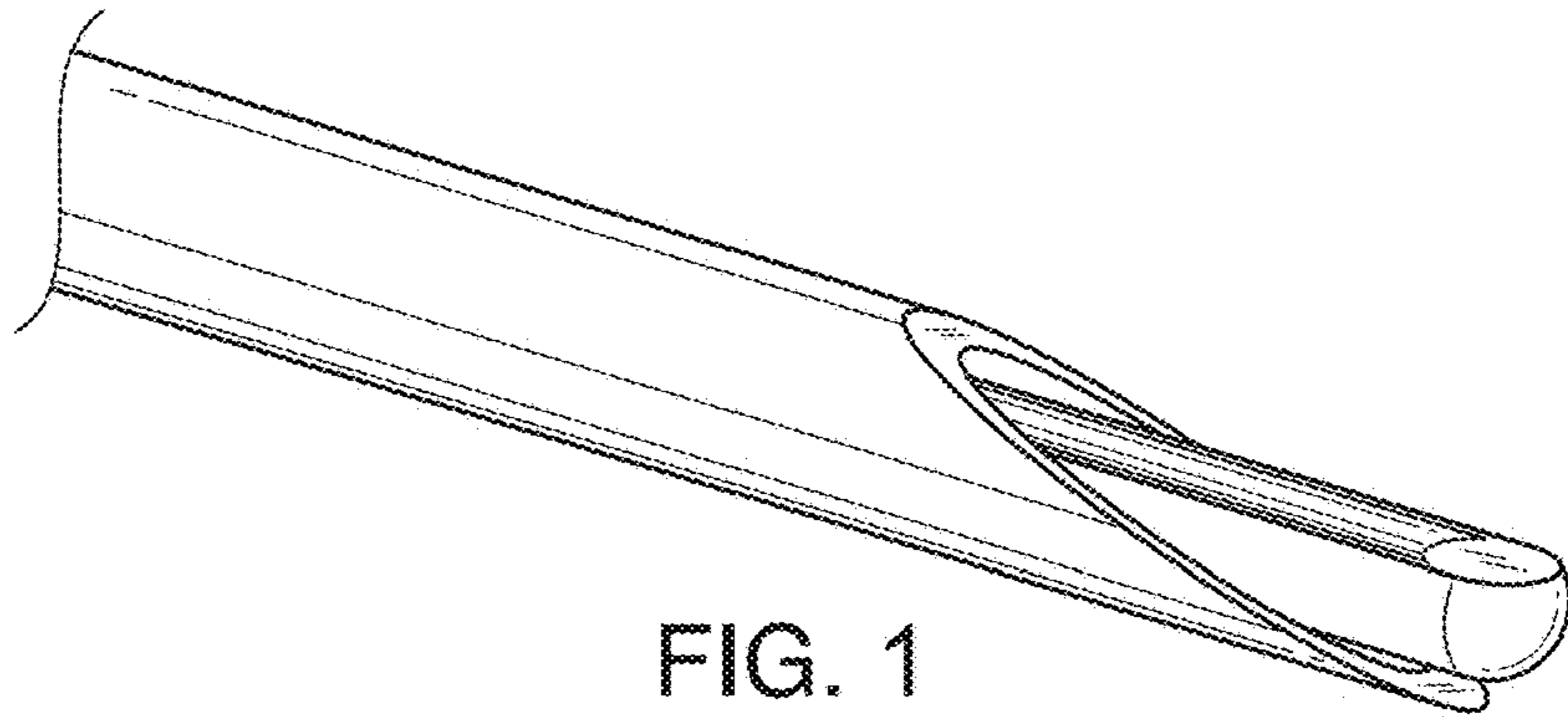

FIG. 1

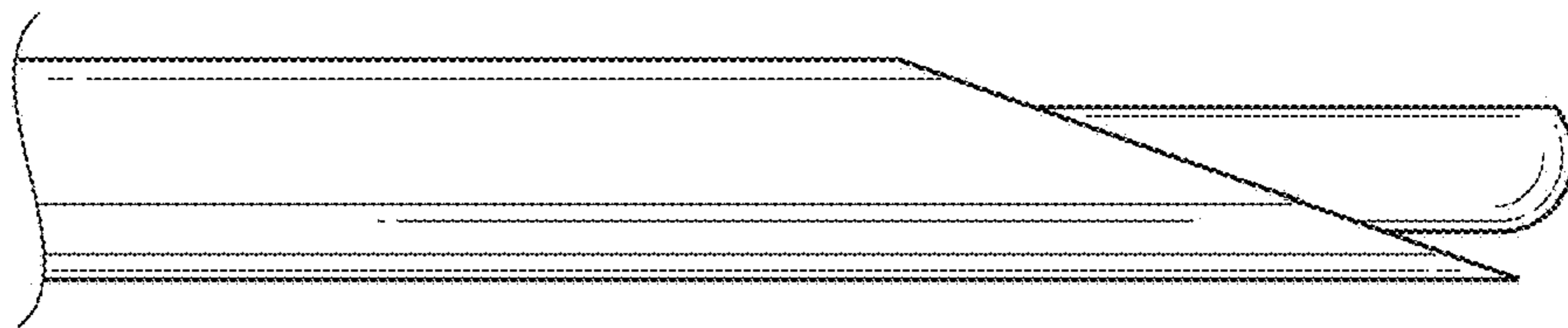

FIG. 2

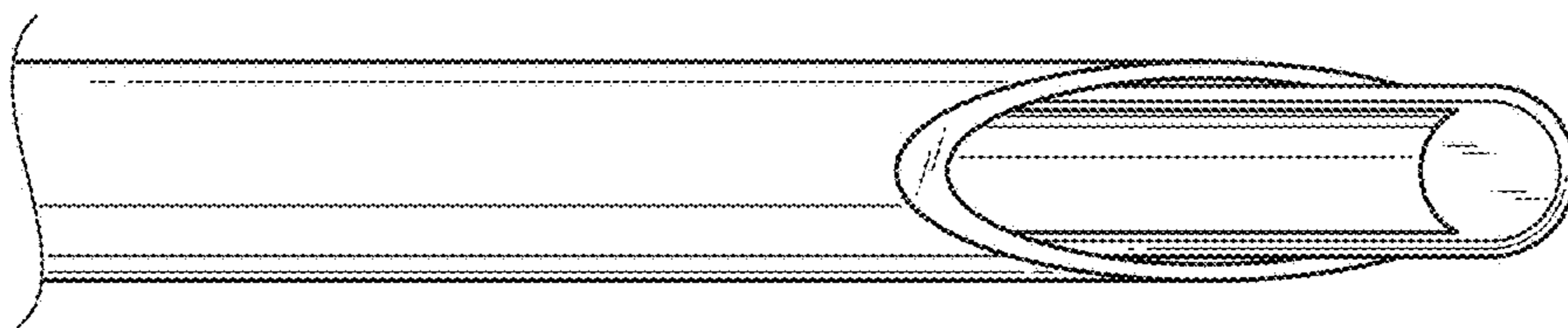

FIG. 3

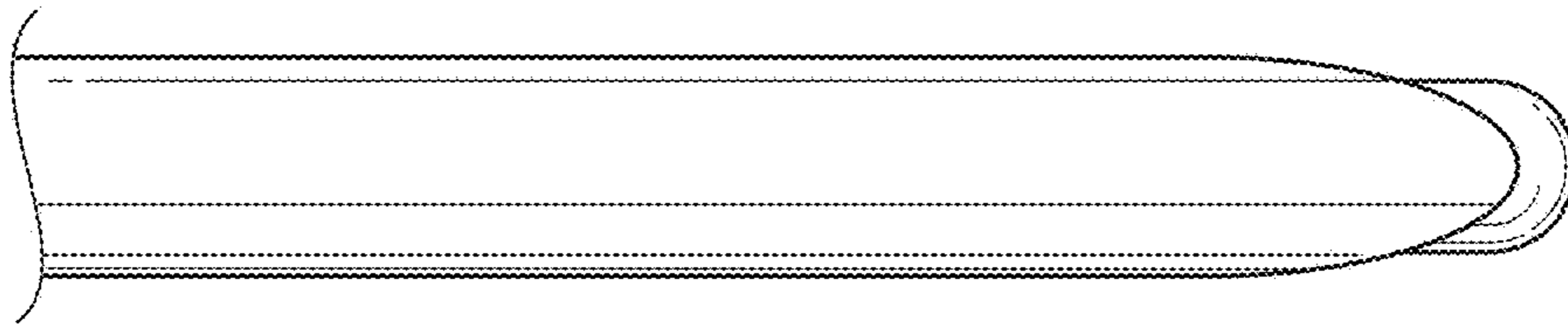

FIG. 4

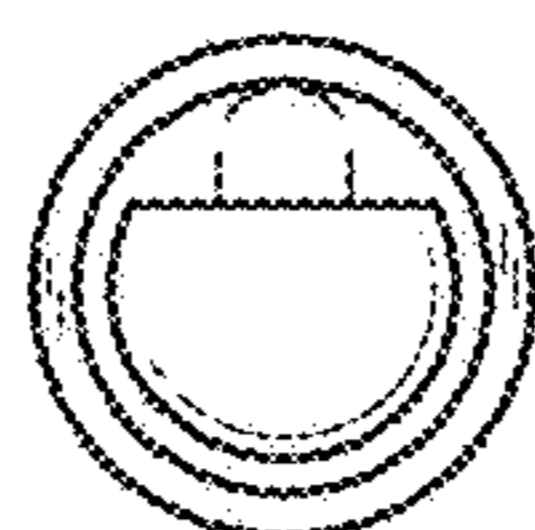
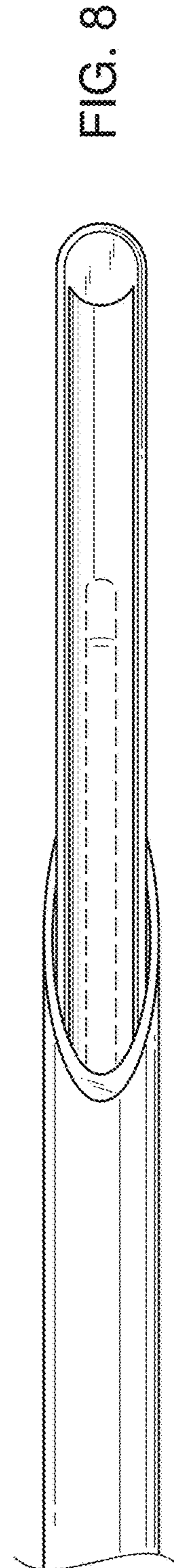
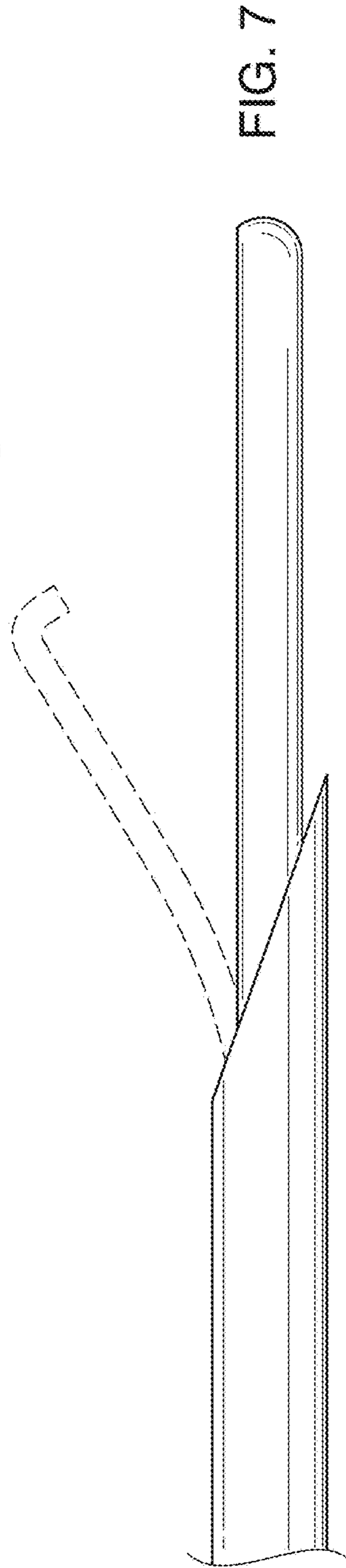
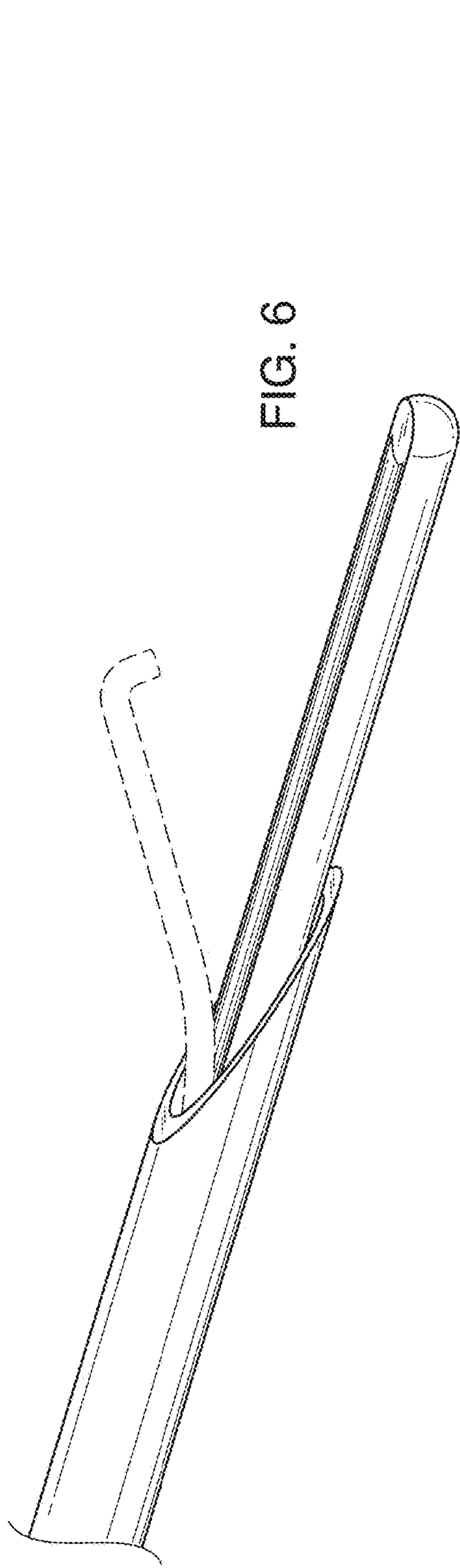

FIG. 5



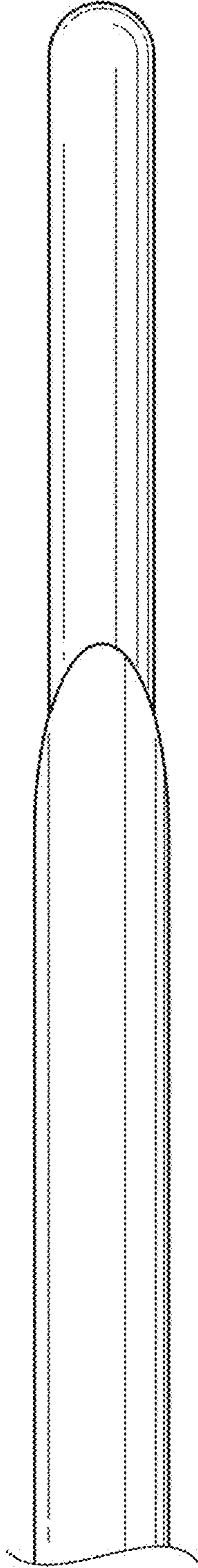

FIG. 9

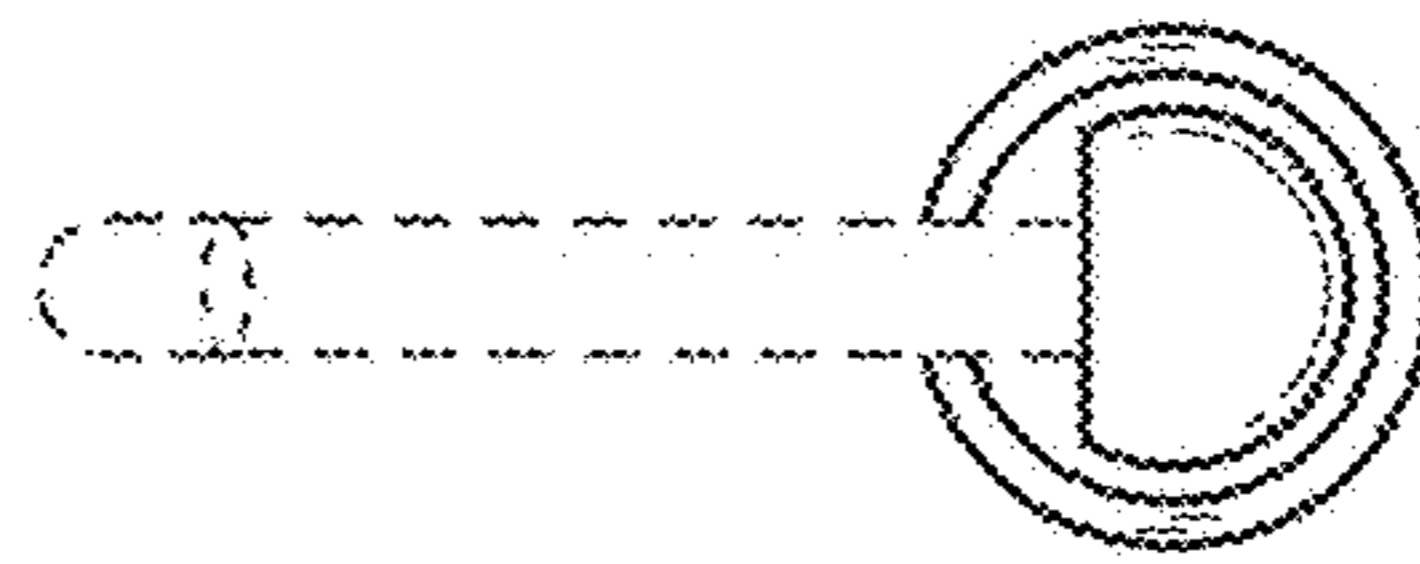

FIG. 10