



US00D837511S

(12) **United States Design Patent** (10) **Patent No.:** **US D837,511 S**  
**Maier** (45) **Date of Patent:** **\*\* Jan. 8, 2019**

(54) **HANDBAG**

(71) Applicant: **BOTTEGA VENETA SA**, Cadempino (CH)

(72) Inventor: **Thomas Rudolf Maier**, Palm Beach, FL (US)

(73) Assignee: **BOTTEGA VENETA SA**, Cadempino (CH)

(\*\*) Term: **15 Years**

(21) Appl. No.: **29/625,964**

(22) Filed: **Nov. 14, 2017**

(30) **Foreign Application Priority Data**

May 17, 2017 (WO) ..... DM/096357

(51) **LOC (11) Cl.** ..... **03-01**

(52) **U.S. Cl.**  
USPC ..... **D3/243**

(58) **Field of Classification Search**  
USPC ..... D3/232-233, 240-243, 245-246  
CPC ..... A45C 1/024; A45C 3/06  
See application file for complete search history.

(56) **References Cited**

U.S. PATENT DOCUMENTS

D789,079 S \* 6/2017 Michele ..... D3/232  
D789,684 S \* 6/2017 Michele ..... D3/232  
D793,723 S \* 8/2017 Lopez Montoya ..... D3/232  
D798,046 S \* 9/2017 Michele ..... D3/232

\* cited by examiner

*Primary Examiner* — Holly H Baynham

(74) *Attorney, Agent, or Firm* — Lucas & Mercanti, LLP

(57) **CLAIM**

The ornamental design for a handbag, as shown and described.

**DESCRIPTION**

FIG. 1 is a perspective view of the handbag according to the design;

FIG. 2 is a front view thereof;

FIG. 3 is a back view thereof;

FIG. 4 is a left side view thereof;

FIG. 5 is a right side view thereof;

FIG. 6 is a top view thereof; and,

FIG. 7 is a bottom view thereof.

The broken lines showing a handbag strap are for the purposes of illustrating environment and form no part of the claimed design.

**1 Claim, 7 Drawing Sheets**

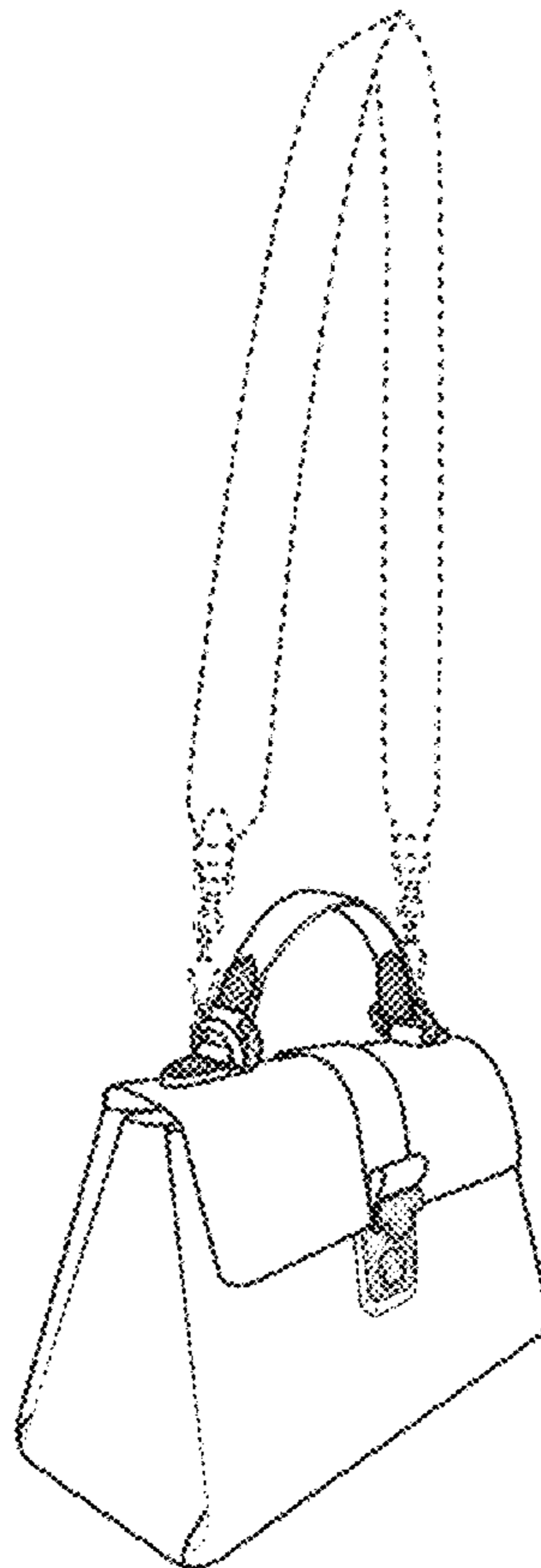

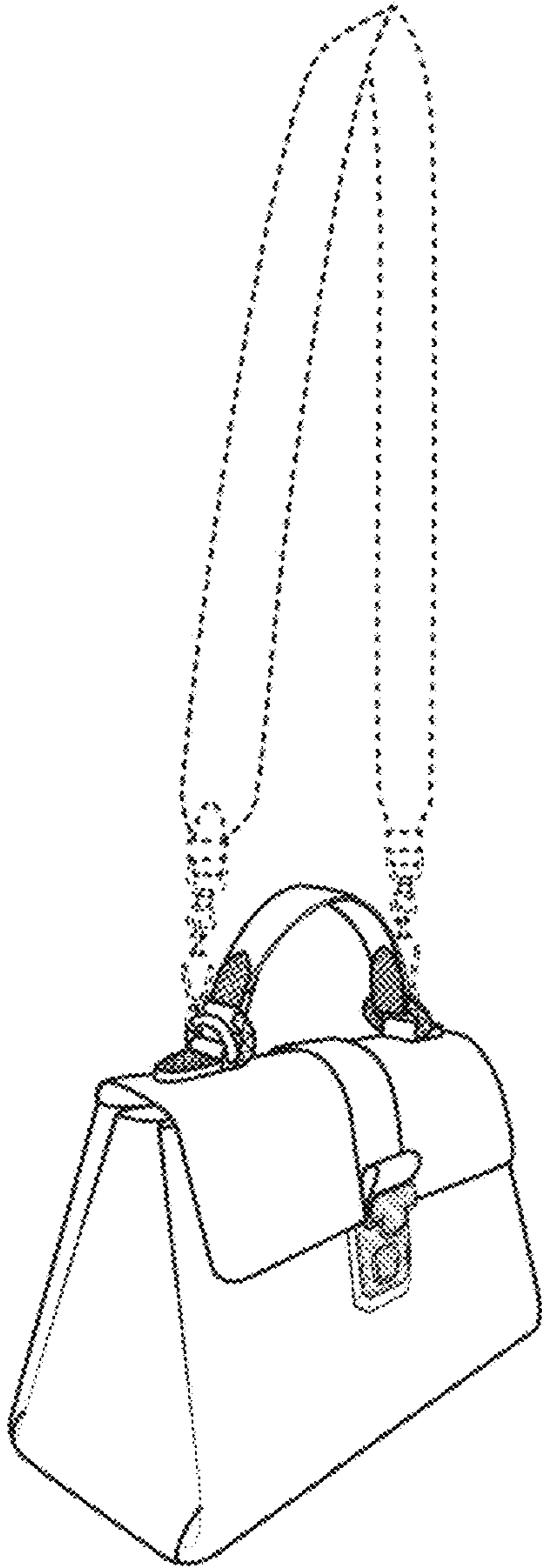

FIG. 1



FIG.2



FIG.3

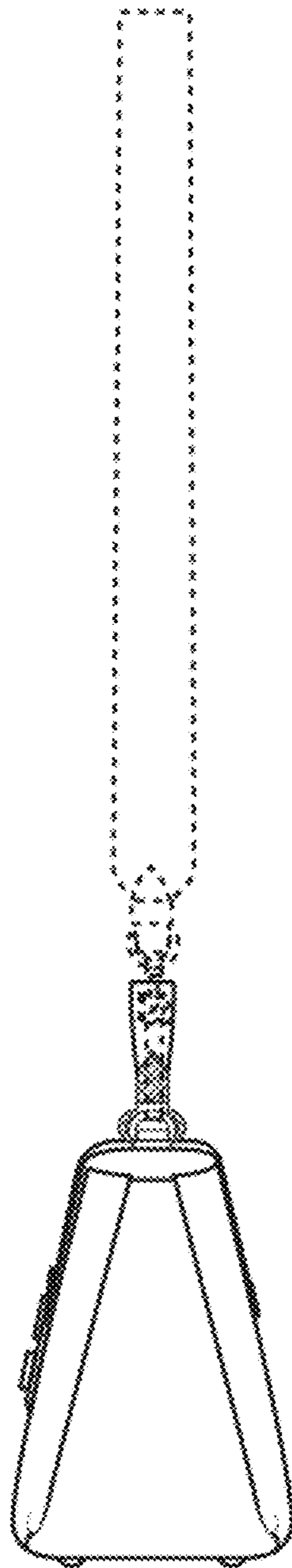

FIG.4

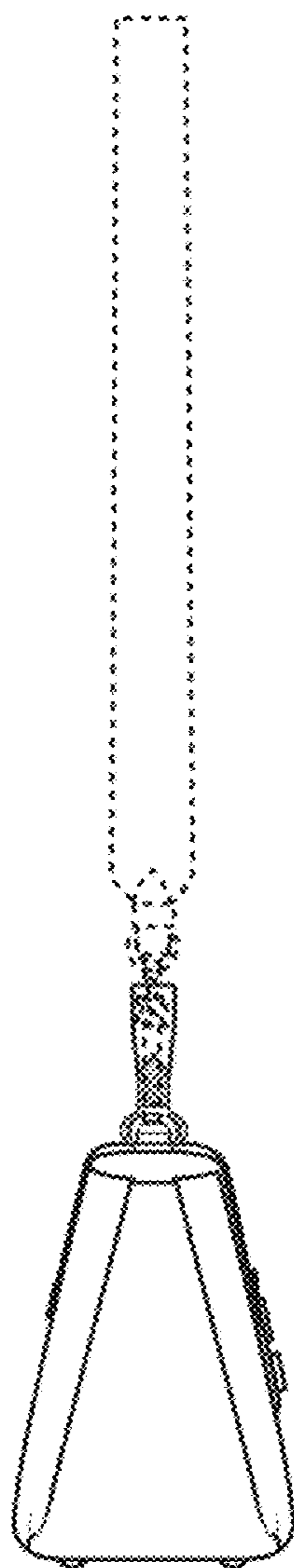

FIG.5

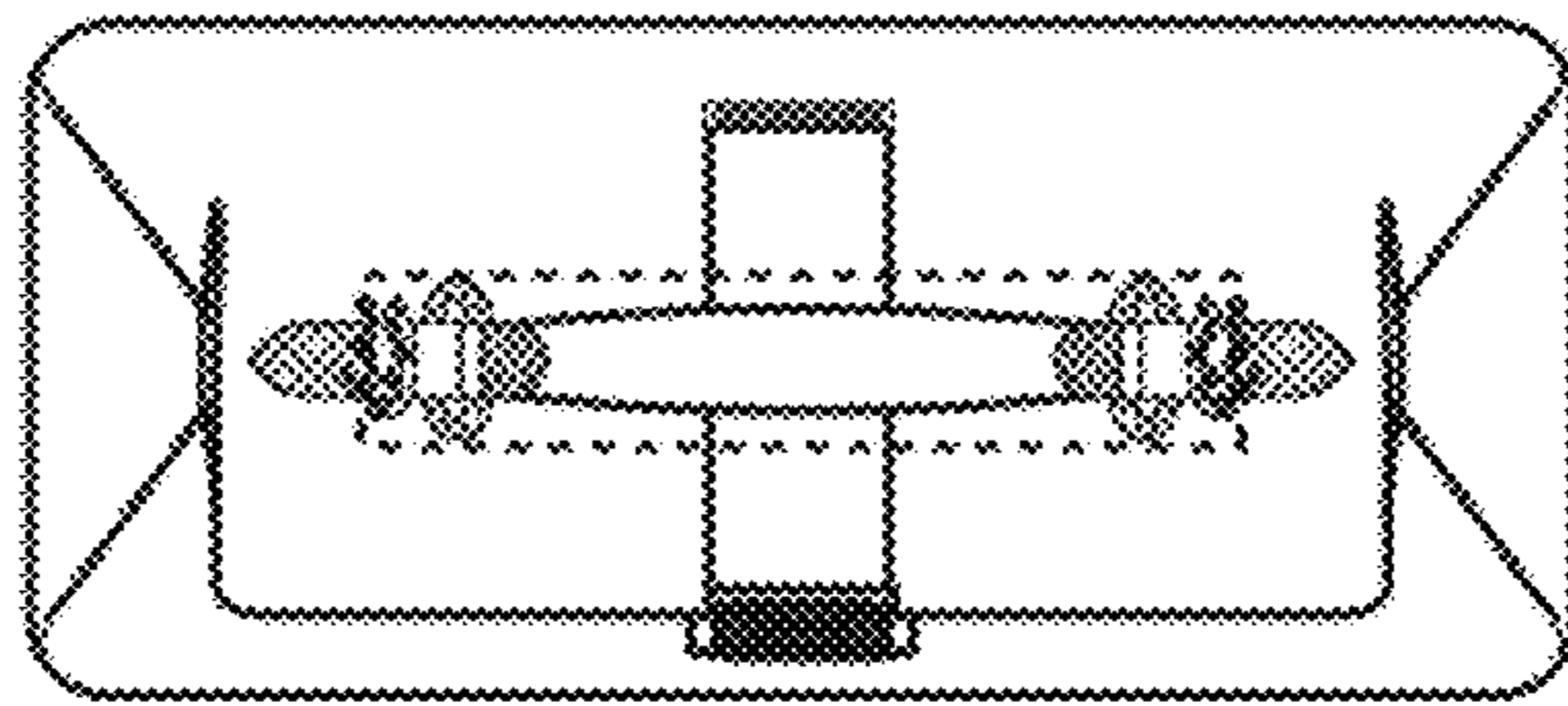

FIG.6

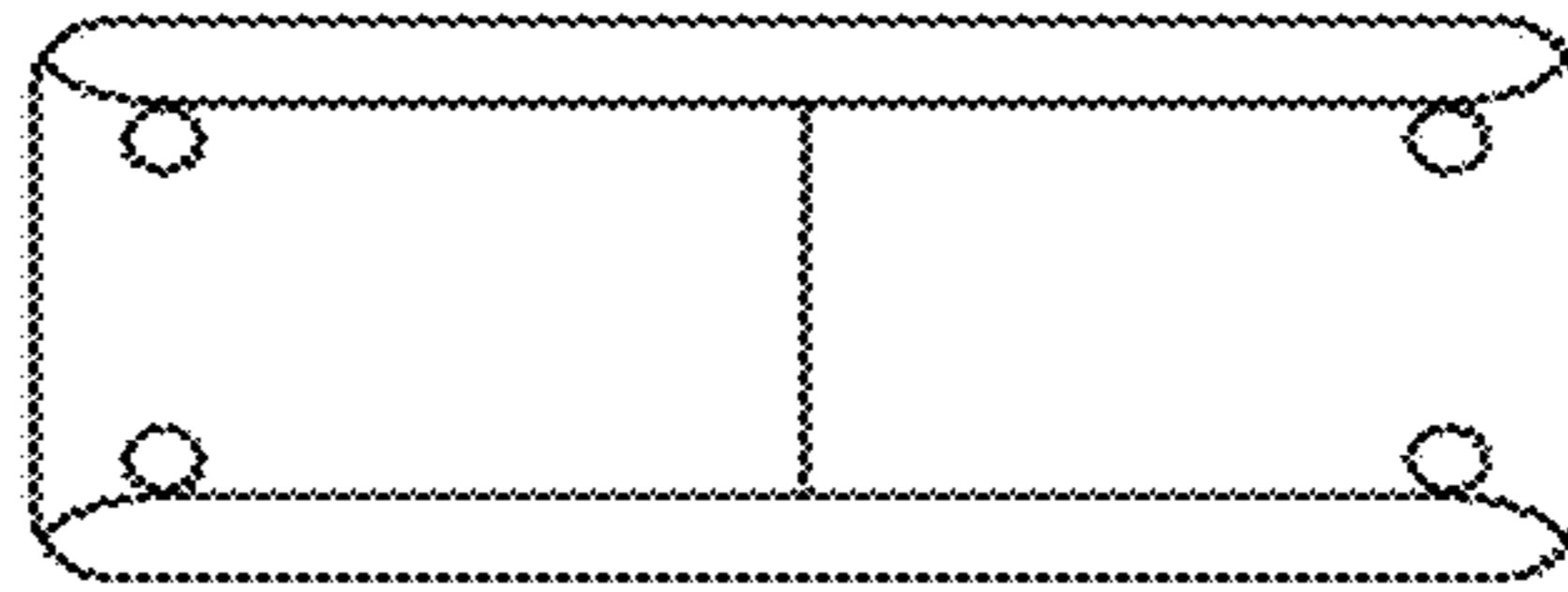

FIG.7