

US00D837464S

(12) **United States Design Patent**
Park

(10) **Patent No.:** **US D837,464 S**

(45) **Date of Patent:** **** Jan. 1, 2019**

(54) **PET GROOMING TOOL**

(71) Applicant: **Jonathan Yejun Park**, San Francisco, CA (US)

(72) Inventor: **Jonathan Yejun Park**, San Francisco, CA (US)

(73) Assignee: **EVERYMARKET INC.**, New York City, NY (US)

(**) Term: **15 Years**

(21) Appl. No.: **29/610,141**

(22) Filed: **Jul. 10, 2017**

(51) **LOC (11) Cl.** **30-99**

(52) **U.S. Cl.**
USPC **D30/159**; D30/158

(58) **Field of Classification Search**
USPC D30/158, 159, 199, 162, 106; 119/625, 119/633, 600, 617, 628, 632, 631, 613, 119/618, 619, 620, 611; 132/126, 142, 132/143, 155; 30/114, 130, 301, 305, 30/315, 316, 299, 303, 306, 169, 322, 31, 30/30, 279.2, 280, 287, 294, 199, 30/329-344, 346.56, 346.61, 355, 357, 30/172; D7/672-676, 687, 686, 634, 619, D7/688, 653; 425/298; 426/503; D4/136, 127, 124-126, 116-118, 199, D4/194, 137; D32/42, 25, 41, 48, 40, 35, D32/46; D23/261; 2/160; 172/379, 380; D6/415, 410, 411; 294/1.3, 1.5, 55, 99.1, 294/49, 7, 9, 99.2, 118, 119, 19.2, 52; 209/418; D24/211, 147; D21/532, 398; D19/36; 34/381, 103, 104, 107; D11/104, 86; 56/400.01, 400.1, 400.17, 56/400.21, 400.05, 400.04, 330; 403/329, 403/326, 361; 15/402, 142, 236.07, 15/236.08, 236.05, 250.48, 256.5, 245.1, 15/143.1, 145, 176.1, 176.4, 236.01, 245; 601/137, 136, 80, 93, 95, 97, 101, 103,

601/138, 143-147; D28/91.2, 63, 52, 48, D28/31; D8/13, 6, 10, 11, 12, 1, 45; 126/173, 214 C, 25 R; 99/450; 156/579; 7/167; 16/422

CPC A01K 13/00; A01K 13/002; B26B 19/24; B26B 19/063; B26B 21/16; B26B 21/18; B26B 21/521; B26B 21/4075; B26B 21/522; A45D 24/30; A45D 24/00; A45D 24/04; A45D 24/10; A45D 24/36; A45D 24/02; A46B 5/02; A46B 5/021; A46B 5/026; A46B 5/028; A46B 2200/1093; (Continued)

(56) **References Cited**

U.S. PATENT DOCUMENTS

105,148 A * 7/1870 Warner et al. A45D 8/12 132/155
194,820 A * 9/1877 Holmes A01K 13/002 119/631

(Continued)

Primary Examiner — Susan Moon Lee

(74) *Attorney, Agent, or Firm* — Zheng Liu; Weintraub Tobin

(57) **CLAIM**

The ornamental design for a pet grooming tool, as shown and described.

DESCRIPTION

FIG. 1 is a top view of a pet grooming tool;
FIG. 2 is a bottom view of the pet grooming tool;
FIG. 3 is a side view of the pet grooming tool;
FIG. 4 is a front view of the pet grooming tool.
FIG. 5 is a back view of the pet grooming tool;
FIG. 6 is a first perspective view of the pet grooming tool;
and,
FIG. 7 is a second perspective view of the pet grooming tool.

1 Claim, 3 Drawing Sheets

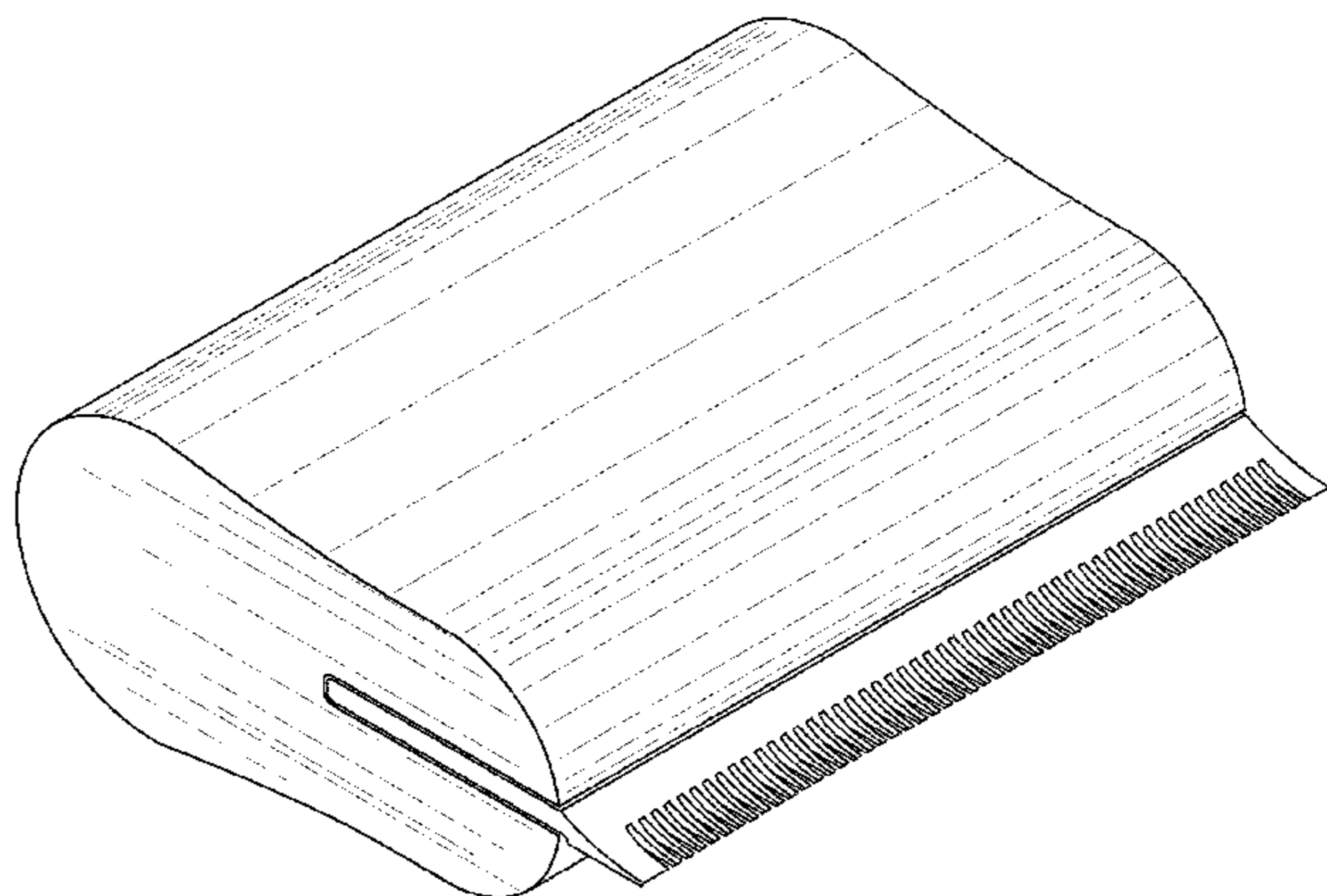
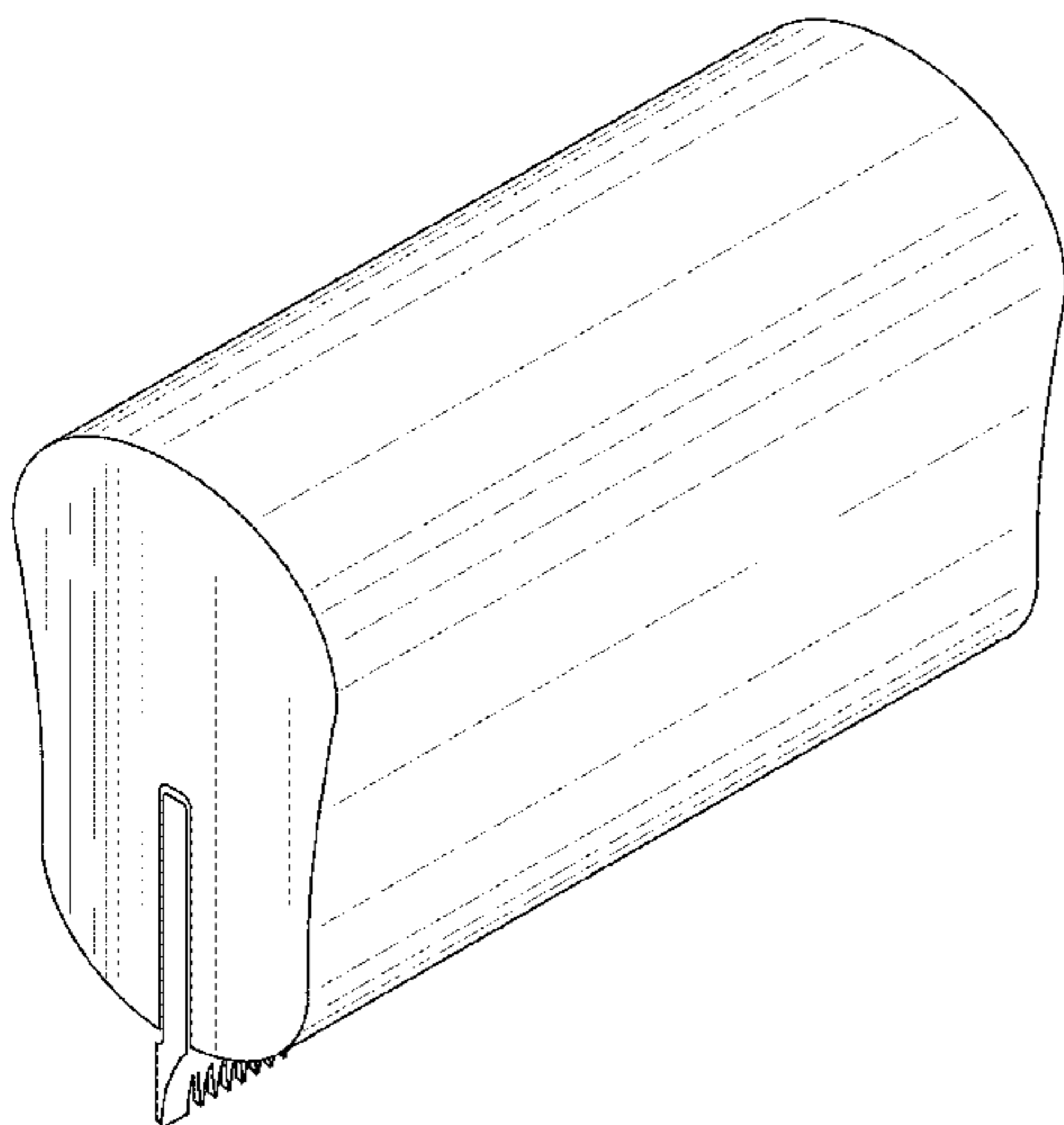

US D837,464 S

(58) **Field of Classification Search**
 CPC A46B 2200/10; B29C 63/0004; Y10T
 156/18; Y10T 16/476; B41F 15/44
 See application file for complete search history.

(56) **References Cited**

U.S. PATENT DOCUMENTS

309,668 A * 12/1884 Weightman A01K 13/002
 119/613
 335,894 A * 2/1886 Clark A01K 13/002
 119/631
 D19,979 S * 7/1890 Spruill D32/46
 431,490 A * 7/1890 Thomas A01K 13/002
 119/631
 D32,484 S * 4/1900 Bowles D32/46
 777,522 A * 12/1904 Links et al. A45D 40/0081
 15/105
 932,027 A * 8/1909 Kennedy A45D 24/02
 132/139
 946,370 A * 1/1910 Kelmel A46B 9/02
 15/160
 1,142,473 A * 6/1915 Worns A47L 13/08
 30/169
 D49,182 S * 6/1916 Gregwer D32/46
 D50,078 S * 12/1916 Schmitt D32/46
 1,381,478 A * 6/1921 Lawrence B23D 61/121
 407/117
 D64,611 S * 5/1924 Trachtenberg D28/25
 1,517,864 A * 12/1924 Runk A47L 13/16
 15/210.1
 1,520,045 A * 12/1924 Winiarski A47L 1/15
 15/245
 1,555,145 A * 9/1925 Naslin B44C 7/08
 15/245
 1,704,329 A * 3/1929 Klaus A47L 13/08
 15/236.07
 1,760,778 A * 5/1930 Ries A45D 24/08
 132/143
 1,820,768 A * 8/1931 Barker A45D 20/48
 132/142
 D100,790 S * 8/1936 Oishei 15/250.48
 D100,791 S * 8/1936 Oishei 15/250.48
 2,109,626 A * 3/1938 Sowers A47L 1/15
 15/105
 2,158,695 A * 5/1939 Foss B44C 7/08
 15/245
 D117,388 S * 10/1939 Woinarovicz D32/46
 2,287,231 A * 6/1942 Cathcard E04F 21/06
 15/236.08
 2,410,420 A * 11/1946 Bennett A47L 13/08
 15/231
 2,430,303 A * 11/1947 Ruhl A45D 24/24
 119/632
 2,501,987 A * 3/1950 Brown B26B 21/06
 132/289
 2,546,577 A * 3/1951 Young B27G 17/04
 15/236.08
 2,609,020 A * 9/1952 Becker A22B 5/205
 30/517
 D169,837 S * 6/1953 Blander D32/46
 D172,527 S * 6/1954 Wattles D32/41
 D173,462 S * 11/1954 Schmoller D32/41
 2,718,654 A * 9/1955 Draughn B27G 17/04
 15/236.06
 2,789,346 A * 4/1957 Algier B26B 21/06
 264/275
 2,824,330 A * 2/1958 Williams E04F 21/06
 15/145
 D182,580 S * 4/1958 Fredrickson 15/160
 3,007,503 A * 11/1961 Kuemmerling B23D 51/01
 30/517
 3,160,142 A * 12/1964 Torow A01K 13/002
 119/623

3,292,674 A * 12/1966 Turner B23D 61/121
 407/120
 3,302,233 A * 2/1967 Sebastiani E04F 21/04
 15/235.4
 D214,977 S * 8/1969 Roth D4/137
 3,488,764 A * 1/1970 Welsh B26B 21/06
 30/32
 3,676,888 A * 7/1972 Akers B44D 3/105
 15/144.1
 D233,586 S * 11/1974 Kopp D32/46
 3,864,778 A * 2/1975 Vopat B43L 21/00
 15/105
 3,893,424 A * 7/1975 Casler A01K 13/002
 119/618
 4,004,317 A * 1/1977 Beedle G11B 23/502
 125/39
 D243,382 S * 2/1977 Mox D32/46
 4,048,471 A * 9/1977 Ours B05C 17/10
 118/202
 4,064,588 A * 12/1977 Cooper B23D 49/11
 15/235.3
 4,097,951 A * 7/1978 Hurtt B05C 17/10
 15/144.1
 4,198,928 A * 4/1980 Borba A01K 13/002
 119/631
 D263,001 S * 2/1982 Wistrand D28/13
 RE31,433 E * 11/1983 Clark B23D 61/12
 502/215
 D275,723 S * 10/1984 Leininger D18/14
 D275,804 S * 10/1984 Saferstein D28/30
 4,612,707 A * 9/1986 Shea B26B 29/02
 30/162
 D289,335 S * 4/1987 Scofield D28/23
 4,727,788 A * 3/1988 Yoshida B23D 61/121
 83/848
 D303,479 S * 9/1989 Shumaker D7/696
 4,970,990 A * 11/1990 Wilhelmi A01K 13/002
 119/601
 D312,893 S * 12/1990 Hansen D28/48
 D313,881 S * 1/1991 Nielson D32/46
 4,984,326 A * 1/1991 Horie G03G 15/0812
 15/1.51
 4,989,511 A * 2/1991 Clarke, Jr. B41F 15/02
 101/123
 5,062,338 A * 11/1991 Baker B23D 61/121
 83/835
 5,072,746 A * 12/1991 Kantor A45D 24/30
 119/625
 D323,896 S * 2/1992 Alcazar D25/103
 5,101,530 A * 4/1992 Hansen A47L 13/11
 15/245
 D330,445 S * 10/1992 Hay D32/46
 D332,331 S * 1/1993 Hansen D32/41
 5,191,670 A * 3/1993 Lake A46B 15/00
 15/160
 5,321,868 A * 6/1994 Coulson B41F 15/02
 101/114
 5,353,817 A * 10/1994 Kantor A01K 13/002
 119/625
 D352,432 S * 11/1994 Monroe D32/41
 5,441,185 A * 8/1995 Dragos A45F 5/02
 15/236.01
 D369,886 S * 5/1996 McCollum D32/46
 5,524,316 A * 6/1996 Johnson B05C 17/10
 15/210.5
 5,632,289 A * 5/1997 Sharp A01K 13/002
 132/116
 5,666,732 A * 9/1997 Shea B26B 5/006
 30/169
 5,690,057 A * 11/1997 Curry A01K 13/002
 119/623
 D388,569 S * 12/1997 Israel D32/35
 5,809,608 A * 9/1998 Zadro B41F 15/44
 15/245
 5,865,945 A * 2/1999 McConaughy B29C 63/0004
 156/579

(56)

References Cited

U.S. PATENT DOCUMENTS

5,870,851 A * 2/1999 Shoemaker A01K 13/002
119/626
D410,177 S * 5/1999 Carder D7/693
5,987,687 A * 11/1999 Kilburn A46B 5/02
15/143.1
6,023,811 A * 2/2000 Ciarrocchi A47L 13/022
15/236.01
D422,124 S * 3/2000 Rimback D32/41
D428,315 S * 7/2000 Baker D8/14
6,082,307 A * 7/2000 Landreneau A01K 13/002
119/616
D454,254 S * 3/2002 Hellinger D4/138
D461,281 S * 8/2002 Lee D28/24
6,453,970 B1 * 9/2002 Stone B29C 63/0004
15/245
6,516,490 B1 * 2/2003 Hatala A47L 13/08
15/236.01
D472,346 S * 3/2003 Lee D28/24
6,604,768 B2 * 8/2003 Stevenson B28C 5/4203
15/236.07
D488,898 S * 4/2004 Ben-Moshe D32/41
6,733,056 B2 * 5/2004 Daniele A47F 13/08
294/180
6,796,000 B2 * 9/2004 Varner A47L 1/06
15/143.1
D507,682 S * 7/2005 Dunn D30/158
D508,299 S * 8/2005 Dunn D30/158
D520,994 S * 5/2006 Weiher D14/356
D524,983 S * 7/2006 Smith D28/31
D528,722 S * 9/2006 Hughes D32/46
D548,907 S * 8/2007 Killen D32/41
D557,333 S * 12/2007 Giannola D18/56
D582,103 S * 12/2008 Ragonetti D30/158
D582,408 S * 12/2008 Maiers D14/356
D586,512 S * 2/2009 van Deursen D32/46
D594,623 S * 6/2009 Felton D34/35
D607,042 S * 12/2009 Davidson D18/34.2
7,627,924 B2 * 12/2009 Vamer A47L 1/06
15/143.1
D609,917 S * 2/2010 Benson D32/35
7,757,336 B2 * 7/2010 Varner A47L 1/06
15/143.1
D624,262 S * 9/2010 Gringer D32/46
D625,064 S * 10/2010 Lee D32/41
7,806,033 B2 * 10/2010 Kocher B23D 61/121
83/835
D627,530 S * 11/2010 Benson D32/35
D670,432 S * 11/2012 Driver D28/21

D675,799 S * 2/2013 Beij D32/40
8,847,123 B2 * 9/2014 Shoshan A47J 37/04
219/520
8,967,157 B2 * 3/2015 Steiner A45D 24/10
132/150
9,182,075 B2 * 11/2015 Crosby F16B 47/003
9,199,321 B2 * 12/2015 Novak B23D 61/121
9,248,518 B2 * 2/2016 Elliston B23D 61/121
9,474,250 B1 * 10/2016 Tipton A01K 13/002
9,512,625 B2 * 12/2016 Taylor B28D 1/183
D781,693 S * 3/2017 Roan D8/394
9,839,198 B2 * 12/2017 Owen A01K 13/00
9,943,884 B2 * 4/2018 Viola A47L 25/08
D816,446 S * 5/2018 Schluter D8/45
D816,447 S * 5/2018 Schluter D8/45
D817,560 S * 5/2018 Tipton D30/159
2002/0073930 A1 * 6/2002 Kan A01K 13/002
119/631
2002/0100135 A1 * 8/2002 Machesky A47L 1/06
15/245
2004/0035282 A1 * 2/2004 Tsujimoto B23D 61/021
83/849
2005/0034263 A1 * 2/2005 Killen A47L 1/06
15/245
2005/0087084 A1 * 4/2005 Gray B41F 15/02
101/123
2006/0042035 A1 * 3/2006 Liu A47L 1/06
15/245
2006/0243293 A1 * 11/2006 Lanne A45D 24/30
132/163
2007/0209136 A1 * 9/2007 Eriksson B44D 3/164
15/236.01
2007/0251372 A1 * 11/2007 Petts B23D 61/021
83/846
2009/0173287 A1 * 7/2009 Wang A01K 13/002
119/625
2010/0300469 A1 * 12/2010 Bachrach A45D 24/02
132/107
2013/0180375 A1 * 7/2013 Rearick B23D 61/121
83/849
2013/0343041 A1 * 12/2013 Renforth A01K 13/002
362/109
2014/0144455 A1 * 5/2014 Heiberg A45D 24/02
132/159
2014/0230172 A1 * 8/2014 Resh E04H 4/1609
15/245
2015/0047576 A1 * 2/2015 Dauphin A01K 13/002
119/633
2016/0136695 A1 * 5/2016 Chalmers B08B 1/005
15/256.5

* cited by examiner

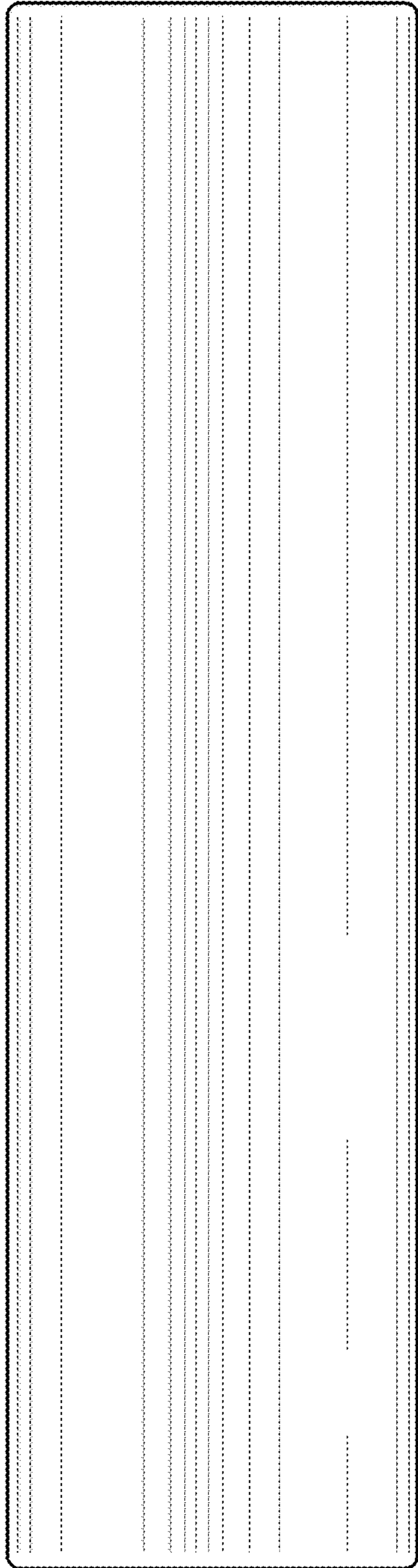

FIG. 1

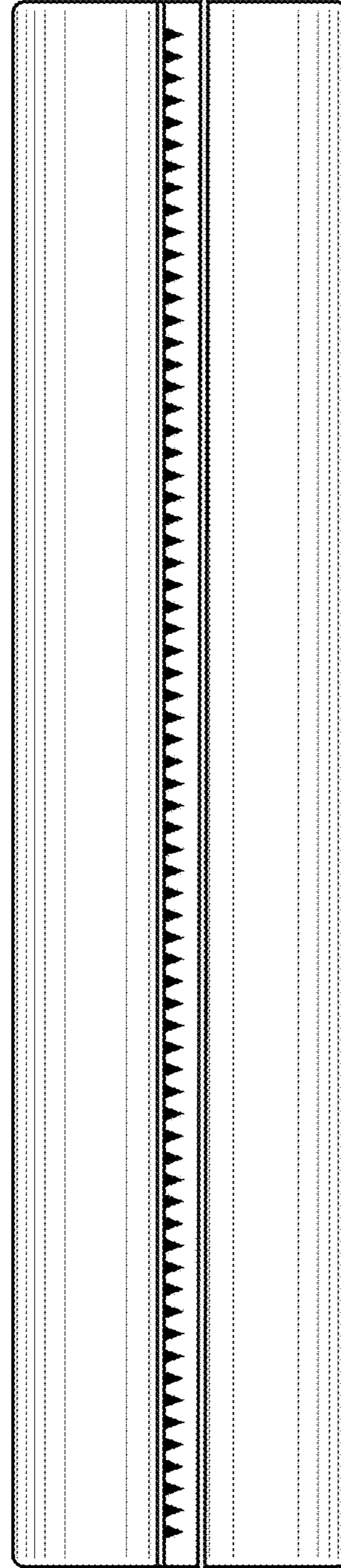

FIG. 2

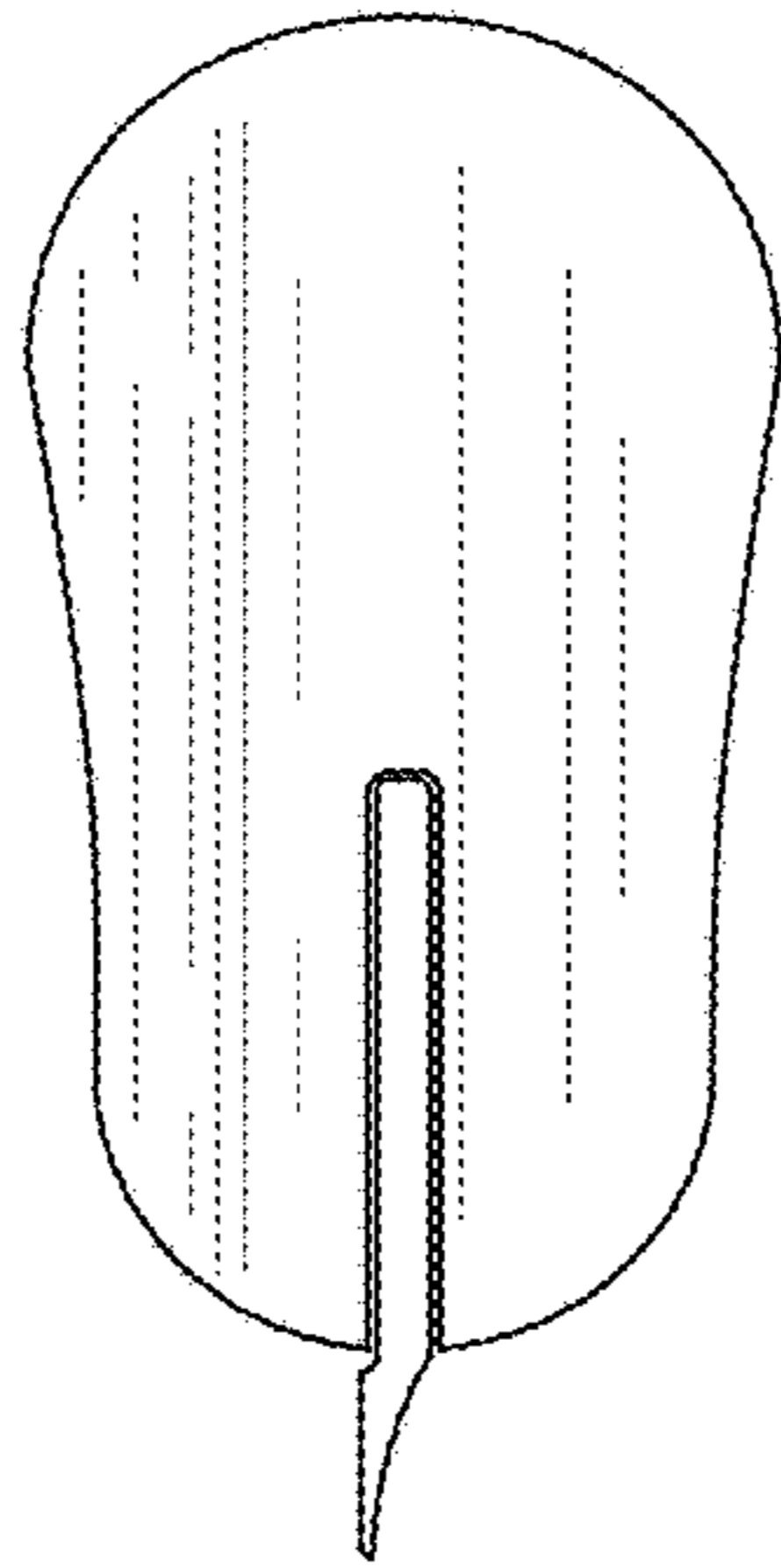

FIG. 3

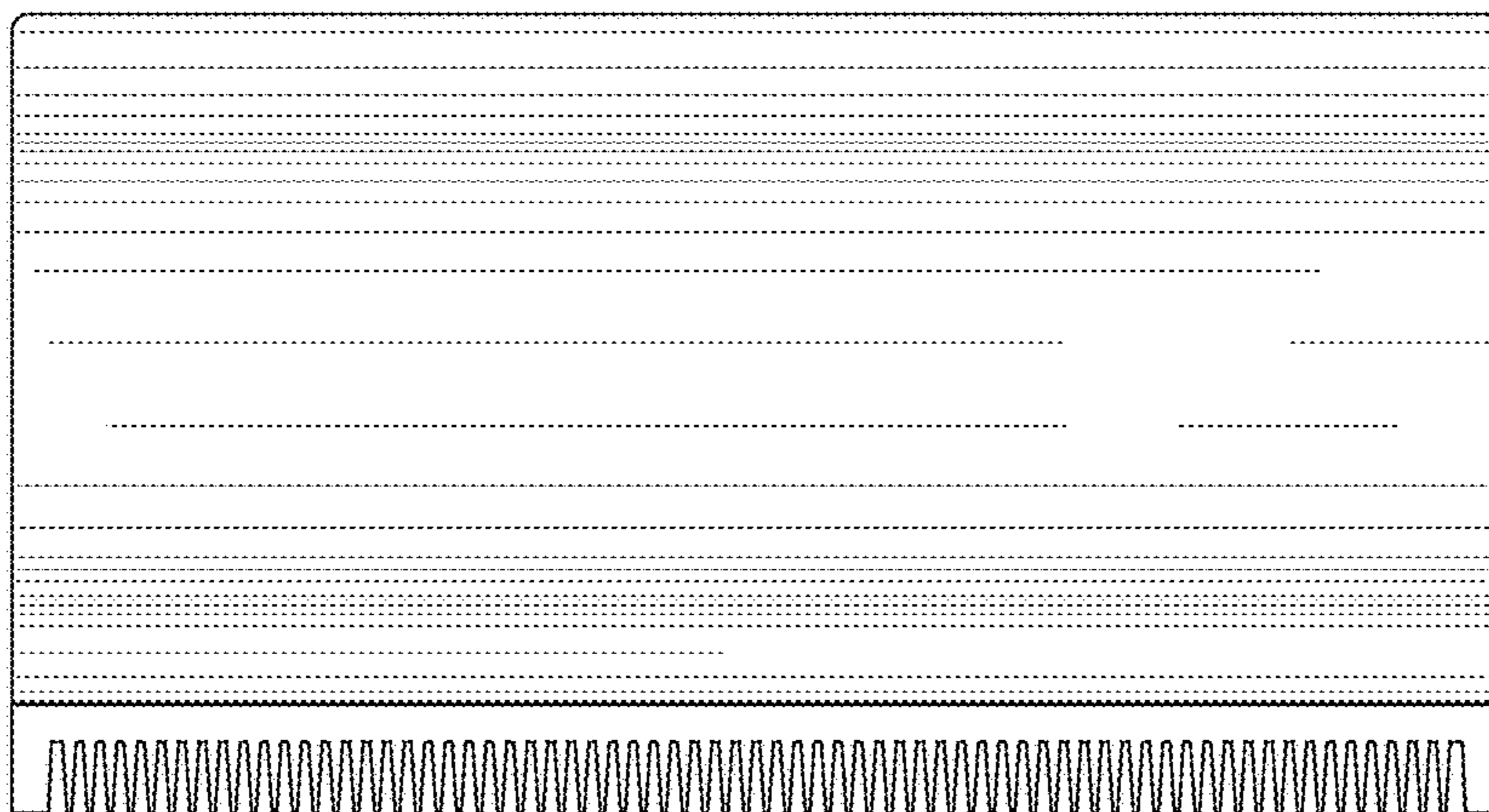

FIG. 4

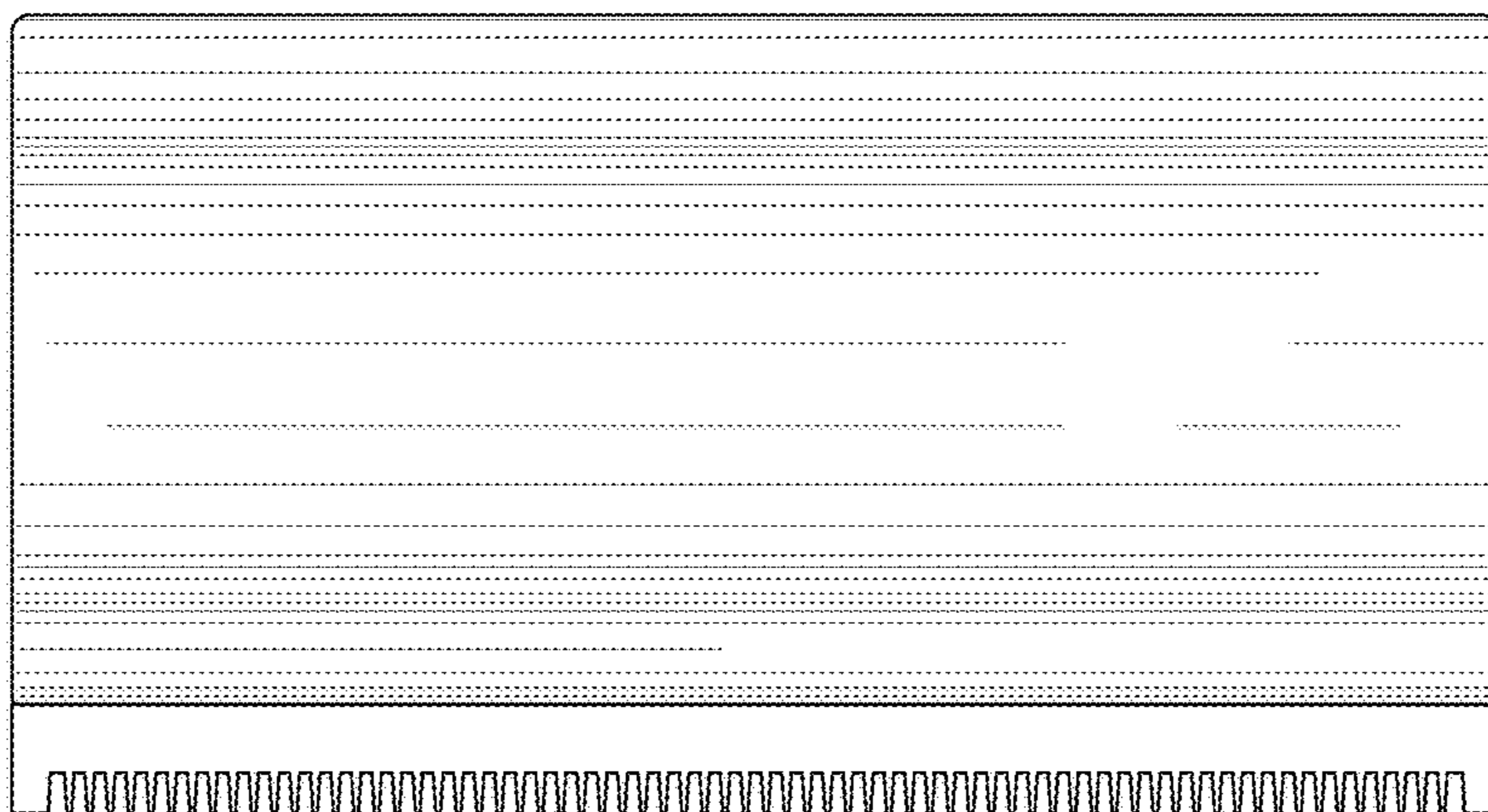

FIG. 5

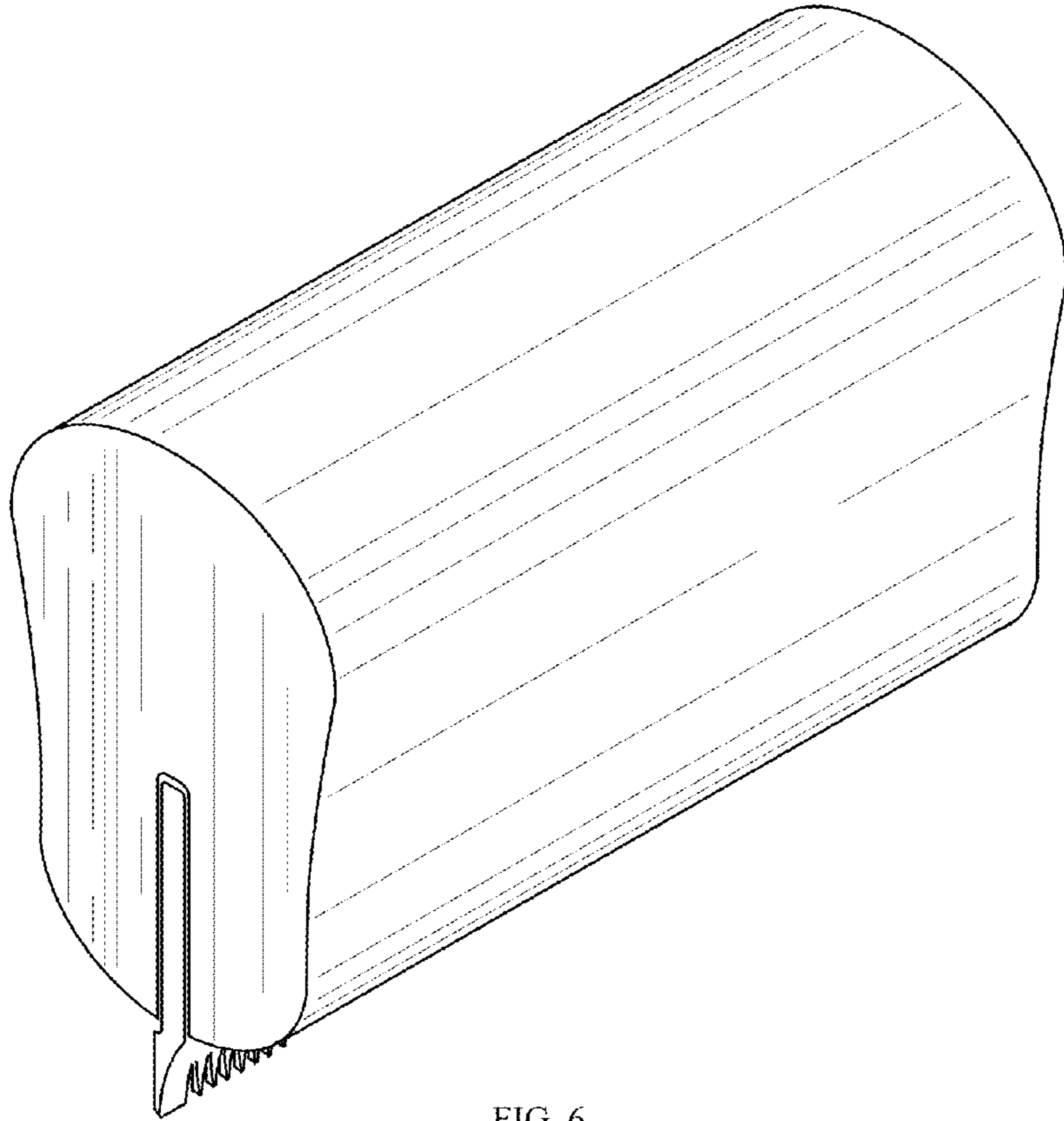

FIG. 6

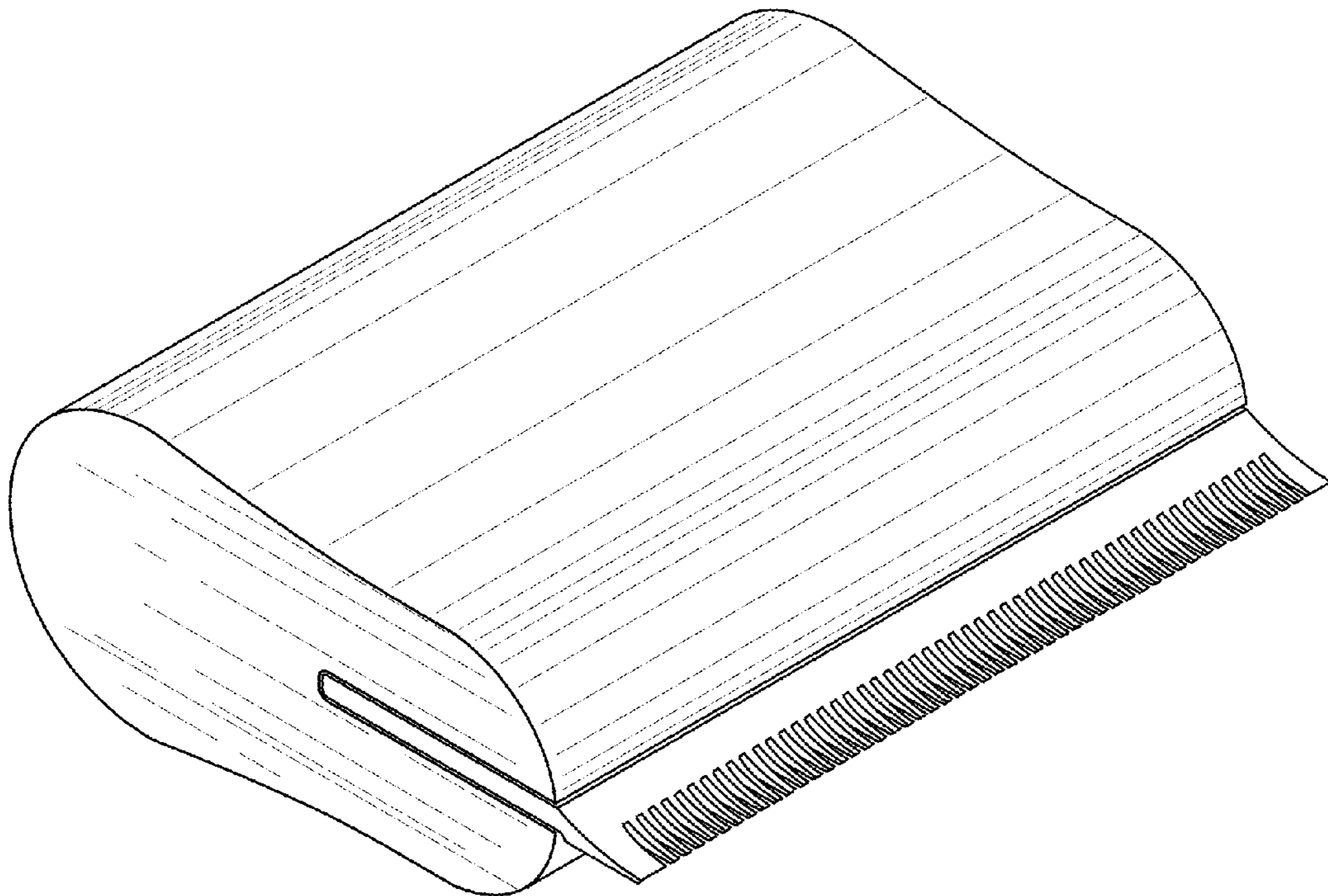

FIG. 7