



US00D837453S

(12) **United States Design Patent**
Angles-D'Auriac

(10) **Patent No.:** **US D837,453 S**

(45) **Date of Patent:** **** Jan. 1, 2019**

(54) **MAKE-UP PALETTE**

(71) Applicant: **SEPHORA**, Neuilly-sur-Seine (FR)

(72) Inventor: **Elizabeth Angles-D'Auriac**,
Neuilly-sur-Seine (FR)

(73) Assignee: **SEPHORA**, Neuilly-sur-Seine (FR)

(**) Term: **15 Years**

(21) Appl. No.: **29/617,920**

(22) Filed: **Sep. 17, 2017**

(30) **Foreign Application Priority Data**

Apr. 25, 2017 (EM) 003872803-0001

Apr. 25, 2017 (EM) 003872803-0002

(51) **LOC (11) Cl.** **28-03**

(52) **U.S. Cl.**
USPC **D28/83**

(58) **Field of Classification Search**

USPC D28/64.1, 76-84; D9/503-505, 722, 529,
D9/420; D3/295; D19/103, 106

CPC A45D 33/006; A45D 33/003; A45D
33/04-33/33; A45D 33/025; A45D 33/02;
A45D 33/20; A45D 33/22; A45D 33/24;
A45D 33/26; A45D 33/28; A45D 33/18;
A45D 40/22; A45D 40/222; A45D 40/24;
A45D 42/02

See application file for complete search history.

(56) **References Cited**

U.S. PATENT DOCUMENTS

D409,801 S * 5/1999 Kim D28/83
D469,223 S * 1/2003 Thorpe D28/83
D480,837 S * 10/2003 Liu D28/83
D597,256 S * 7/2009 Liden D28/83
D603,564 S * 11/2009 Liden D28/83
D638,582 S * 5/2011 Ohmoto D28/83
D688,008 S * 8/2013 Fama D19/103

D709,651 S * 7/2014 Gaito D28/83
D723,742 S * 3/2015 Shteytsel D28/83
D768,335 S * 10/2016 Parker D28/83

(Continued)

OTHER PUBLICATIONS

Trying the New Sephora Mixology Eyeshadow Palette, Aly Milano on youtube.com, published on Mar. 25, 2017, retrieved on Aug. 2, 2018, retrieved from the Internet URL: <https://www.youtube.com/watch?v=TGqrYk3HLO0>.*

Primary Examiner — Jennifer Rivard

Assistant Examiner — Alison M Ofstun

(74) *Attorney, Agent, or Firm* — King & Spalding LLP

(57) **CLAIM**

The ornamental design for a make-up palette, as shown and described.

DESCRIPTION

FIG. 1 is a top perspective view of a make-up palette, with the make-up palette closed, showing my new design;
FIG. 2 is a top plan view thereof;
FIG. 3 is a bottom plan view thereof;
FIG. 4 is a front elevation view thereof;
FIG. 5 is a back elevation view thereof;
FIG. 6 is a right side elevation view thereof, the left side elevation view being a mirror image of the right side elevation view;
FIG. 7 is a top perspective view of the make-up palette, with the make-up palette opened;
FIG. 8 is a top plan view of the make-up palette, with the make-up palette opened; and,
FIG. 9 is a left side elevation view of the make-up palette, with the make-up palette opened, the right side elevation view being a mirror image of the left side elevation view.
The broken lines shown in the figures depict portions of the make-up palette that form no part of the claimed design.

1 Claim, 8 Drawing Sheets

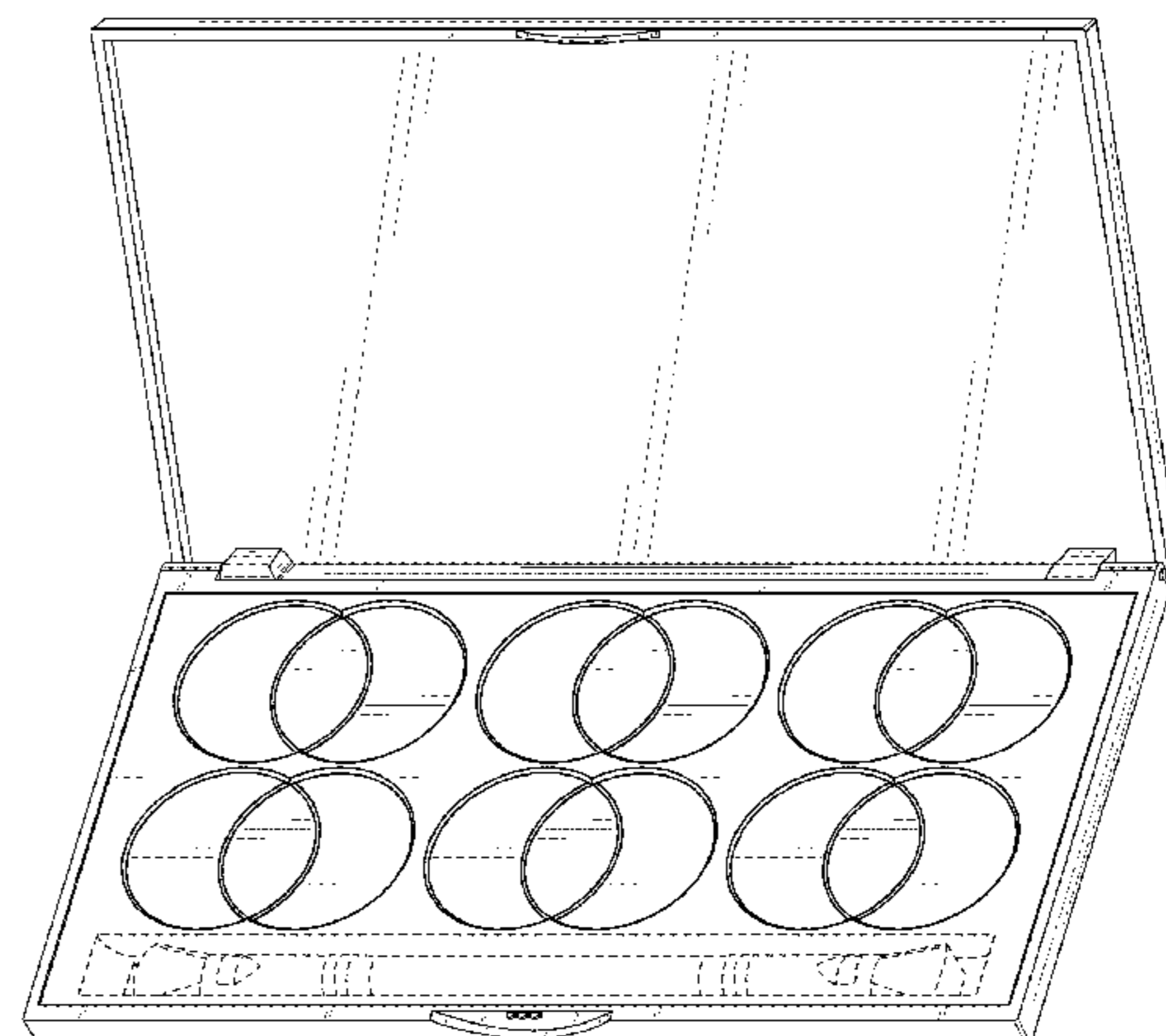
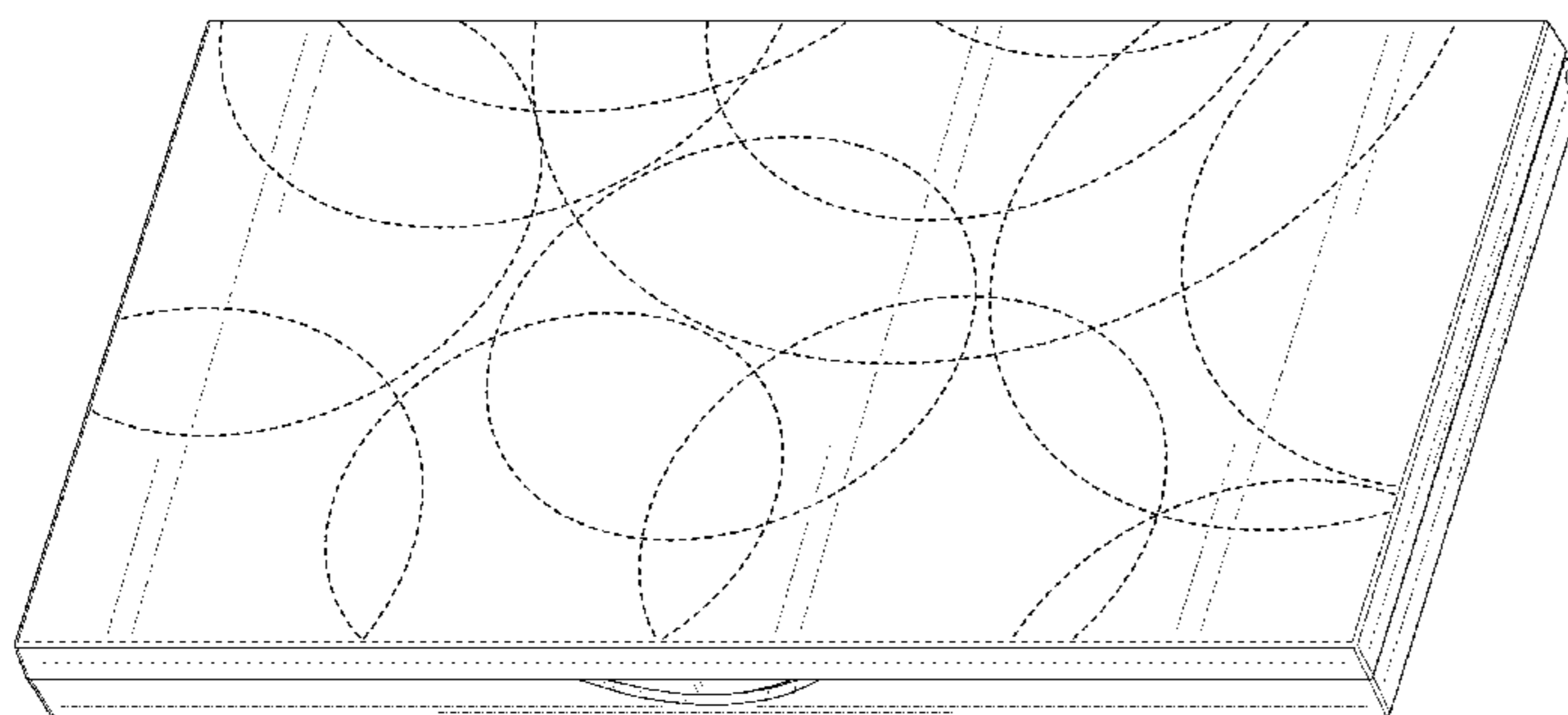

(56)

References Cited

U.S. PATENT DOCUMENTS

D768,935 S * 10/2016 Parker D28/83
D806,532 S * 1/2018 Richmond D9/420
2014/0299151 A1* 10/2014 Stroud A45D 33/008
132/315

* cited by examiner

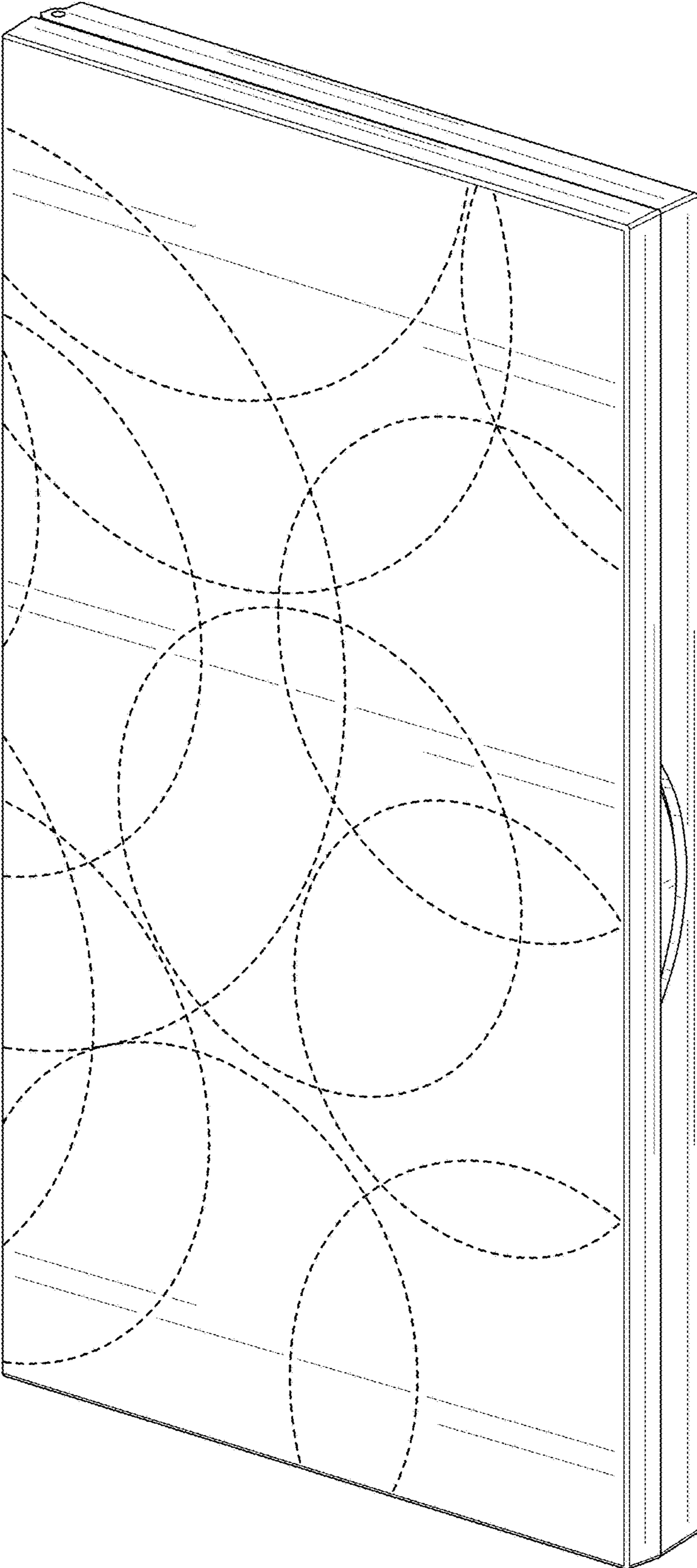

FIG. 1

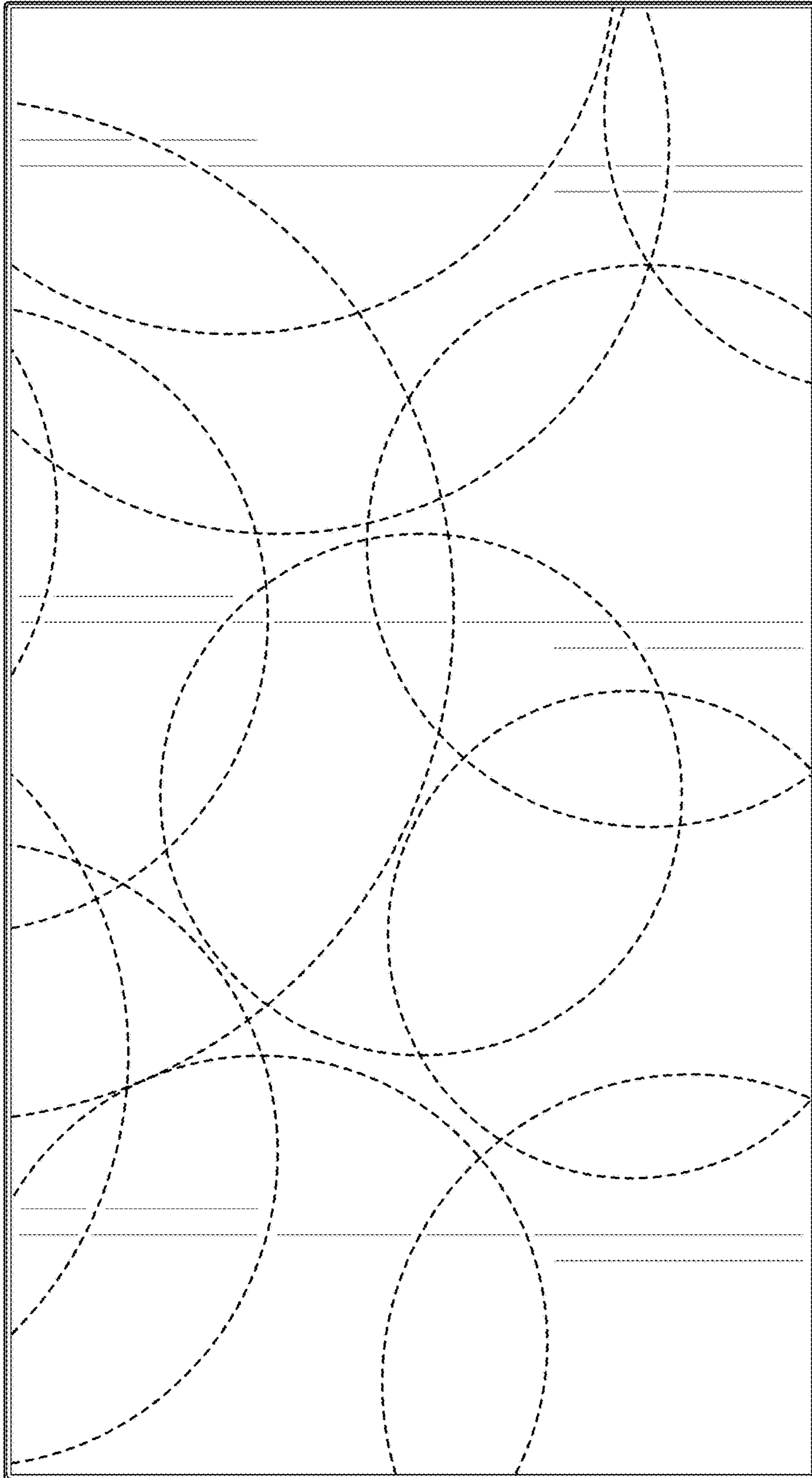

FIG. 2

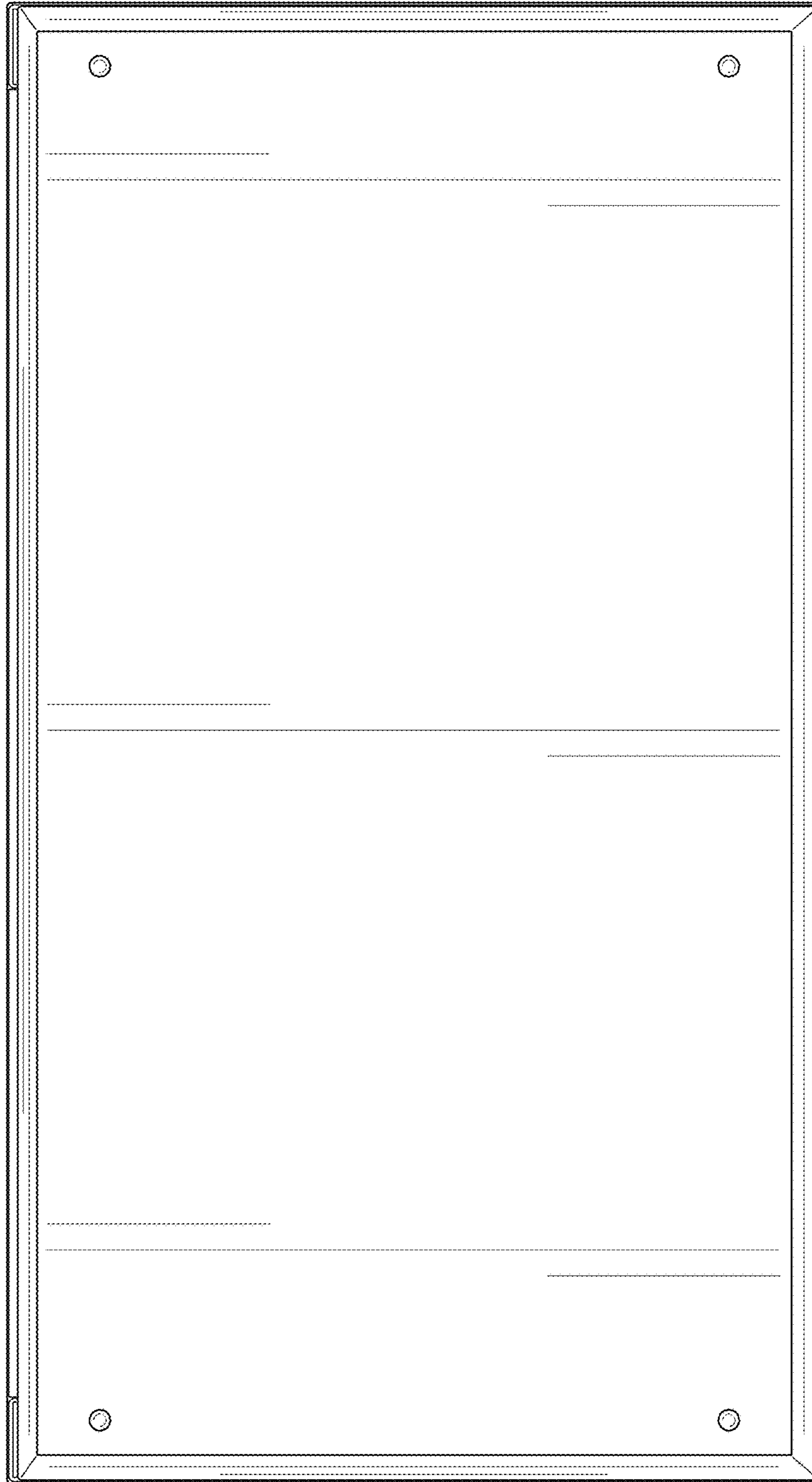

FIG. 3

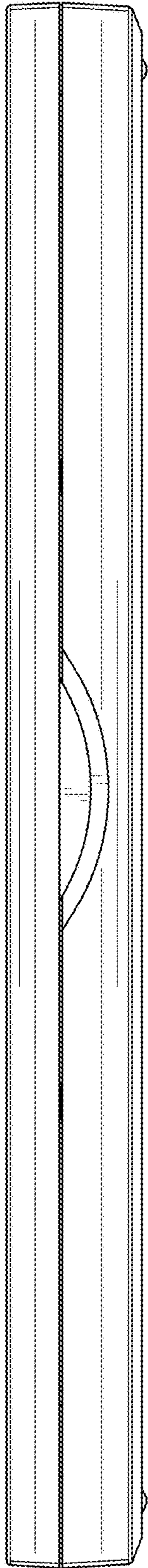

FIG. 4

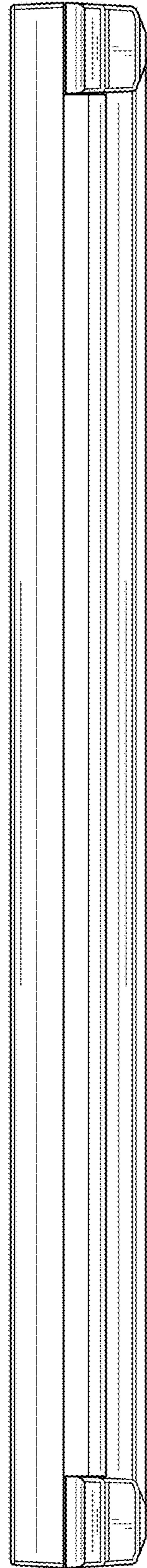

FIG. 5

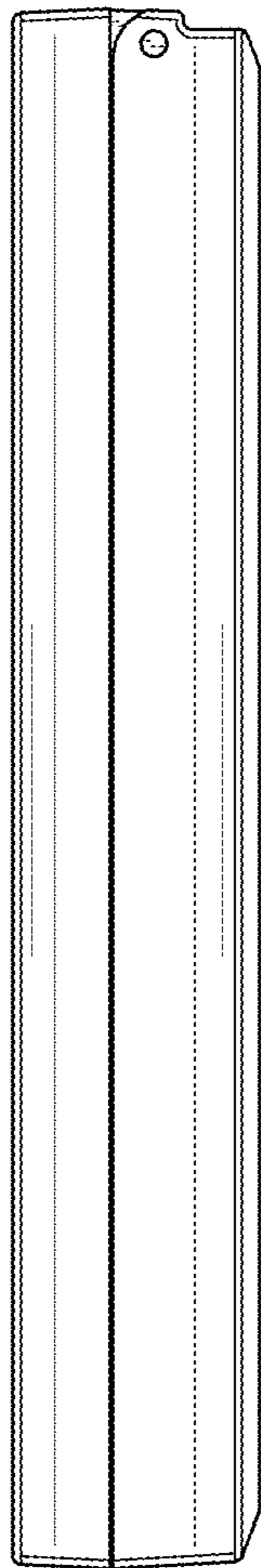

FIG. 6

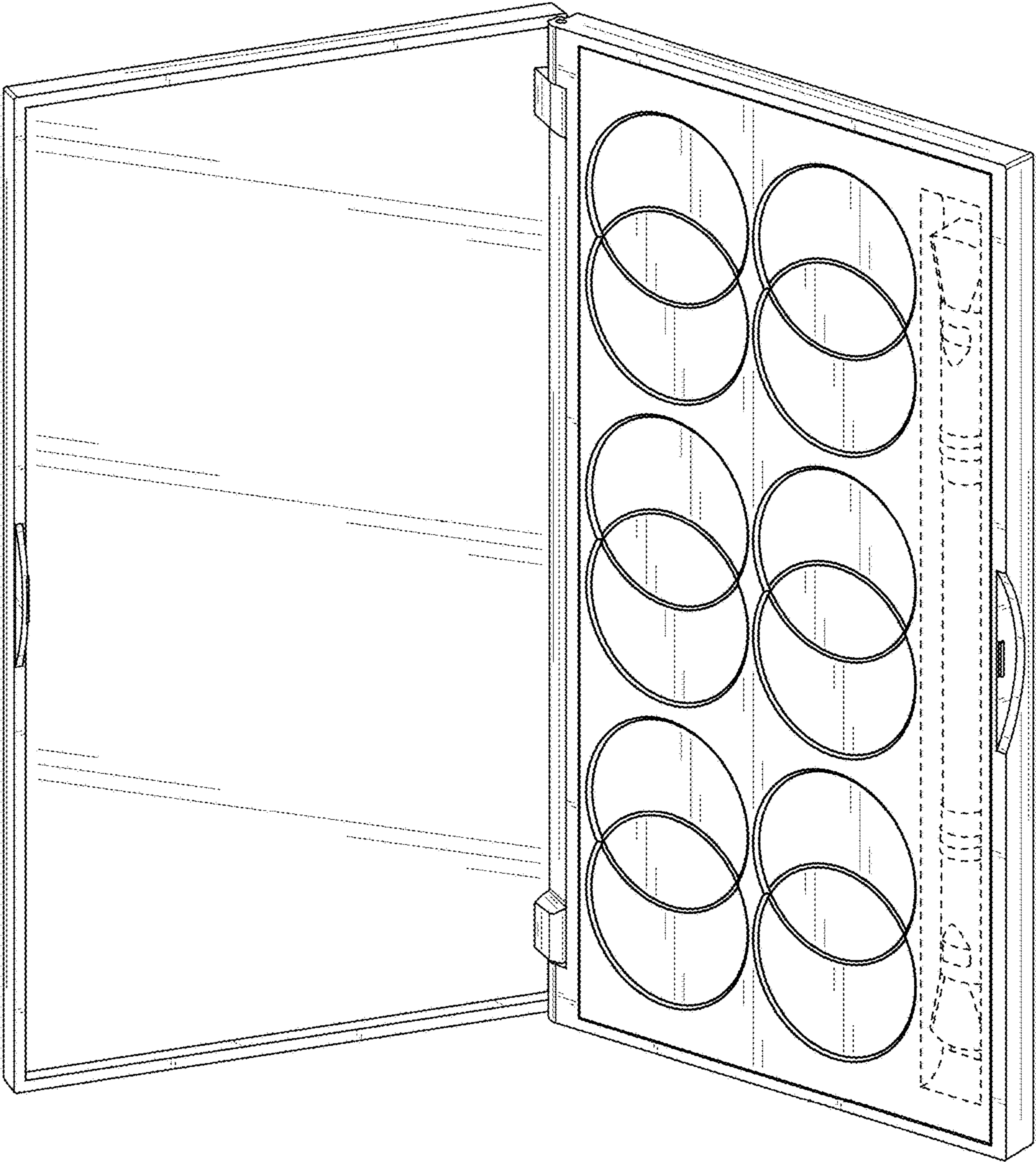

FIG. 7

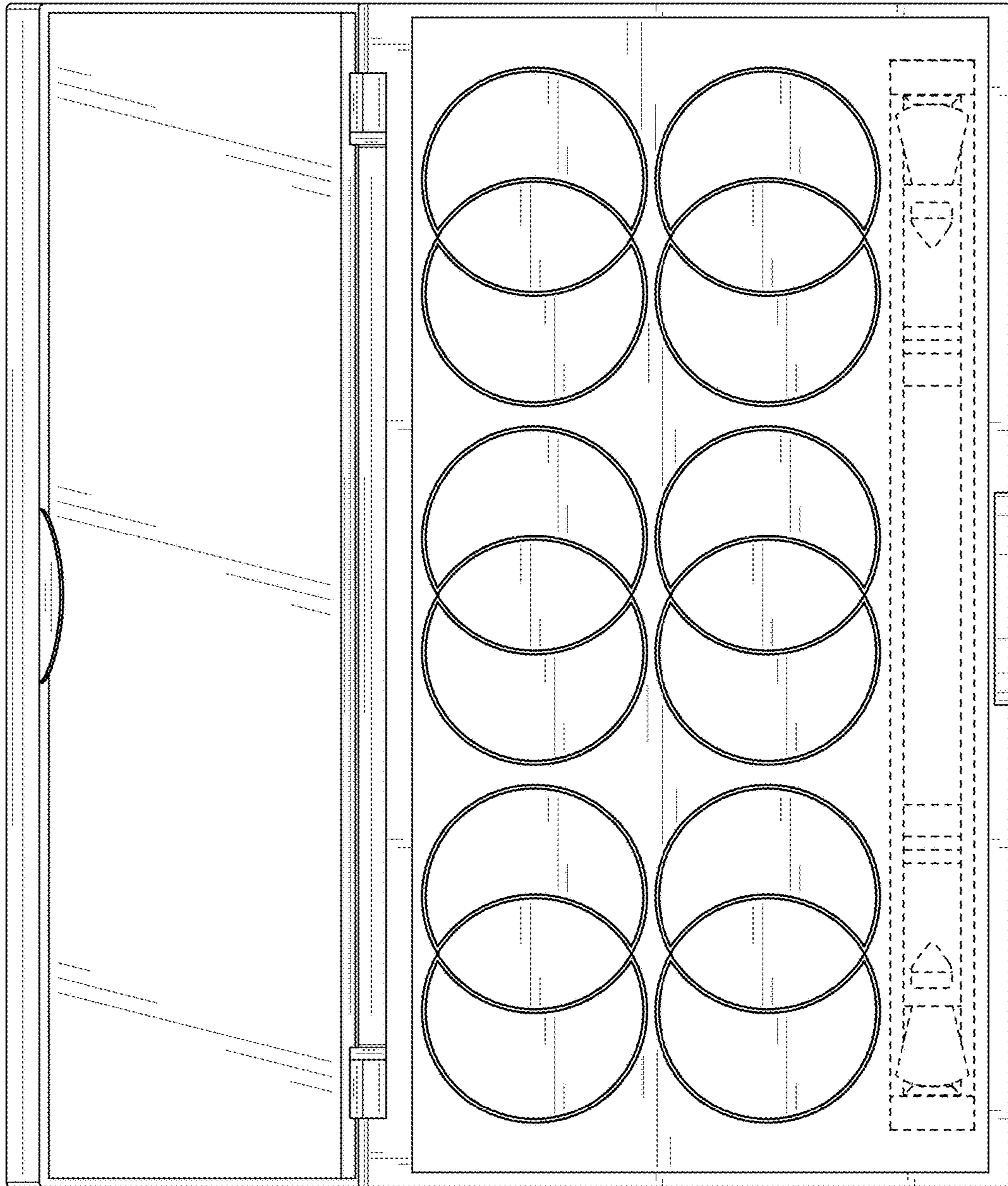

FIG. 8

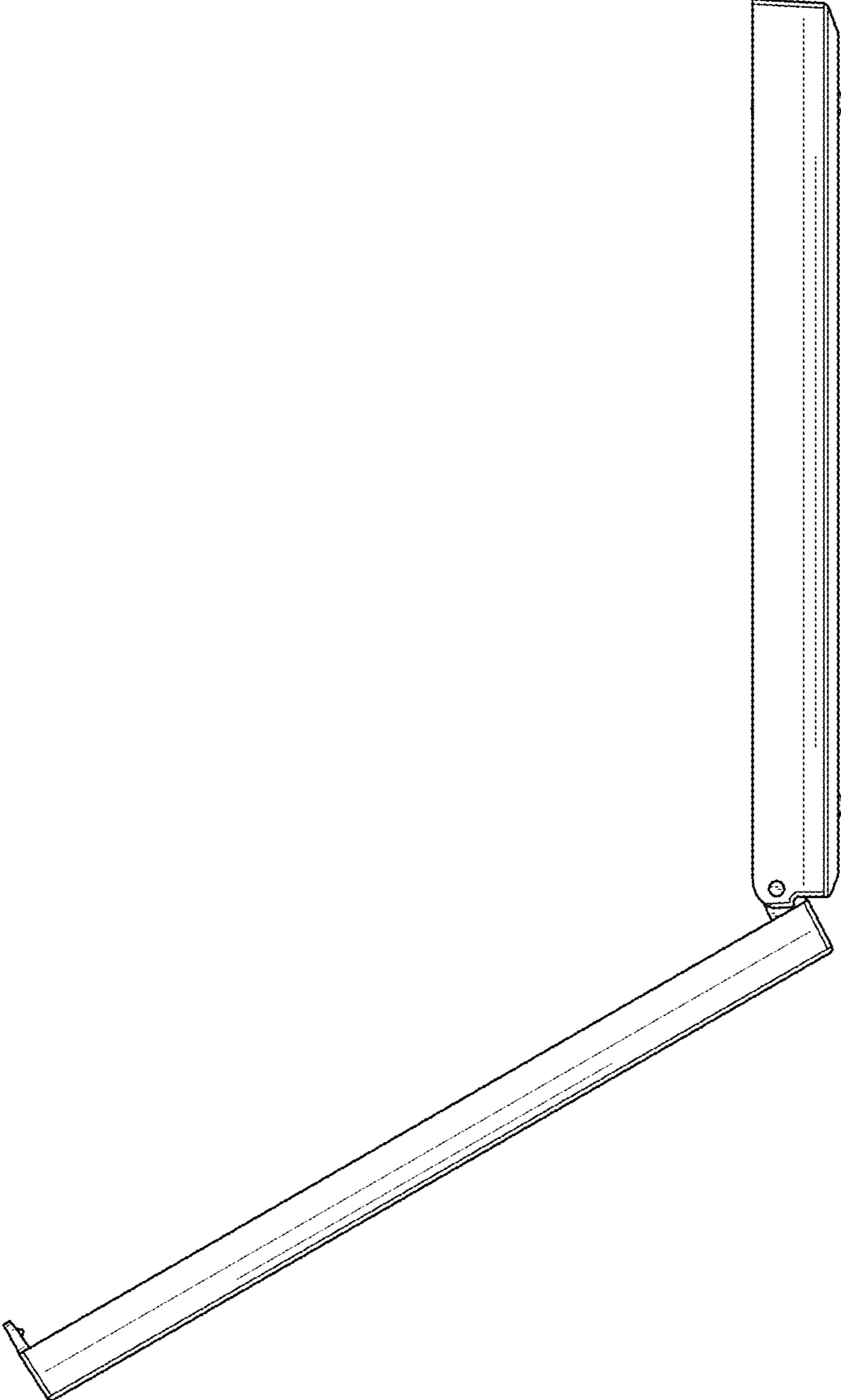

FIG. 9