



US00D837010S

(12) **United States Design Patent**  
**Bowers et al.**

(10) **Patent No.:** **US D837,010 S**  
(45) **Date of Patent:** **\*\* Jan. 1, 2019**

(54) **ELECTRIC KNIFE SHARPENER**  
(71) Applicant: **Lifetime Brands, Inc.**, Garden City,  
NY (US)  
(72) Inventors: **Noah Bowers**, Ridgewood, NY (US);  
**Stefano Benito Giuliani**, Rocky Point,  
NY (US)  
(73) Assignee: **Lifetime Brands, Inc.**, Garden City,  
NY (US)

6,802,763 B1 \* 10/2004 Leung ..... B24B 49/16  
451/193  
6,932,683 B2 \* 8/2005 Li ..... B24B 3/54  
451/193  
D604,133 S \* 11/2009 Smith ..... D8/63  
D632,153 S \* 2/2011 Walker ..... D8/93  
D652,284 S \* 1/2012 Elek ..... D8/93  
D688,545 S \* 8/2013 Jensen ..... D8/63  
D705,625 S \* 5/2014 Huber ..... D8/63  
D803,648 S \* 11/2017 Elek ..... D8/63

\* cited by examiner

(\*\*) Term: **15 Years**

*Primary Examiner* — Philip S Hyder

(74) *Attorney, Agent, or Firm* — Tutunjian & Bitetto, P.C.

(21) Appl. No.: **29/600,984**

(57) **CLAIM**

(22) Filed: **Apr. 18, 2017**

The ornamental design for an electric knife sharpener, as shown and described.

(51) **LOC (11) Cl.** ..... **08-05**

(52) **U.S. Cl.**  
USPC ..... **D8/63**

**DESCRIPTION**

(58) **Field of Classification Search**  
USPC ..... D8/63, 90, 91, 92, 93  
CPC .... B24B 3/54; B24B 3/36; B24B 3/58; B24B  
3/00; B24B 23/08; B24B 15/00; B24B  
15/06; B24B 15/063; B24B 15/08  
See application file for complete search history.

FIG. 1 is a rear perspective view of the perspective view of the electric knife sharpener showing my new design;  
FIG. 2 is a front view thereof;  
FIG. 3 is a rear view thereof;  
FIG. 4 is a left side view thereof;  
FIG. 5 is a rights side view thereof;  
FIG. 6 is a top view thereof; and,  
FIG. 7 is a bottom view thereof.

The broken lines in the drawings are for illustrative purposes only and form no part of the claimed design.

(56) **References Cited**

**U.S. PATENT DOCUMENTS**

D328,410 S \* 8/1992 Friel ..... D8/63  
D409,891 S \* 5/1999 Friel ..... D8/63

**1 Claim, 6 Drawing Sheets**

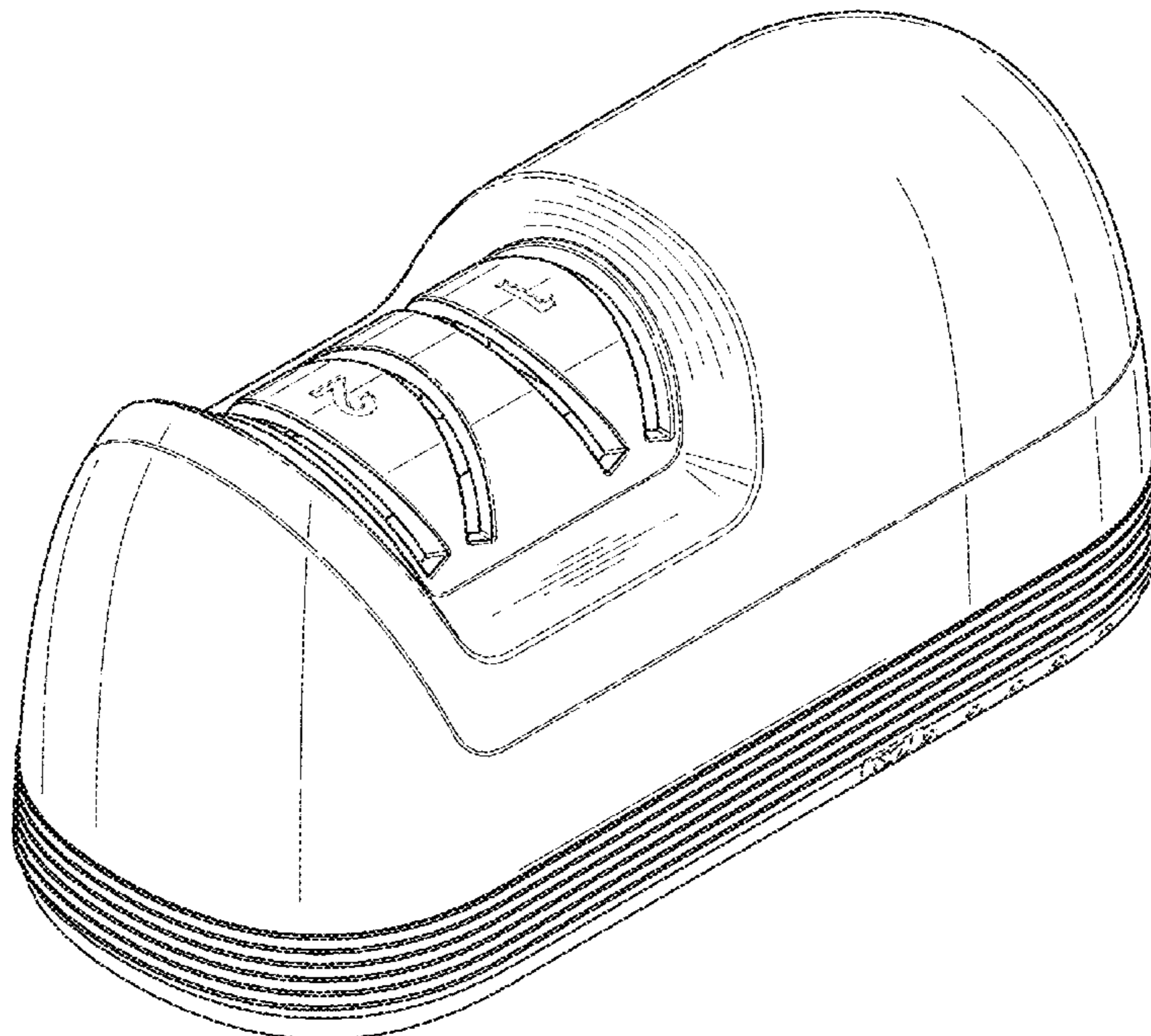

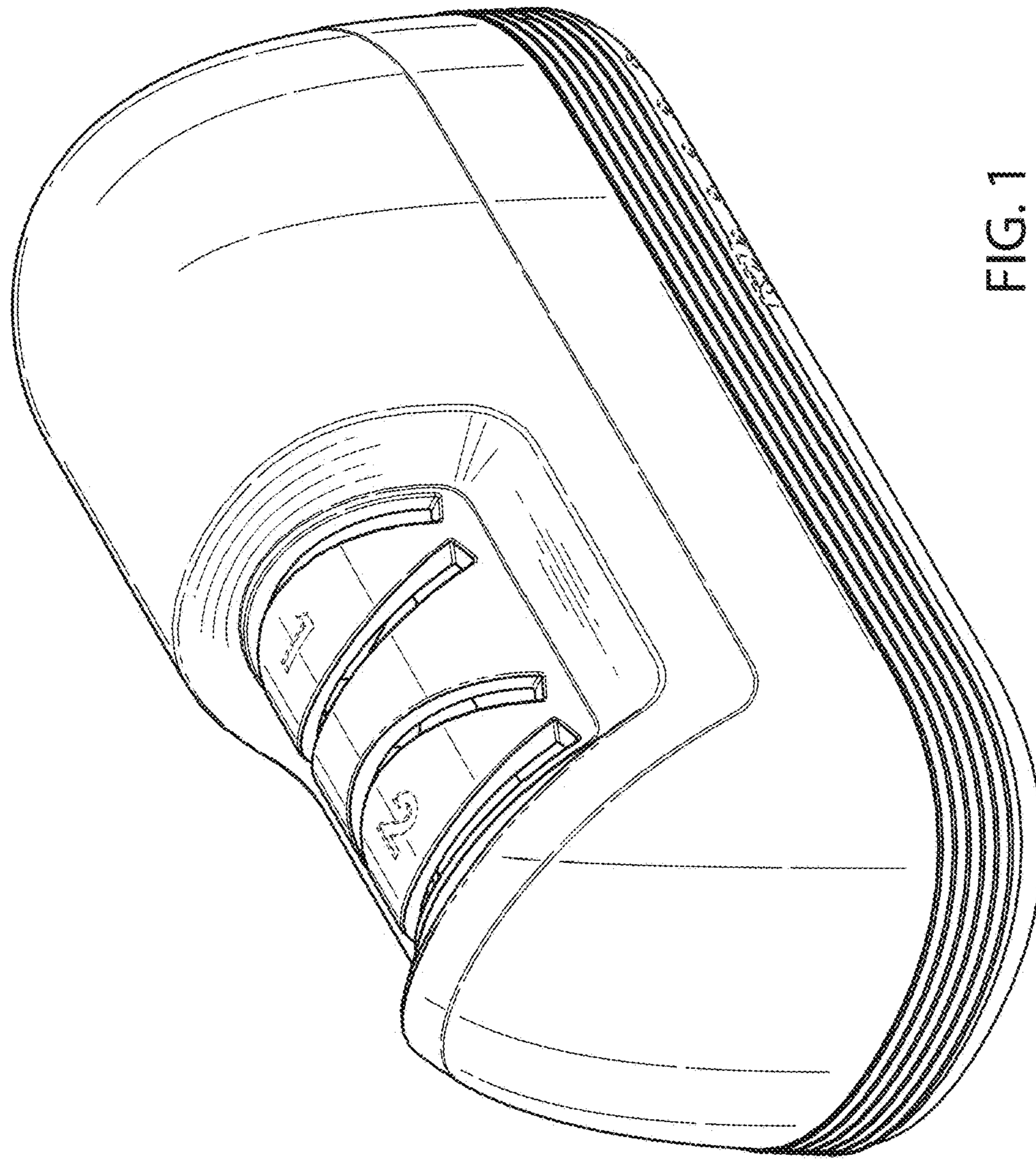

FIG. 1

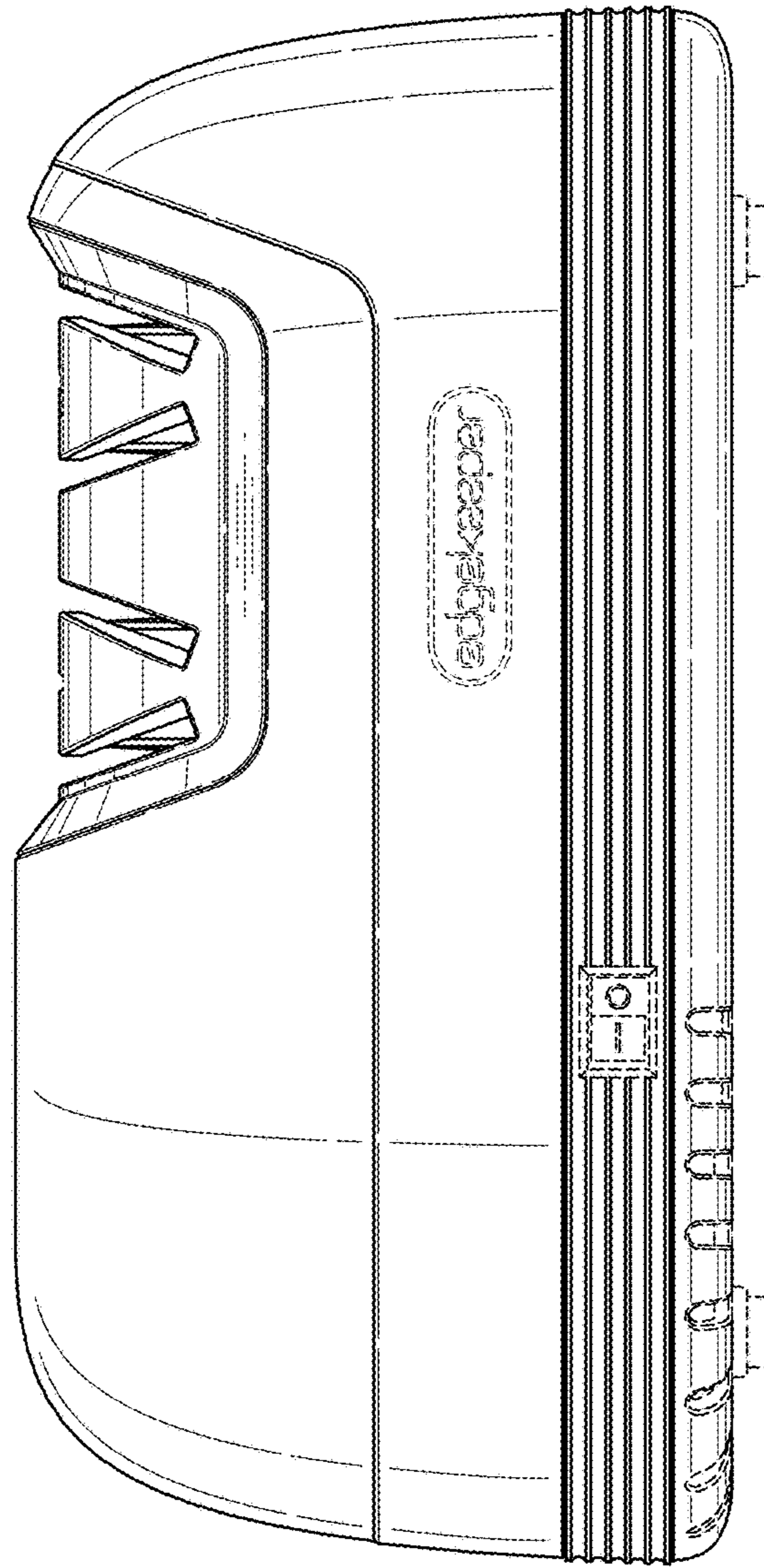

FIG. 2

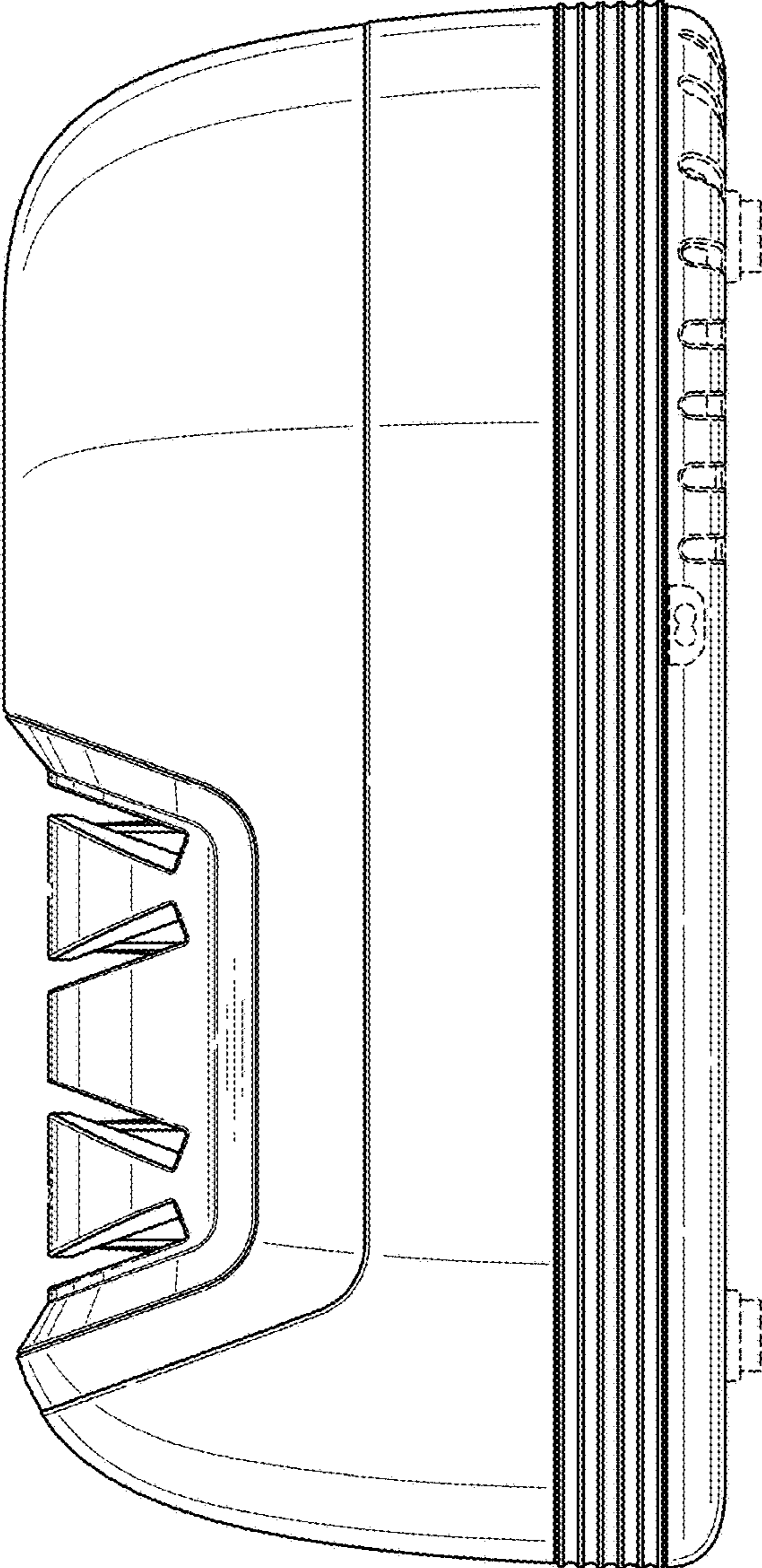

FIG. 3

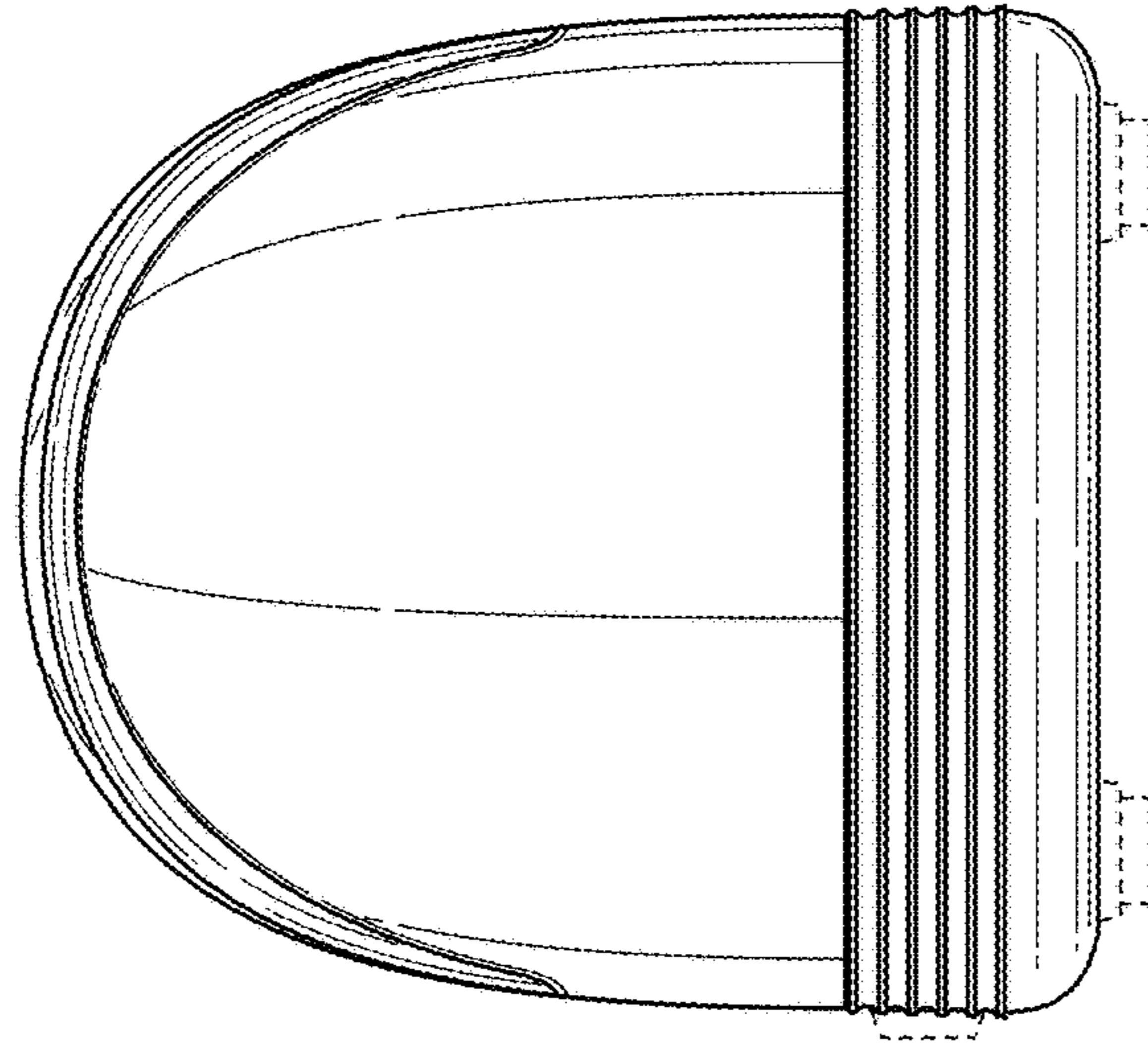

FIG. 5

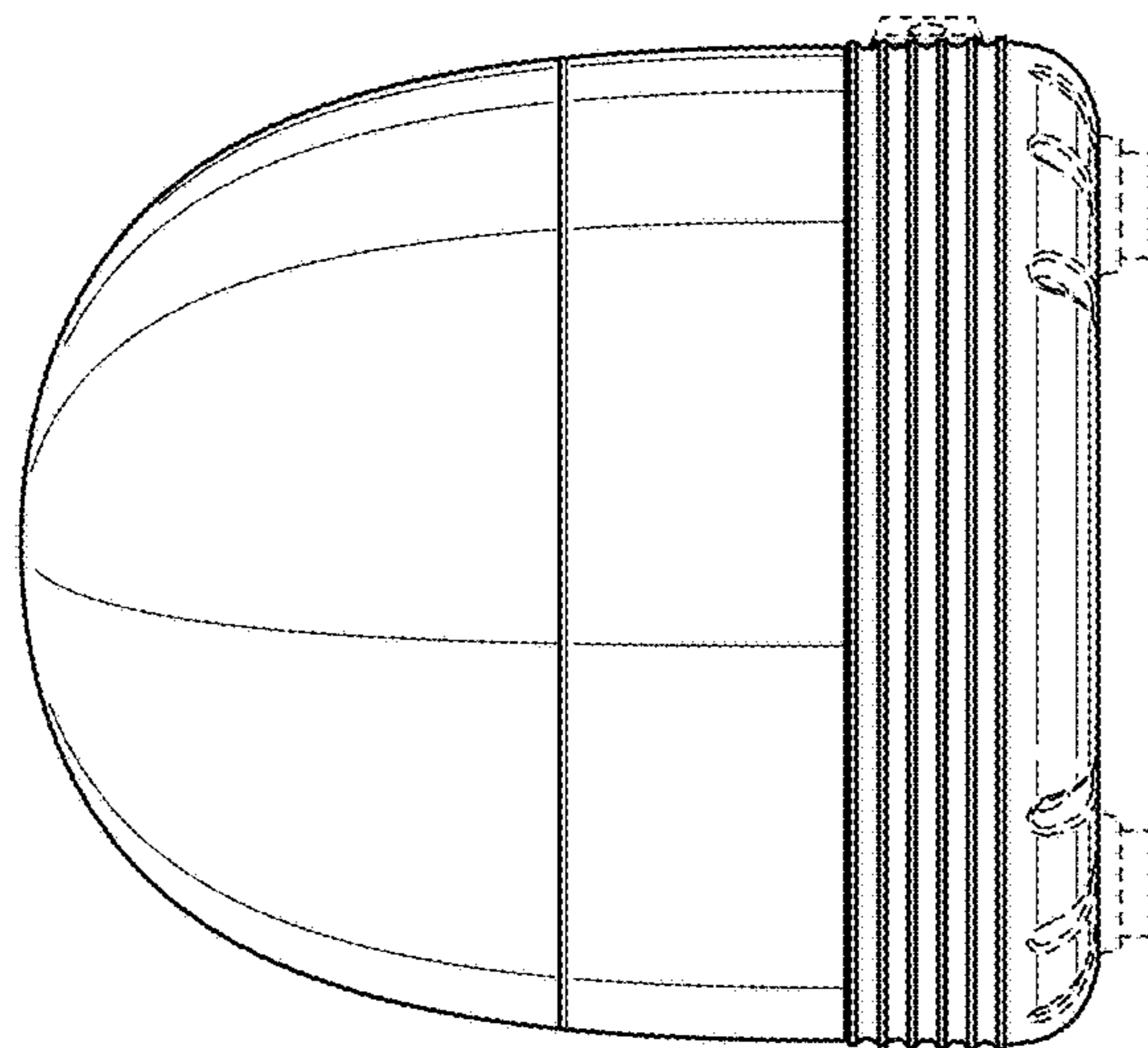

FIG. 4

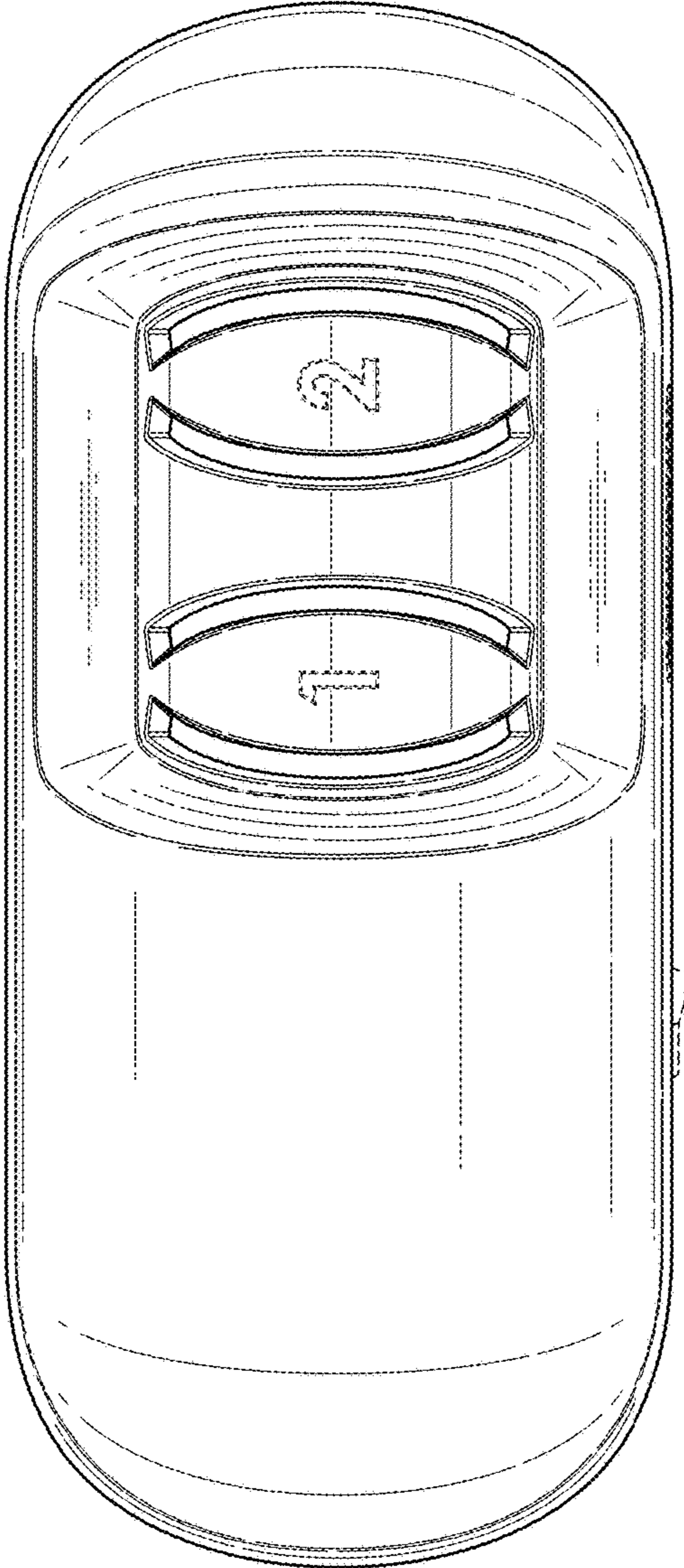

FIG. 6

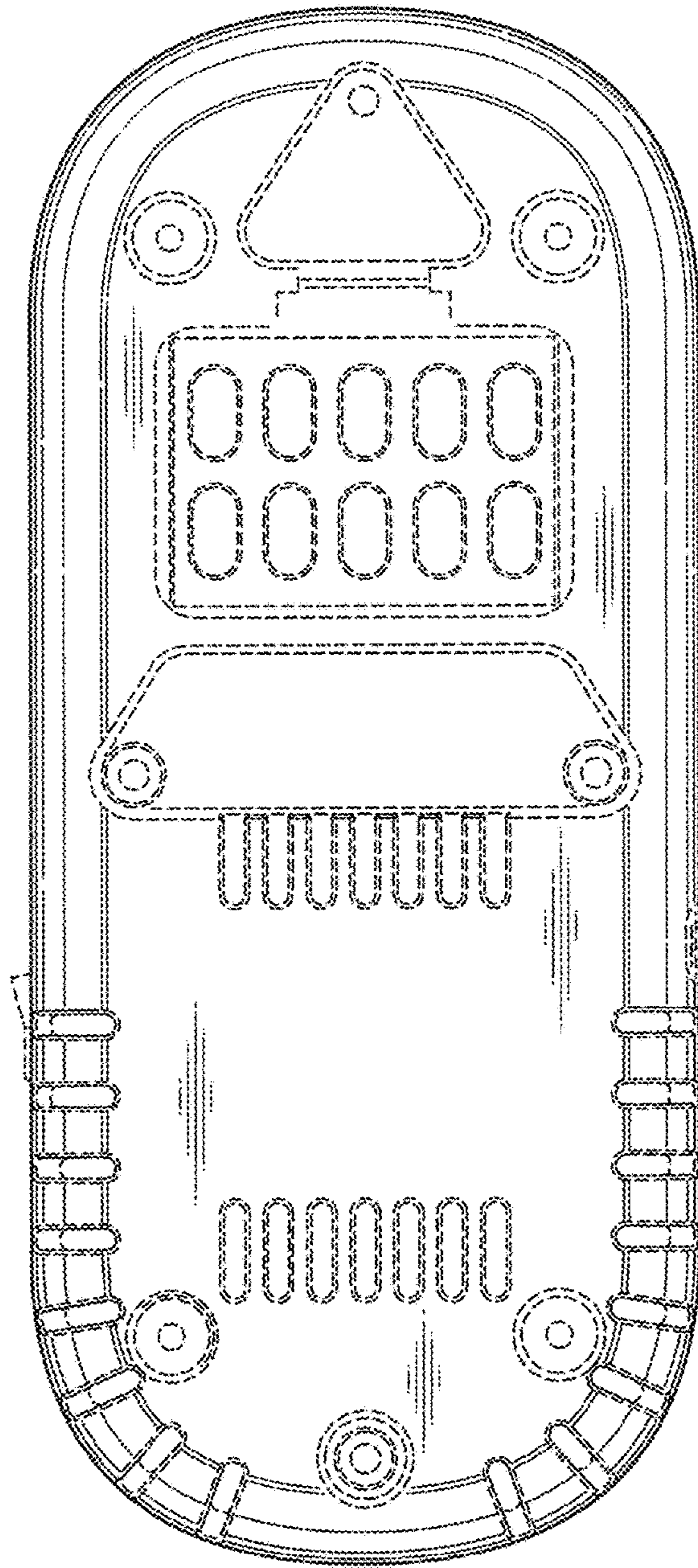

FIG. 7