



US00D836961S

(12) **United States Design Patent** (10) **Patent No.:** **US D836,961 S**
Bobba et al. (45) **Date of Patent:** **** Jan. 1, 2019**

(54) **ARMREST**

(71) Applicant: **SABIC Global Technologies B.V.**,
Bergen op Zoom (NL)
(72) Inventors: **Somasekhar Bobba**, Pittsfield, MA
(US); **Ashwin Kumar**, Bangalore (IN);
Rahul Sagare, Selkirk, NY (US); **Raj**
Kumar, Bangalore (IN); **Kylie Speirs**,
Pittsfield, MA (US); **Andy May**,
Pittsfield, MA (US)

(73) Assignee: **SABIC GLOBAL TECHNOLOGIES**
B.V. (NL)

(**) Term: **15 Years**

(21) Appl. No.: **29/560,213**

(22) Filed: **Apr. 4, 2016**

(51) **LOC (11) Cl.** **06-01**

(52) **U.S. Cl.**
USPC **D6/716.2**

(58) **Field of Classification Search**
USPC D6/334-336, 356, 367, 368, 374, 716,
D6/716.1, 716.2, 716.4
CPC A47C 7/54; A47C 7/546; A47C 7/543;
B60N 2/75; B60N 2/753; B60N 2/757;
B60N 2/763
See application file for complete search history.

(56) **References Cited**

U.S. PATENT DOCUMENTS

D426,392 S * 6/2000 Ott D6/356
D665,588 S * 8/2012 Wada D6/356
D693,617 S * 11/2013 Koski D6/716.2
9,114,773 B2 8/2015 Sundararajan et al.

(Continued)

FOREIGN PATENT DOCUMENTS

DE 102015207292 10/2015
JP 2003289986 A 10/2003
WO WO 2010132573 11/2010

OTHER PUBLICATIONS

Brown, "Flying on the Inaugural Boeing 747-8 Intercontinental Flight With Lufthansa", *AirlineReporter*, 2012. Retrieved from <http://www.airlinereporter.com/2012/06/flying-on-the-inaugural-boeing-747-8-intercontinental-flight-with-lufthansa/> on Aug. 29, 2016.

(Continued)

Primary Examiner — Mimosa De
(74) *Attorney, Agent, or Firm* — Norton Rose Fulbright
US LLP

(57) **CLAIM**

The ornamental designs for armrest, as shown and described.

DESCRIPTION

FIG. 1 is a rear perspective view of our designs;
FIG. 2 is a left side view, which is a mirror image of a right side view;
FIG. 3 is a top view;
FIG. 4 is a bottom view;
FIG. 5 is a front view, which is enlarged for clarity; and,
FIG. 6 is a back view, which is enlarged for clarity.
The dashed lines in the figures form no part of the claimed designs. A dash-dot line in a figure is a boundary that the design depicted in the figure extends to, but does not include. Surface shading in the figures is provided solely to indicate contour. All other surface(s) or portion(s) of our armrest not shown in the figures or otherwise described in the specification form no part of the claimed designs.
In other embodiments of our designs, dashed line(s) indicating any unclaimed feature(s) may be replaced with solid line(s) to claim those feature(s), solid line(s) indicating any claimed feature(s) may be replaced with dashed line(s) so as not to claim those feature(s), and/or dash-dot line(s) indicating boundar(ies) may be deleted.

1 Claim, 6 Drawing Sheets

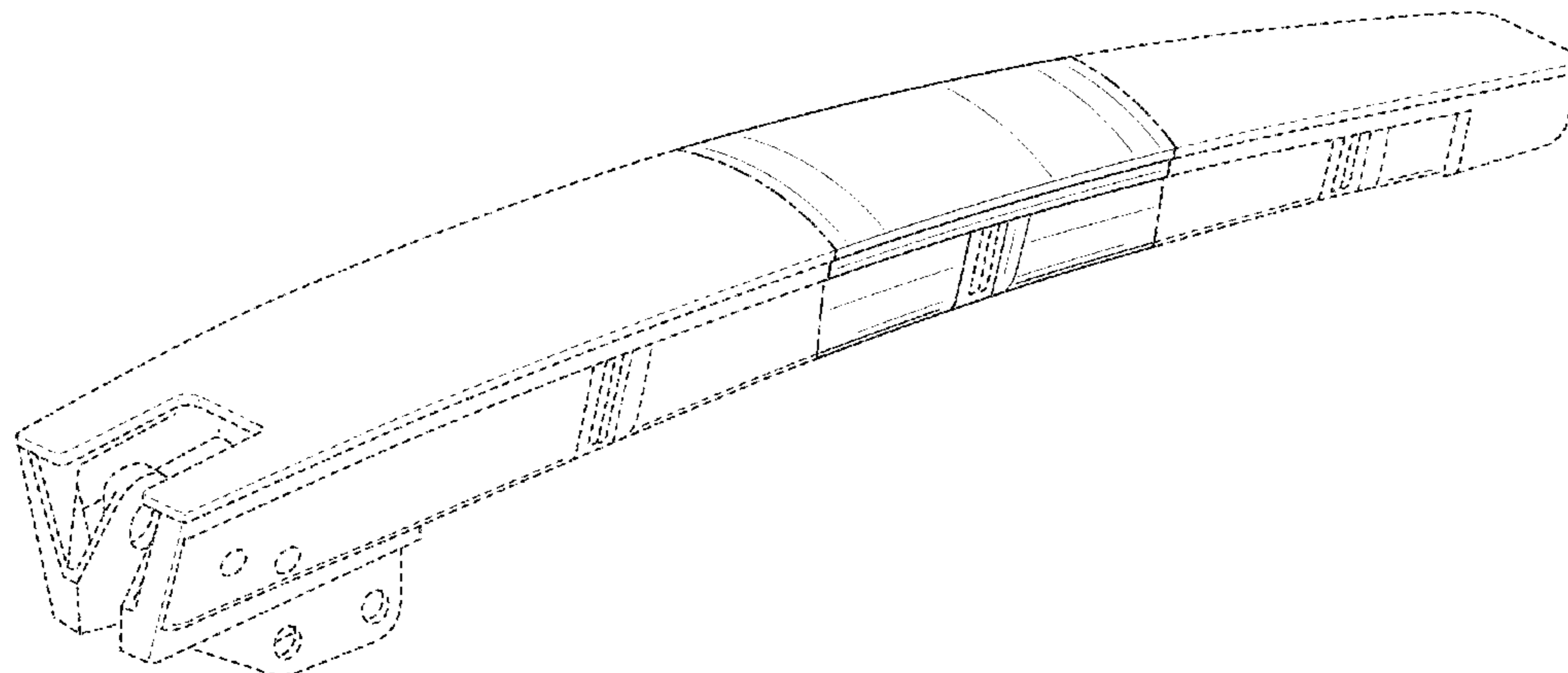

(56)

References Cited

U.S. PATENT DOCUMENTS

9,986,841	B2 *	6/2018	McMillan	A47C 7/54
2011/0272991	A1	11/2011	Saxton	297/411.46
2012/0146381	A1	6/2012	Spooner et al.	297/411.46
2016/0039387	A1	2/2016	Taubert et al.	297/117

OTHER PUBLICATIONS

Soarigami, "Design: Proof of Concept", 2015. Retrieved from <http://www.soarigami.com/products/soarigami> on Oct. 2, 2016.

* cited by examiner

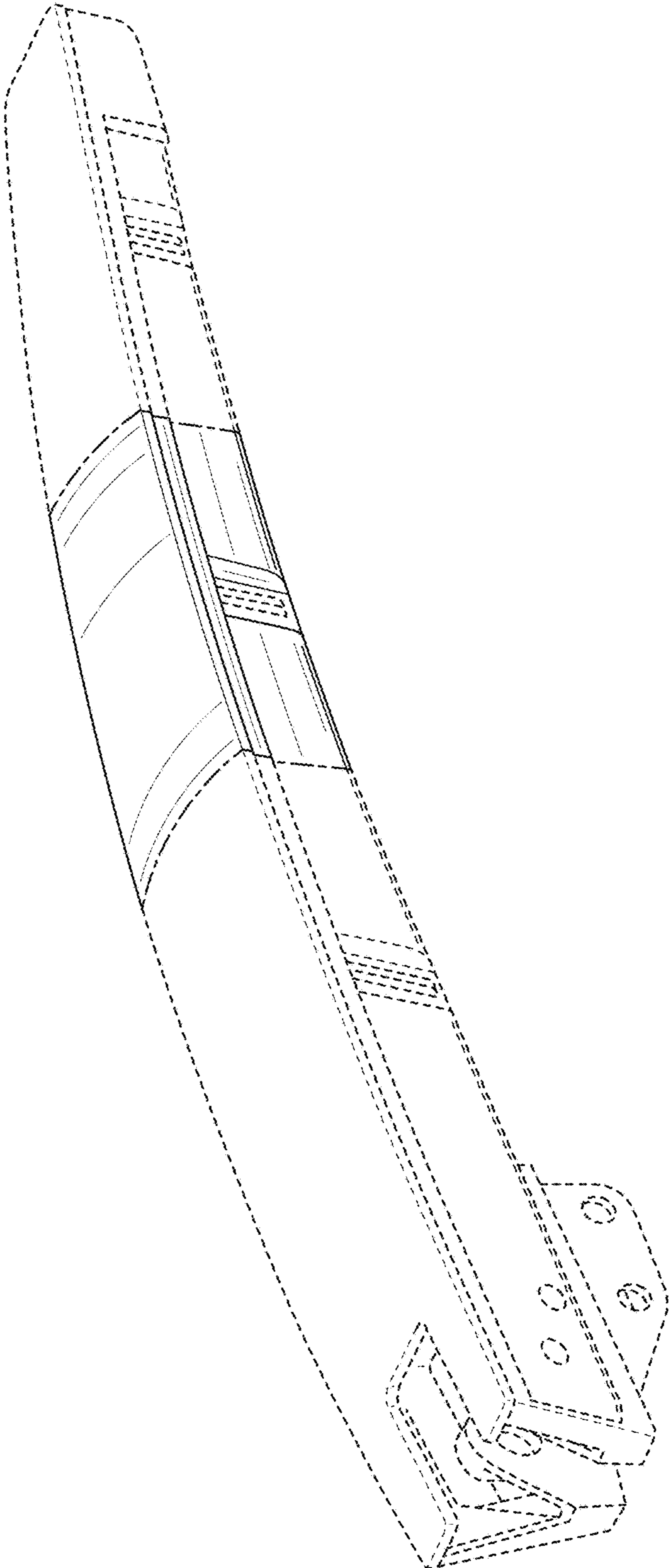

FIG. 1

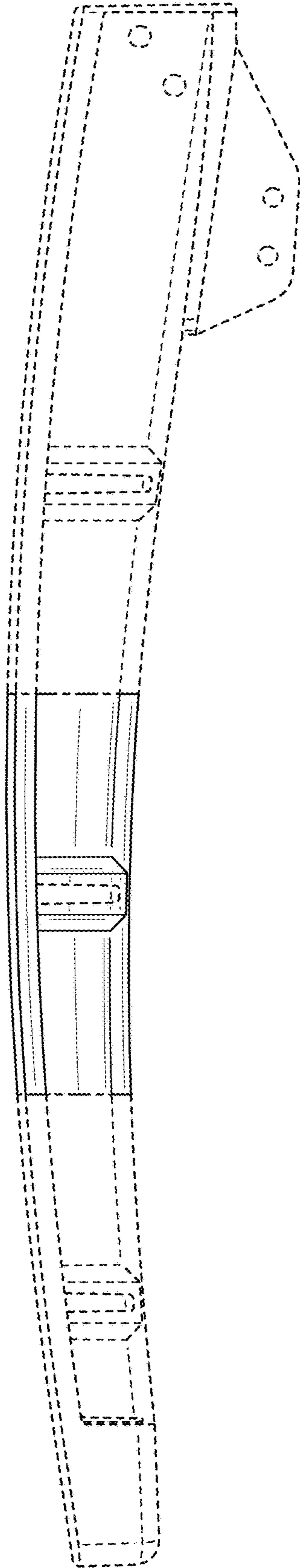

FIG. 2

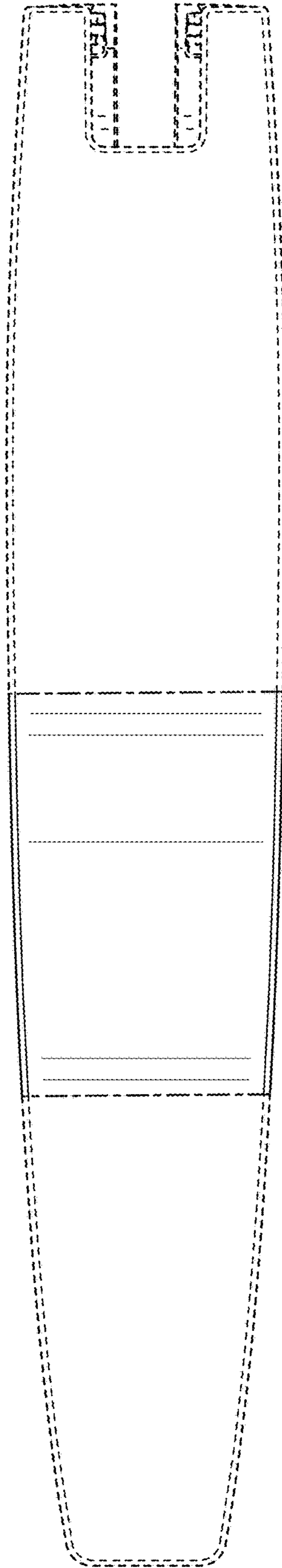

FIG. 3

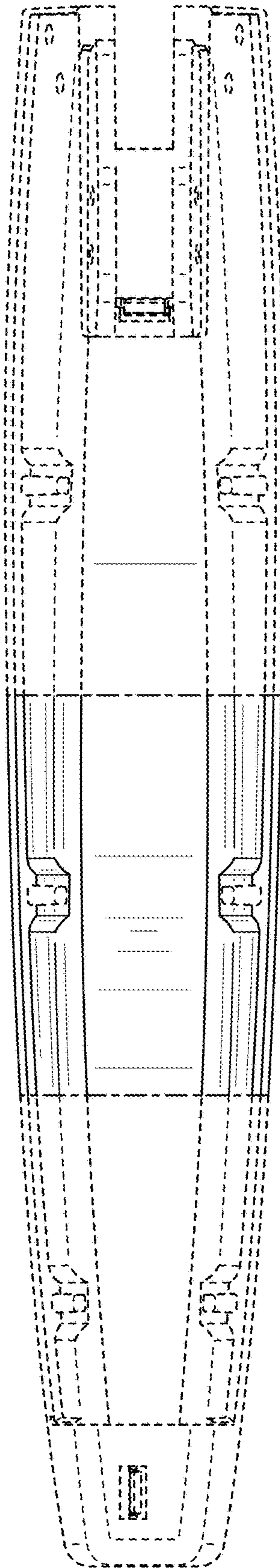

FIG. 4

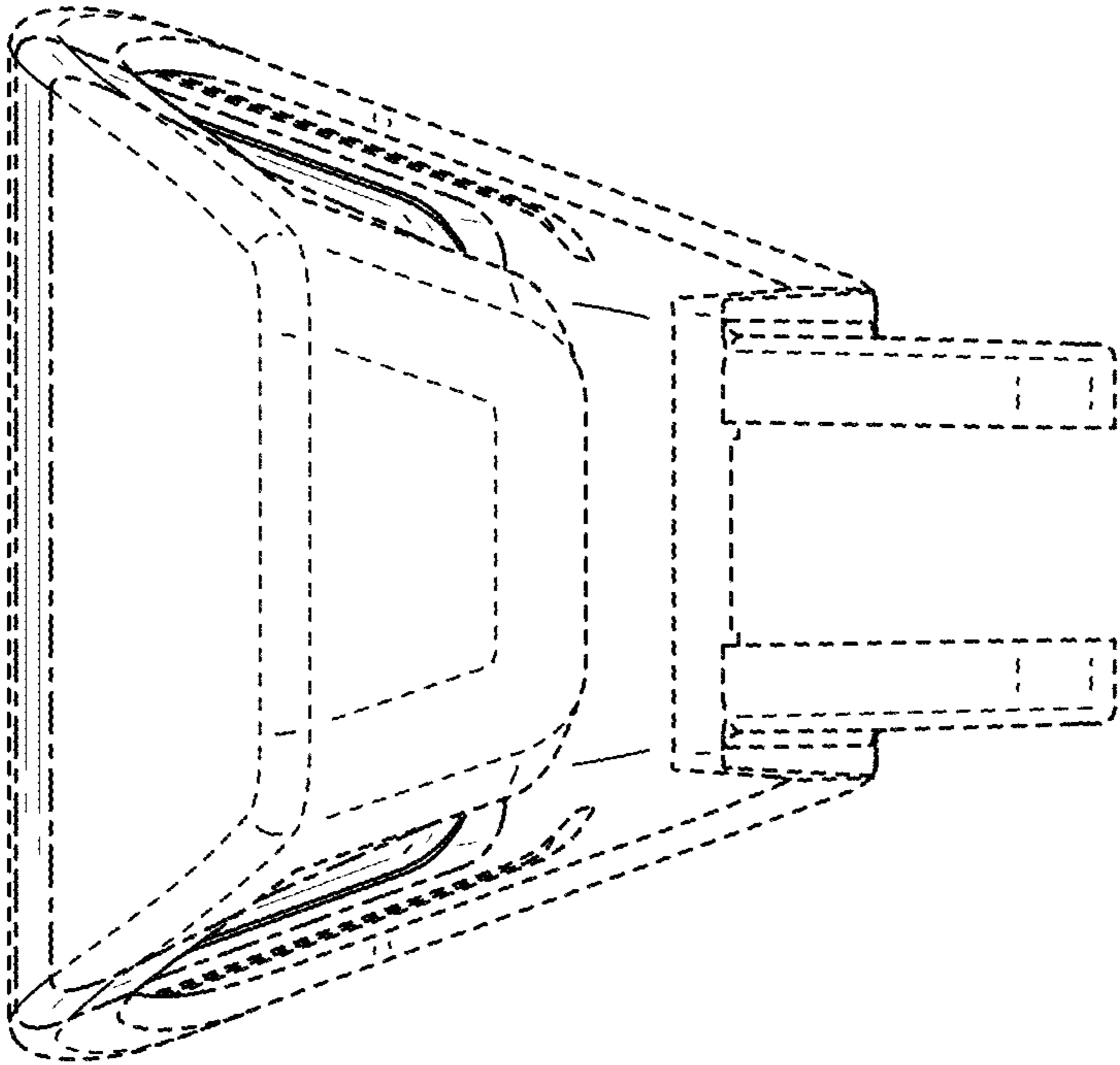

FIG. 5

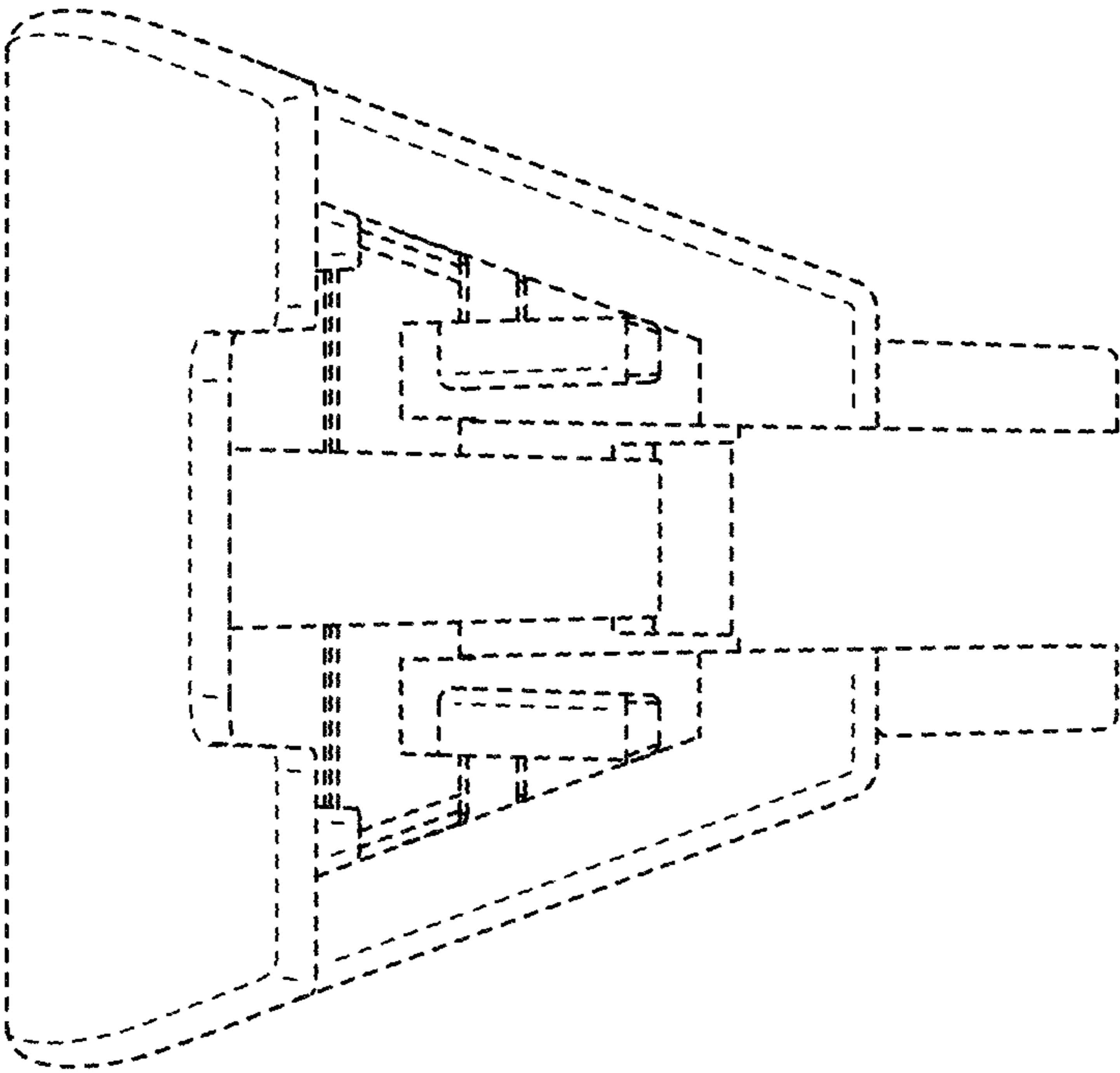

FIG. 6