



US00D836877S

(12) **United States Design Patent**
Mason

(10) **Patent No.:** **US D836,877 S**

(45) **Date of Patent:** **** Dec. 25, 2018**

(54) **GUIDING SURFACE RAIL**

(71) Applicant: **MASON PLASTICS CO.**, Winchester, TN (US)

(72) Inventor: **Russell W. Mason**, Winchester, TN (US)

(73) Assignee: **MASON PLASTICS CO.**, Winchester, TN (US)

(**) Term: **15 Years**

(21) Appl. No.: **29/537,761**

(22) Filed: **Aug. 28, 2015**

(51) **LOC (11) Cl.** **12-05**

(52) **U.S. Cl.**

USPC **D34/29; D25/41.1**

(58) **Field of Classification Search**

USPC D25/38.1, 41.1, 42, 43, 44, 119, 120, D25/121, 122, 126, 136; D34/28, 29; 52/152, 716.1; 256/59, 64, 65.01-65.03, 256/65.09, 65.11, 65.15, 65.16, 66

CPC .. B25G 1/04; F16B 7/105; E04F 11/18; E04F 11/1802; E04F 11/1818; E04F 11/1836

See application file for complete search history.

(56) **References Cited**

U.S. PATENT DOCUMENTS

D24,704 S * 9/1895 Dippo D25/122
909,027 A * 1/1909 Sanders F16L 9/06
138/173

(Continued)

OTHER PUBLICATIONS

<http://midwestchain.com/content/conveyor-guide-rails>, Available Aug. 18, 2014.*

(Continued)

Primary Examiner — Susan Bennett Hattan

Assistant Examiner — Leanne Was-Englehart

(74) *Attorney, Agent, or Firm* — Terry M. Sanks, Esq.;
Beusse Wolter Sanks & Maire, PLLC

(57) **CLAIM**

The ornamental design for a guiding surface rail.

DESCRIPTION

FIG. 1 is a perspective view of a guiding surface rail with a rounded surface;

FIG. 2 is a front view and back view of the guiding surface rail with the rounded surface;

FIG. 3 is a top view of the guiding surface rail with the rounded surface;

FIG. 4 is a bottom view of the guiding surface rail with the rounded surface;

FIG. 5 is a left view of the guiding surface rail with the rounded surface, the right view being a mirror image thereof;

FIG. 6 is a perspective view of a guiding surface rail with a rounded surface and an inverted pyramidal opening;

FIG. 7 is a front view and back view of the guiding surface rail with the rounded surface and the inverted pyramidal opening;

FIG. 8 is a top view of the guiding surface rail with the rounded surface and the inverted pyramidal opening;

FIG. 9 is a bottom view of the guiding surface rail with the rounded surface and the inverted pyramidal opening; and,

FIG. 10 is a left view of the guiding surface rail with the arcuate surface, the right view being a mirror image thereof.

The break lines depict the bounds of the Claim. The portion of the guiding surface rail between the break lines forms no part of the claimed design.

1 Claim, 2 Drawing Sheets

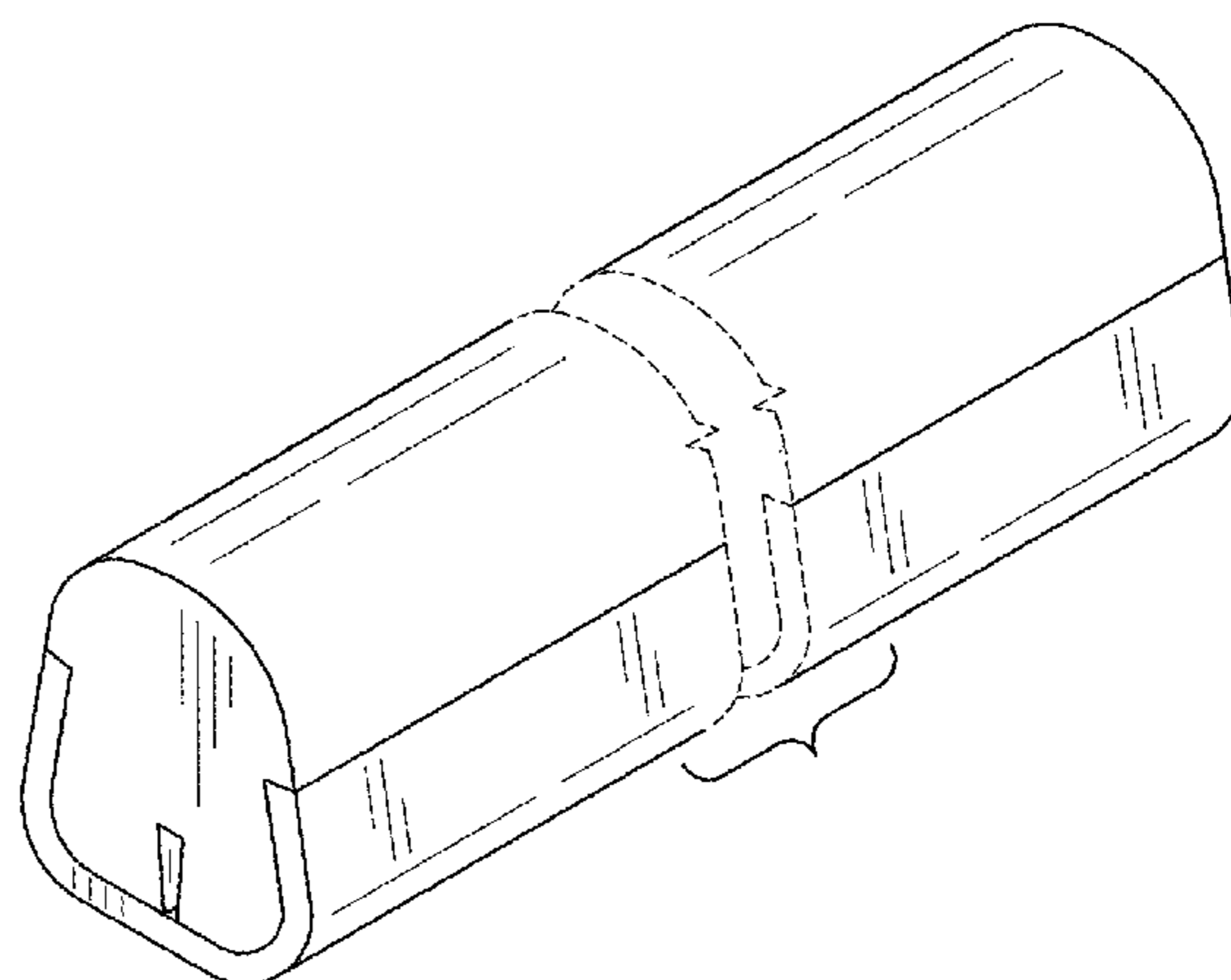
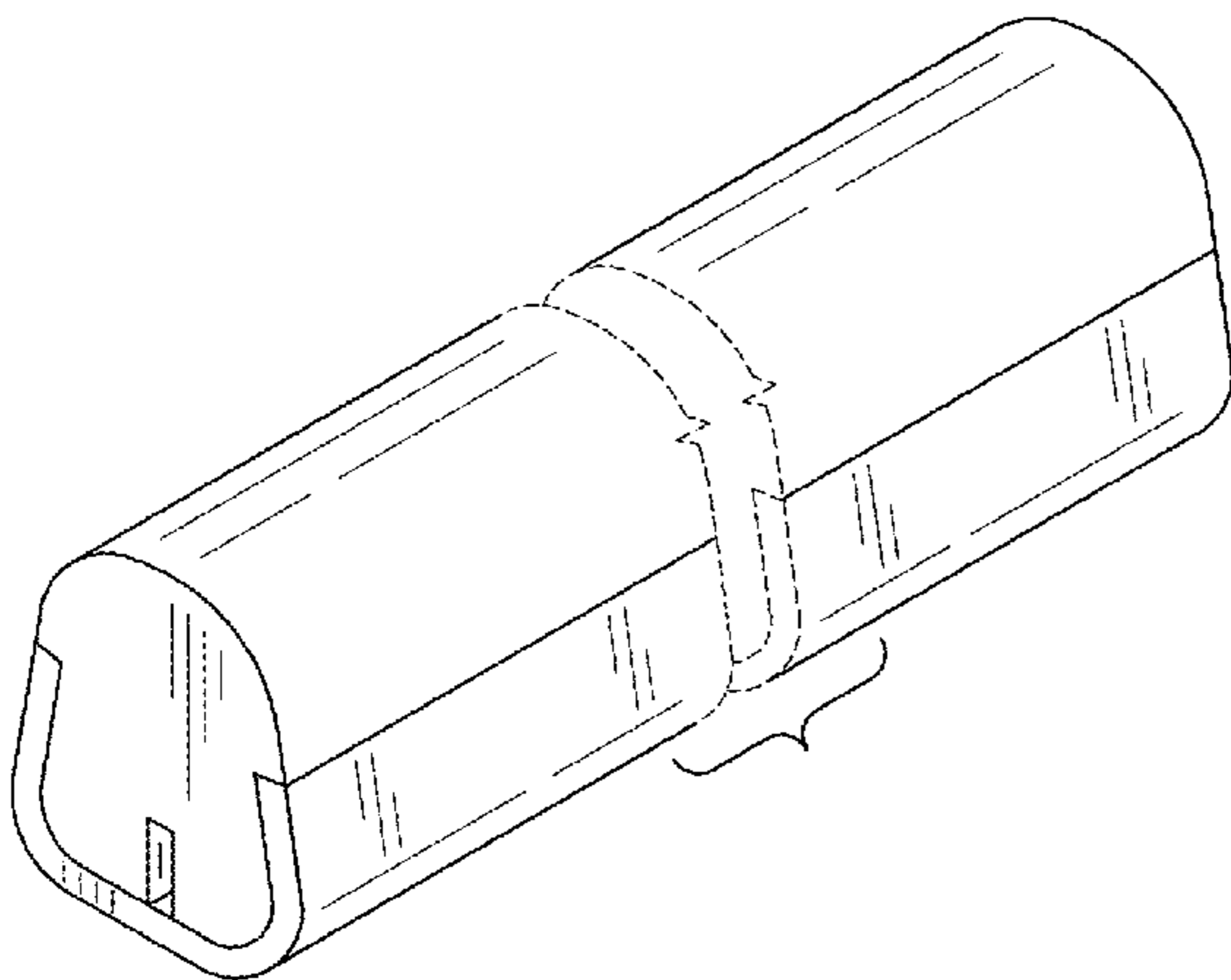

(56)

References Cited

U.S. PATENT DOCUMENTS

4,256,287 A * 3/1981 Birmingham E04F 11/1836
 144/348
 D328,187 S * 7/1992 Saurette 294/171
 D348,940 S * 7/1994 Clark D25/124
 D381,177 S * 7/1997 Patois D25/121
 D515,266 S * 2/2006 Moe D25/38.1
 D650,143 S * 12/2011 Bhosale D34/29
 D686,580 S * 7/2013 Woodlief D13/155
 D693,945 S * 11/2013 Cordovana D25/126
 D742,549 S * 11/2015 Ryan D25/122
 D755,988 S * 5/2016 Walker D25/119
 D757,240 S * 5/2016 Forlong D23/393
 D762,462 S * 8/2016 Anderson D25/121
 D765,008 S * 8/2016 Conrad D12/317
 D769,034 S * 10/2016 Lawson D6/681.1
 D769,463 S * 10/2016 Ho D25/122
 2016/0023347 A1 * 1/2016 Ho B25G 1/04
 16/429

OTHER PUBLICATIONS

<https://www.masonplastics.com/MasonPlastics-Part-Catalog.pdf>,
 Retrieved Jan. 23, 2017.*
<http://masonplastics.com/S-lubricated-rails.htm>, Available Oct. 14,
 2013.*
<https://www.masonplastics.com/static-dissipative-guide-rails.htm>, Avail-
 able Oct. 14, 2013.*

* cited by examiner

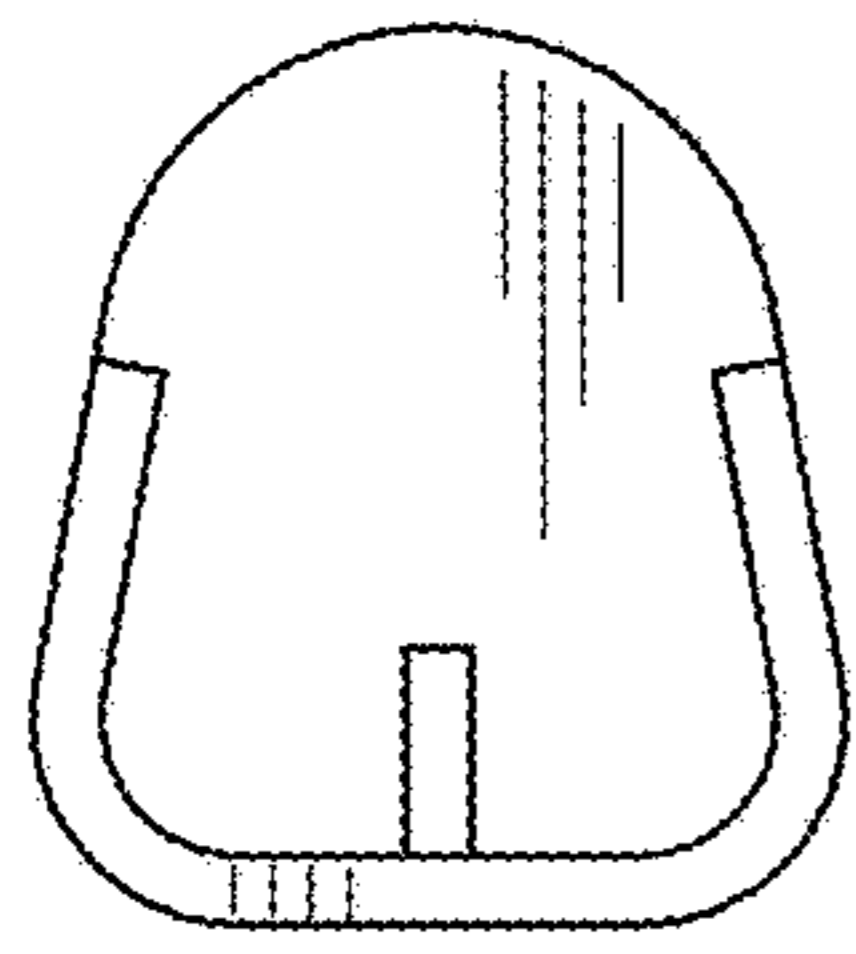

FIG. 2

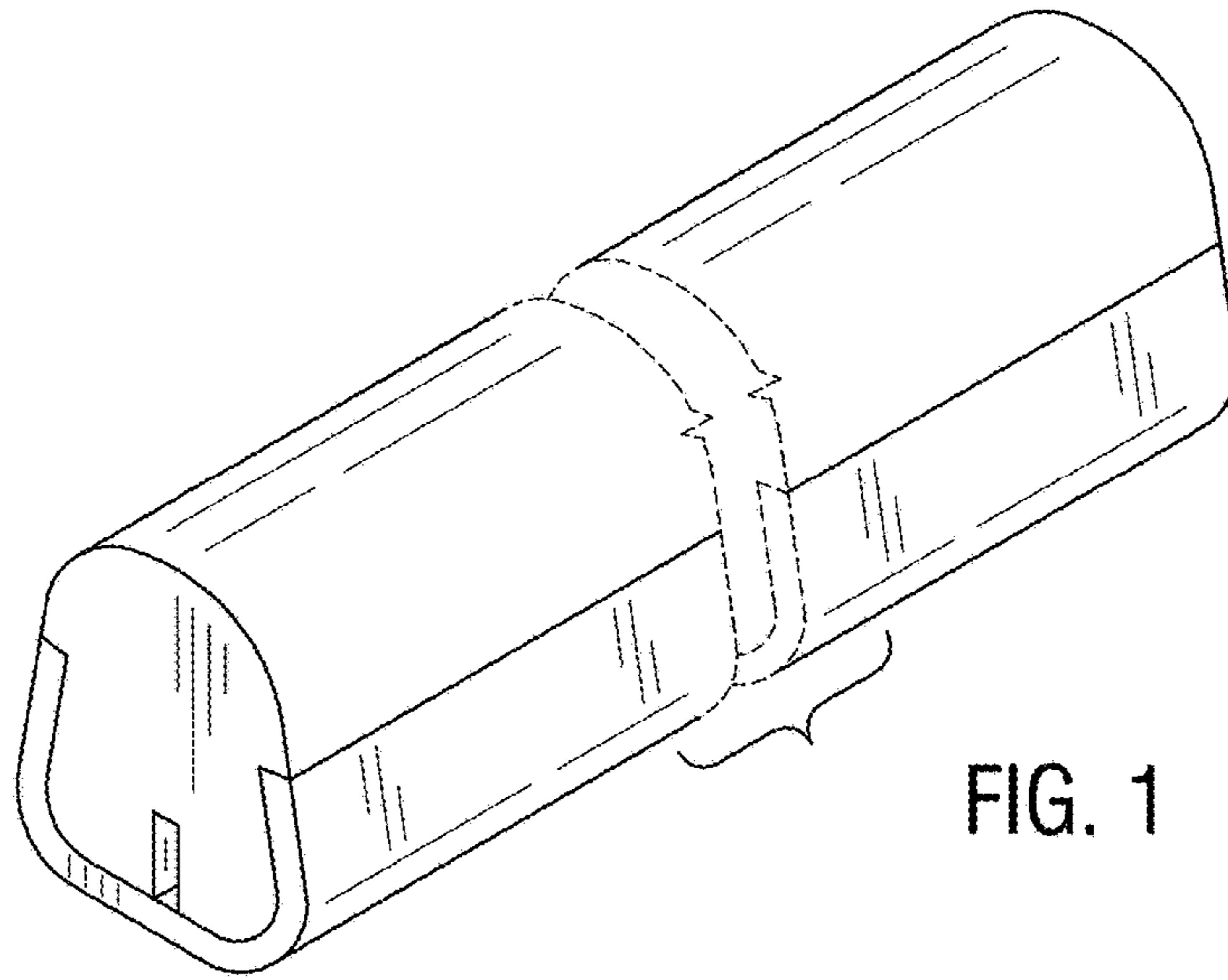

FIG. 1

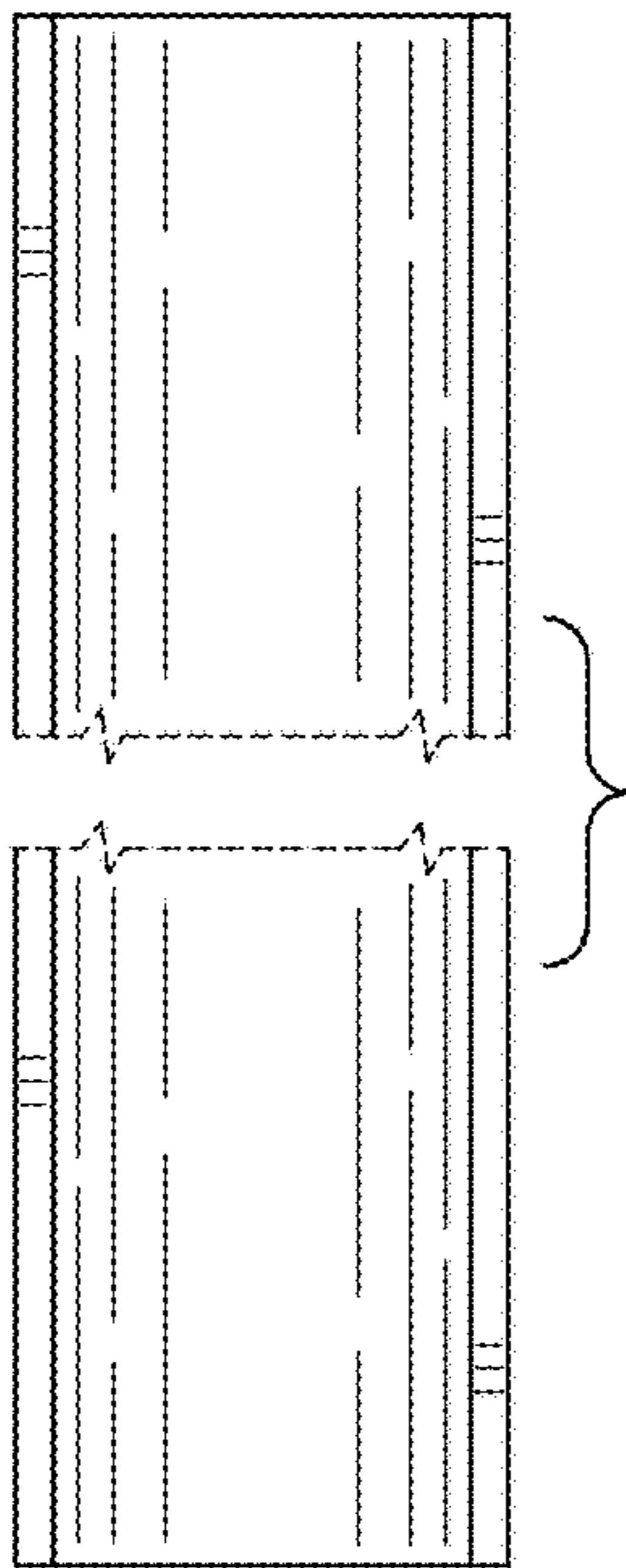

FIG. 3

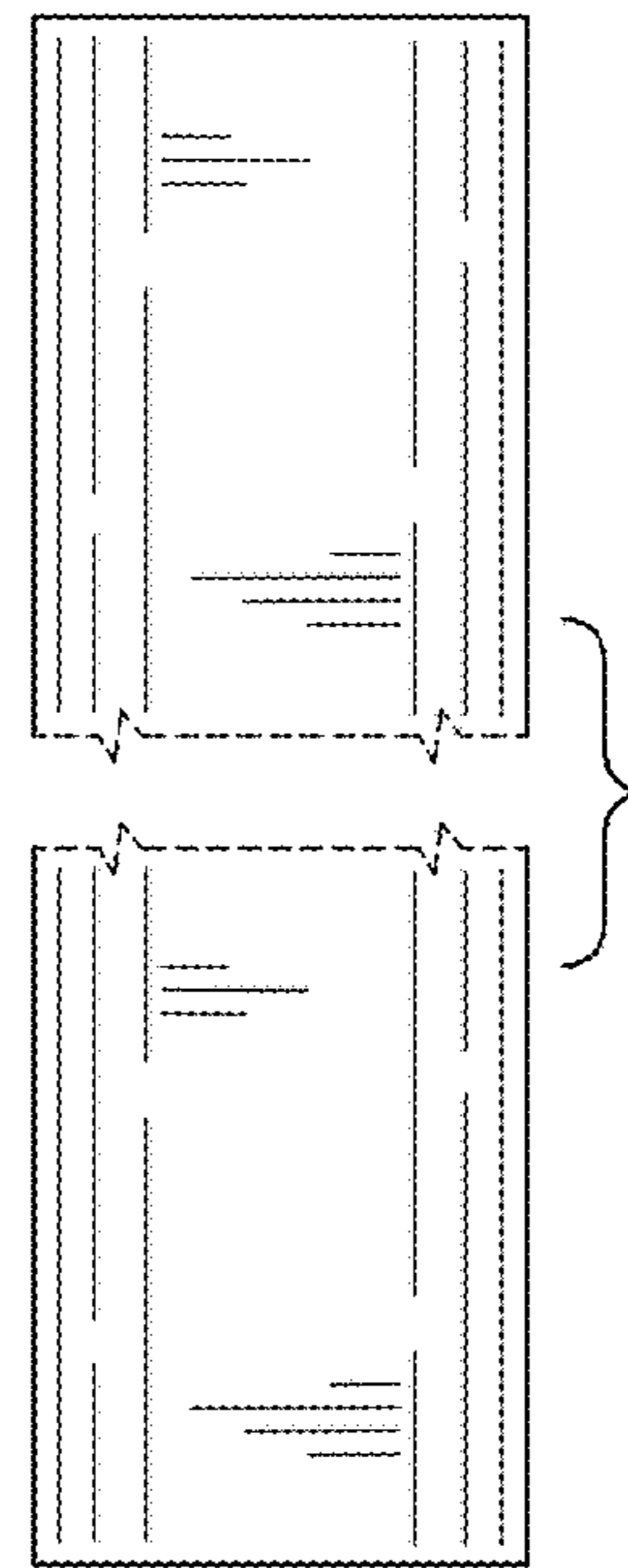

FIG. 4

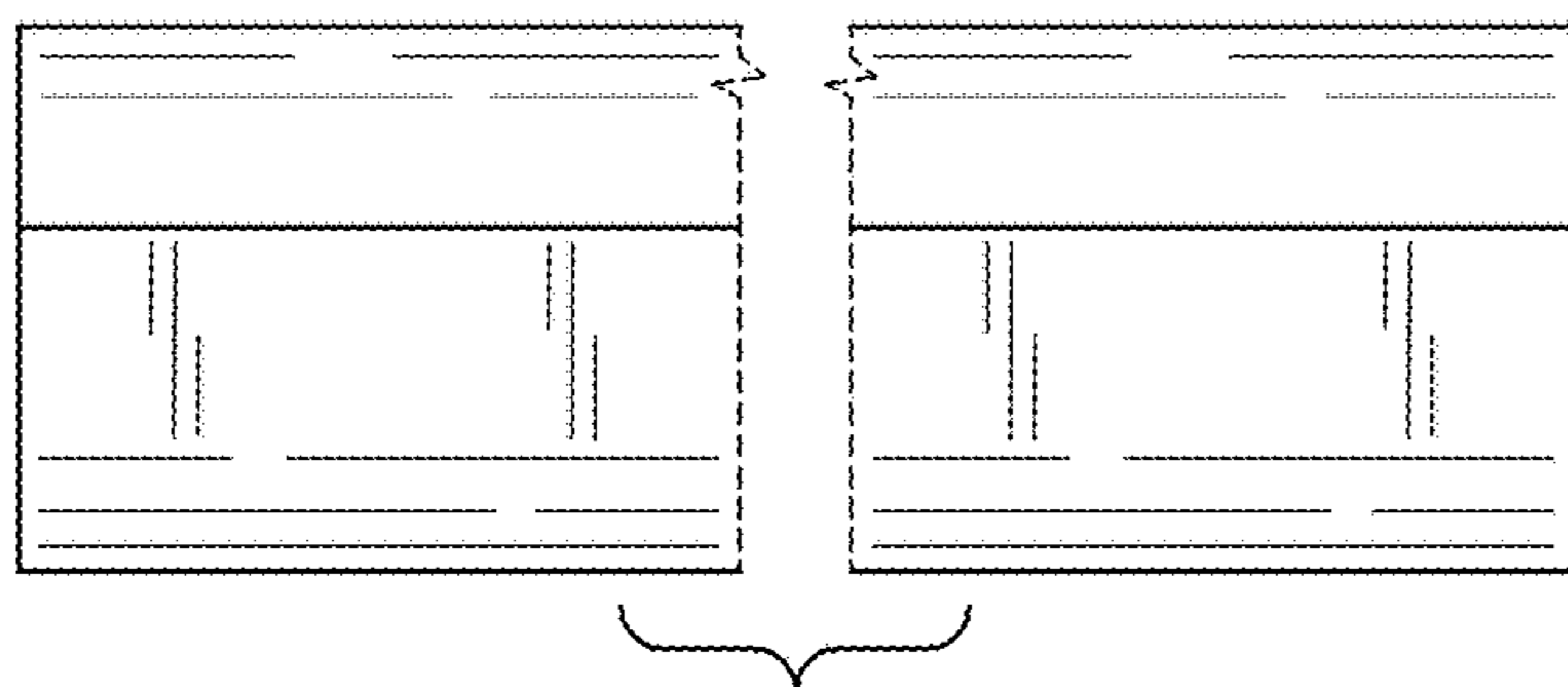

FIG. 5

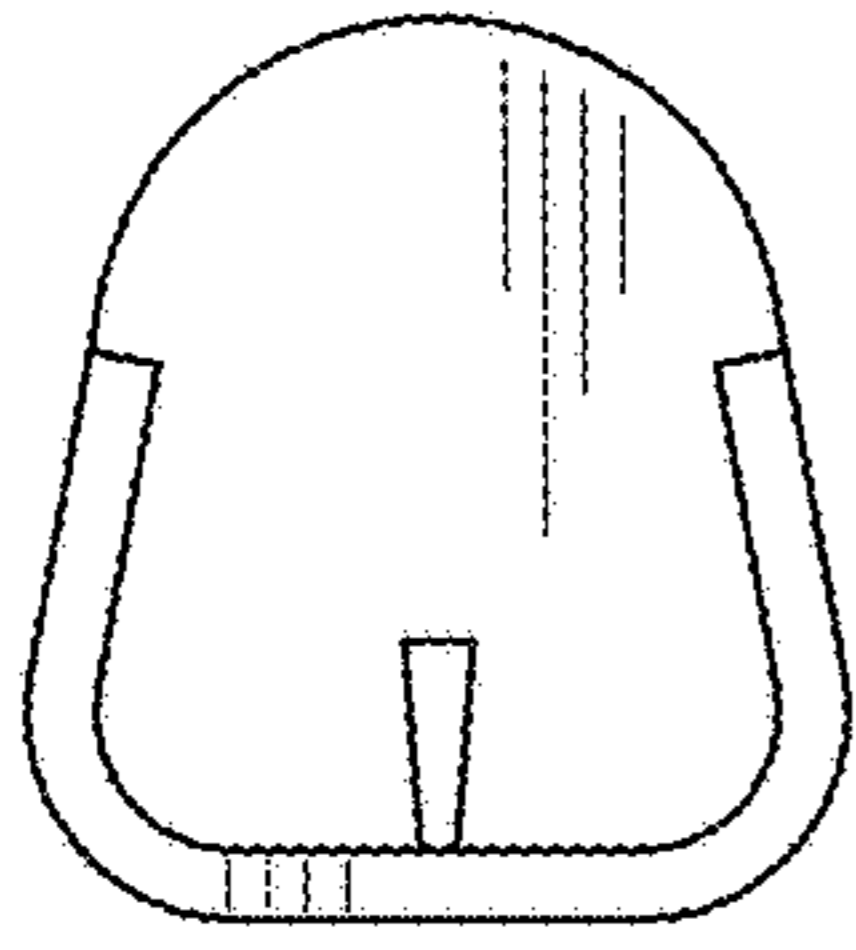

FIG. 7

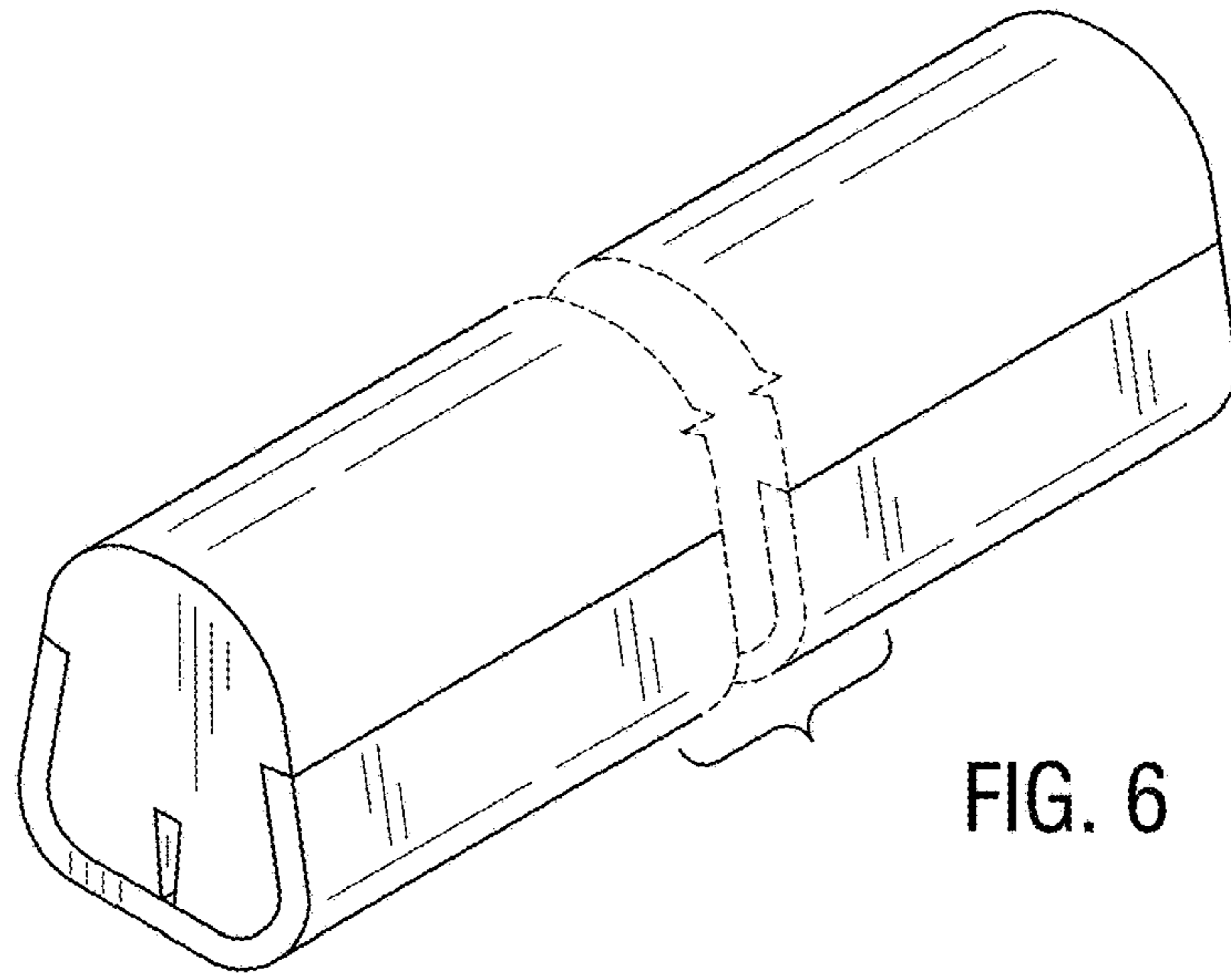

FIG. 6

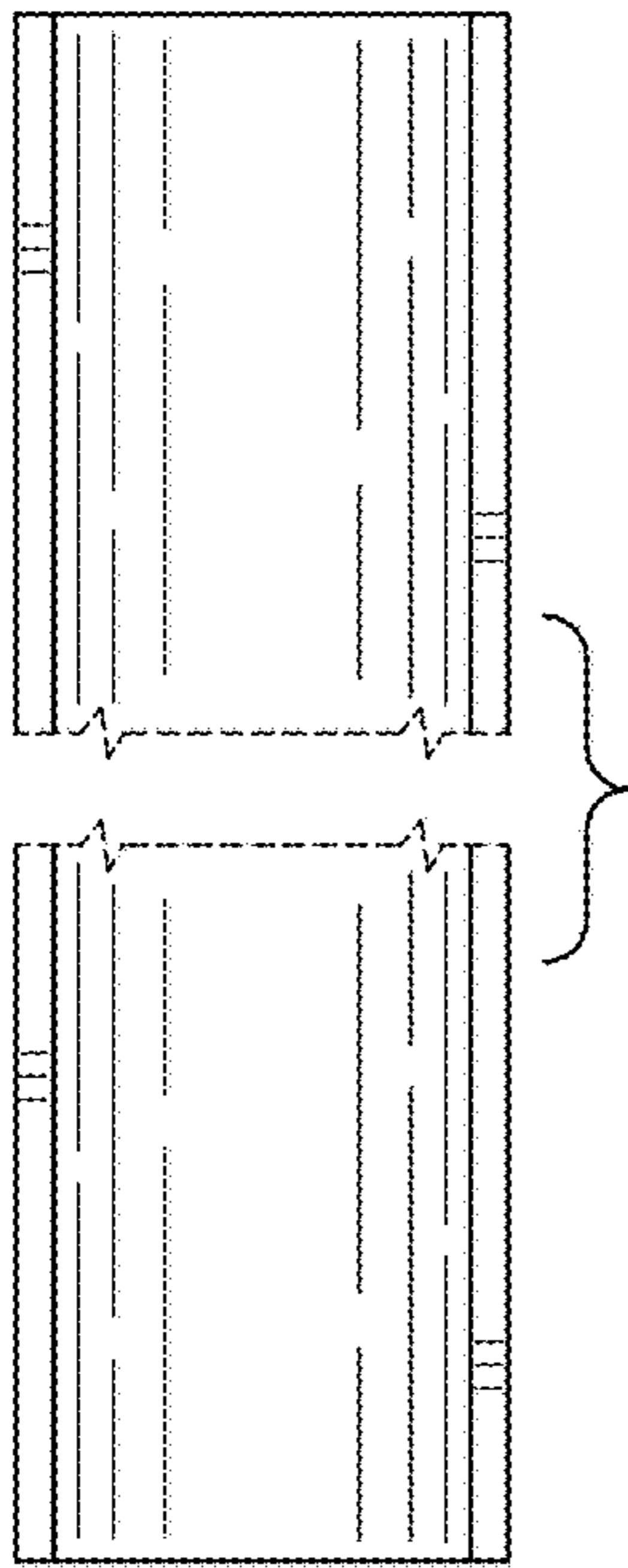

FIG. 8

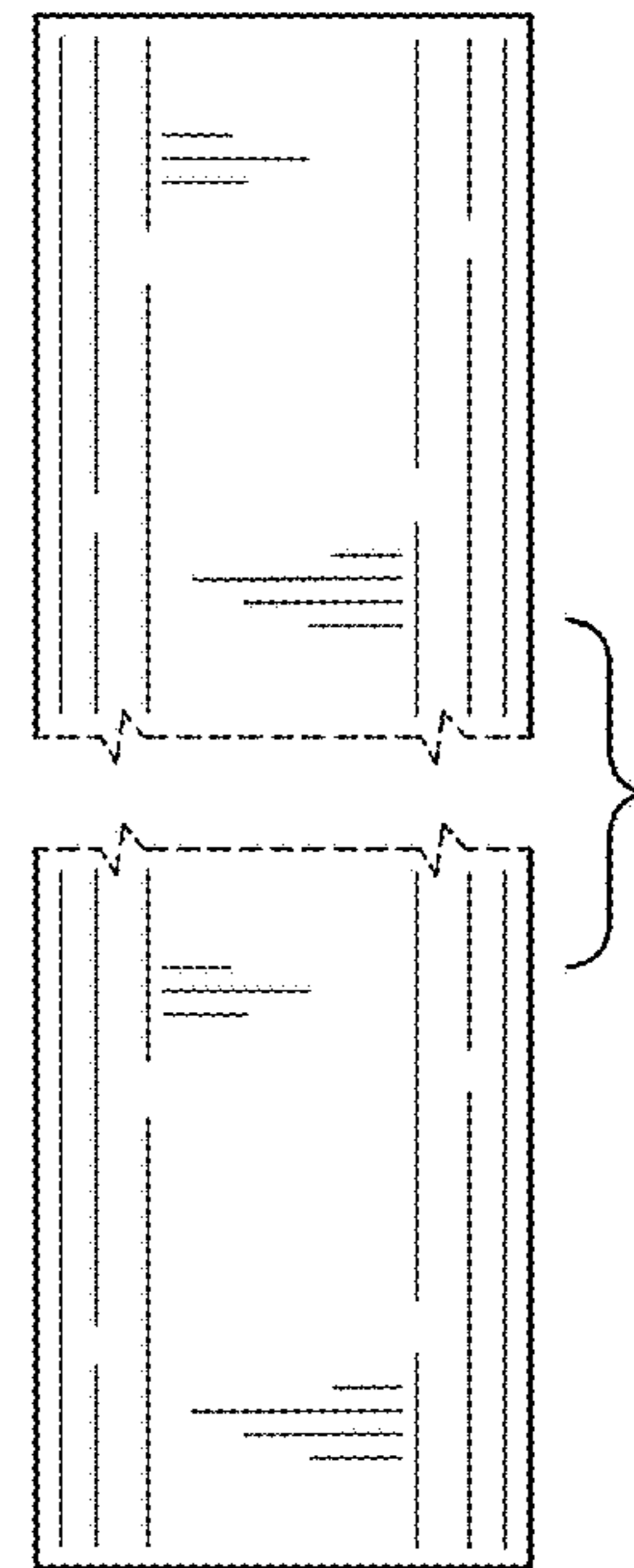

FIG. 9

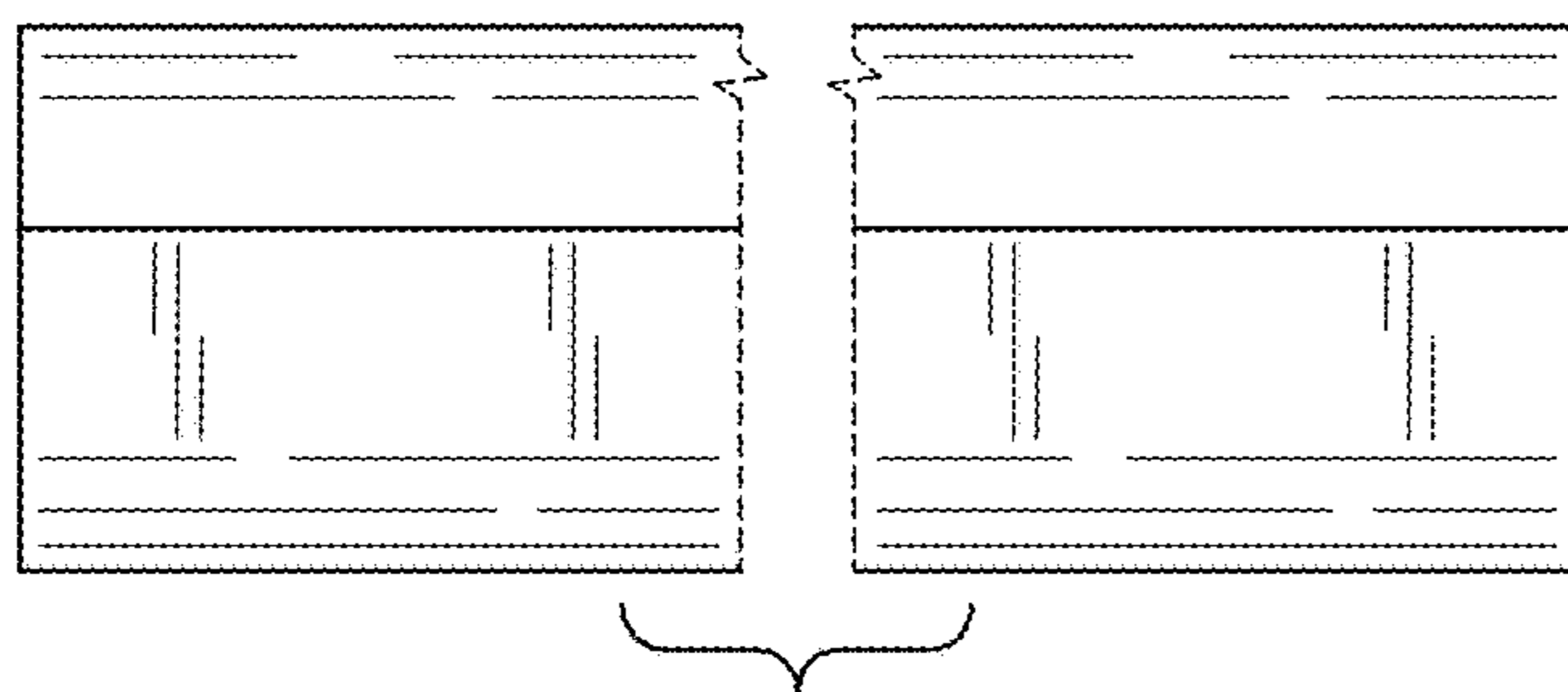

FIG. 10