



US00D836491S

(12) **United States Design Patent** (10) **Patent No.:** **US D836,491 S**
Elbaz (45) **Date of Patent:** **** *Dec. 25, 2018**

(54) **MOBILE RETAIL TRUCK**
(71) Applicant: **Stephan Elbaz**, Hoboken, NJ (US)
(72) Inventor: **Stephan Elbaz**, Hoboken, NJ (US)
(*) Notice: This patent is subject to a terminal disclaimer.
(**) Term: **15 Years**
(21) Appl. No.: **29/547,594**
(22) Filed: **Dec. 4, 2015**
(51) **LOC (11) Cl.** **12-08**
(52) **U.S. Cl.**
USPC **D12/93**
(58) **Field of Classification Search**
USPC D12/93, 96, 99, 94, 106; 180/89.13;
296/22, 24.3, 24.36; 52/204.1, 204.5,
52/204.51; D25/48.7, 47.1; D20/29;
D7/405
CPC B60P 1/00; B60P 3/00
See application file for complete search history.

(56) **References Cited**
U.S. PATENT DOCUMENTS
D120,666 S 5/1940 Edwards
D153,466 S 4/1949 Stevens
D249,494 S 9/1978 Lambitz et al.
6,585,305 B2* 7/2003 Nazginov B60P 3/0255
296/21
D485,800 S 1/2004 Smith
D494,921 S 8/2004 Taylor
D504,384 S 4/2005 Straschewski
D551,128 S 9/2007 Renard
D652,353 S * 1/2012 Cohen D12/93
D654,314 S * 2/2012 Benold D7/405
D701,471 S * 3/2014 Cohen D12/93

D706,453 S * 6/2014 Kalkhoven D25/48.7
D707,852 S * 6/2014 Maringer D25/48.7
D719,679 S * 12/2014 Diether D25/48.7
D736,675 S 8/2015 Cohen et al.
D779,876 S * 2/2017 Chung D7/405
2013/0175819 A1* 7/2013 Hindle B60P 3/00
296/24.3

* cited by examiner
Primary Examiner — Daniel D Bui
Assistant Examiner — Andrew Kerr
(74) *Attorney, Agent, or Firm* — Gearhart Law LLC

(57) **CLAIM**
The ornamental design for a mobile retail truck, as shown and described.

DESCRIPTION
FIG. 1 is a front and left perspective view of a mobile retail truck, showing my new invention.
FIG. 2 is a rear and left side perspective view thereof;
FIG. 3 is a left side elevation view thereof;
FIG. 4 is a rear elevation view thereof;
FIG. 5 is a front and right side perspective thereof;
FIG. 6 is a rear and right side perspective thereof;
FIG. 7 is a right side elevation view thereof;
FIG. 8 is an enlarged cross-sectional view thereof taken about line 8-8 in FIG. 3;
FIG. 9 is an enlarged partial rear facing interior perspective view thereof; and,
FIG. 10 is another enlarged partial rear facing interior perspective view thereof.
The even-spaced broken lines in the drawing views represent environmental structure and form no part of the claimed design. The dash-dot broken lines in the drawing views define the bounds of the claimed design and form no part thereof.

1 Claim, 10 Drawing Sheets

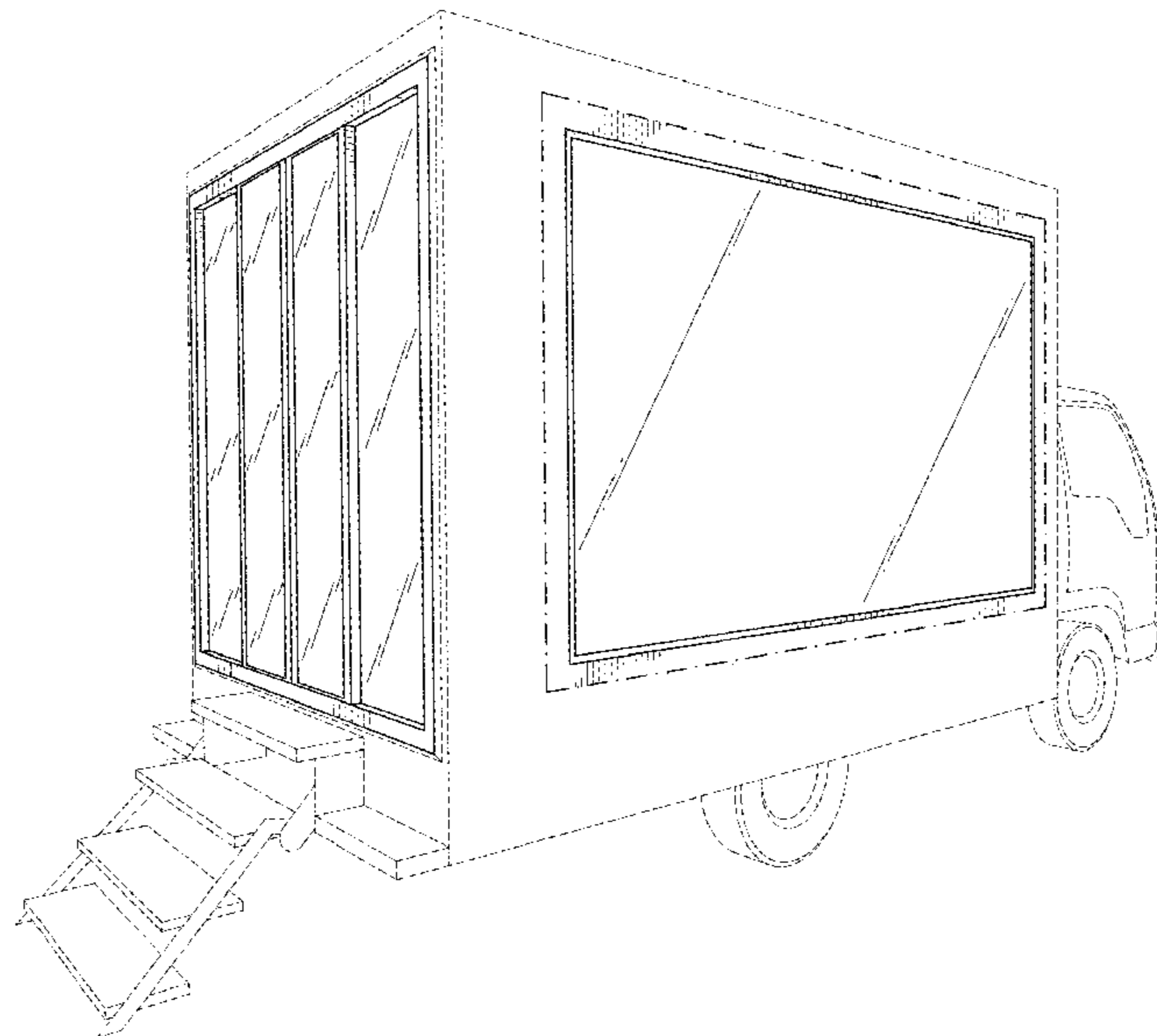

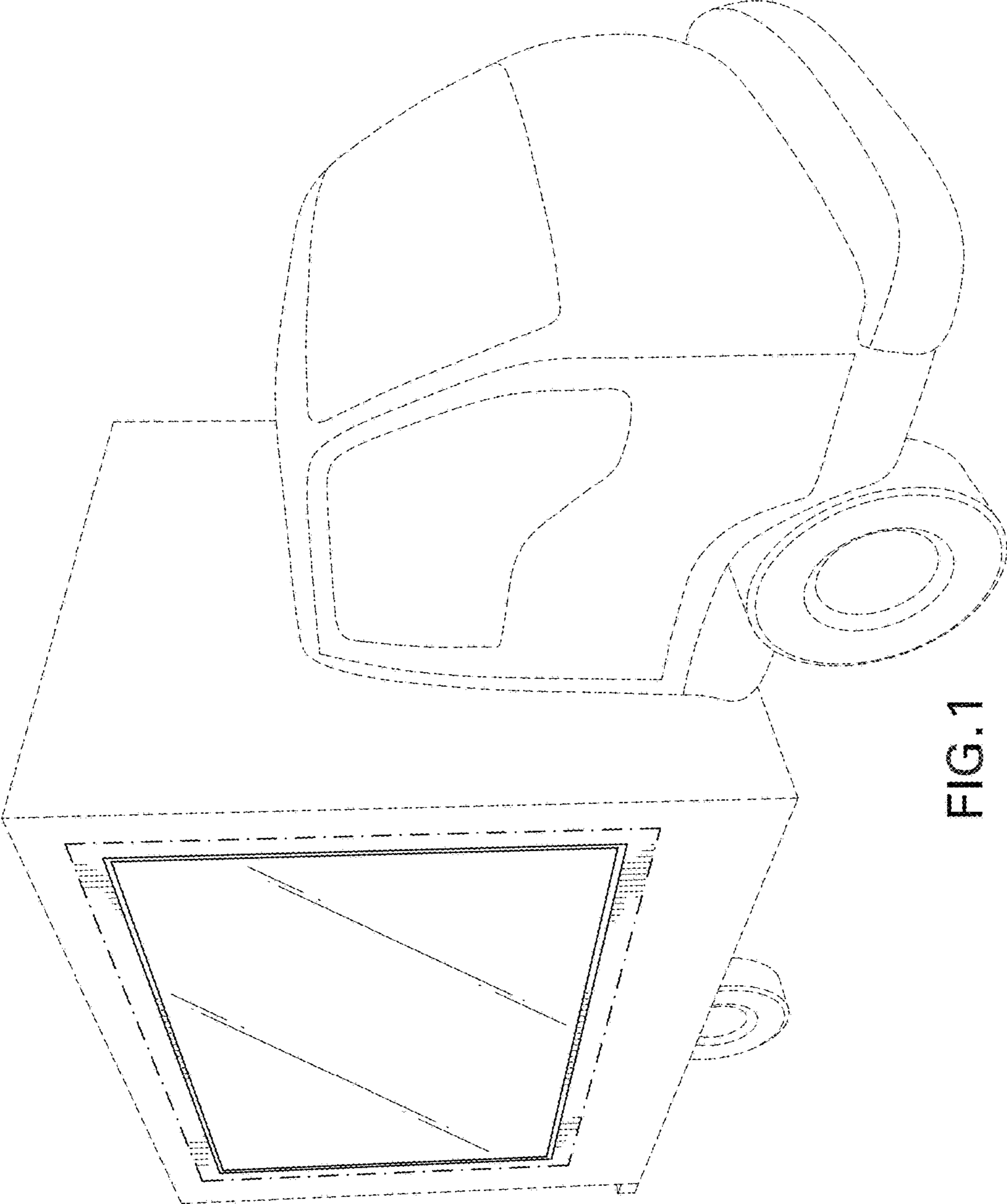

FIG. 1

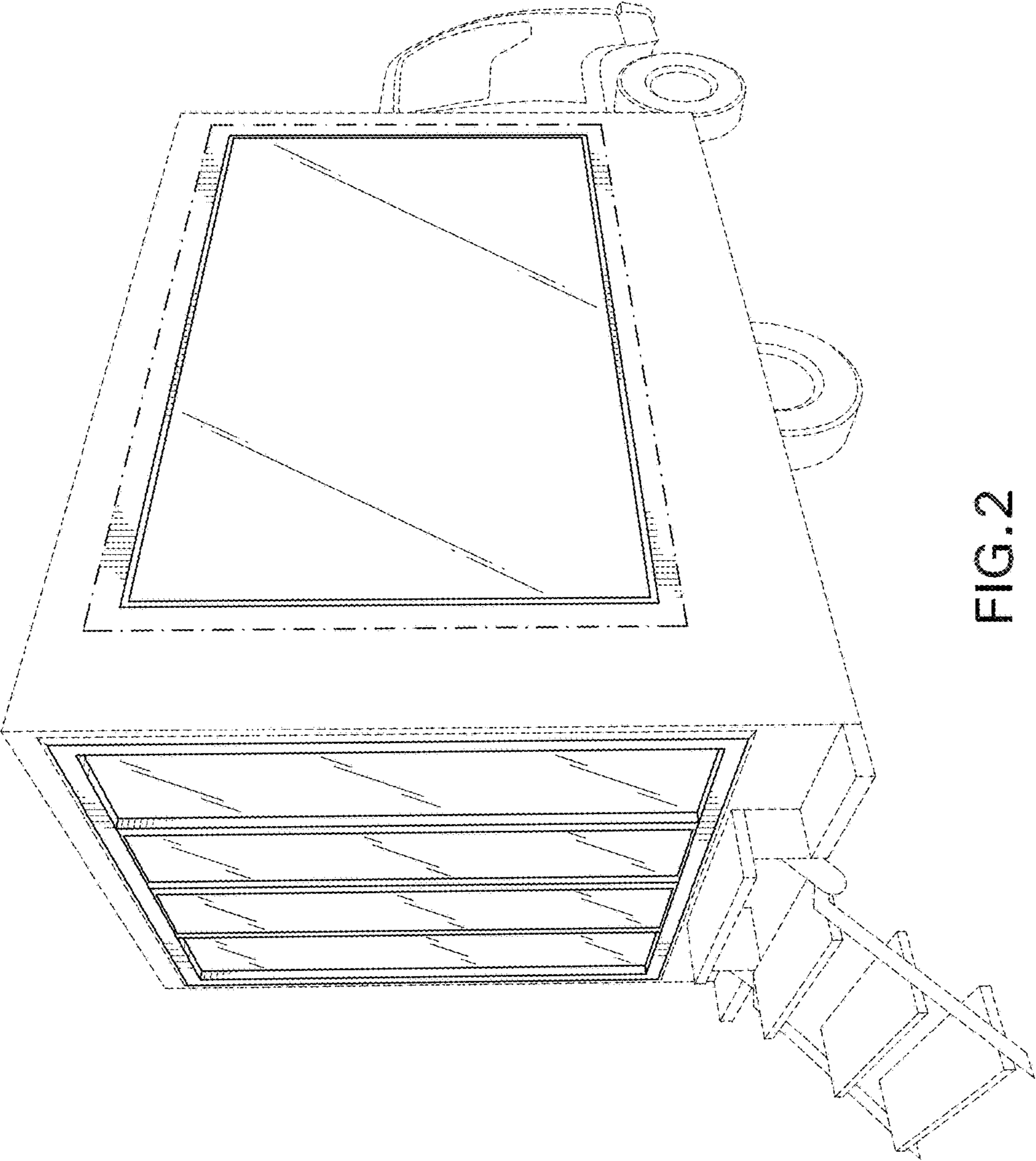

FIG.2

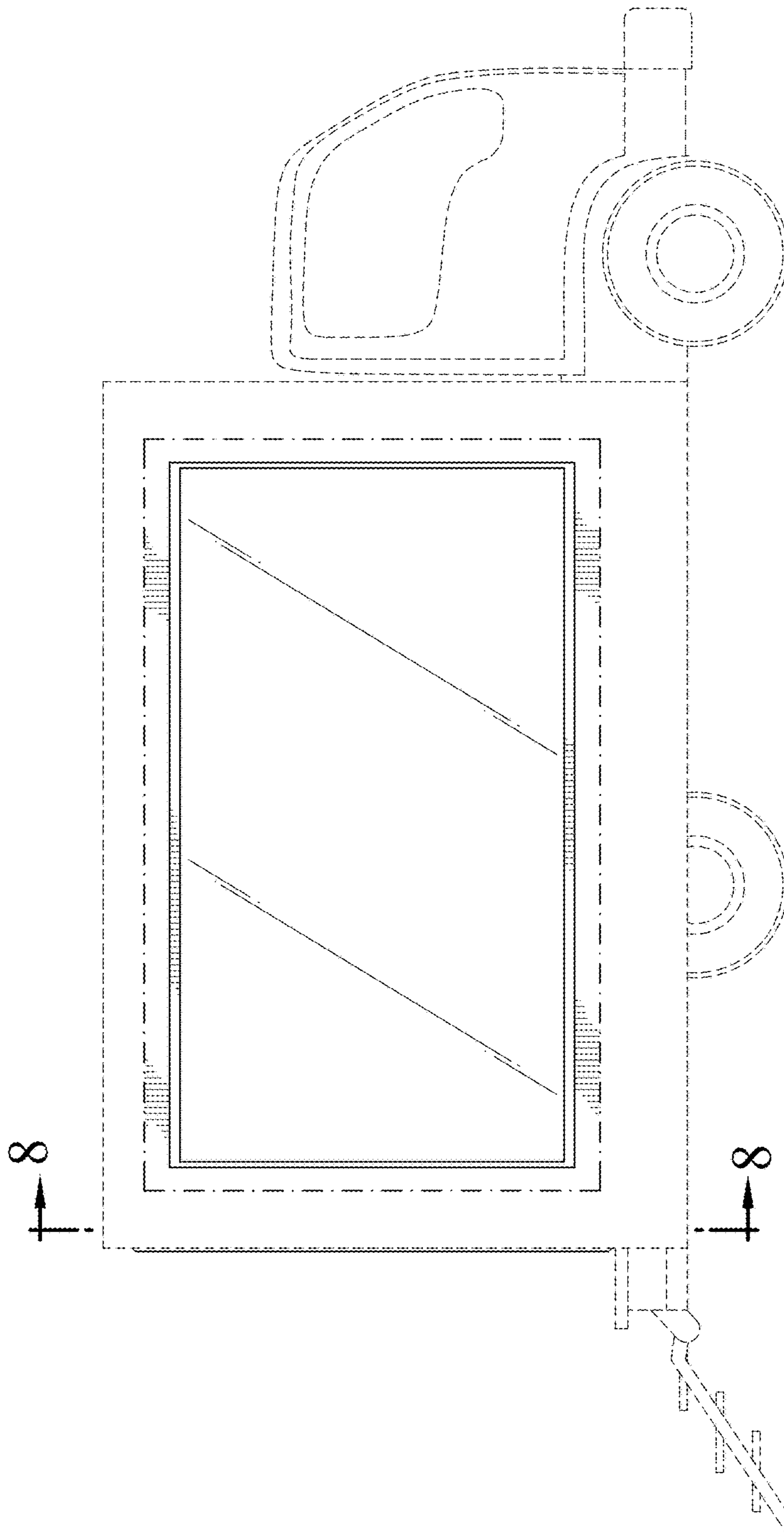

FIG.3

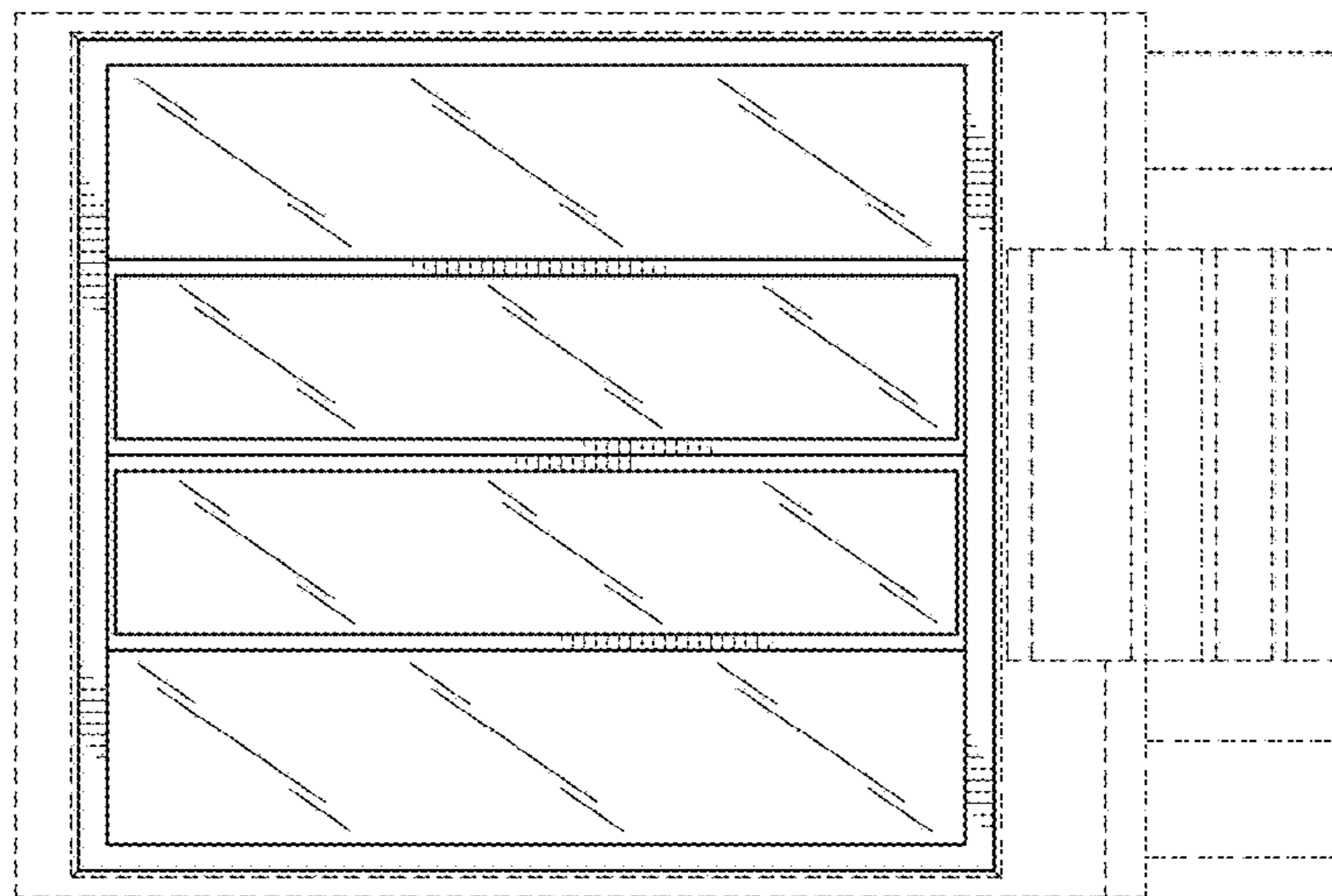

FIG.4

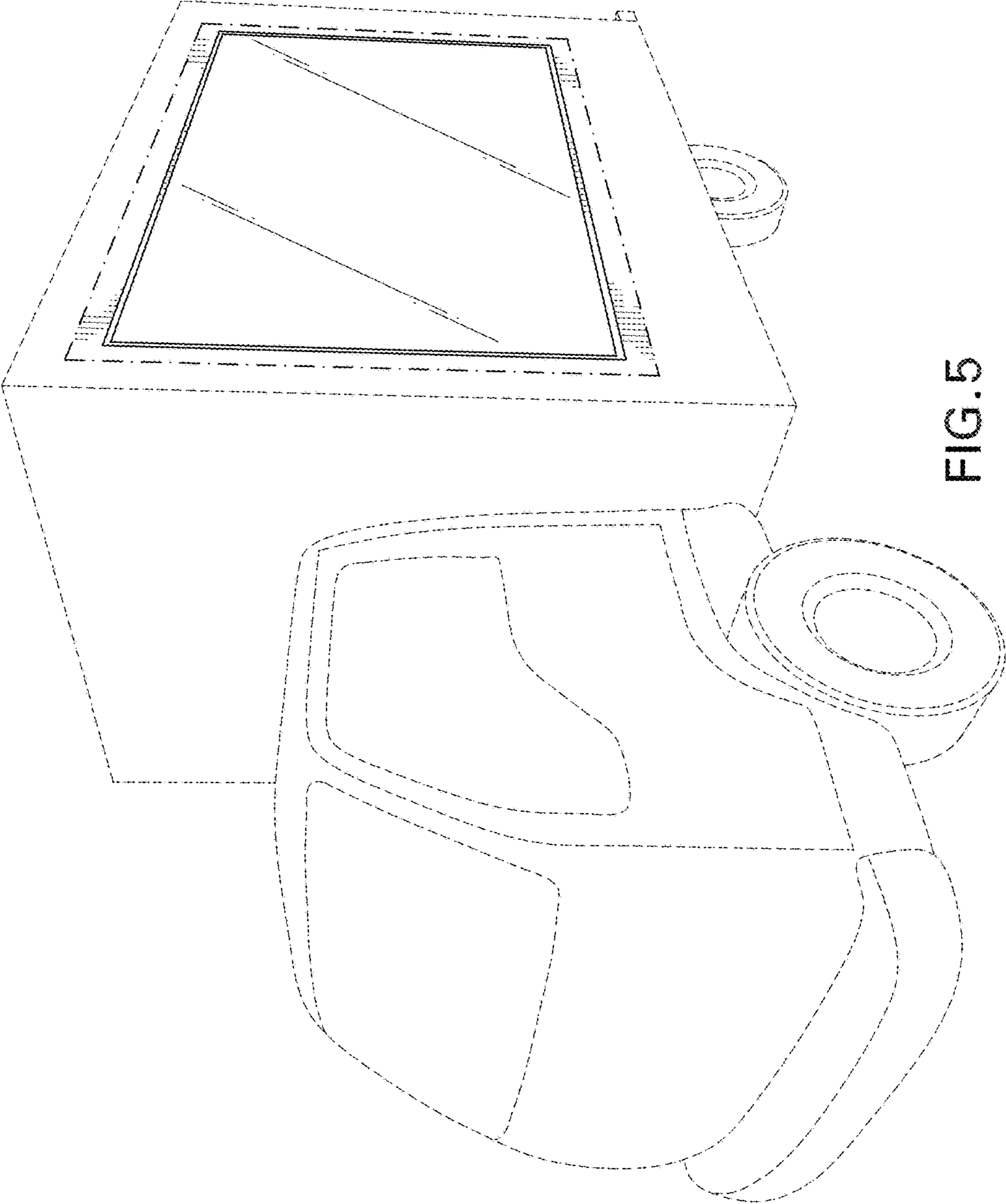

FIG. 5

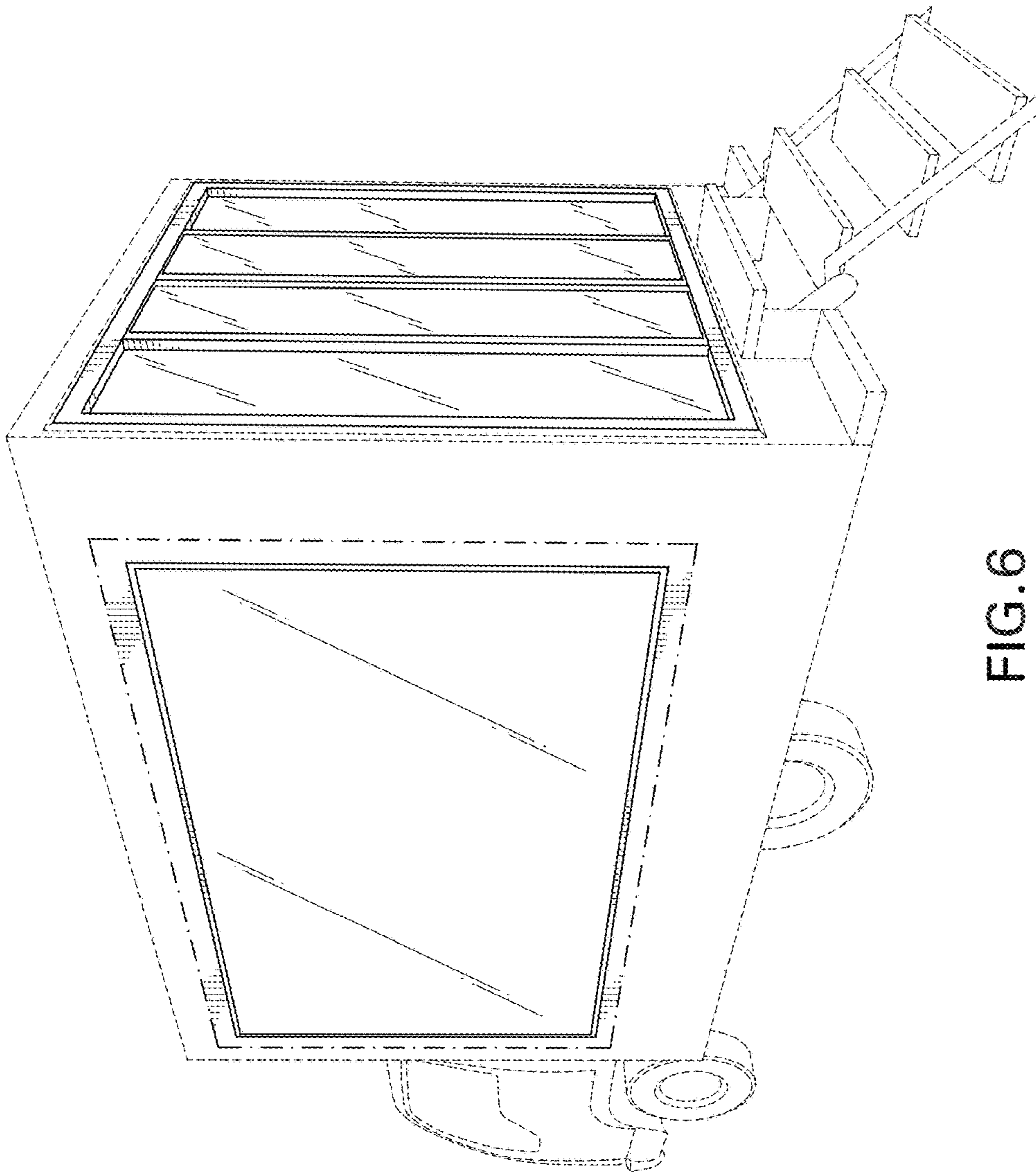

FIG.6

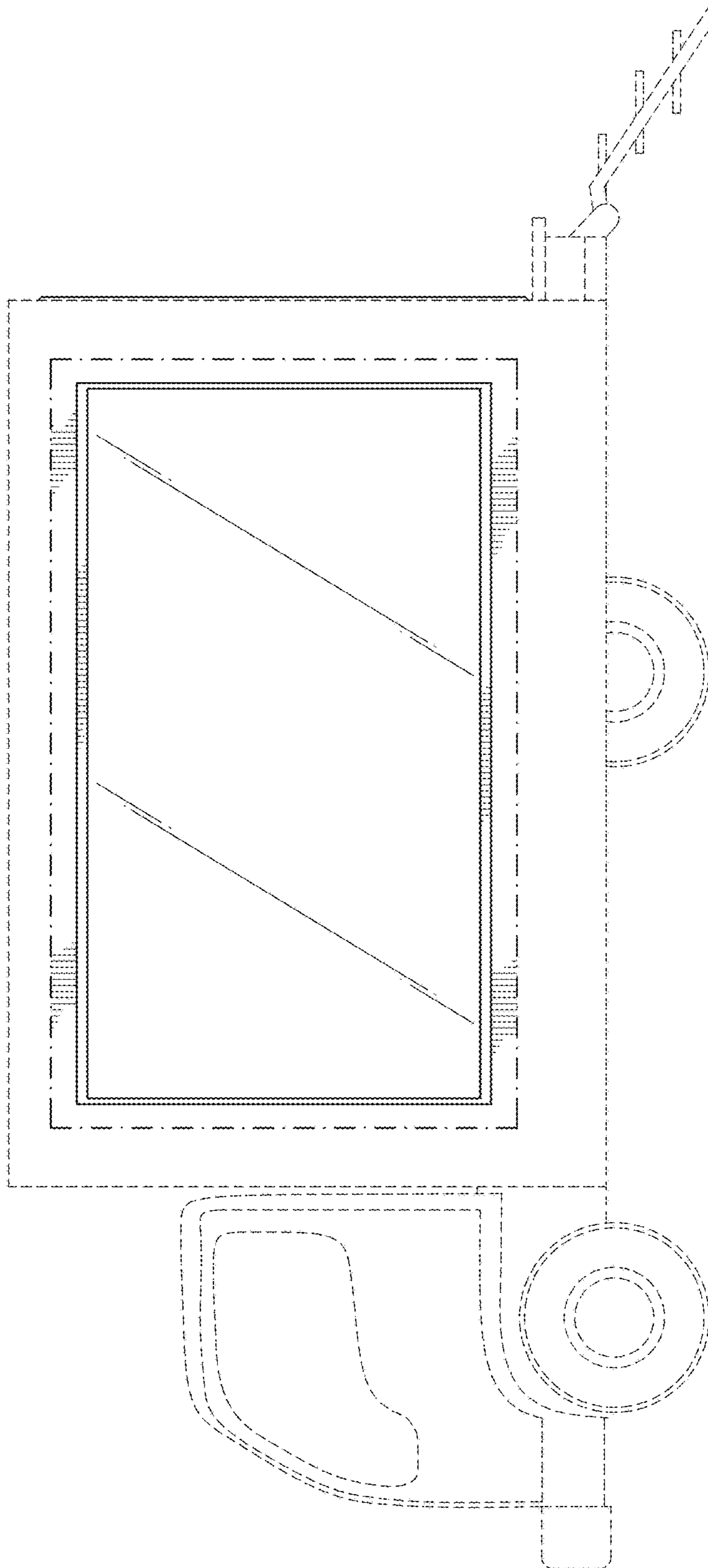

FIG. 7

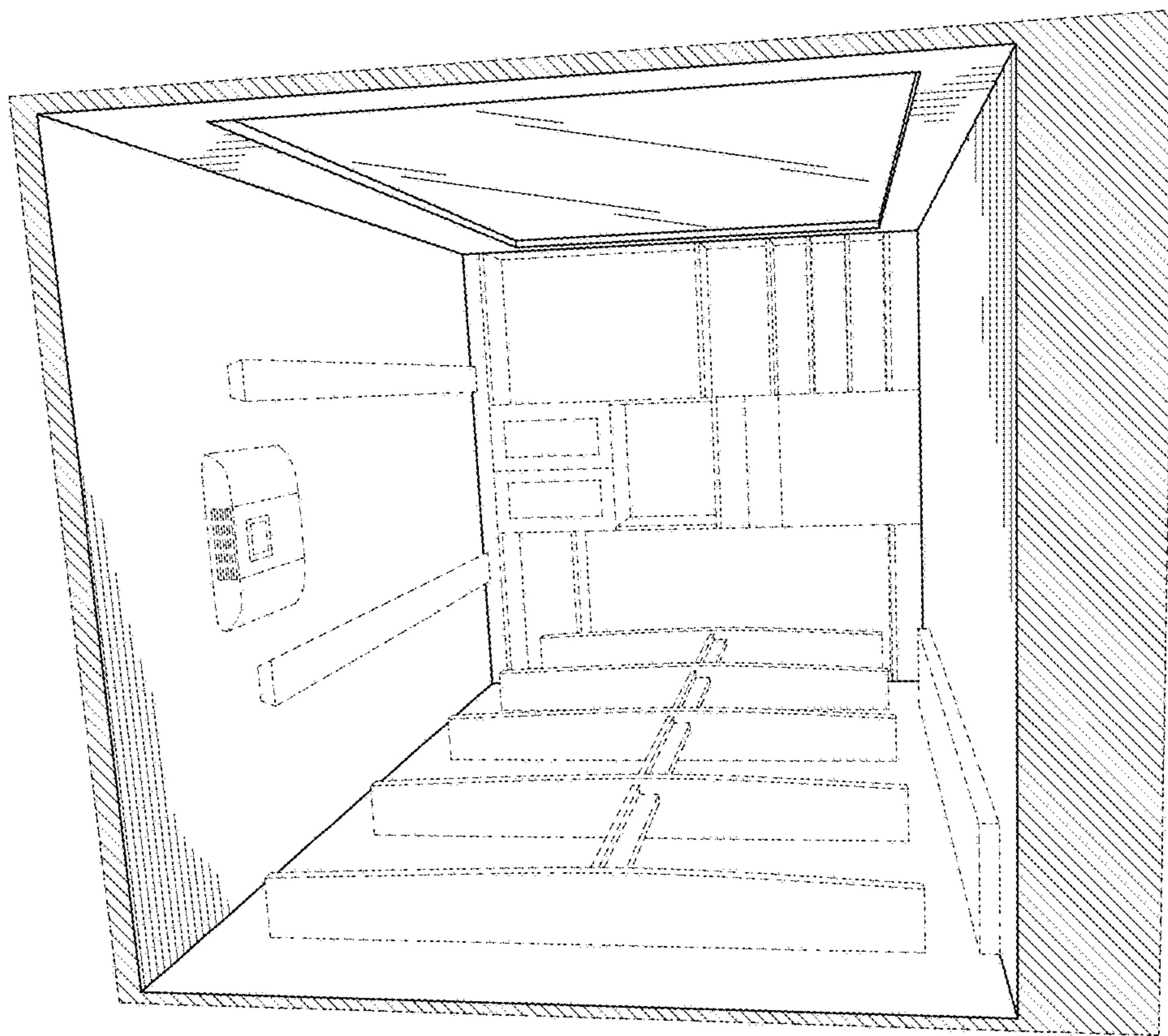

FIG. 8

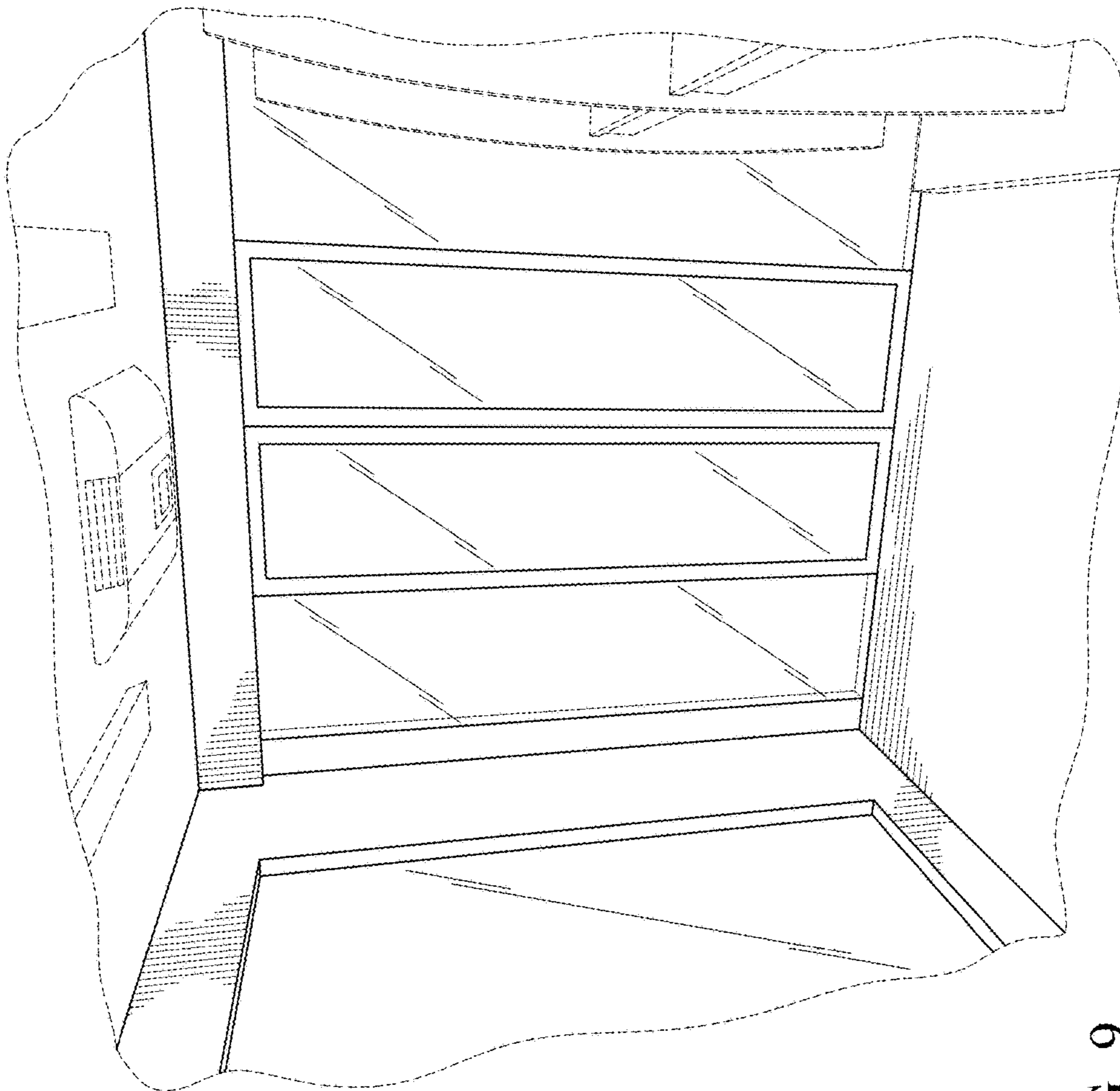

FIG. 9

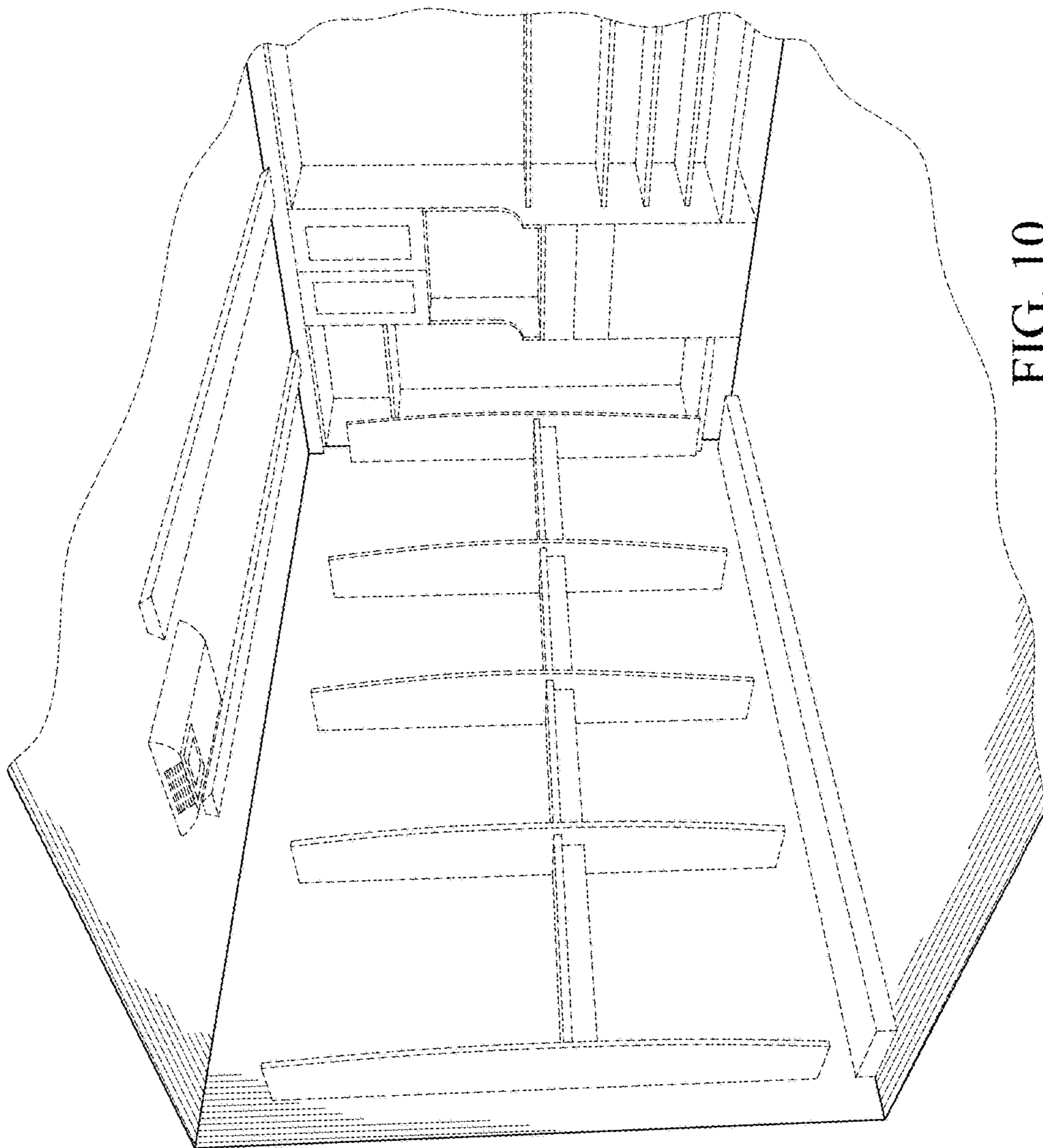

FIG. 10