



US00D836216S

(12) **United States Design Patent**
Roberts

(10) **Patent No.:** **US D836,216 S**

(45) **Date of Patent:** **** Dec. 18, 2018**

(54) **WINDOW SASH EXTRUSION**

(71) Applicant: **VEKA, INC.**, Fombell, PA (US)

(72) Inventor: **William G. Roberts**, Beaver Falls, PA (US)

(73) Assignee: **VEKA, INC.**, Fombell, PA (US)

(**) Term: **15 Years**

(21) Appl. No.: **29/574,483**

(22) Filed: **Aug. 16, 2016**

Related U.S. Application Data

(62) Division of application No. 29/528,808, filed on Jun. 1, 2015, now Pat. No. Des. 769,467.

(51) **LOC (11) Cl.** **25-01**

(52) **U.S. Cl.**
USPC **D25/124**

(58) **Field of Classification Search**

USPC D25/35, 38.1, 41.1, 47.1, 48.2, 48.3,
D25/48.4, 55, 119-137, 164, 199;
D8/349, 353, 354, 355, 363, 373, 376,
D8/380, 381, 382, 403; D6/324, 327,
D6/648.1, 653.11, 654.11, 702, 712,
D6/718.12, 512, 554, 556; D21/484-506
CPC ... E04C 3/00; E04C 3/005; E04C 3/02; E04C
3/04; E04C 3/12; E04C 3/20; E04C 3/28;
E04C 3/30; E06B 1/00; E06B 1/006;
E06B

(Continued)

(56) **References Cited**

U.S. PATENT DOCUMENTS

D364,472 S * 11/1995 Goss, Jr. D25/124
D364,690 S * 11/1995 Goss, Jr. D25/124

(Continued)

Primary Examiner — Cynthia Ramirez

Assistant Examiner — L. Martinez

(74) *Attorney, Agent, or Firm* — Eckert Seamans Cherin & Mellott, LLC; Arnold B. Silverman

(57) **CLAIM**

The ornamental design for a window sash extrusion, as shown and described.

DESCRIPTION

FIG. 1 is a top front isometric view showing my new design. FIG. 2 is a rear elevations view of the window sash extrusion of FIG. 1.

FIG. 3 is a front elevational view of the window sash extrusion of FIG. 1.

FIG. 4 is a top plan view of the window sash extrusion of FIG. 1.

FIG. 5 is a bottom plan view of the window sash extrusion of FIG. 1.

FIG. 6 is a right side elevational view of the window sash extrusion of FIG. 1.

FIG. 7 is a left side elevational view of the window sash extrusion of FIG. 1.

FIG. 8 is a top front isometric view another embodiment of my window sash extrusion design.

FIG. 9 is a front elevation view of the window sash extrusion of FIG. 8.

FIG. 10 is a rear elevational view of the window sash extrusion of FIG. 8.

FIG. 11 is a top plan view of the window sash extrusion of FIG. 8.

FIG. 12 is a bottom plan view of the window sash extrusion of FIG. 8.

FIG. 13 is a right side elevational view of the window sash extrusion of FIG. 8; and,

FIG. 14 is a left side elevational view of the window sash extrusion of FIG. 8.

The window sash extrusion is shown with a symbolic break in its length. The appearance of any portion of window sash extrusion between the break lines forms no part of the claimed design.

1 Claim, 8 Drawing Sheets

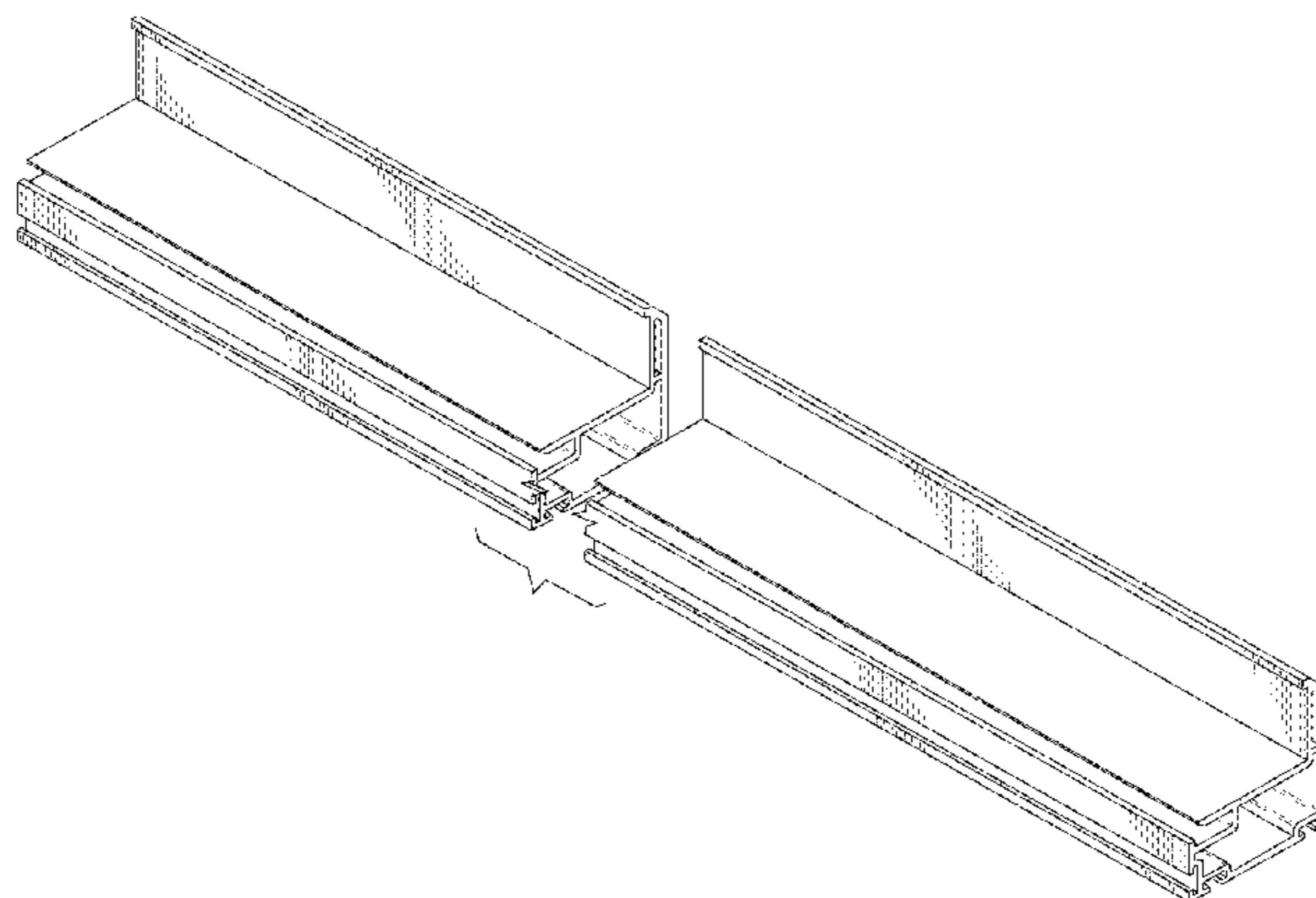

(58) **Field of Classification Search**

CPC 1/02; E06B 1/04; E06B 1/045; E06B 1/06;
 E06B 1/12; E06B 1/16; E06B 1/26; E06B
 1/30; E06B 1/32; E06B 1/325; E06B
 1/34; E06B 1/342; E06B 1/345; E06B
 1/347; E06B 1/36; E06B 1/363; E06B
 1/366; E06B 1/38; E06B 1/40; E06B
 1/52; E06B 1/522; E06B 1/524; E06B
 1/526; E06B 1/528; E06B 1/56; E06B
 1/60; E06B 1/6092; E06B 1/62; E06B
 1/70; E06B 1/702; E06B 1/705; E06B
 1/707; E04B 2/00; E04B 2/74; E04B
 2/76; E04B 2/761; E04B 2/762; E04B
 2/763; E04B 2/764; E04B 2/765; E04B
 2/7854; E04B 2/7863; E04B 2/7872;
 E04B 2/7881; E04B 2/789; E04B
 2001/2436; E04B 2001/2439; E04B
 2001/2442; E04B 2001/2445; E04B
 2001/2448; E04B 2001/2451; E04B
 2001/2454; E04B 2001/2457; E04B
 2001/246; E04B 2001/2463; E04F 19/02;
 E04F 19/022; E04F 19/026; E04F 19/028;
 E04F 19/04; E04F 19/0436; E04F
 19/0481; E04F 19/0486; E04F 19/06;
 E04F 19/061; E04F 19/064; E04F
 2019/0404; E04F 2019/0413; E04F
 2019/0422; E04F 2019/0454

See application file for complete search history.

(56) **References Cited**

U.S. PATENT DOCUMENTS

D382,654 S * 8/1997 DiGiorgio D25/124
 D433,161 S * 10/2000 Lockbeam D25/124
 D452,743 S * 1/2002 Edger D25/124
 D464,443 S * 10/2002 Franson D25/124
 D473,325 S * 4/2003 Schrader D25/124
 D493,540 S * 7/2004 Wickland D25/124
 D495,432 S * 8/2004 Franson D25/124
 D500,560 S * 1/2005 Willman D25/124
 D502,999 S * 3/2005 Wickland D25/124
 D557,824 S * 12/2007 Willman D25/124
 D557,825 S 12/2007 Willman
 D557,826 S * 12/2007 Willman D25/124
 D566,858 S * 4/2008 Fannan D25/124
 D576,299 S * 9/2008 Morton D25/124
 D576,747 S 9/2008 Morton et al.
 D578,663 S * 10/2008 Franson D25/124
 D578,665 S * 10/2008 Franson D25/124

D578,666 S * 10/2008 Franson D25/124
 D583,072 S * 12/2008 Campbell D25/124
 D583,080 S * 12/2008 Campbell D25/124
 D590,959 S * 4/2009 Franson D25/124
 D590,962 S 4/2009 Campbell et al.
 D590,964 S * 4/2009 Campbell D25/124
 D590,965 S * 4/2009 Campbell D25/124
 D591,432 S * 4/2009 Campbell D25/124
 D592,764 S * 5/2009 Campbell D25/124
 D593,686 S * 6/2009 Campbell D25/124
 D593,687 S * 6/2009 Campbell D25/124
 D597,220 S * 7/2009 Campbell D25/124
 D598,140 S * 8/2009 Bergmann D25/124
 D602,607 S * 10/2009 Wickland D25/124
 D602,609 S * 10/2009 Lockbeam D25/124
 D616,566 S 5/2010 Desrosiers et al.
 D651,725 S * 1/2012 Wickland D25/124
 D672,888 S 12/2012 Veryser
 D679,384 S * 4/2013 Morton D25/124
 D692,165 S * 10/2013 Fannan D25/124
 D692,586 S 10/2013 Fannan
 D692,589 S 10/2013 Wickland
 D692,590 S * 10/2013 Wickland D25/124
 D692,591 S * 10/2013 Kosonen D25/124
 D692,592 S 10/2013 Kosonen
 D693,023 S 11/2013 Fannan
 D693,489 S * 11/2013 Wickland D25/124
 D718,881 S 12/2014 Fannan
 D718,882 S 12/2014 Fannan
 D724,767 S * 3/2015 Cloutier D25/125
 D736,956 S * 8/2015 Chaney D25/124
 D736,957 S * 8/2015 Chaney D25/124
 D739,044 S * 9/2015 Campbell D25/124
 D739,045 S * 9/2015 Campbell D25/124
 D739,046 S * 9/2015 Campbell D25/124
 D739,562 S * 9/2015 Campbell D25/124
 D740,445 S 10/2015 Chaney et al.
 D740,446 S * 10/2015 Chaney D25/124
 D759,845 S * 6/2016 Marshall D25/124
 D759,846 S * 6/2016 Marshall D25/124
 D759,847 S * 6/2016 Marshall D25/124
 D759,848 S * 6/2016 Marshall D25/124
 D759,849 S * 6/2016 Marshall D25/124
 D759,850 S * 6/2016 Marshall D25/124
 D767,790 S * 9/2016 Chaney D25/124
 D769,465 S * 10/2016 Fannan D25/124
 D769,466 S * 10/2016 Fannan D25/124
 D769,467 S * 10/2016 Roberts D25/124
 D795,458 S * 8/2017 Marshall D25/125
 D795,462 S * 8/2017 Marshall D25/125
 D795,463 S * 8/2017 Marshall D25/125
 D795,464 S * 8/2017 Marshall D25/125
 2005/0050815 A1 3/2005 Engebretson

* cited by examiner

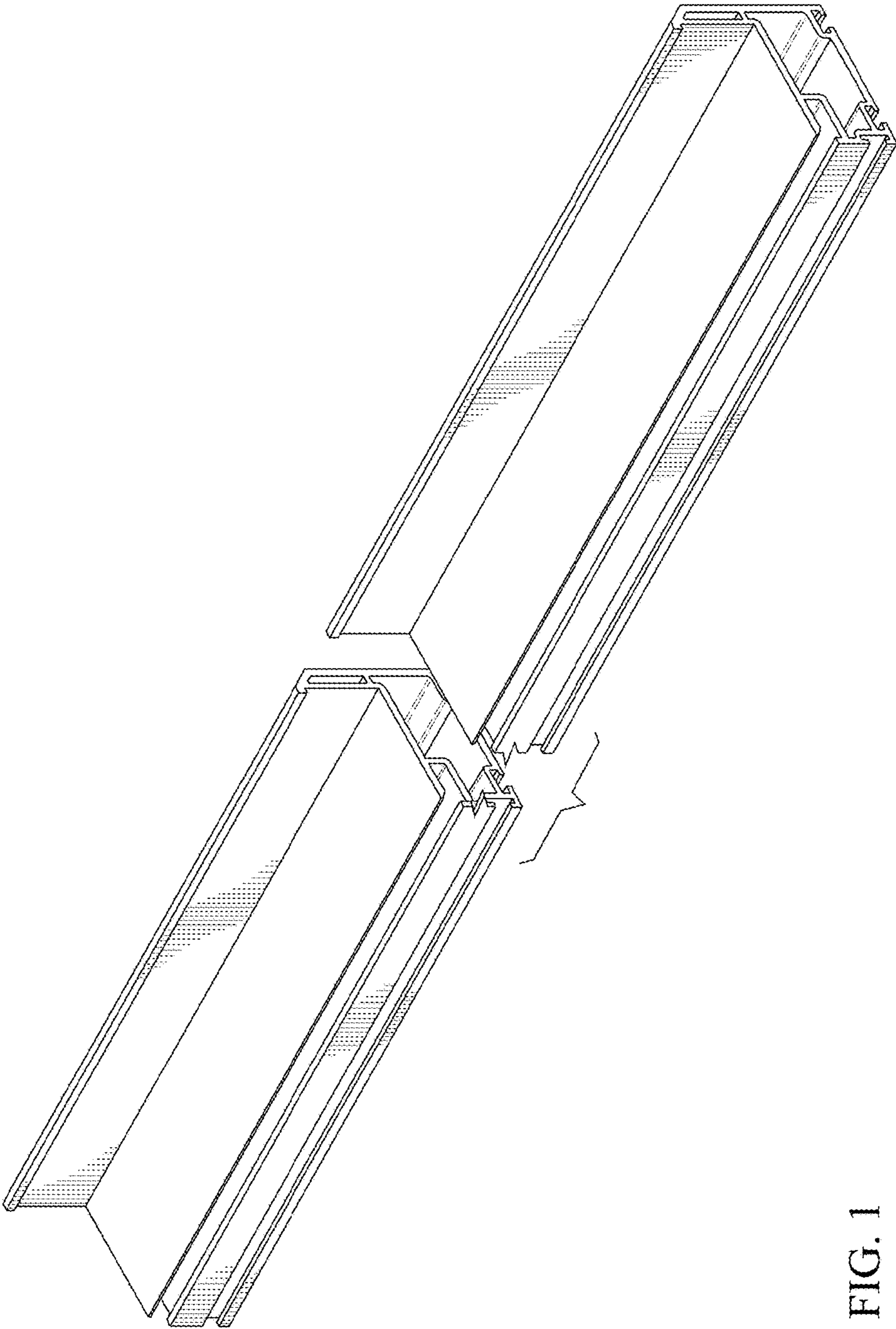

FIG. 1

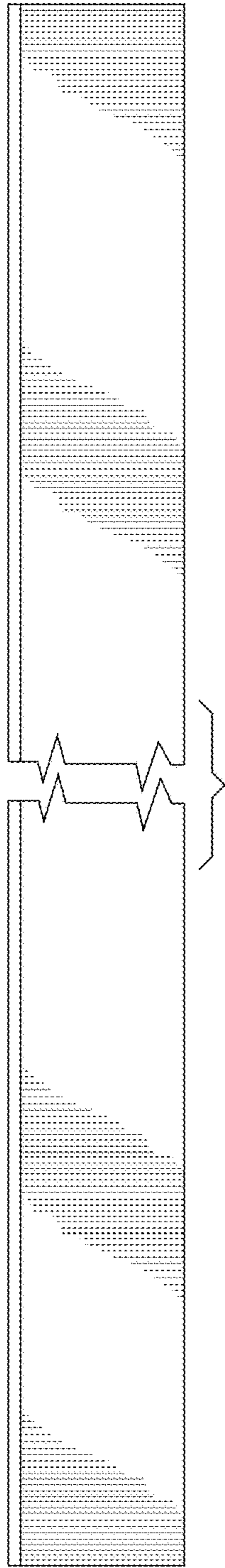

FIG. 2

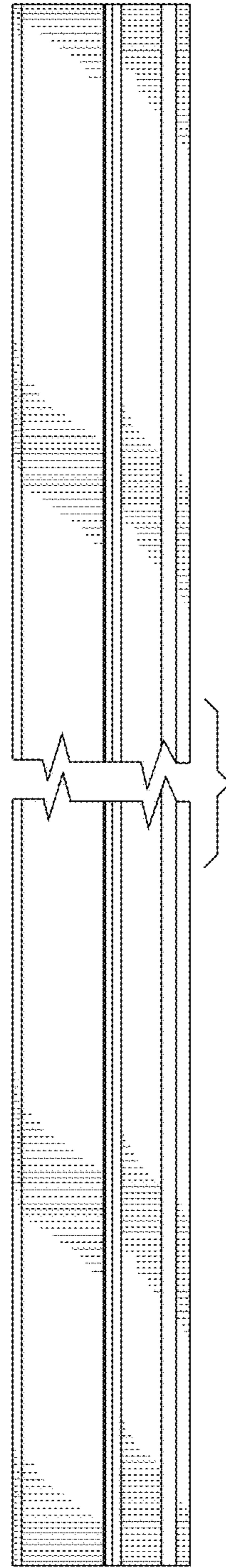

FIG. 3

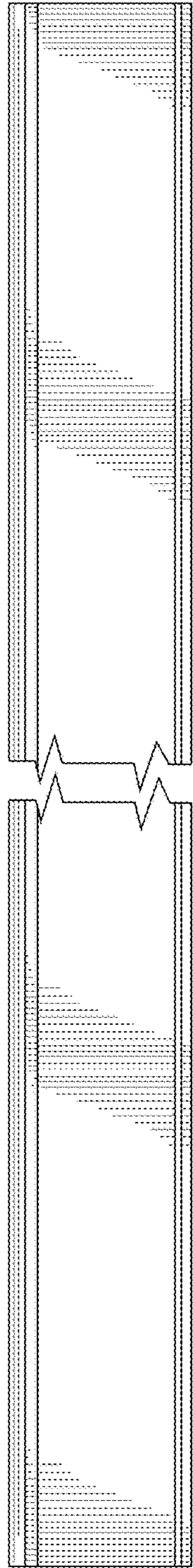

FIG. 4

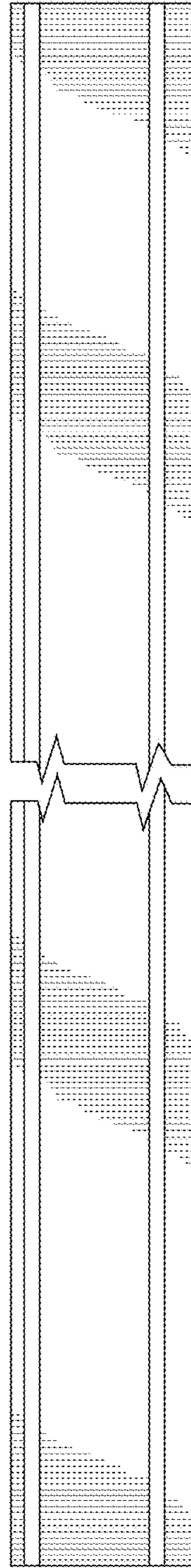

FIG. 5

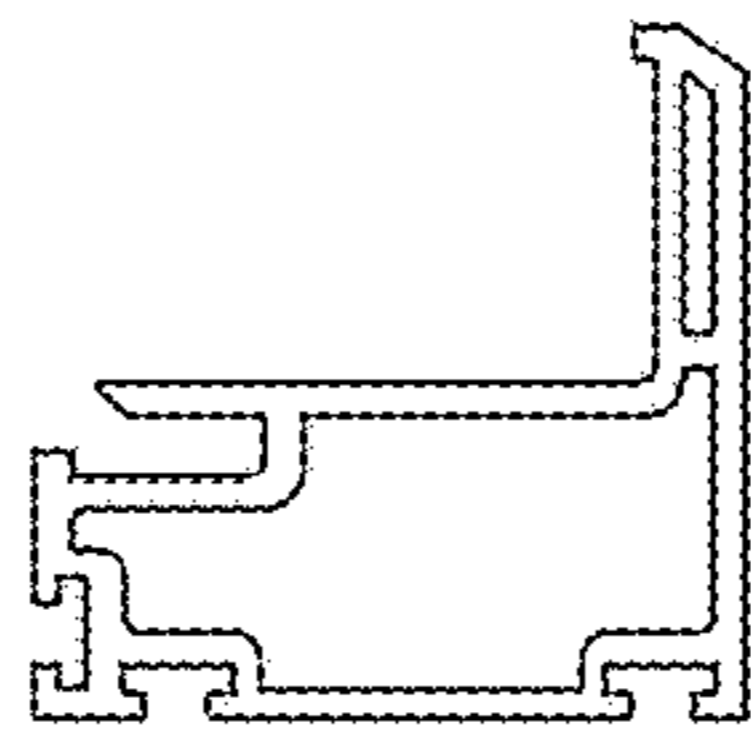

FIG. 6

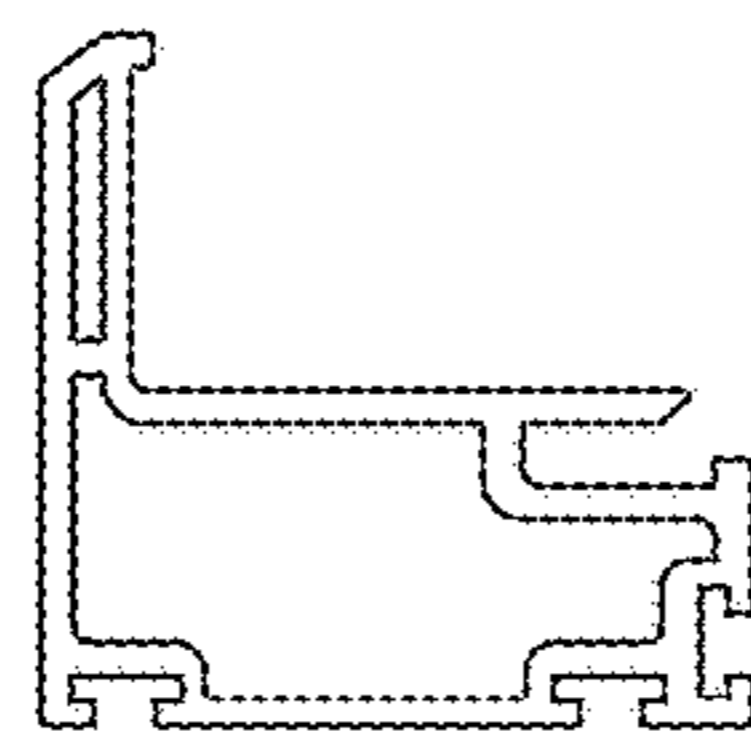

FIG. 7

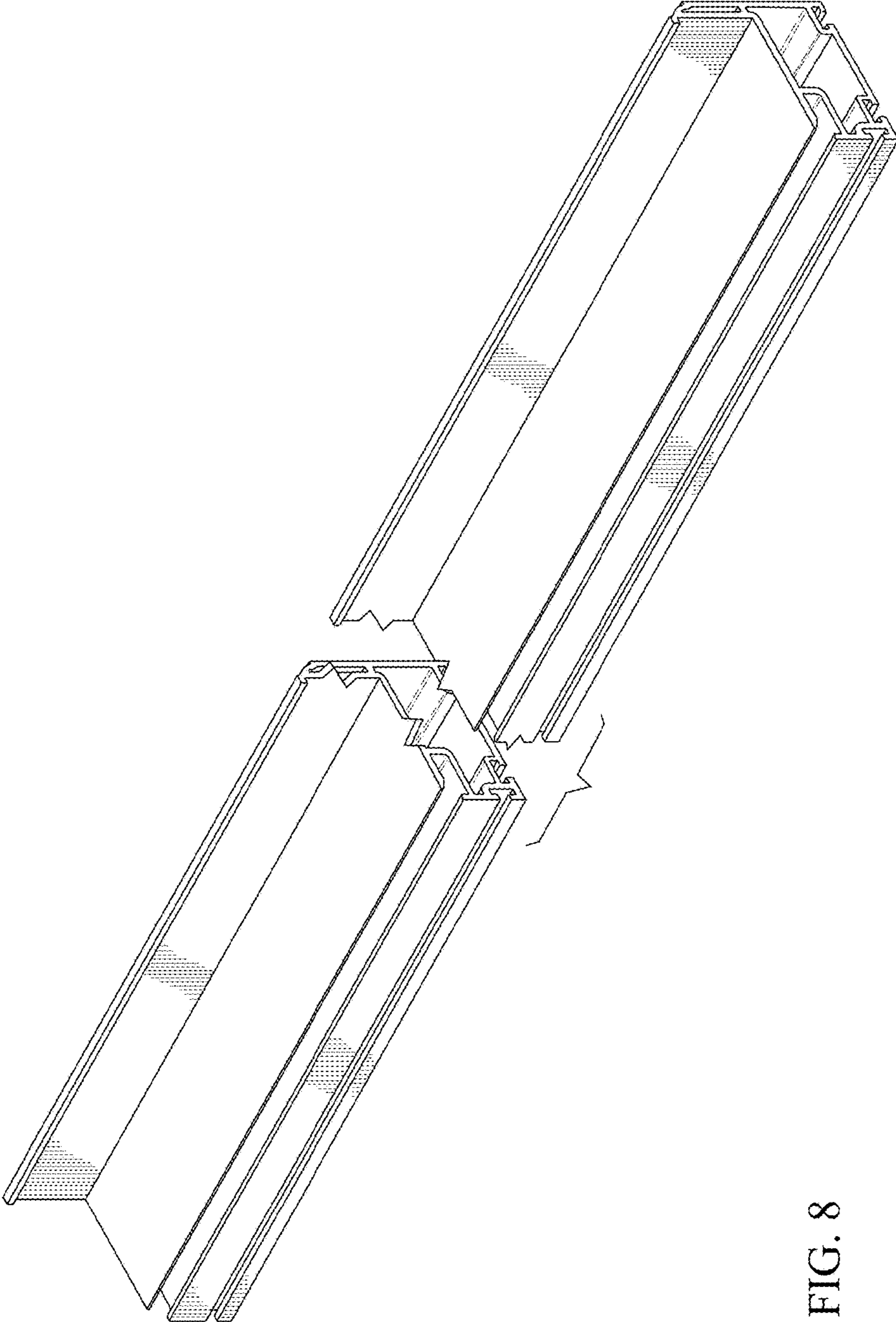

FIG. 8

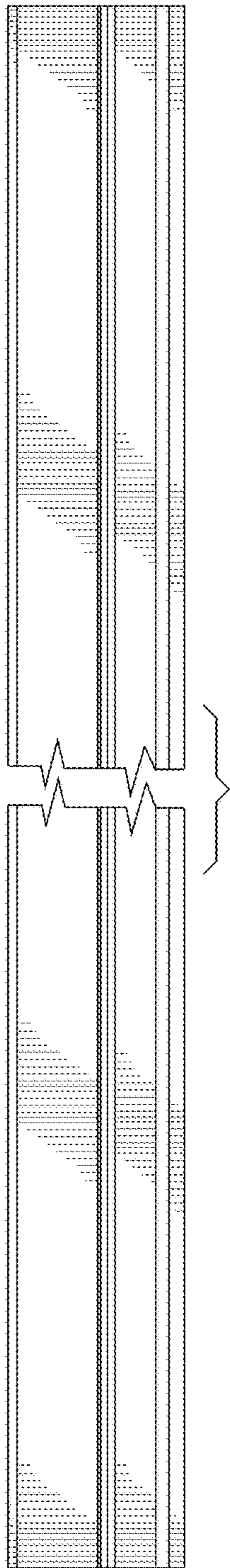

FIG. 9

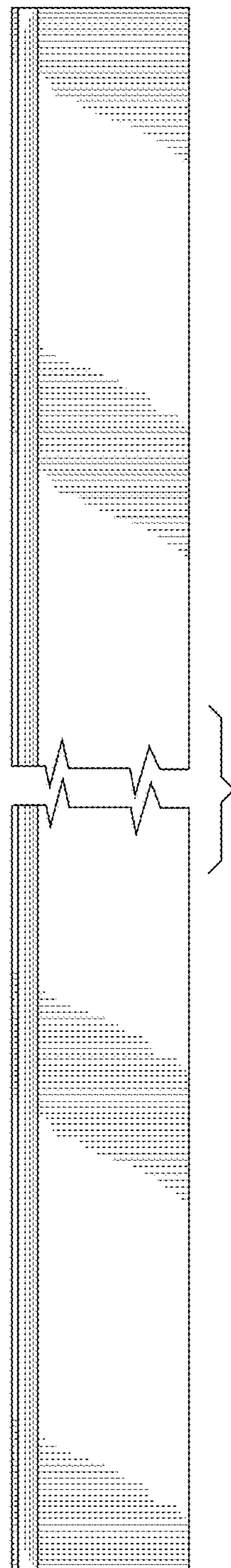

FIG. 10

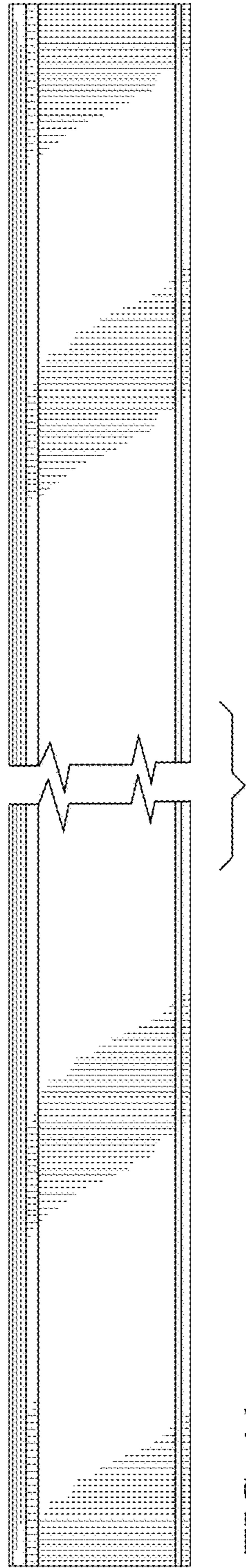

FIG. 11

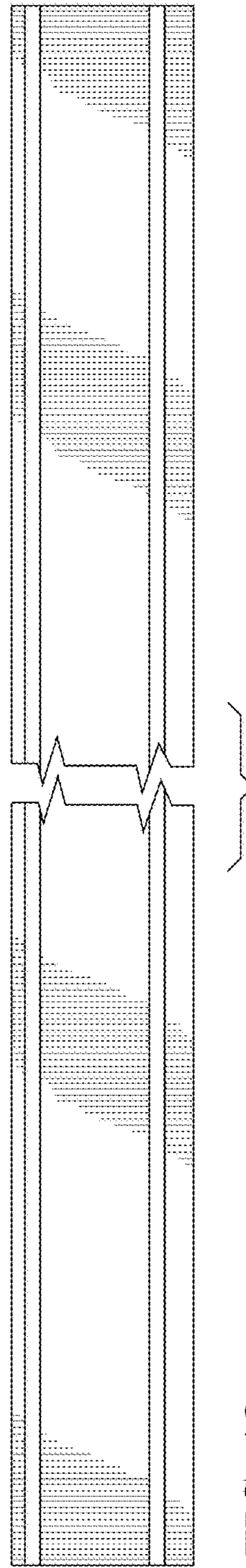

FIG. 12

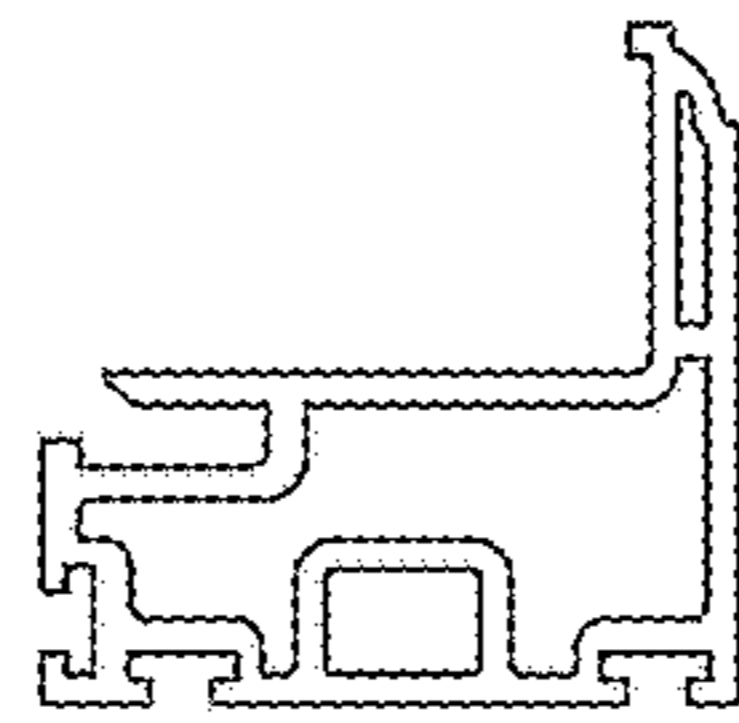

FIG. 13

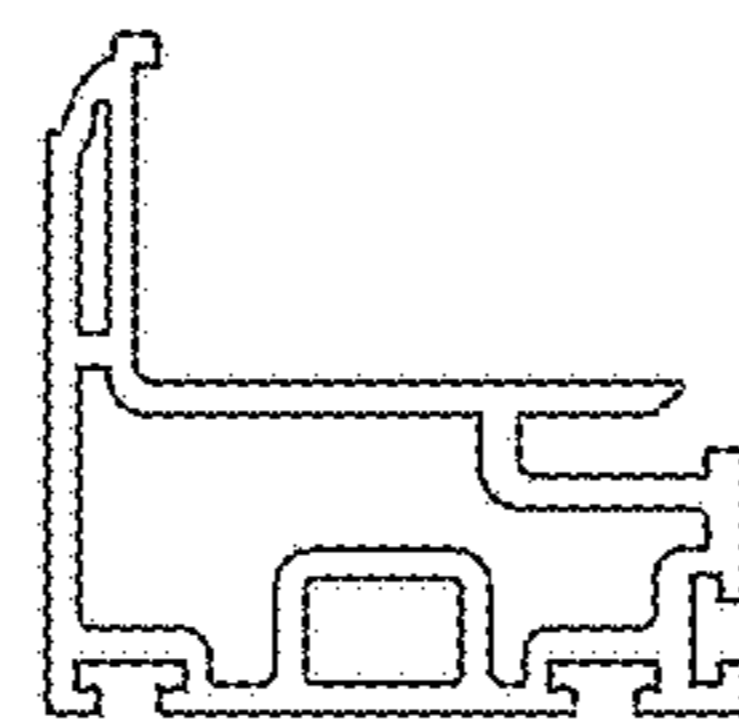

FIG. 14

UNITED STATES PATENT AND TRADEMARK OFFICE
CERTIFICATE OF CORRECTION

PATENT NO. : D836,216 S
APPLICATION NO. : 29/574483
DATED : December 18, 2018
INVENTOR(S) : William G. Roberts

Page 1 of 1

It is certified that error appears in the above-identified patent and that said Letters Patent is hereby corrected as shown below:

On the Title Page

Second column, DESCRIPTION, "FIG. 1 is a top front isometric view showing my new design." should read --FIG. 1 is a top front isometric view of a first embodiment of a window sash extrusion showing my new design.--.

Second column, DESCRIPTION, FIG. 2, "elevations" should read --elevational--.

Second column, DESCRIPTION, "FIG. 8 is a top front isometric view another embodiment of my window sash extrusion design," should read --FIG. 8 is a top front isometric view of a second embodiment of the window sash extrusion in FIG. 1.--.

Second column, DESCRIPTION, FIG. 9, "elevation" should read --elevational--.

Signed and Sealed this
Second Day of April, 2019

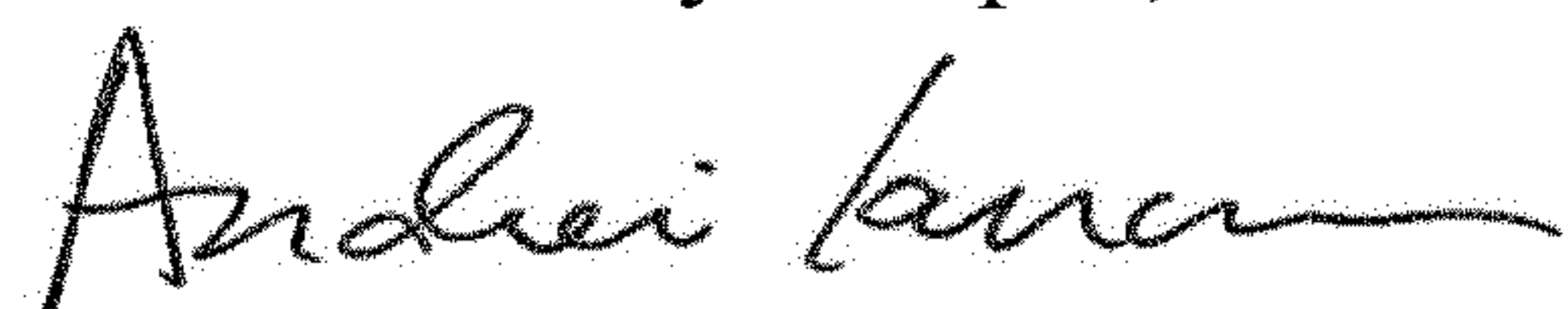

Andrei Iancu
Director of the United States Patent and Trademark Office