



US00D836055S

(12) **United States Design Patent**  
**Buck**

(10) **Patent No.:** **US D836,055 S**

(45) **Date of Patent:** **\*\* Dec. 18, 2018**

(54) **WHEEL**

(71) Applicant: **Jaguar Land Rover Limited**, Whitley,  
Coventry (GB)

(72) Inventor: **Joe Buck**, Coventry (GB)

(73) Assignee: **Jaguar Land Rover Limited**, Whitley  
Coventry (GB)

(\*\*) Term: **15 Years**

(21) Appl. No.: **29/629,072**

(22) Filed: **Dec. 11, 2017**

**Related U.S. Application Data**

(62) Division of application No. 29/567,921, filed on Jun.  
14, 2016, now Pat. No. Des. 808,323.

**Foreign Application Priority Data**

Jan. 14, 2016 (EM) ..... 002945345-0006

(51) **LOC (11) Cl.** ..... **12-16**

(52) **U.S. Cl.**  
USPC ..... **D12/209**

(58) **Field of Classification Search**

USPC ..... D12/204-213  
CPC .... B60B 7/00; B60B 7/02; B60B 7/04; B60B  
7/01; B60B 7/06; B60B 3/02; B60B 3/04;  
B60B 3/06; B60B 3/10; B60B 1/00;  
B60B 1/08; B60B 1/10; B60B 1/12

See application file for complete search history.

(56) **References Cited**

**U.S. PATENT DOCUMENTS**

D587,181 S *	2/2009	Musser .....	D12/209
D597,919 S *	8/2009	Atwell .....	D12/211
D626,052 S *	10/2010	Majdandzic .....	D12/209
D649,102 S *	11/2011	Gallert .....	D12/211
D675,143 S *	1/2013	Gebert .....	D12/209
D739,326 S *	9/2015	Juergens .....	D12/209
D741,240 S *	10/2015	Melabiotis .....	D12/209
D743,315 S *	11/2015	Perini .....	D12/209
D748,030 S *	1/2016	Heizmann .....	D12/209
D754,052 S *	4/2016	Juergens .....	D12/211
D764,367 S *	8/2016	Gallert .....	D12/209
D789,421 S *	6/2017	Wrobel .....	D14/496
D808,323 S *	1/2018	Buck .....	D12/209
D822,572 S *	7/2018	Smith .....	D12/209

\* cited by examiner

*Primary Examiner* — Stacia A Cadmus

(74) *Attorney, Agent, or Firm* — Wood Herron & Evans  
LLP

(57) **CLAIM**

The ornamental design for a wheel, as shown and described.

**DESCRIPTION**

FIG. 1 is a front left perspective view of a wheel according  
to the present invention.

FIG. 2 is a front view thereof.

FIG. 3 is a left side view thereof, the right side being  
identical thereto.

FIG. 4 is a rear view thereof; and,

FIG. 5 is a rear right perspective view thereof.

The broken line showing of the valve stem hole is included  
for the purpose of illustrating environment and forms no part  
of the claimed design.

**1 Claim, 3 Drawing Sheets**

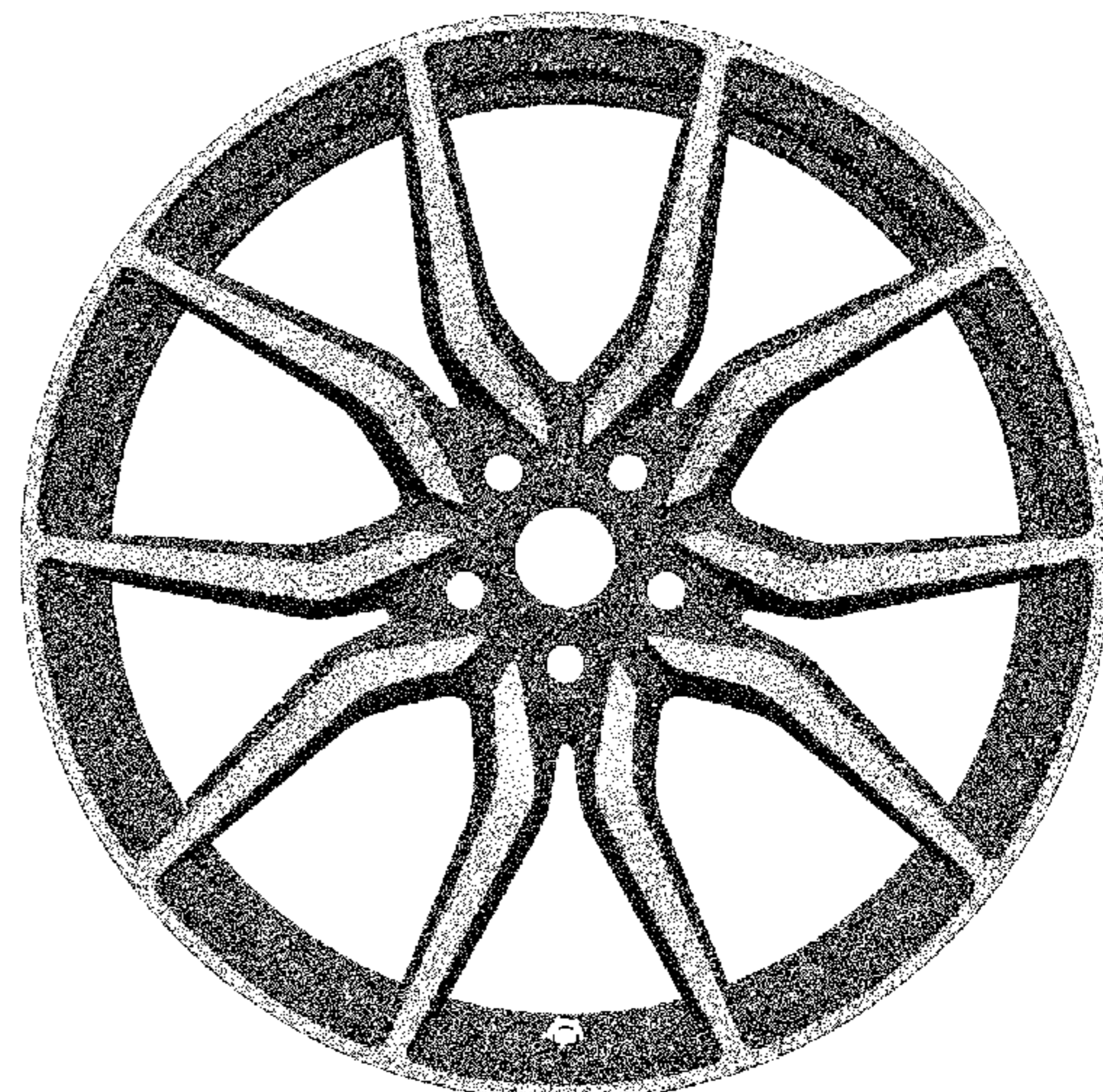
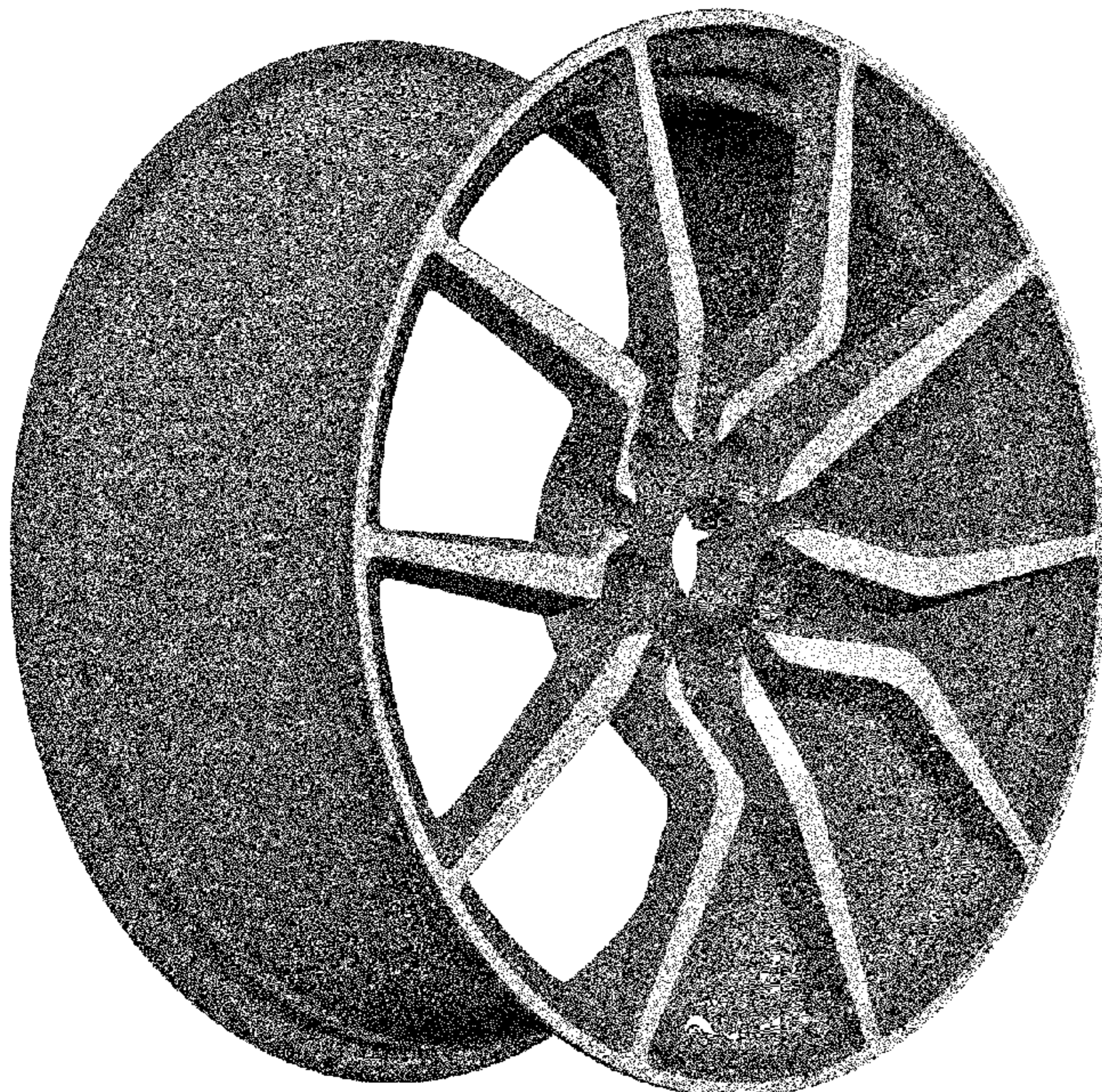





FIG. 1



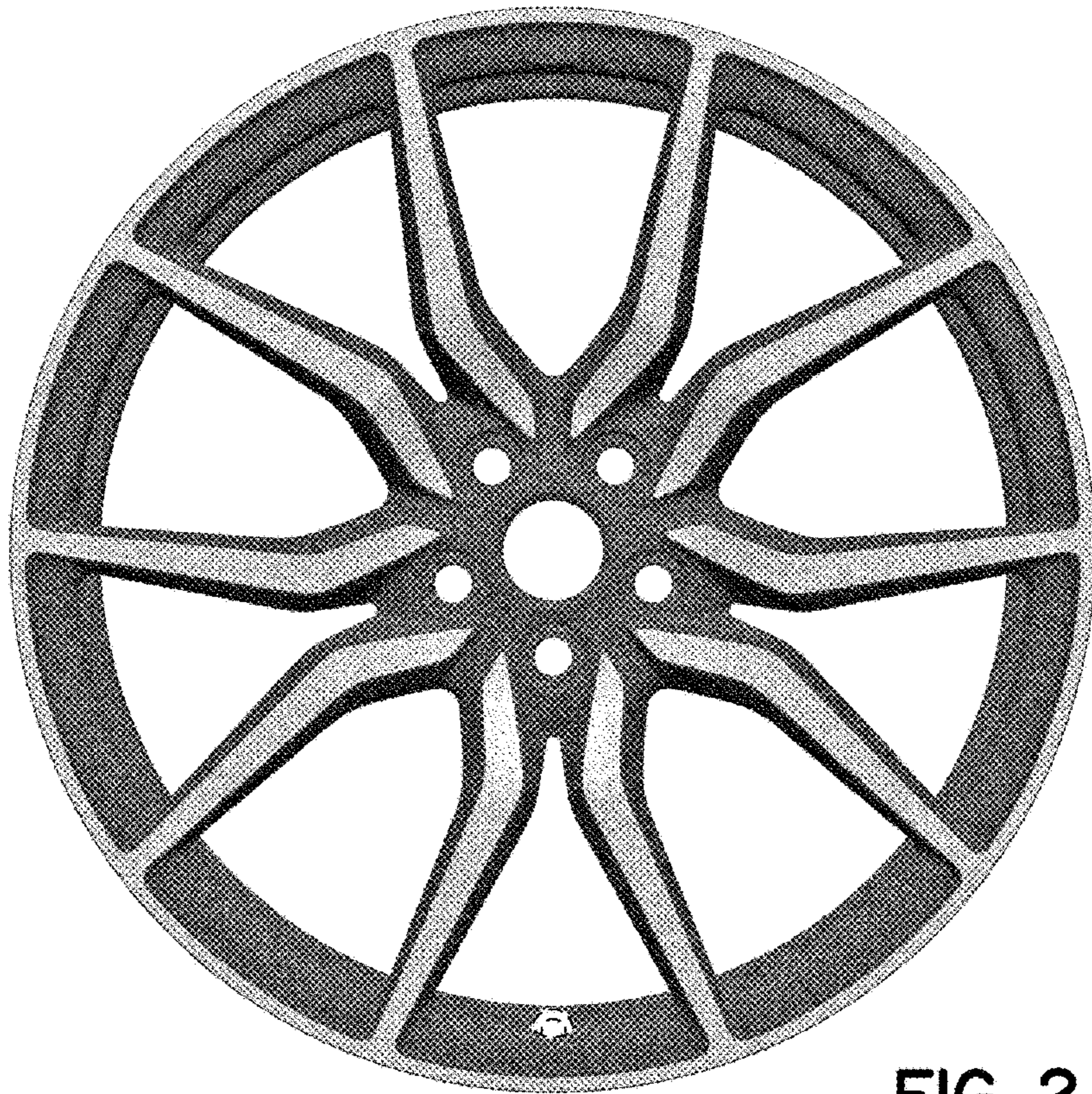

FIG. 2

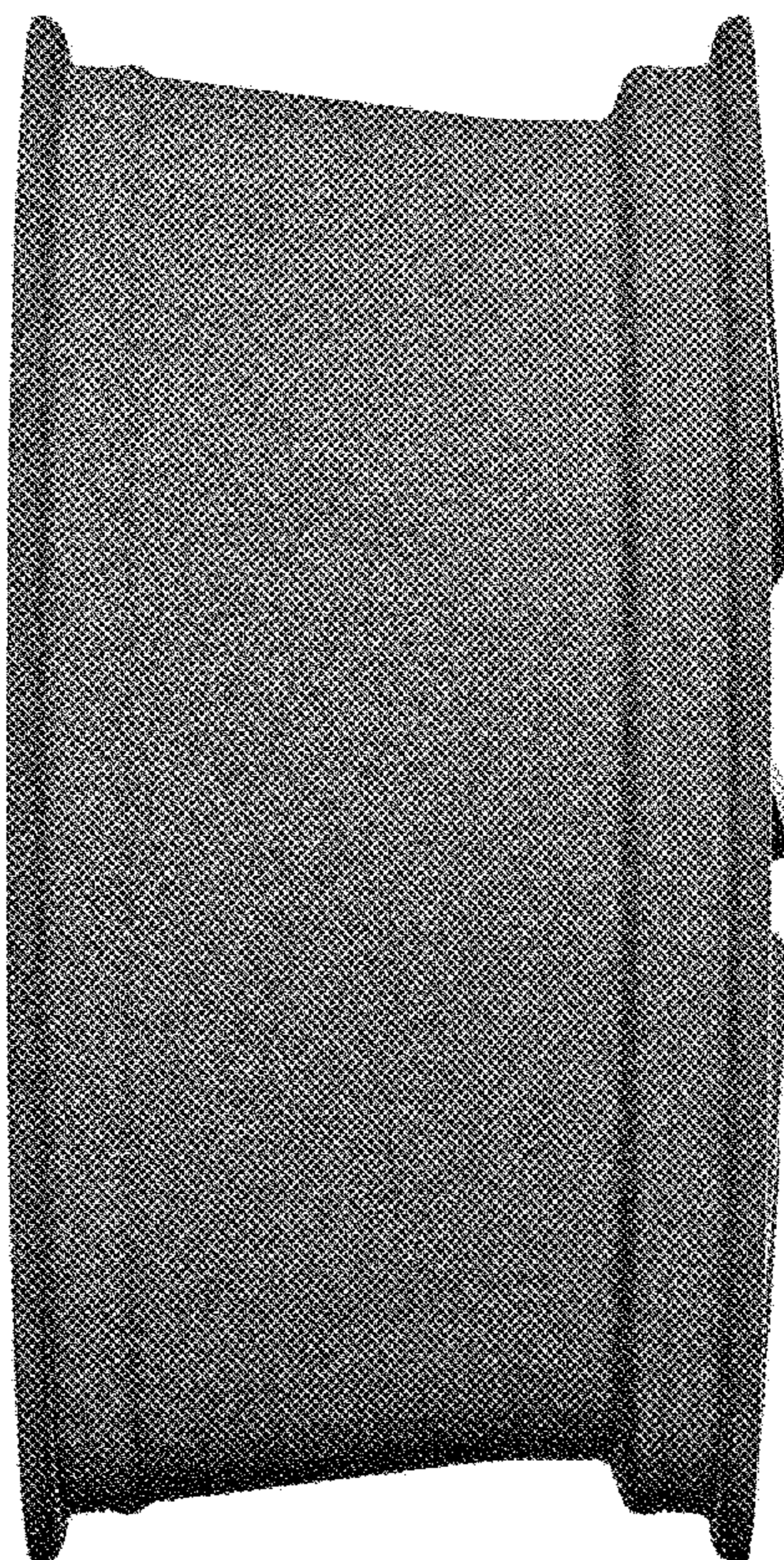

FIG. 3



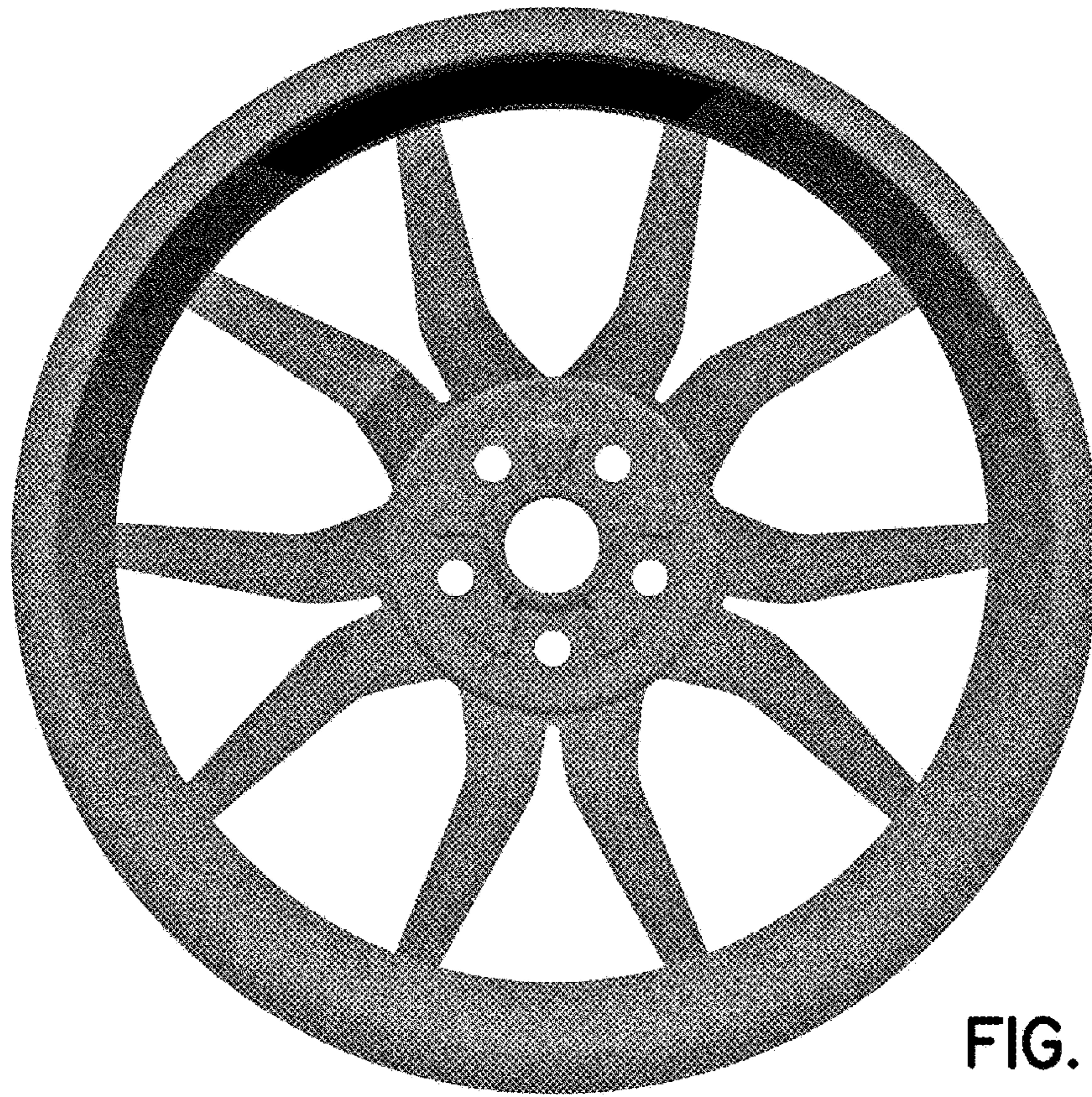

FIG. 4

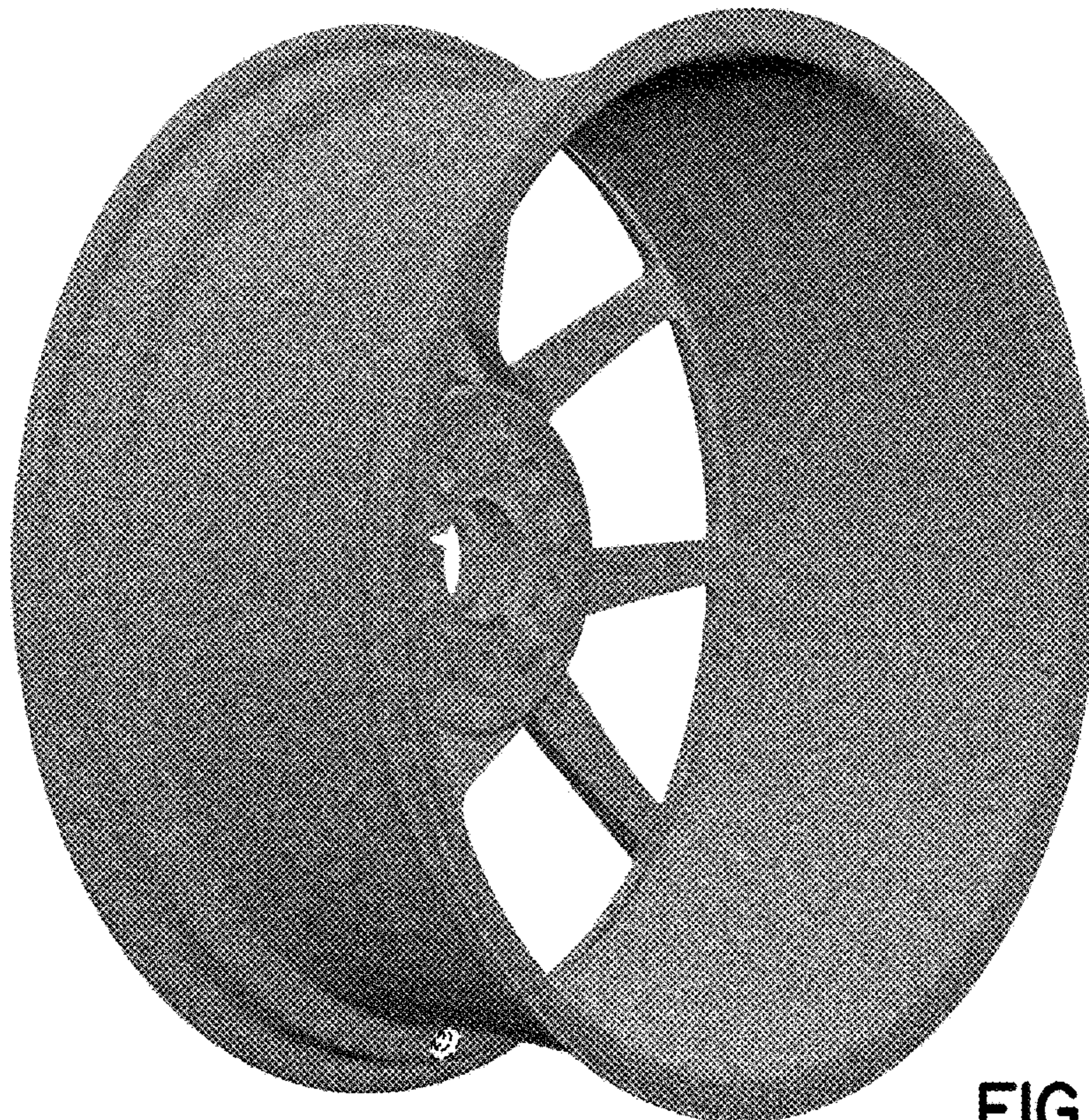

FIG. 5