



US00D835721S

(12) **United States Design Patent** (10) **Patent No.:** **US D835,721 S**
Ohyama (45) **Date of Patent:** **** Dec. 11, 2018**

- (54) **ADVERTISING DEVICE**
- (71) Applicant: **National Institute of Advanced Industrial Science and Technology, Tokyo (JP)**
- (72) Inventor: **Junji Ohyama, Tsukuba (JP)**
- (73) Assignee: **National Institute of Advanced Industrial Science and Technology, Tokyo (JP)**
- (**) Term: **15 Years**
- (21) Appl. No.: **29/589,944**
- (22) Filed: **Jan. 5, 2017**
- (30) **Foreign Application Priority Data**
Jul. 6, 2016 (JP) 2016-014354
- (51) **LOC (11) Cl.** **20-03**
- (52) **U.S. Cl.**
USPC **D20/10**
- (58) **Field of Classification Search**
USPC D1/116, 127, 128, 130; D7/354, 610;
D10/111, 113.1, 113.4; D20/10, 17-21,
D20/39, 41, 42, 99; D25/10; D26/23,
D26/31, 36, 40, 46, 85, 118-124, 128,
D26/130, 136
CPC G09F 7/00; G09F 7/10; G09F 9/00; G09F
9/3023; G09F 9/33; G09F 11/00; G09F
13/00; G09F 15/00; G09F 27/00; G09F
2013/0454; G09F 13/04; G09F 13/20
See application file for complete search history.

- D40,181 S * 7/1909 Mygatt D26/130
- 2,194,364 A * 3/1940 Minor A47G 27/0412
15/244.4
- 2,218,291 A * 10/1940 Muller F21V 7/10
362/350
- 2,579,467 A * 12/1951 Brickman E01F 9/578
404/12

(Continued)

OTHER PUBLICATIONS

Let there be (dollar store) light!, posted at Atcharlotteshouse.com, posted on Mar. 6, 2014, site visited Dec. 18, 2017. online, Available from Internet: <https://atcharlotteshouse.com/let-there-be-dollar-store-light/>.*

(Continued)

Primary Examiner — Mary Ann Calabrese
Assistant Examiner — Catherine Ho
(74) *Attorney, Agent, or Firm* — Lucas & Mercanti, LLP

(57) **CLAIM**

The ornamental design for advertising device, as shown and described.

DESCRIPTION

FIG. 1 is a front view of an advertising device;
FIG. 2 is a back view thereof;
FIG. 3 is a left side view thereof;
FIG. 4 is a right side view thereof;
FIG. 5 is a top plan view thereof;
FIG. 6 is a bottom view thereof;
FIG. 7 is a perspective view thereof;
FIG. 8 is another perspective view thereof;
FIG. 9 is a top perspective view thereof; and,
FIG. 10 is a bottom perspective view thereof.
The oblique shade lines represent a transparent surface.
The broken lines showing of the advertising device is for the purpose of illustrating portions of the article and form no part of the claimed design.

1 Claim, 8 Drawing Sheets

- (56) **References Cited**
U.S. PATENT DOCUMENTS
666,683 A * 1/1901 Mygatt F21V 5/00
362/331
D37,982 S * 5/1906 Mygatt D26/136
D39,373 S * 6/1908 Rice D26/136

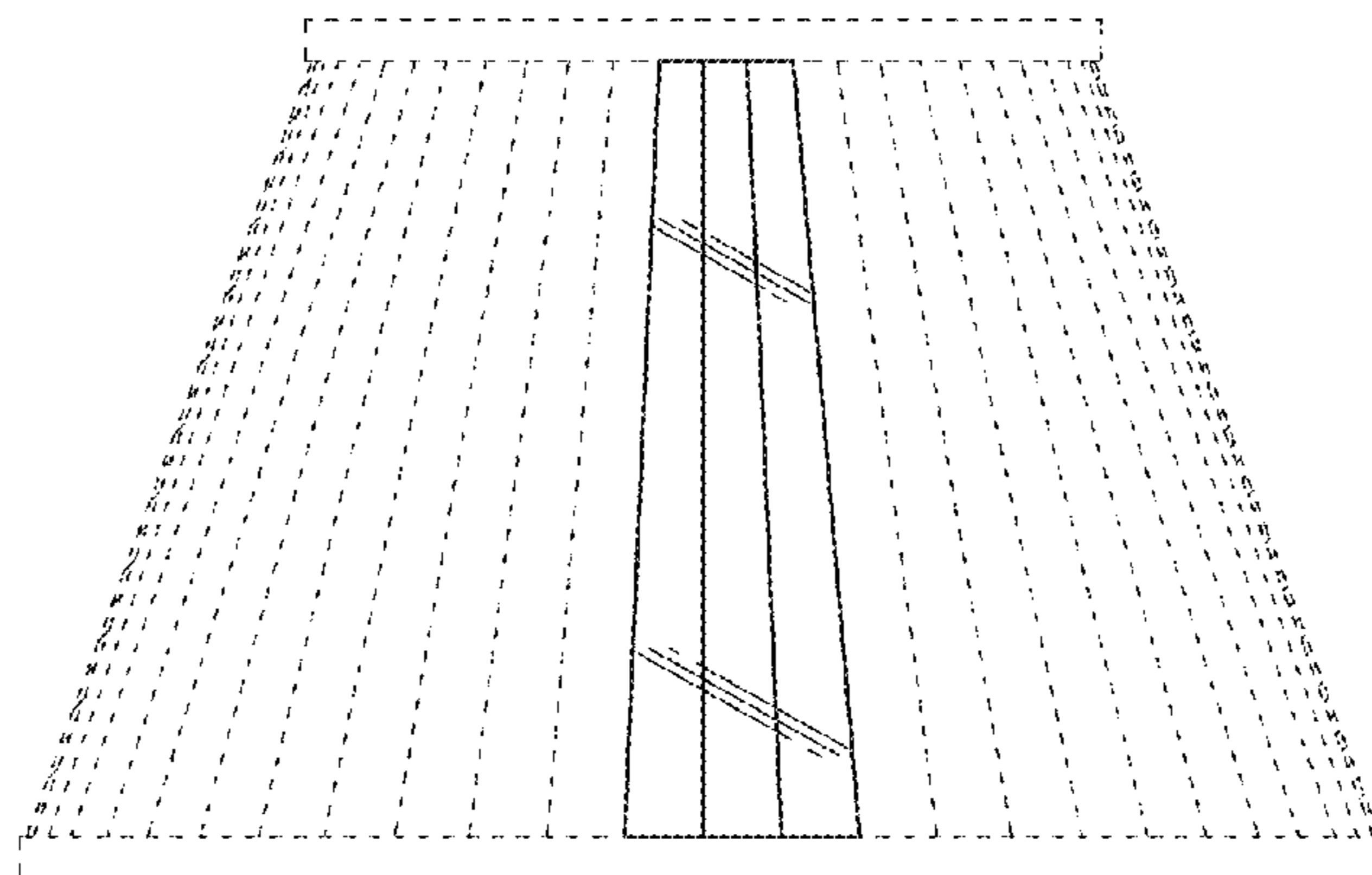

(56)

References Cited

U.S. PATENT DOCUMENTS

D366,724 S	*	1/1996	Keng	D26/134
D388,526 S	*	12/1997	Bray	D26/122
D498,016 S	*	11/2004	Herst	D26/118
D581,719 S	*	12/2008	Frank	D7/354
D636,527 S	*	4/2011	Yao	D26/134
D684,300 S	*	6/2013	Lin	D26/118

OTHER PUBLICATIONS

Wilton Red Petal Baking Cups, posted at Amazon.com, posted on Jan. 27, 2010, site visited Dec. 18, 2017. online, Available from Internet: <https://www.amazon.com/Wilton-Petal-Baking-Cups-Count/dp/B0054TVFKQ>.*

Pantry Elements Jumbo Silicone Muffin Cups, posted at Amazon.com, posted on Apr. 3, 2014, site visited Dec. 18, 2017. online, Available from Internet: <https://www.amazon.com/dp/B00E9KCKAU>.*

Wilton Baking Cups, posted at Amazon.com, posted on Feb. 7, 2015, site visited Dec. 18, 2017. online, Available from Internet: <https://www.amazon.com/Wilton-Baking-Cups-White-350-Count/product-reviews/B0026HT0BA>.*

* cited by examiner

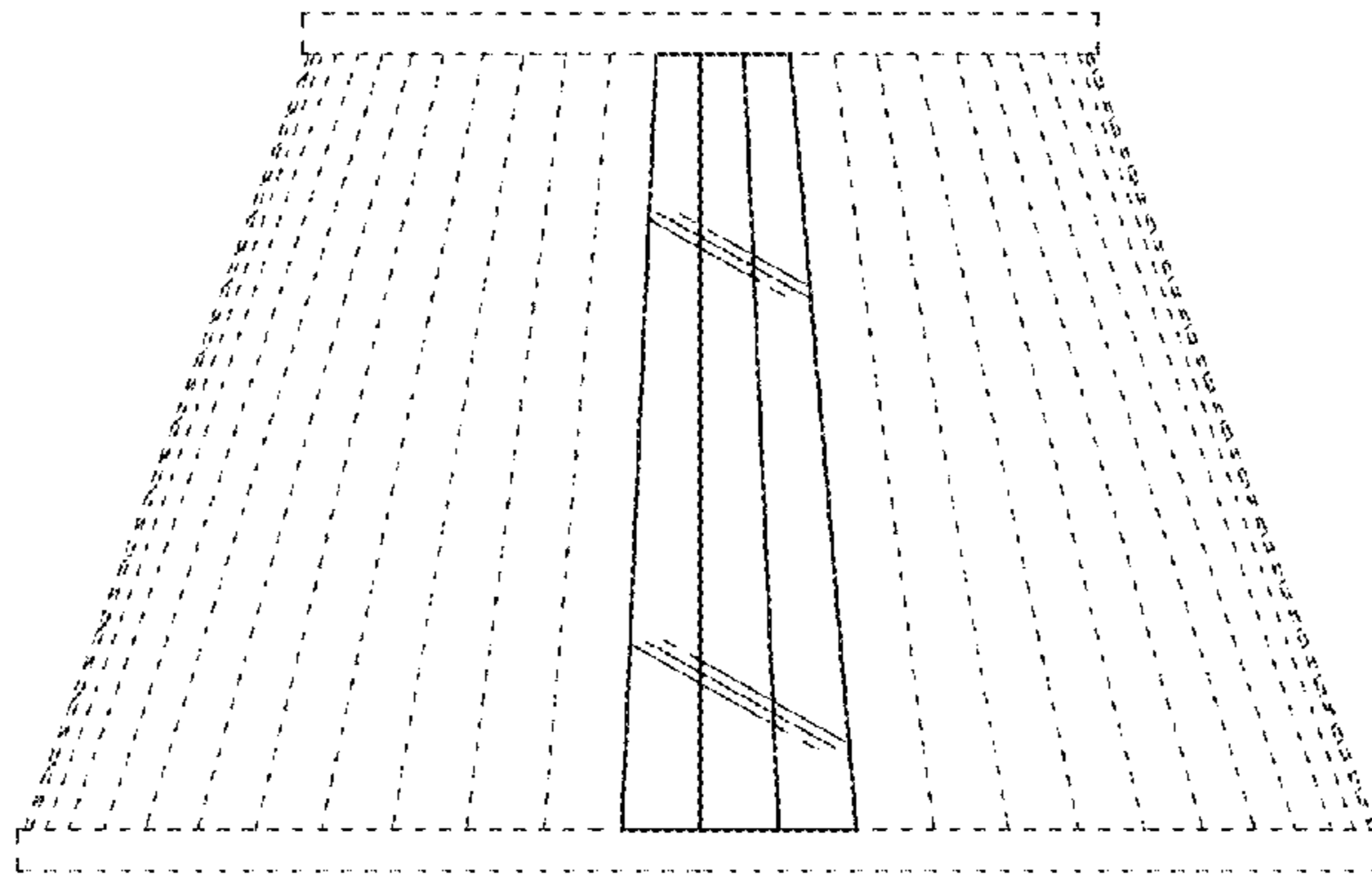

FIG. 1

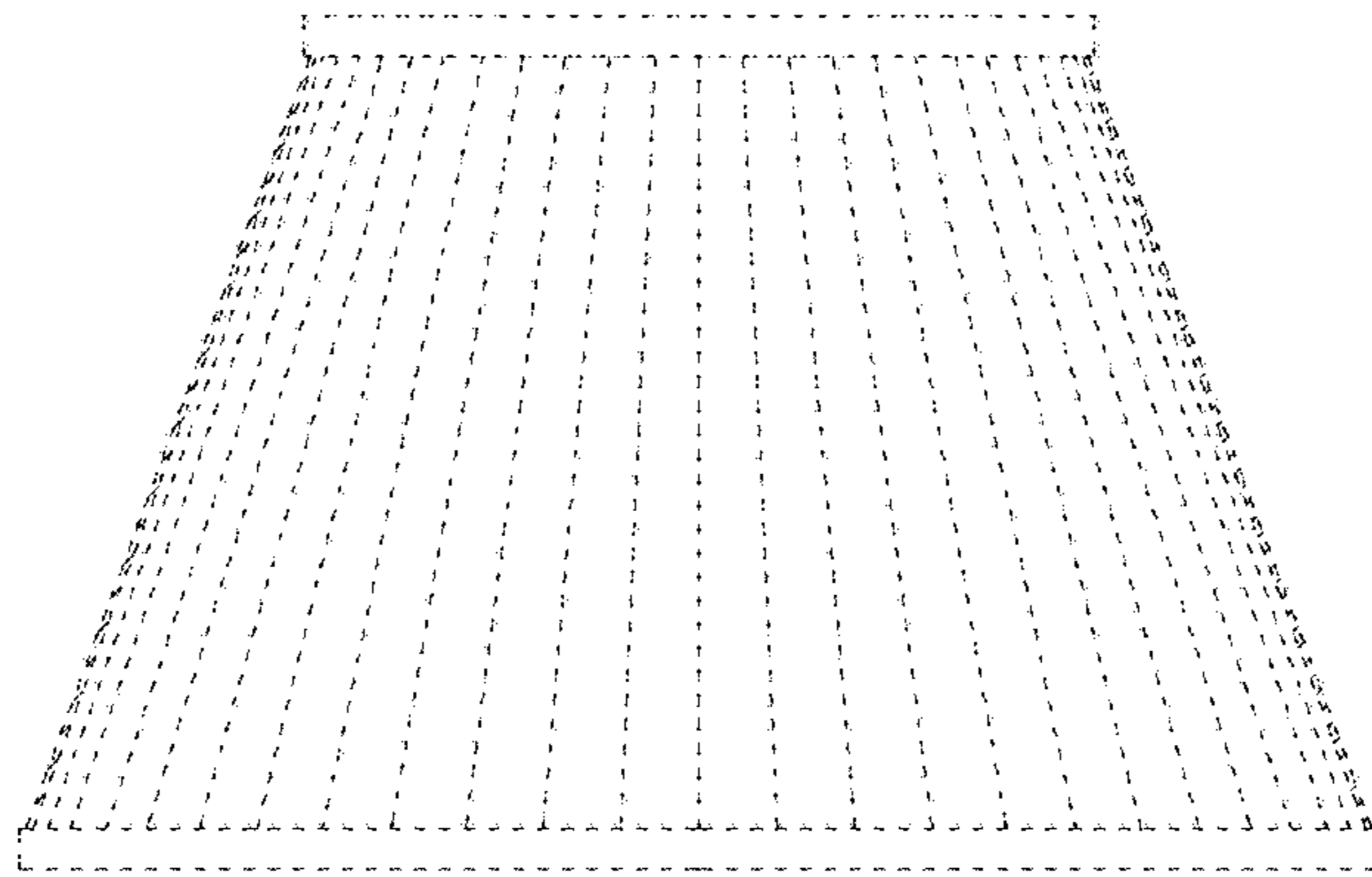

FIG. 2

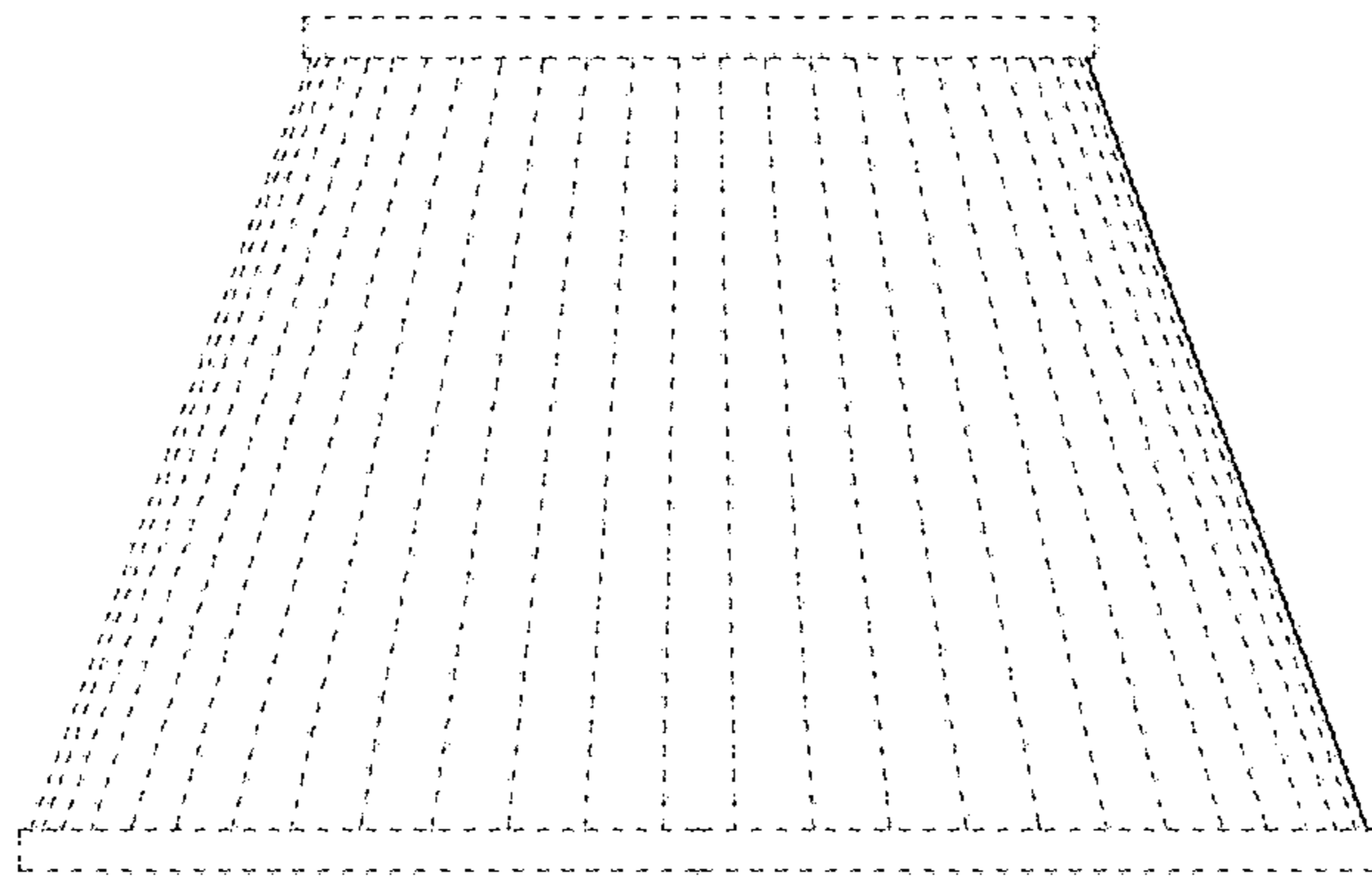

FIG. 3

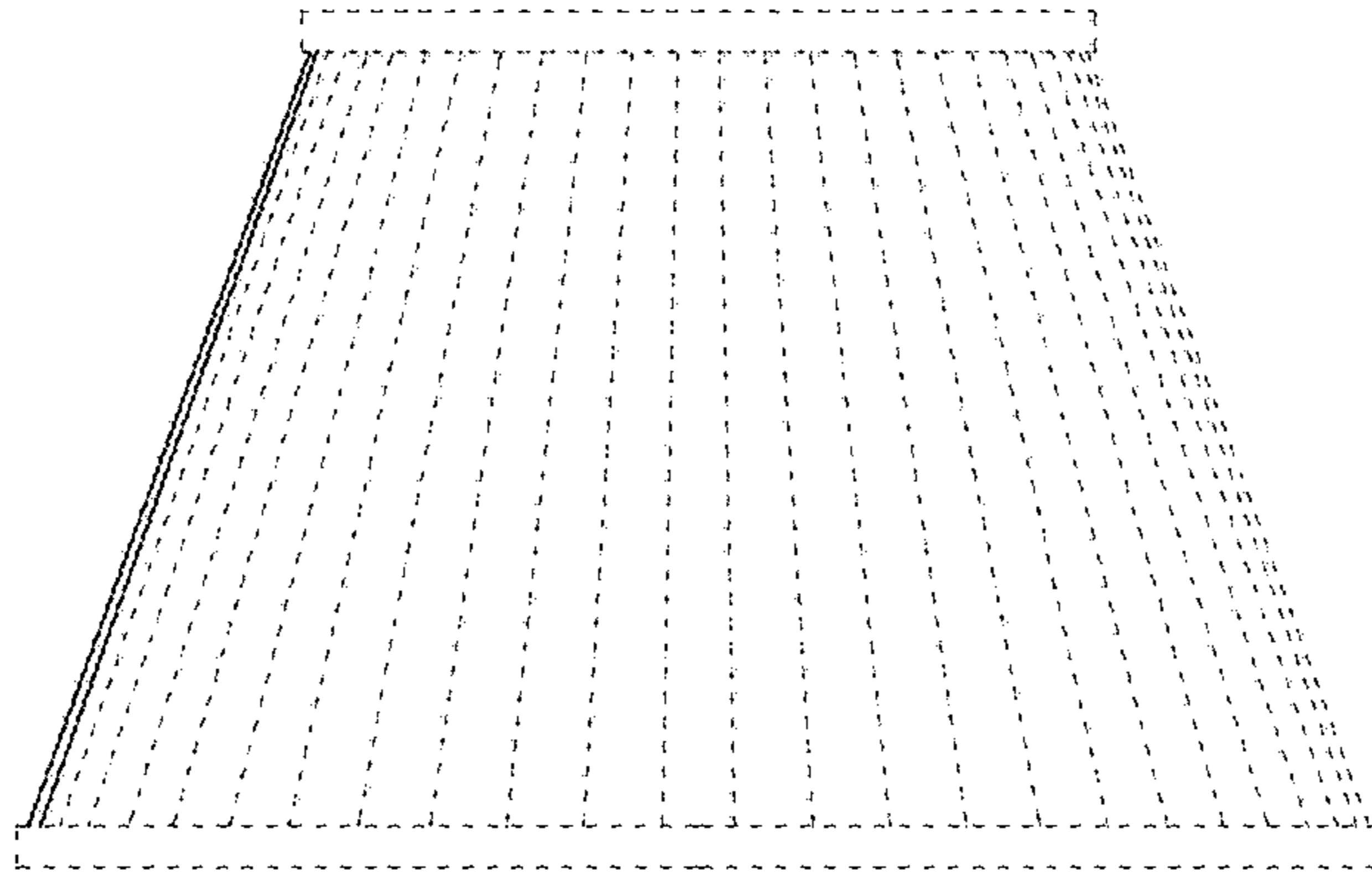

FIG. 4

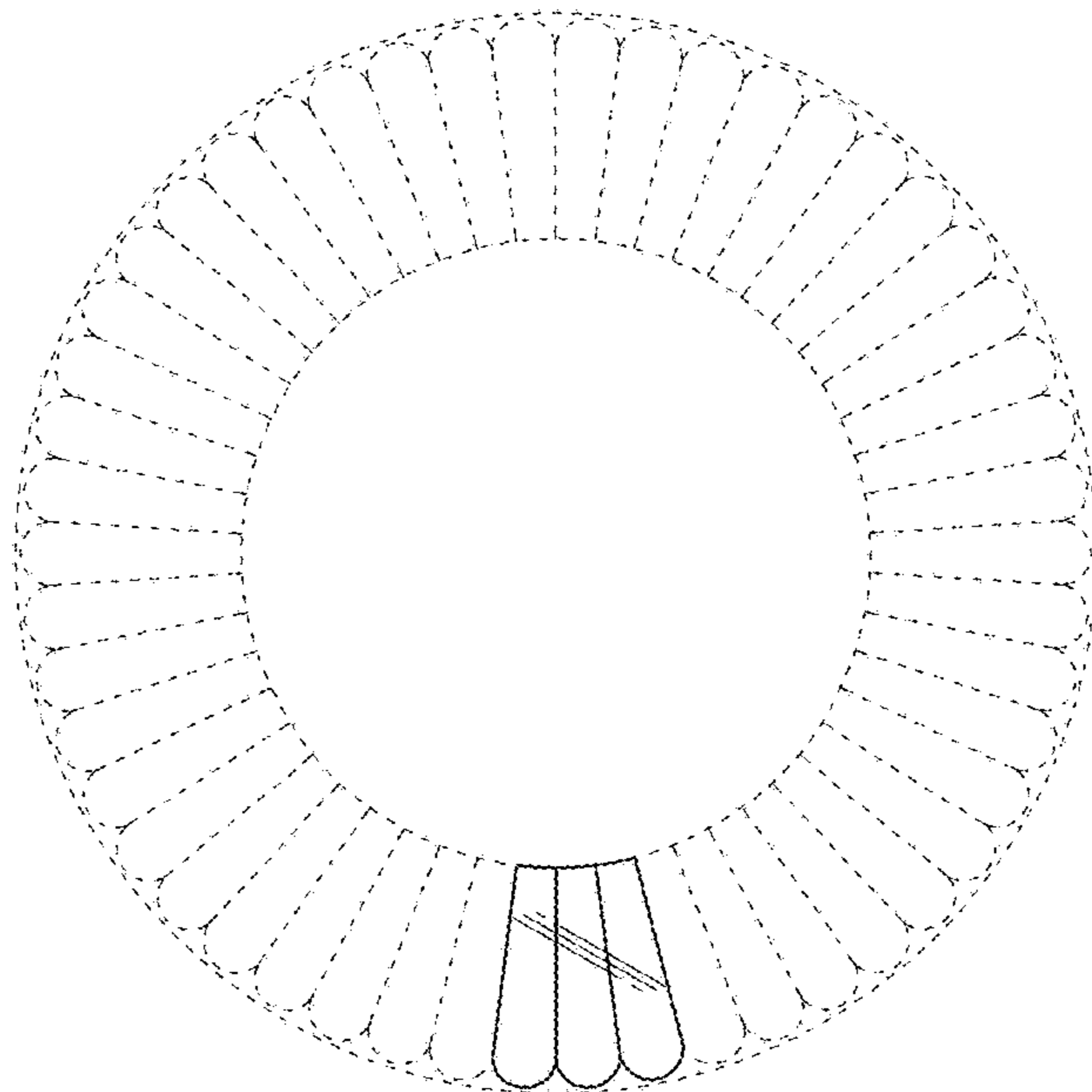

FIG. 5

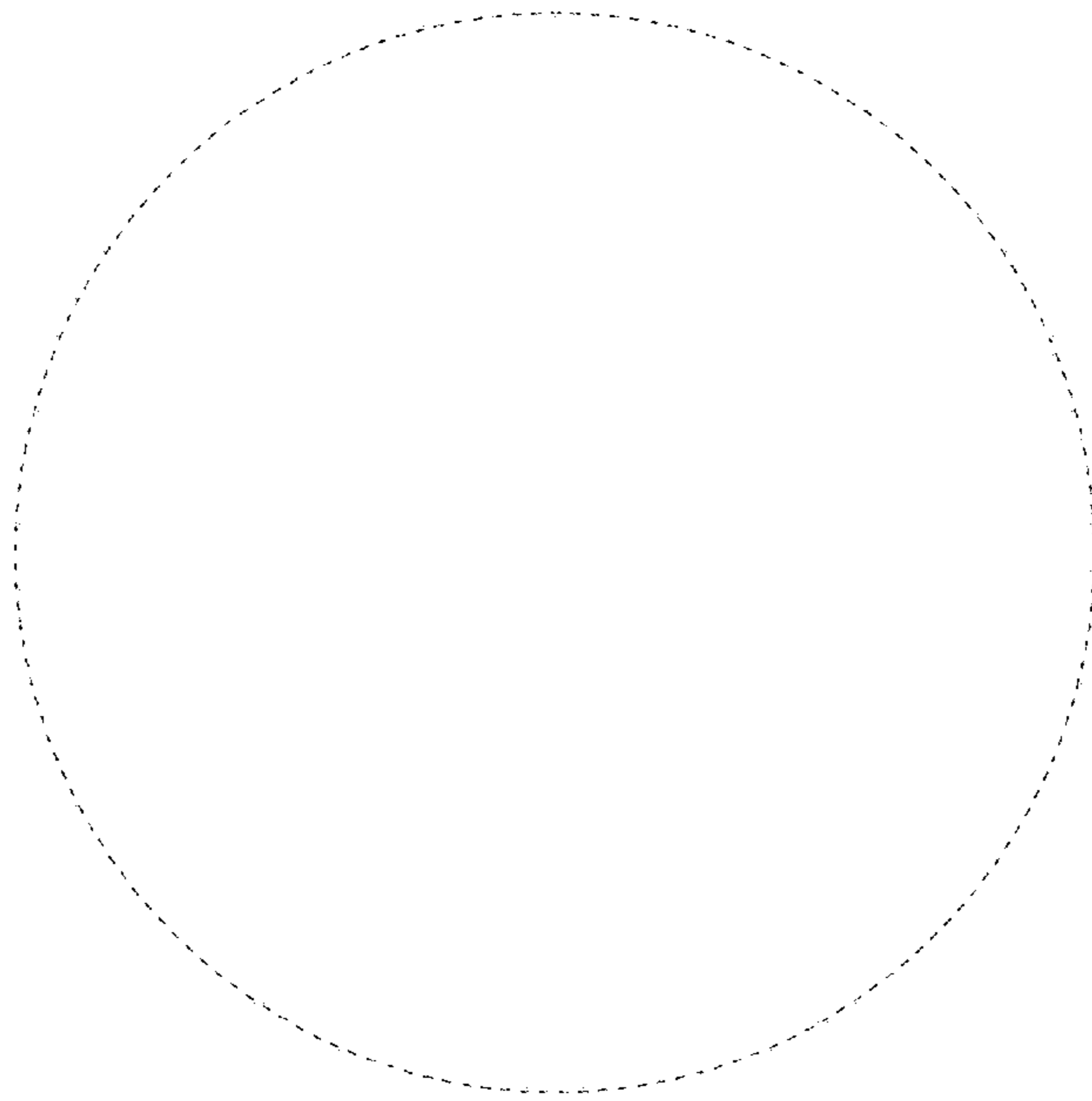

FIG. 6

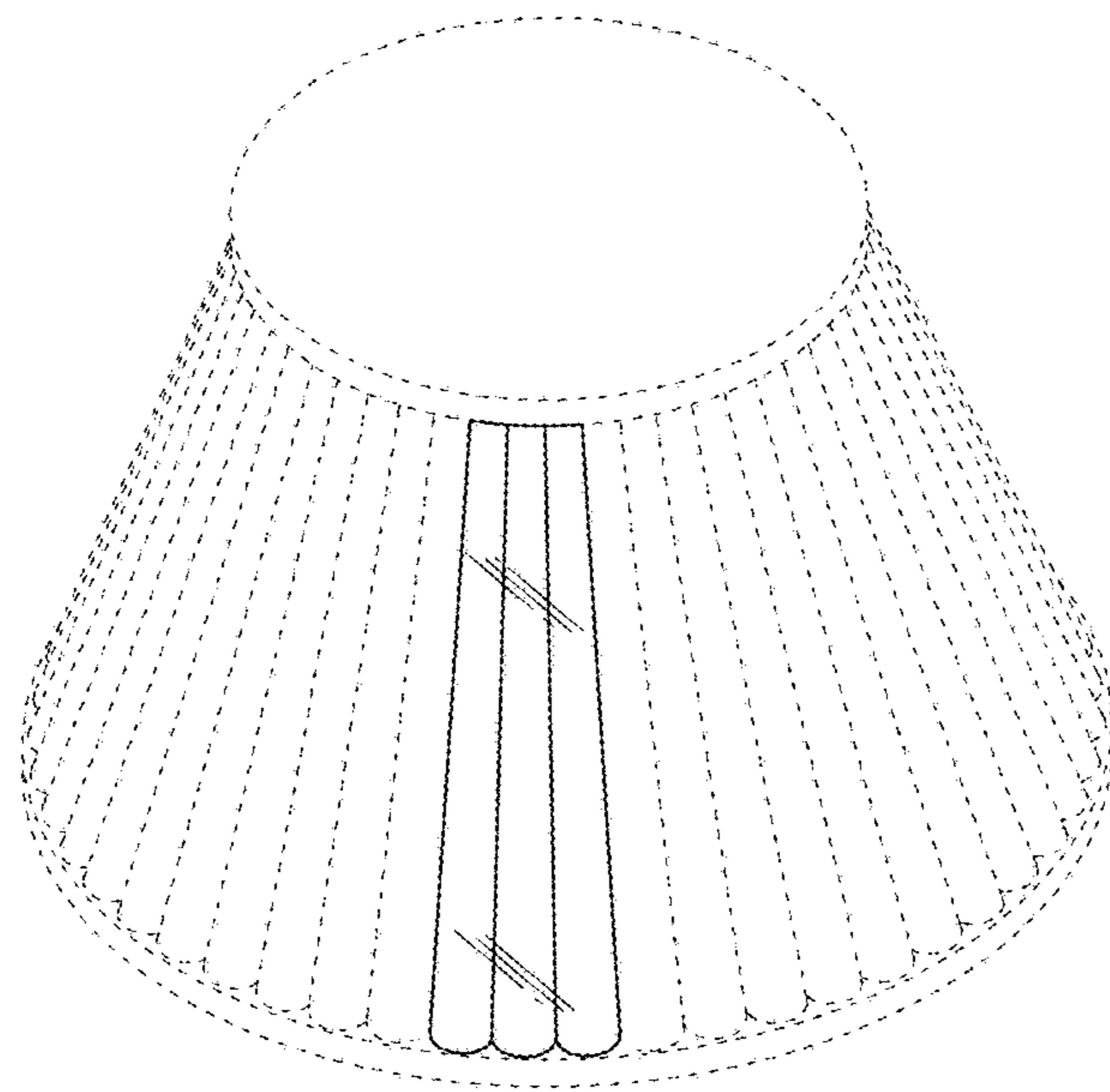

FIG. 7

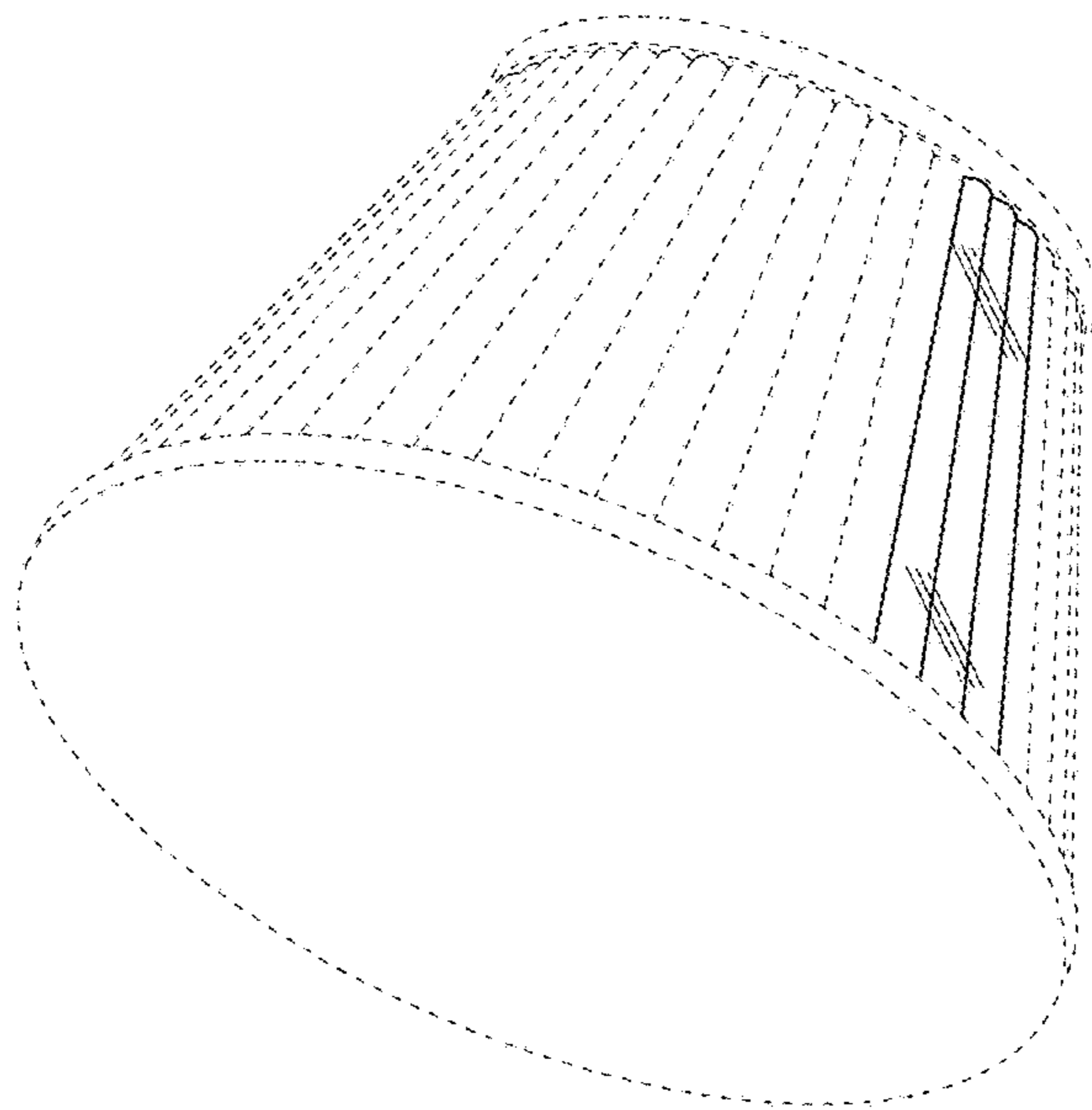

FIG. 8

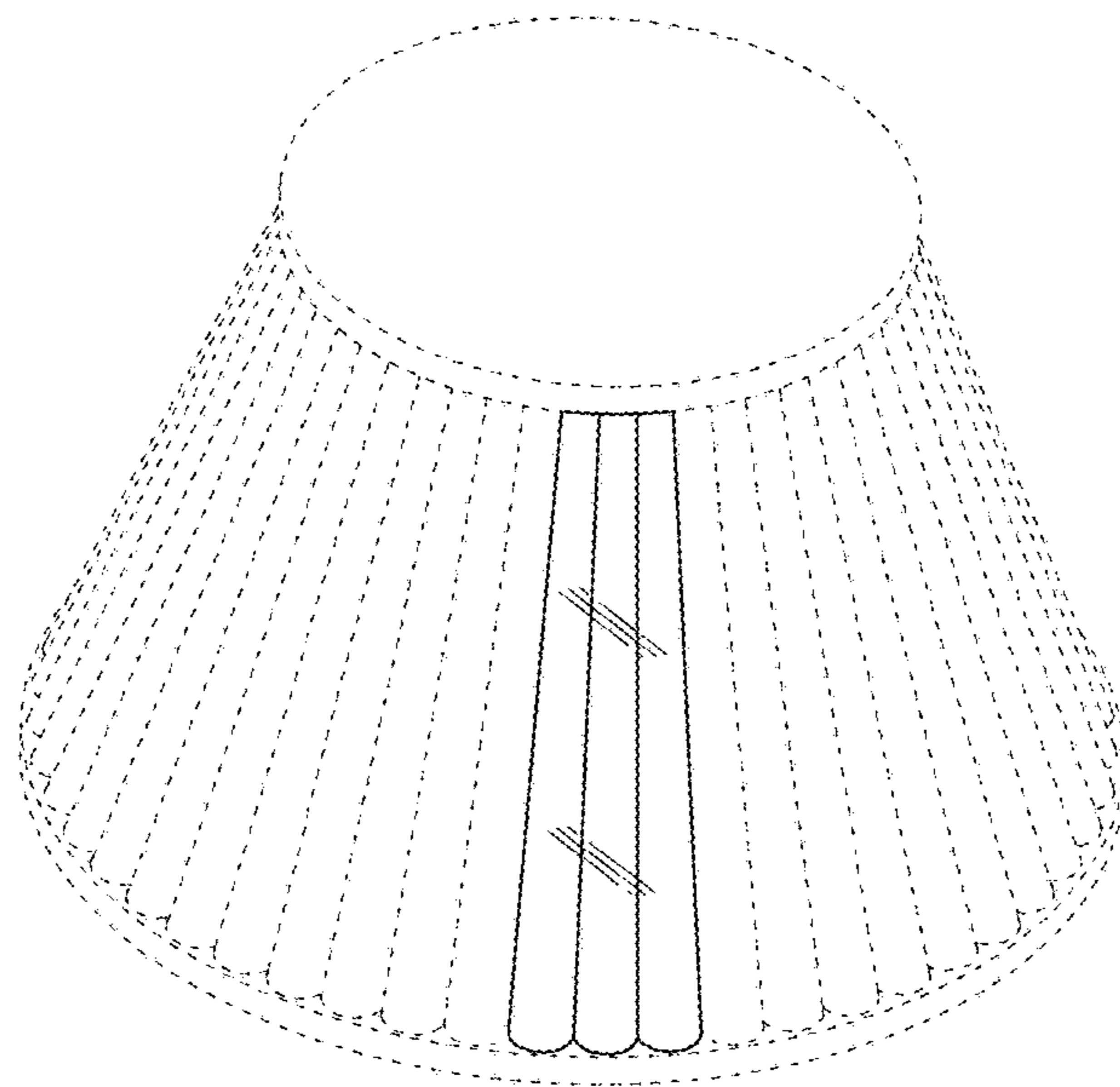

FIG. 9

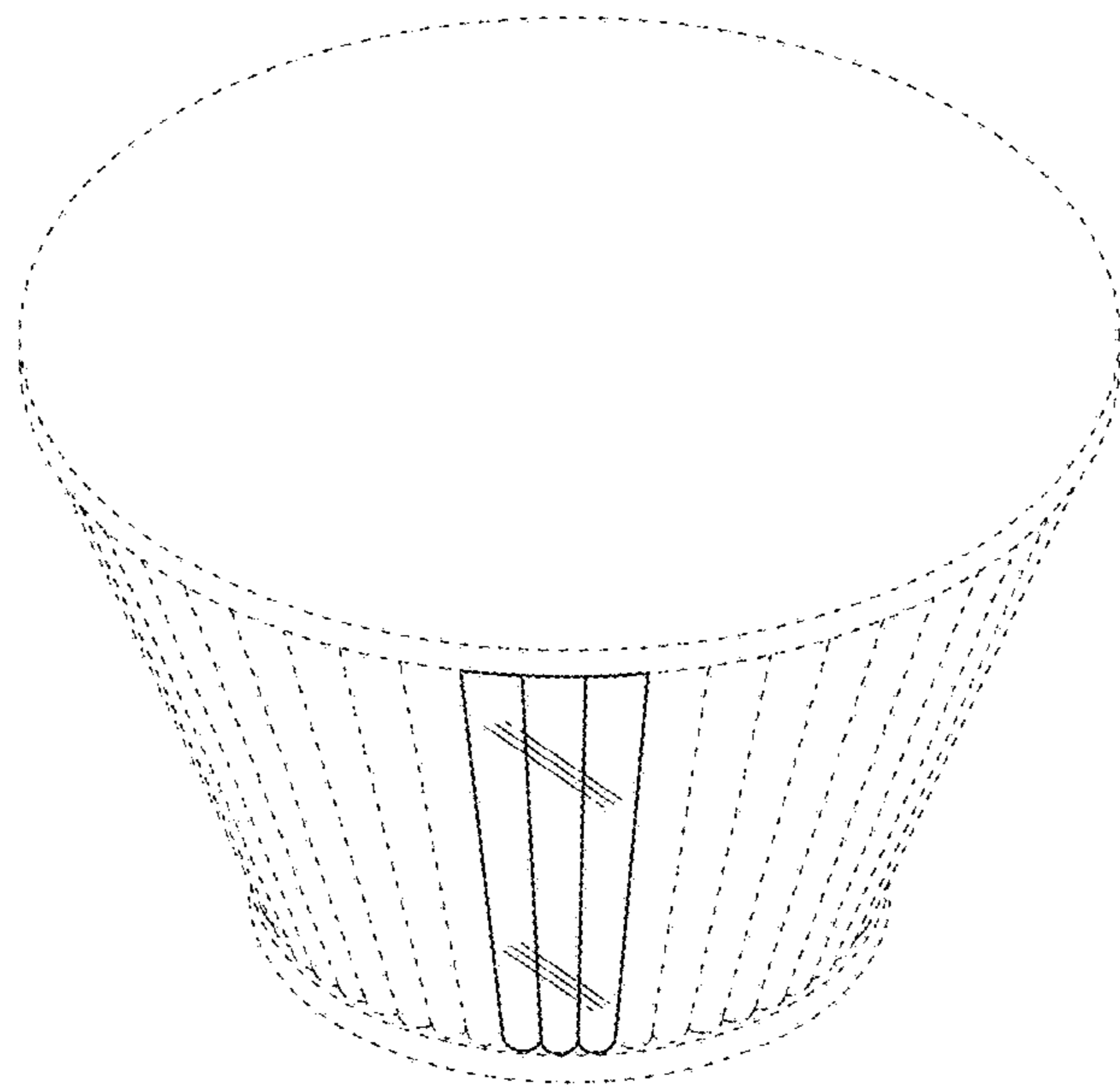

FIG. 10