



US00D835450S

(12) **United States Design Patent**
Prentice et al.

(10) **Patent No.:** **US D835,450 S**

(45) **Date of Patent:** **** Dec. 11, 2018**

(54) **OVEN**

(71) Applicants: **BSH Home Appliances Corporation**,
Irvine, CA (US); **BSH Hausgeräte**
GmbH, Munich (DE)

(72) Inventors: **Ruth Prentice**, Irvine, CA (US);
Andrew Roberson, Long Beach, CA
(US); **Graham Sadtler**, Huntington
Beach, CA (US); **Lucas Taccardi**,
Costa Mesa, CA (US)

(73) Assignees: **BSH Home Appliances Corporation**,
Irvine, CA (US); **BSH Hausgeräte**
GmbH, Munich (DE)

(**) Term: **15 Years**

(21) Appl. No.: **29/608,159**

(22) Filed: **Jun. 20, 2017**

(51) **LOC (11) Cl.** **07-02**

(52) **U.S. Cl.**
USPC **D7/348**

(58) **Field of Classification Search**
USPC D7/339-341, 344, 346-349, 352, 362,
D7/363, 402, 405-409; D8/311, 312,
D8/315, 316; 99/324, 325, 330-339, 342,
99/403

See application file for complete search history.

(56) **References Cited**

U.S. PATENT DOCUMENTS

D646,113 S * 10/2011 Park D7/348
D762,415 S * 8/2016 Chung D7/405

D763,654 S * 8/2016 Chung D8/315
D770,839 S * 11/2016 Shoemaker D7/348
D786,611 S * 5/2017 Funnell, II D7/348
D787,879 S * 5/2017 Kim D7/348
2003/0056334 A1* 3/2003 Finkelstein F24C 15/024
16/436

* cited by examiner

Primary Examiner — Freda S Nunn

(74) *Attorney, Agent, or Firm* — Michael E. Tschupp;
Andre Pallapies; Brandon G. Braun

(57) **CLAIM**

We claim the ornamental design for an oven, as shown and described.

DESCRIPTION

FIG. 1 is a perspective view of an oven, showing our new design;

FIG. 2 is a front elevational view thereof;

FIG. 3 is a rear elevational view thereof;

FIG. 4 is a left side elevational view thereof;

FIG. 5 is a top plan view thereof; and,

FIG. 6 is a bottom plan view thereof.

Broken lines are for illustrating unclaimed portions of the oven and/or for illustrating an environment related to the claimed design; the broken lines form no part of the claimed design. The right side elevational view of the oven is a mirror image of the left side elevational view shown in FIG. 4.

1 Claim, 6 Drawing Sheets

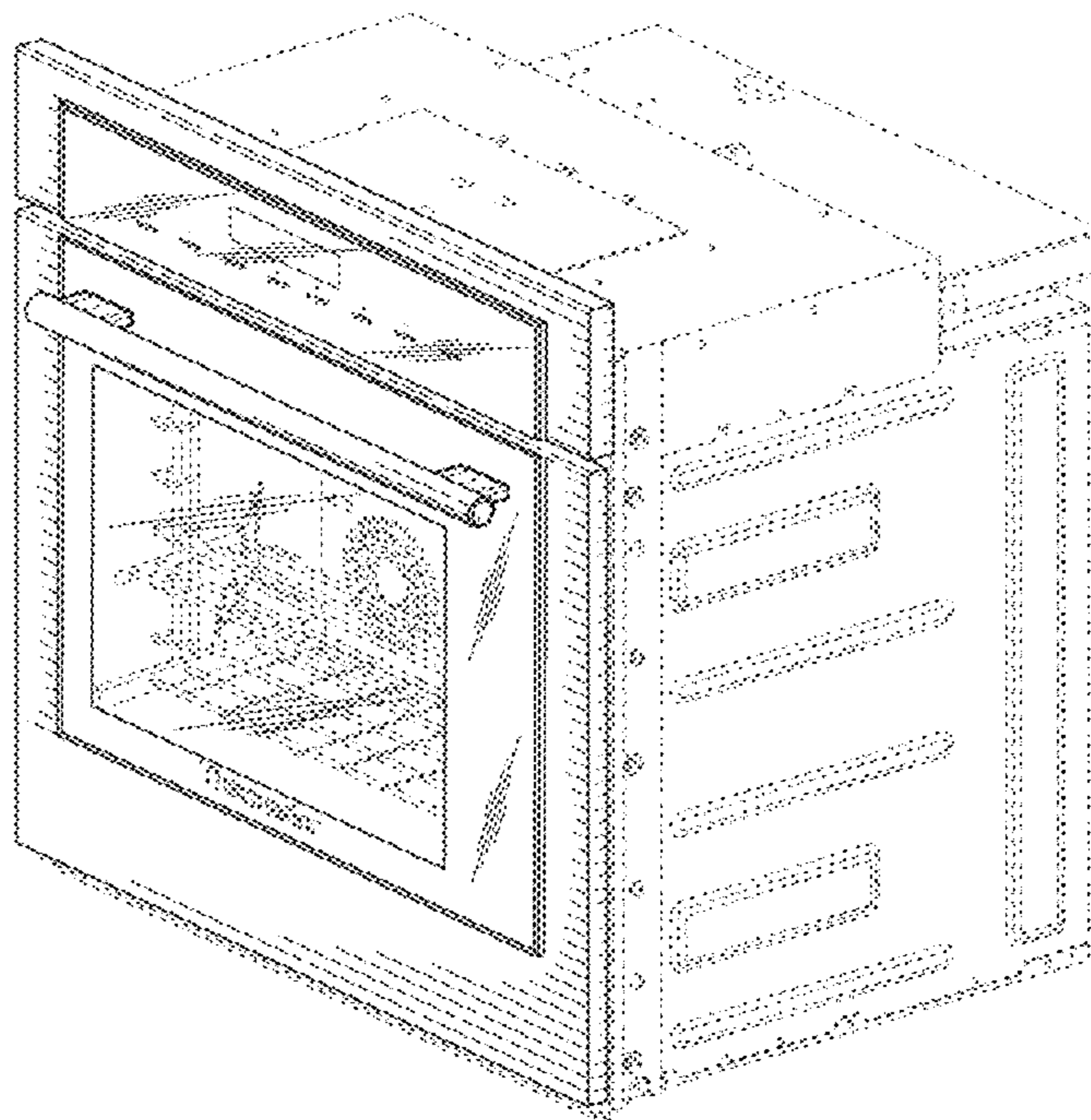

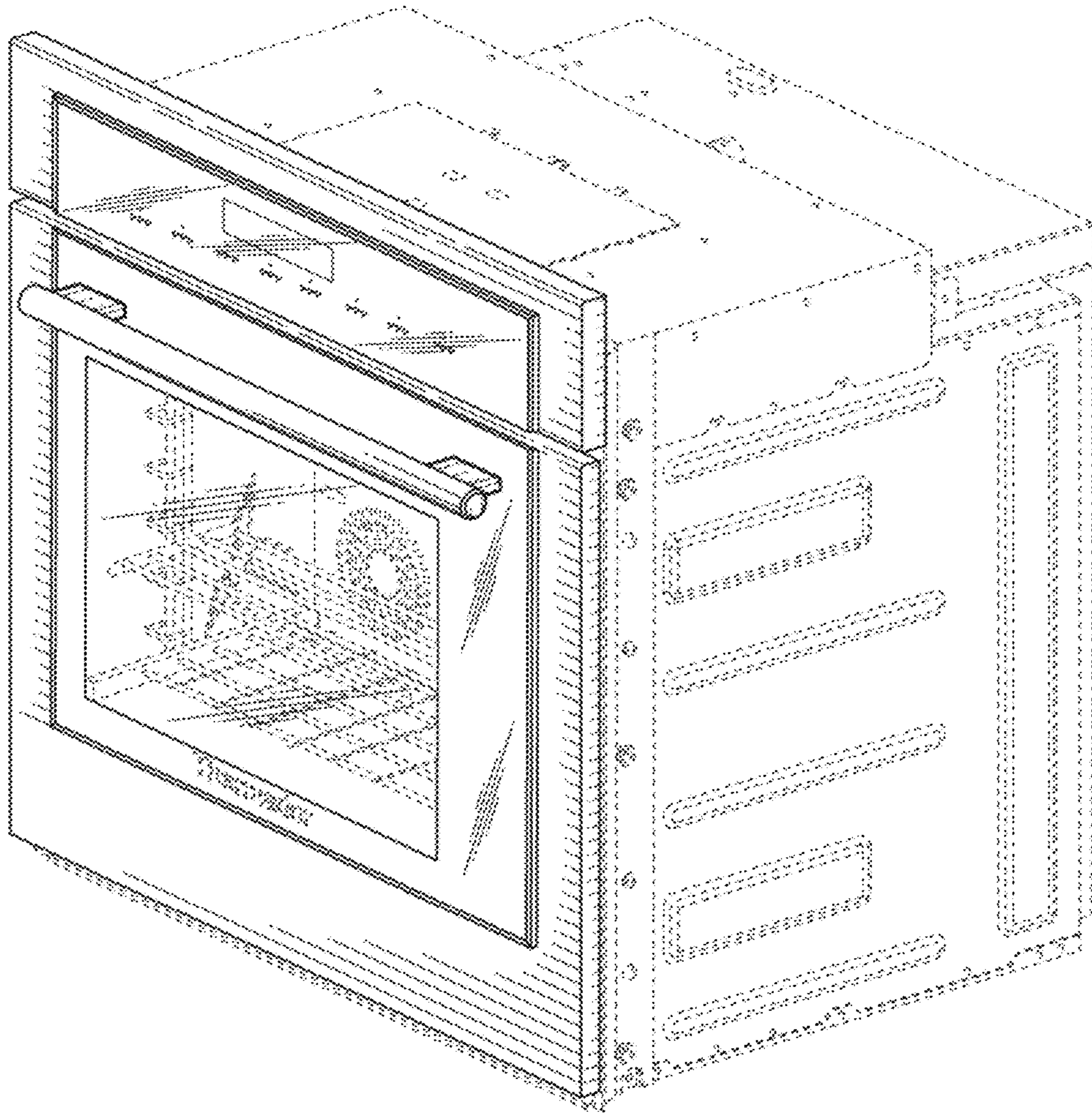

FIG. 1

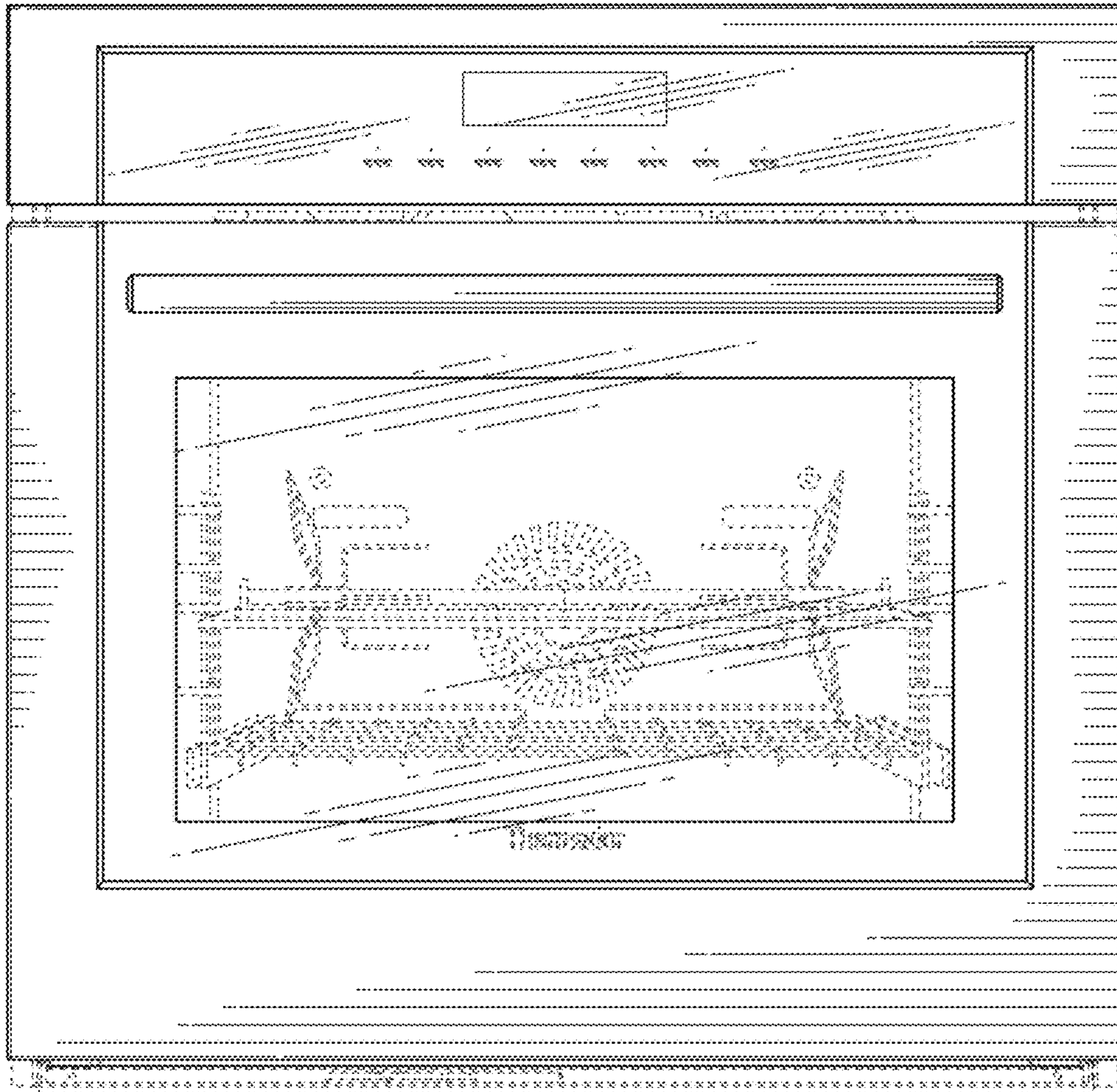

FIG. 2

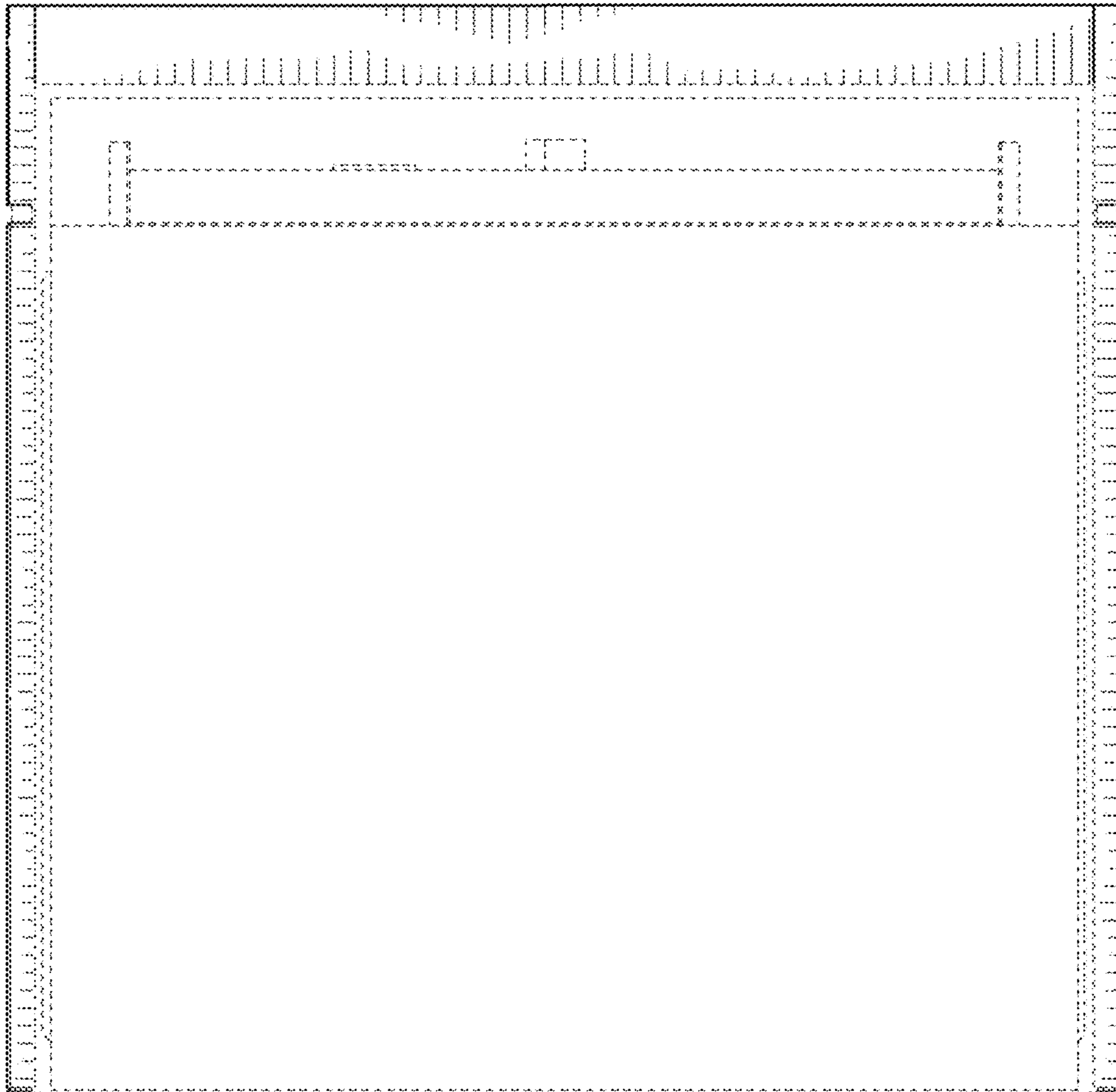

FIG. 3

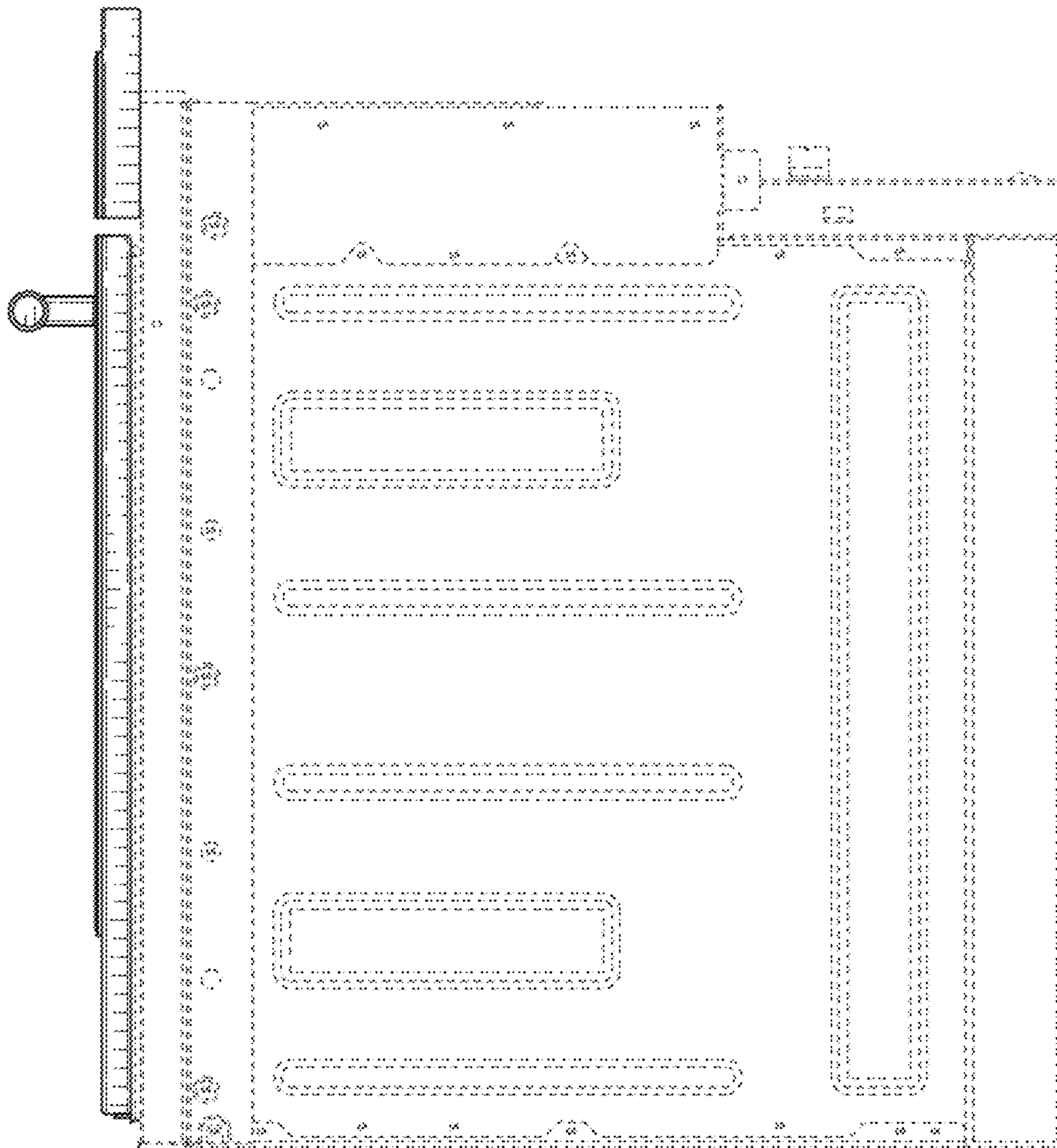

FIG. 4

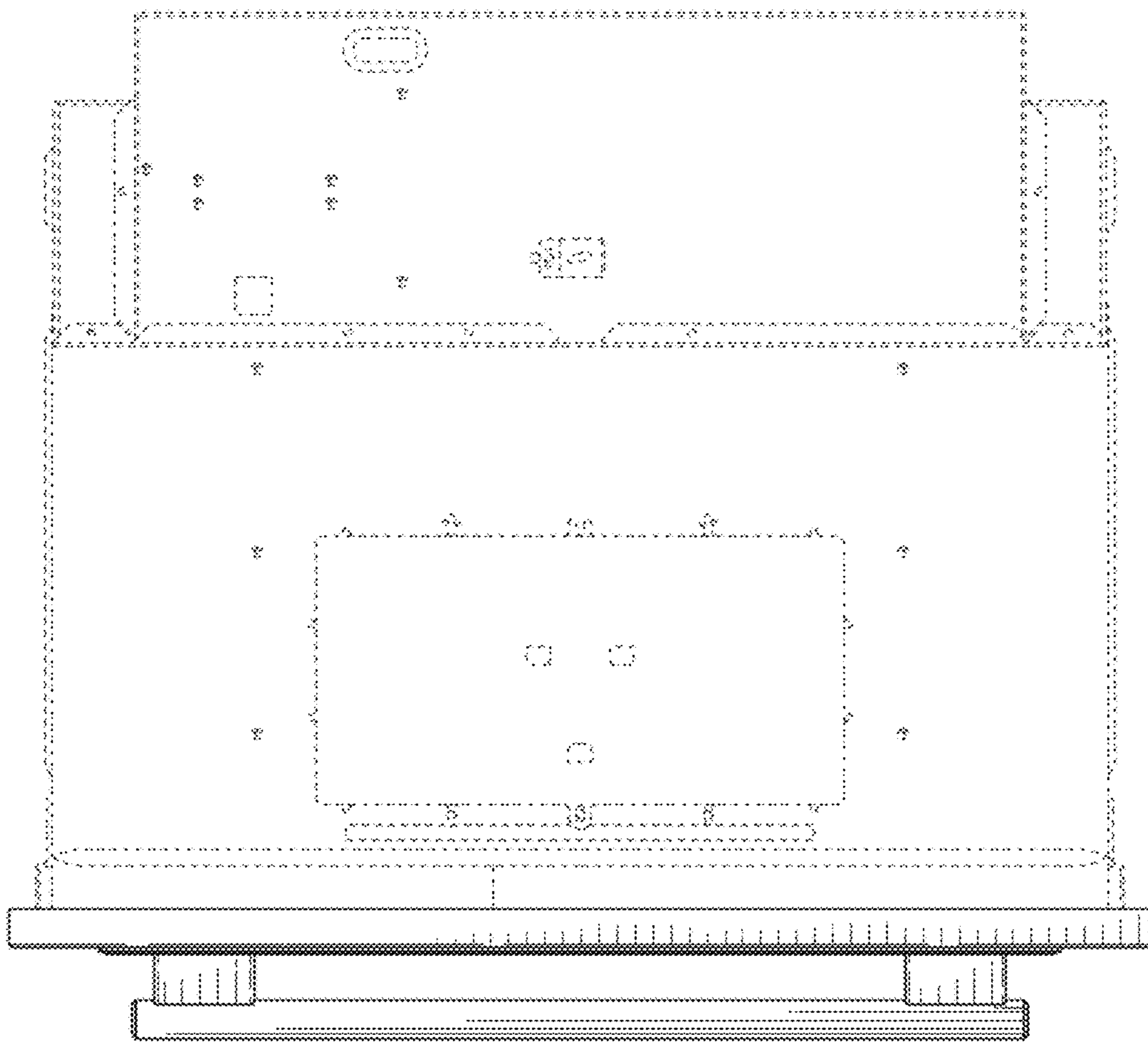

FIG. 5

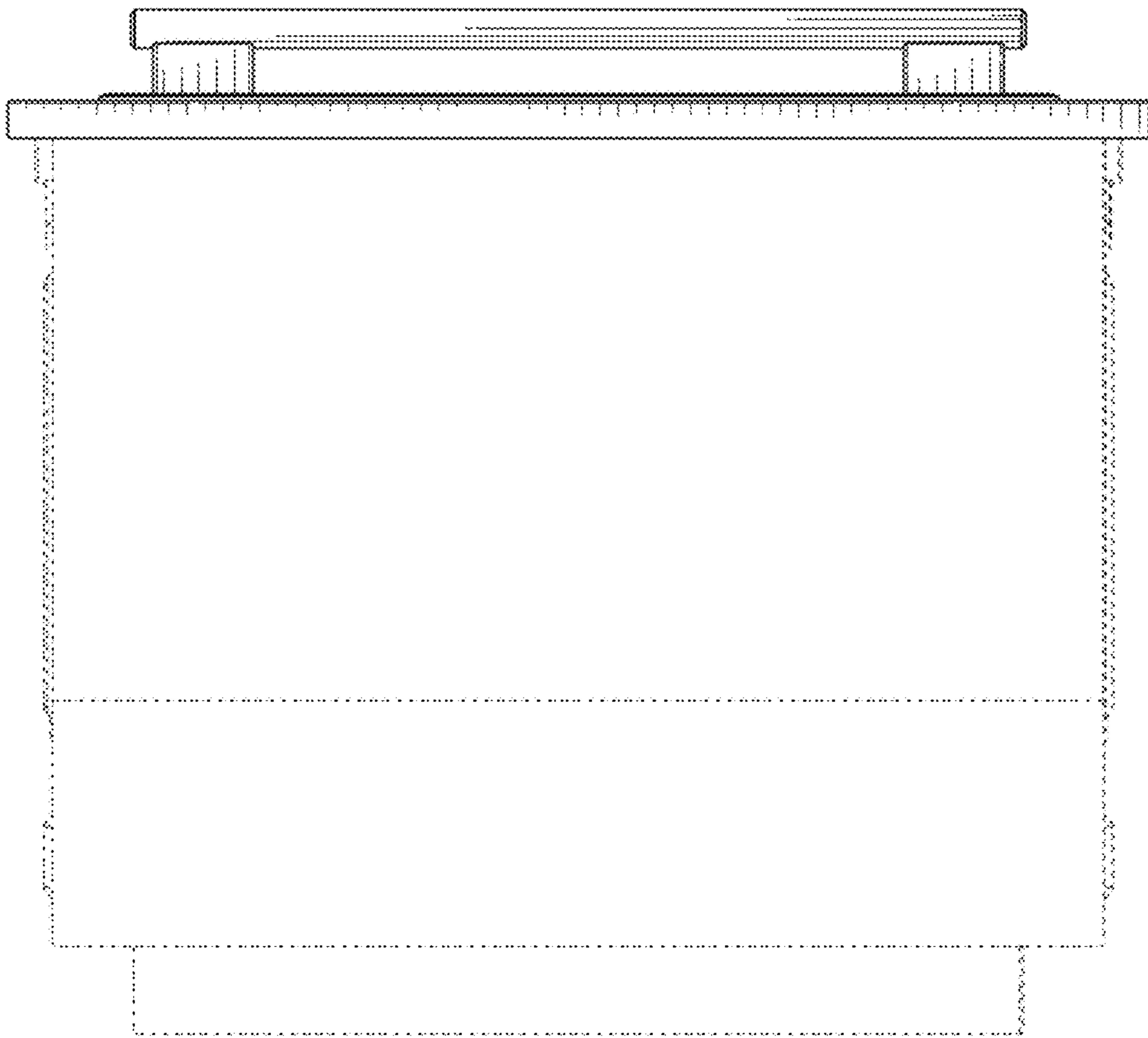

FIG. 6