



US00D835436S

(12) **United States Design Patent**
Reister

(10) **Patent No.:** **US D835,436 S**

(45) **Date of Patent:** **** Dec. 11, 2018**

(54) **COMBINED DRESSER VALET AND CHARGING STATION**

(71) Applicant: **The Modern Gentleman, Inc.**, Dallas, TX (US)

(72) Inventor: **Richard James Reister**, Plano, TX (US)

(73) Assignee: **The Modern Gentleman, Inc.**, Plano, TX (US)

(**) Term: **15 Years**

(21) Appl. No.: **29/610,470**

(22) Filed: **Jul. 12, 2017**

(51) **LOC (11) Cl.** **06-04**

(52) **U.S. Cl.**
USPC **D6/662**

(58) **Field of Classification Search**
USPC D6/384, 515, 662, 663, 667, 671, 671.1, D6/675.1; D3/269, 296, 304, 307, 309; D7/333, 368; D23/286, 343, 342
CPC . A47F 3/043; A47F 7/03; A47F 7/021; A47B 49/004; A47B 88/90; A47B 2095/024; F25D 23/026
See application file for complete search history.

(56) **References Cited**

U.S. PATENT DOCUMENTS

2,564,122	A *	8/1951	Mele	A45C 11/16 220/501
2,697,537	A *	12/1954	Wetherell	A45C 11/16 220/829
2,738,250	A *	3/1956	Mele	A45C 11/16 206/558
2,755,154	A *	7/1956	Mele	A45C 11/16 312/269
5,692,605	A *	12/1997	Lai	A45C 11/16 206/566

D396,004	S *	7/1998	Srinual	D3/294
D417,783	S *	12/1999	Wolf	D3/275
D587,495	S *	3/2009	Levinger	D3/295
D676,259	S *	2/2013	Lu	D6/664
D805,815	S *	12/2017	Leonorovitz	D6/667

* cited by examiner

Primary Examiner — Kevin K Rudzinski

Assistant Examiner — Paul D Bohannon

(74) *Attorney, Agent, or Firm* — Slater Matsil, LLP

(57) **CLAIM**

The ornamental design for a combined dresser valet and charging station, as shown and described.

DESCRIPTION

FIG. 1 is a perspective view of a combined dresser valet and charging station showing the new design in an open position; FIG. 2 is a perspective view, closed position of the combined dresser valet and charging station of FIG. 1; FIG. 3 is a front perspective view, open position of the combined dresser valet and charging station of FIG. 1; FIG. 4 is a front perspective, closed position of the combined dresser valet and charging station of FIG. 1; FIG. 5 is a right side elevational view, open position of the combined dresser valet and charging station of FIG. 1; FIG. 6 is a top plan view, open position of the combined dresser valet and charging station of FIG. 1; FIG. 7 is a back side elevational view, closed position of the combined dresser valet and charging station of FIG. 1; FIG. 8 is a bottom side elevational view, closed position of the combined dresser valet and charging station of FIG. 1; and, FIG. 9 is a left side elevational view, open position of the combined dresser valet and charging station of FIG. 1. In FIGS. 1-9 the broken-line disclosure of elements is understood to represent portions of the article in which the design is embodied, but which form no part of the claimed design.

1 Claim, 8 Drawing Sheets

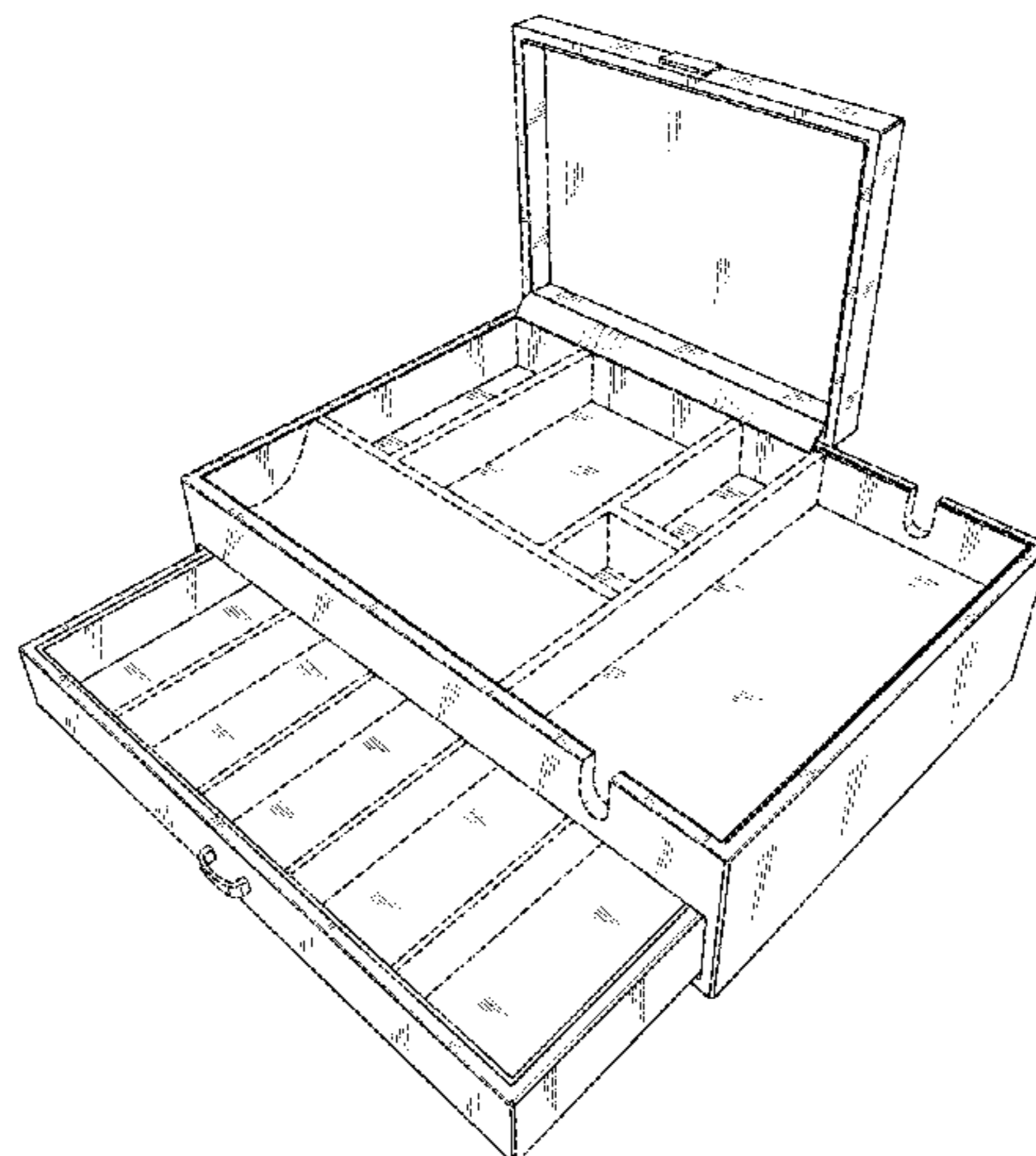

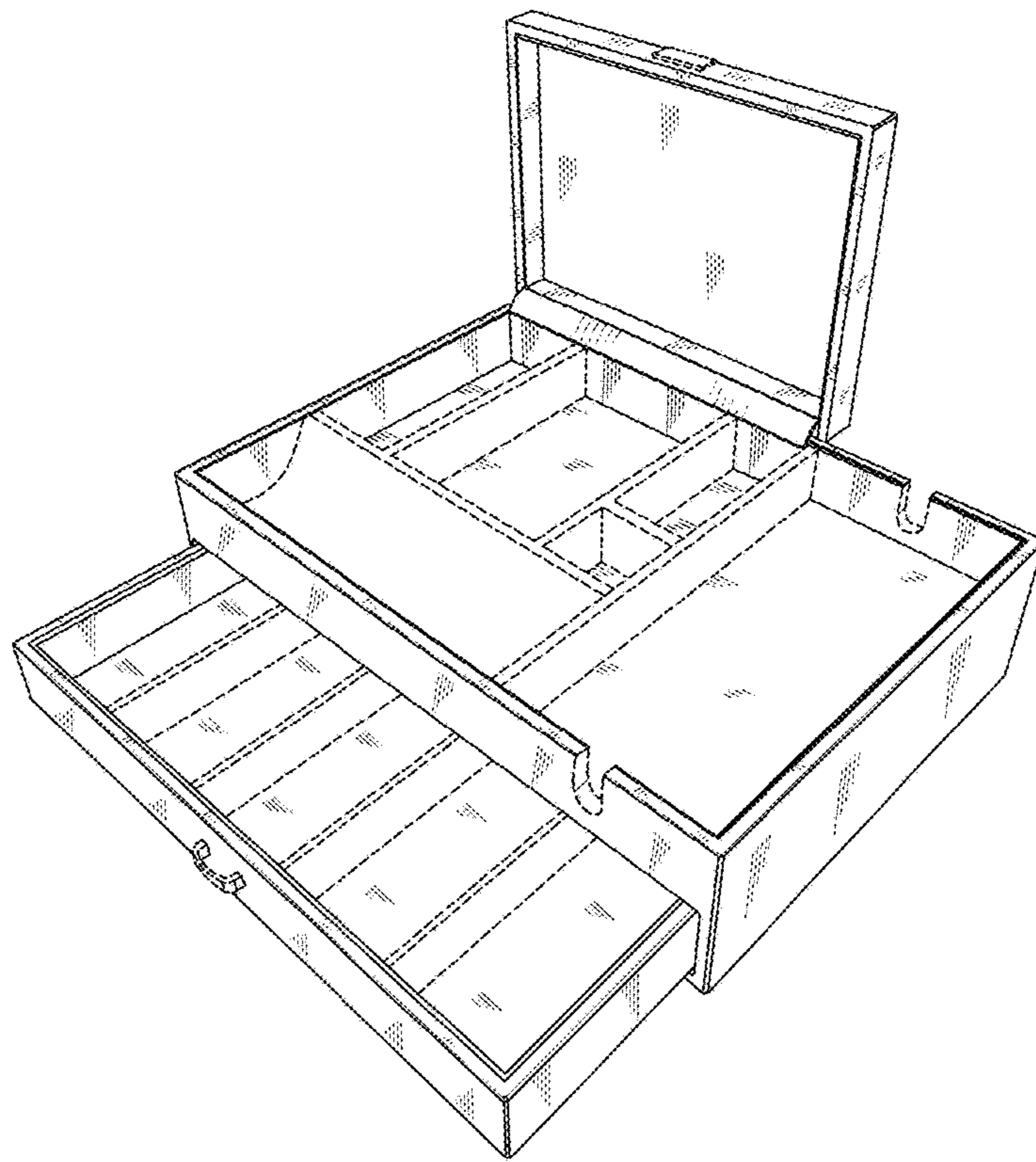

FIG. 1

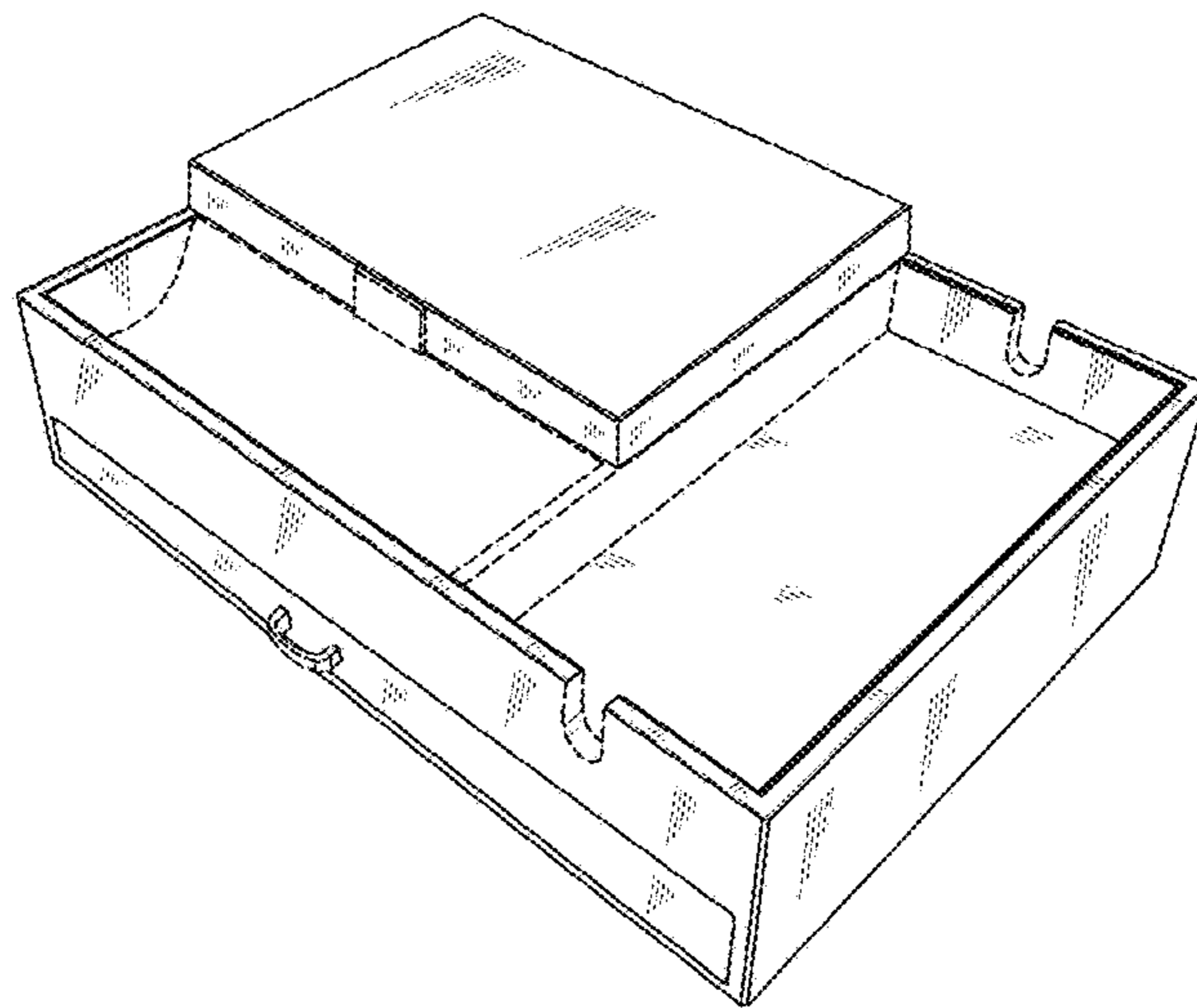

FIG. 2

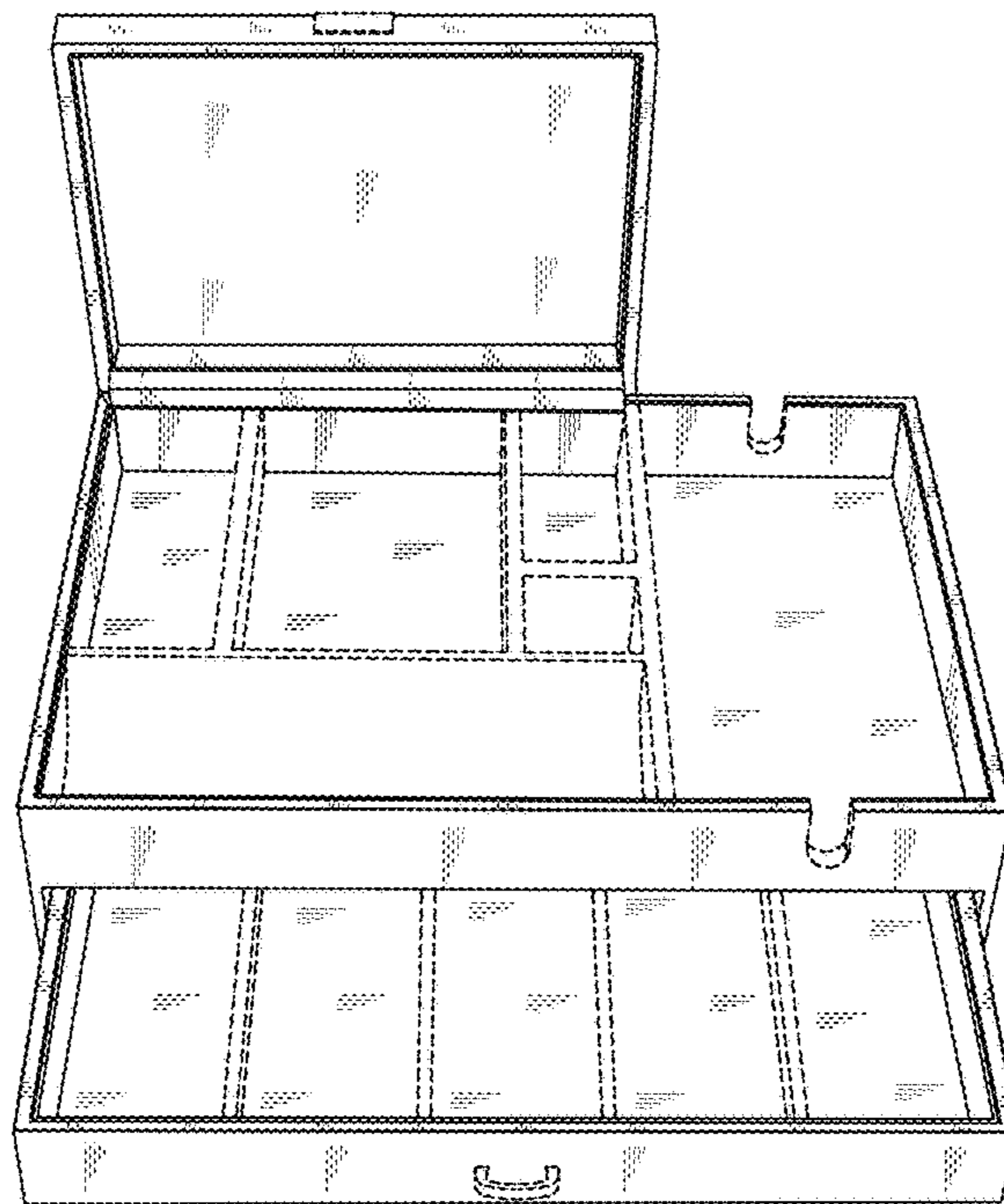

FIG. 3

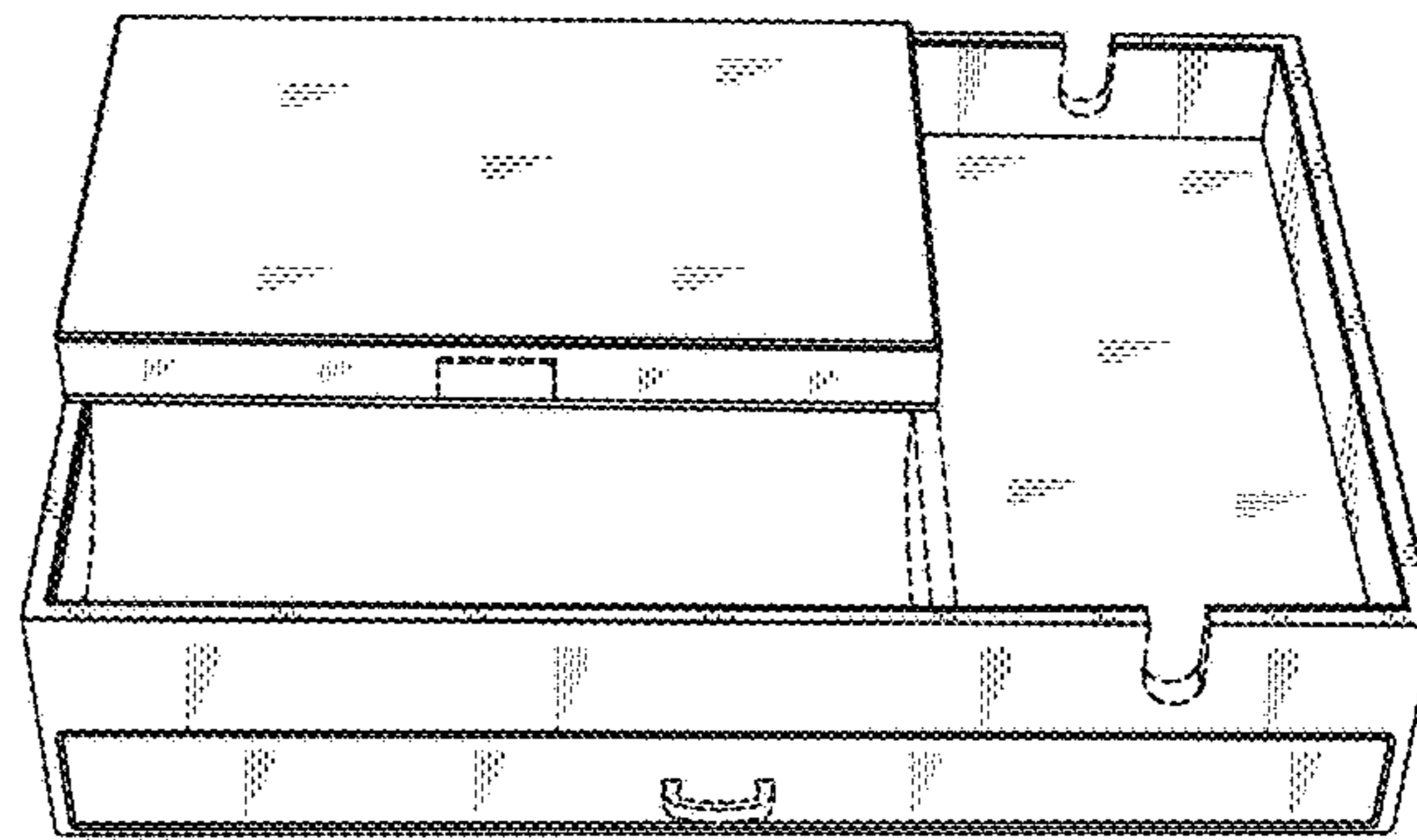

FIG. 4

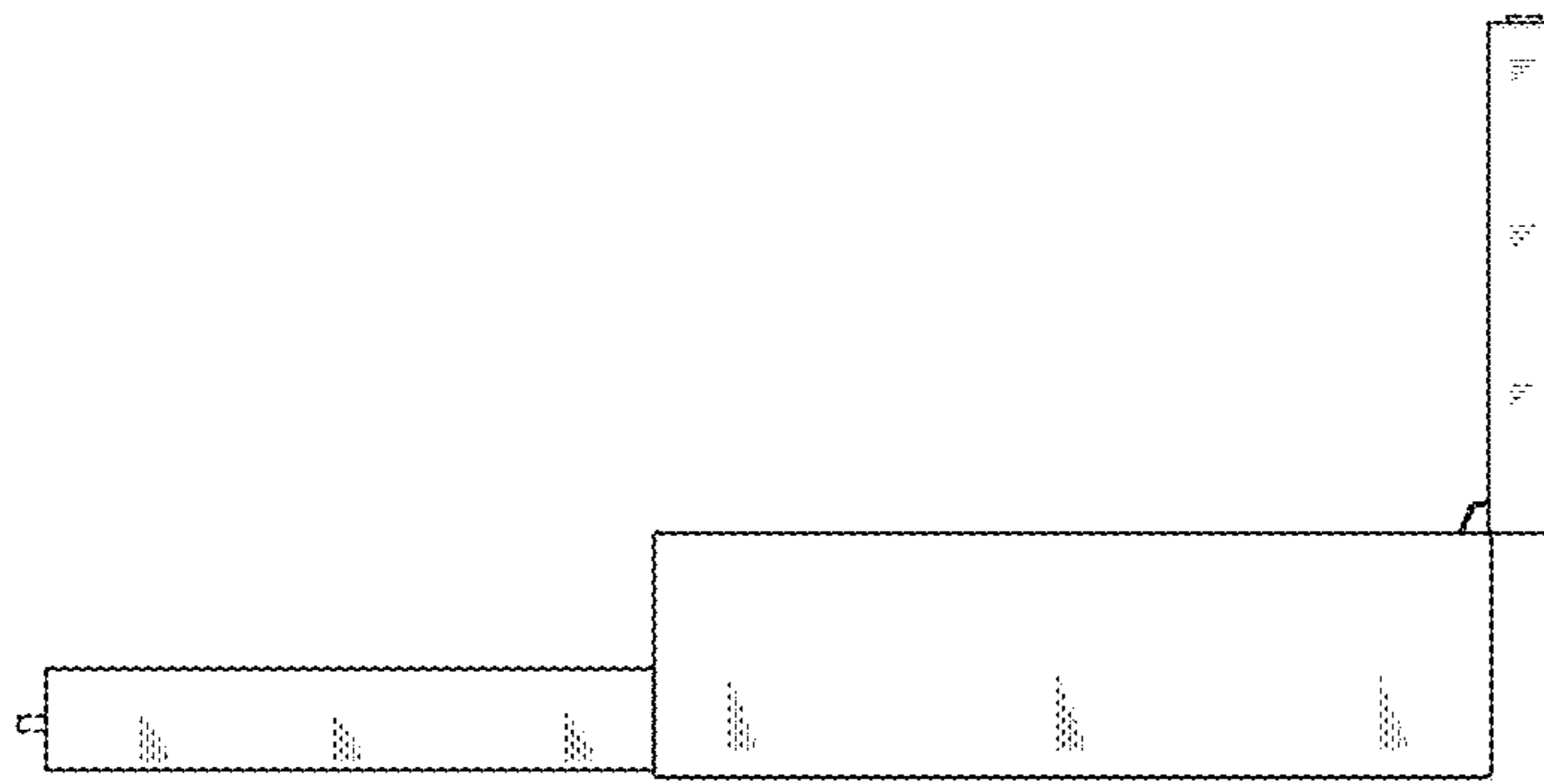

FIG. 5

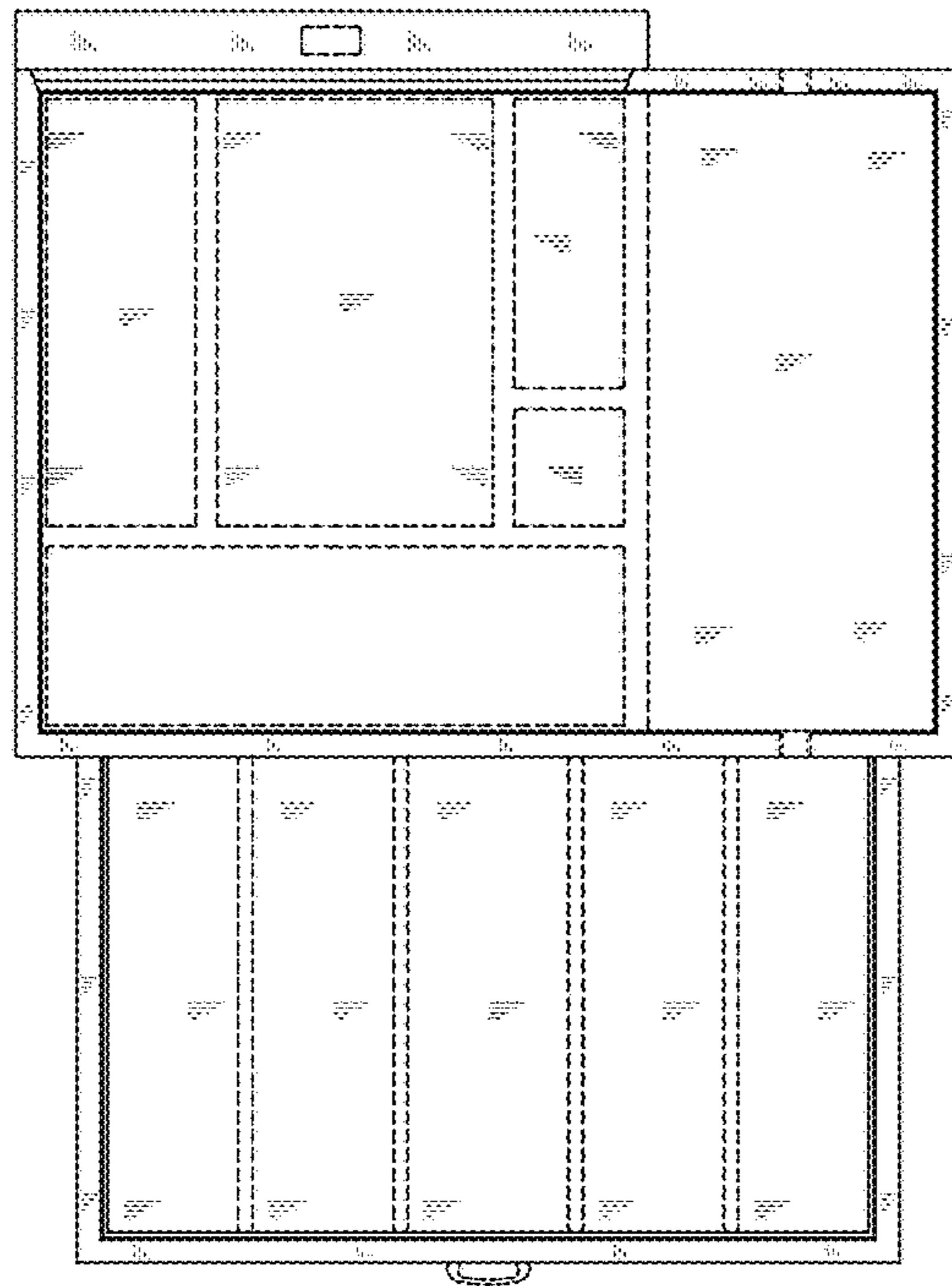

FIG. 6

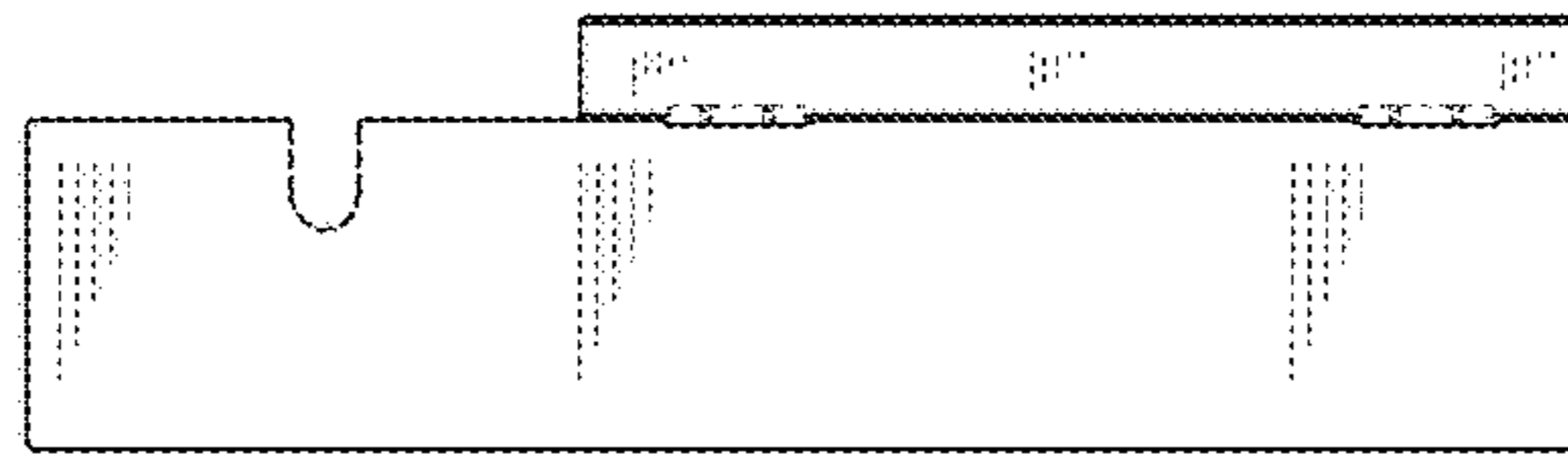

FIG. 7

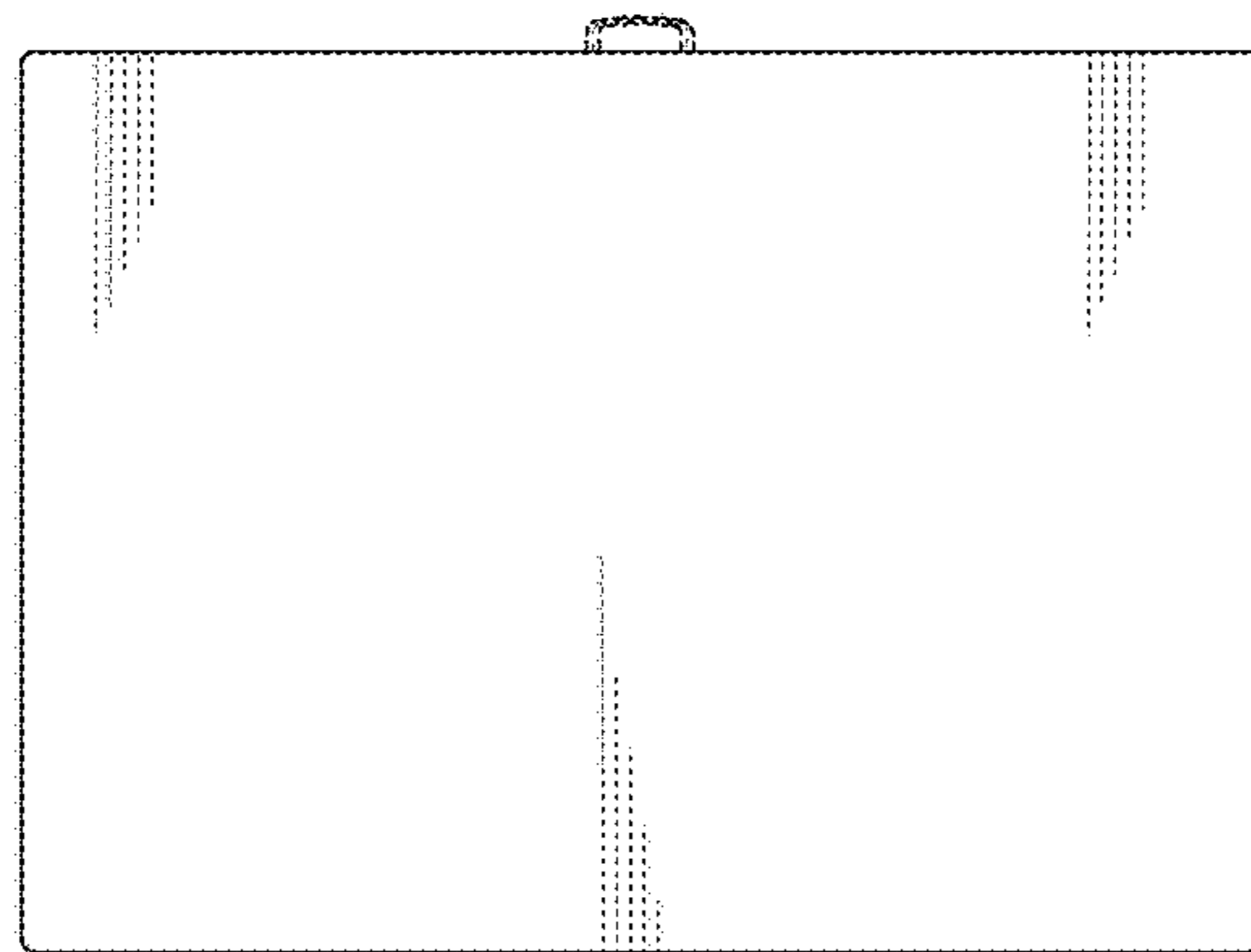

FIG. 8

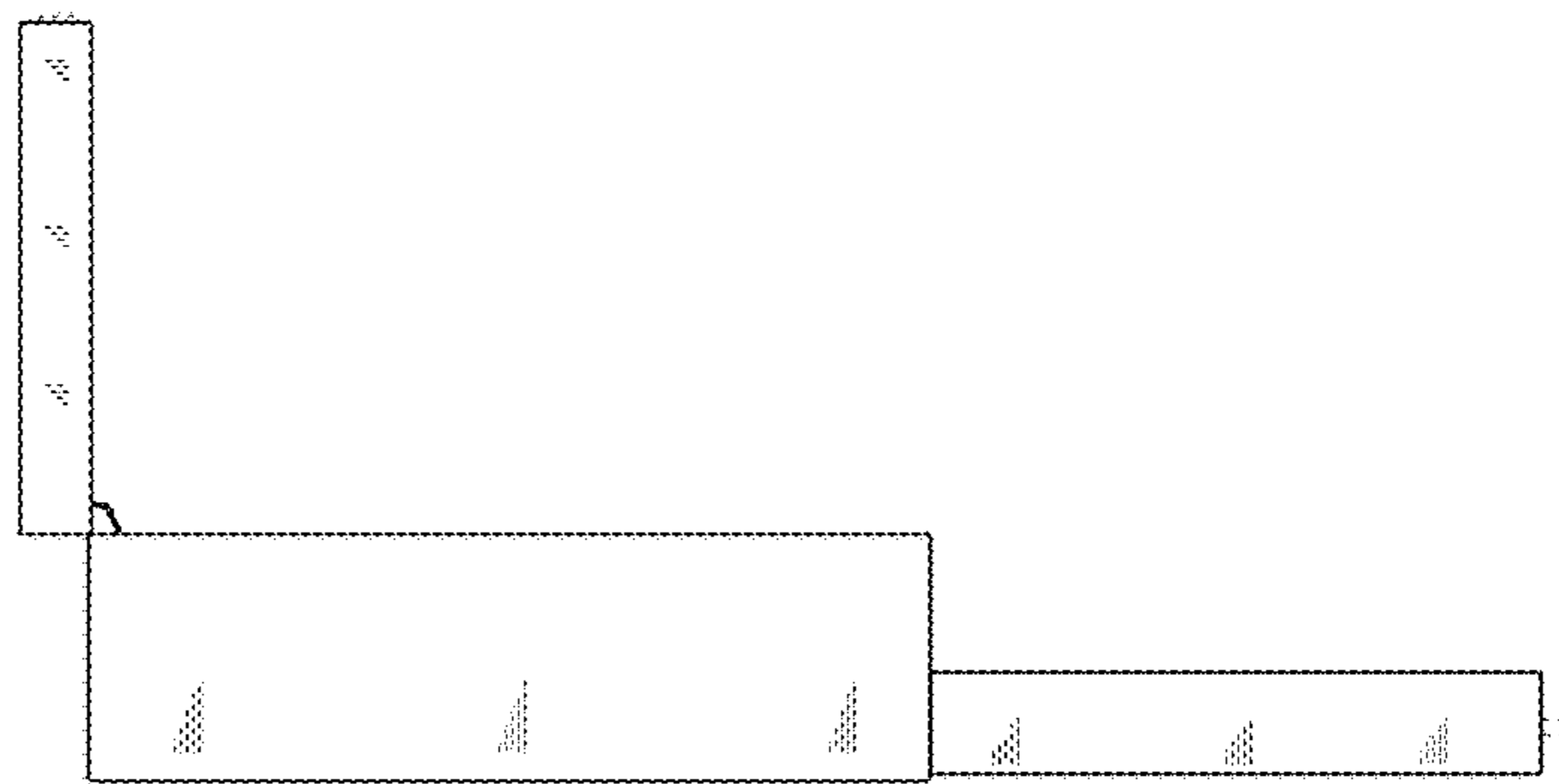

FIG. 9