



US00D835281S

(12) **United States Design Patent**
Clifford et al.

(10) **Patent No.:** **US D835,281 S**

(45) **Date of Patent:** **** Dec. 4, 2018**

(54) **MULTIMODE SURGICAL CONSOLE**

(74) *Attorney, Agent, or Firm* — Howard & Howard
Attorneys PLLC

(71) Applicant: **Stryker Corporation**, Kalamazoo, MI
(US)

(72) Inventors: **Steven Thomas Clifford**, Byron Center,
MI (US); **David Robert Boboltz**,
Kalamazoo, MI (US)

(57) **CLAIM**

The ornamental design for a multimode surgical console, as
shown and described.

(73) Assignee: **STRYKER CORPORATION**,
Kalamazoo, MI (US)

DESCRIPTION

(**) Term: **15 Years**

(21) Appl. No.: **29/602,202**

(22) Filed: **Apr. 28, 2017**

(51) **LOC (11) Cl.** **24-01**

(52) **U.S. Cl.**
USPC **D24/185**

(58) **Field of Classification Search**
USPC D24/185–186, 170, 172, 158
CPC G01N 2035/00306; G01N 2035/00326;
G01N 2035/00336; G01N 2030/027;
A61B

(Continued)

(56) **References Cited**

U.S. PATENT DOCUMENTS

D359,353 S * 6/1995 Butter D24/144
D380,550 S * 7/1997 Dennewill D24/111
6,017,354 A 1/2000 Culp et al.

(Continued)

OTHER PUBLICATIONS

Stryker's MultiGen 2RF Generator . . . , posted at medgadget.com,
posted Jul. 20, 2017, online, URL:<https://www.medgadget.com/2017/07/strykers-multigen-2rf-generator-facet-joint-ablations-cleared-fda.html> (Year: 2018).*

(Continued)

Primary Examiner — Anhdao Doan
Assistant Examiner — Mary Shannon Malley

1 Claim, 14 Drawing Sheets

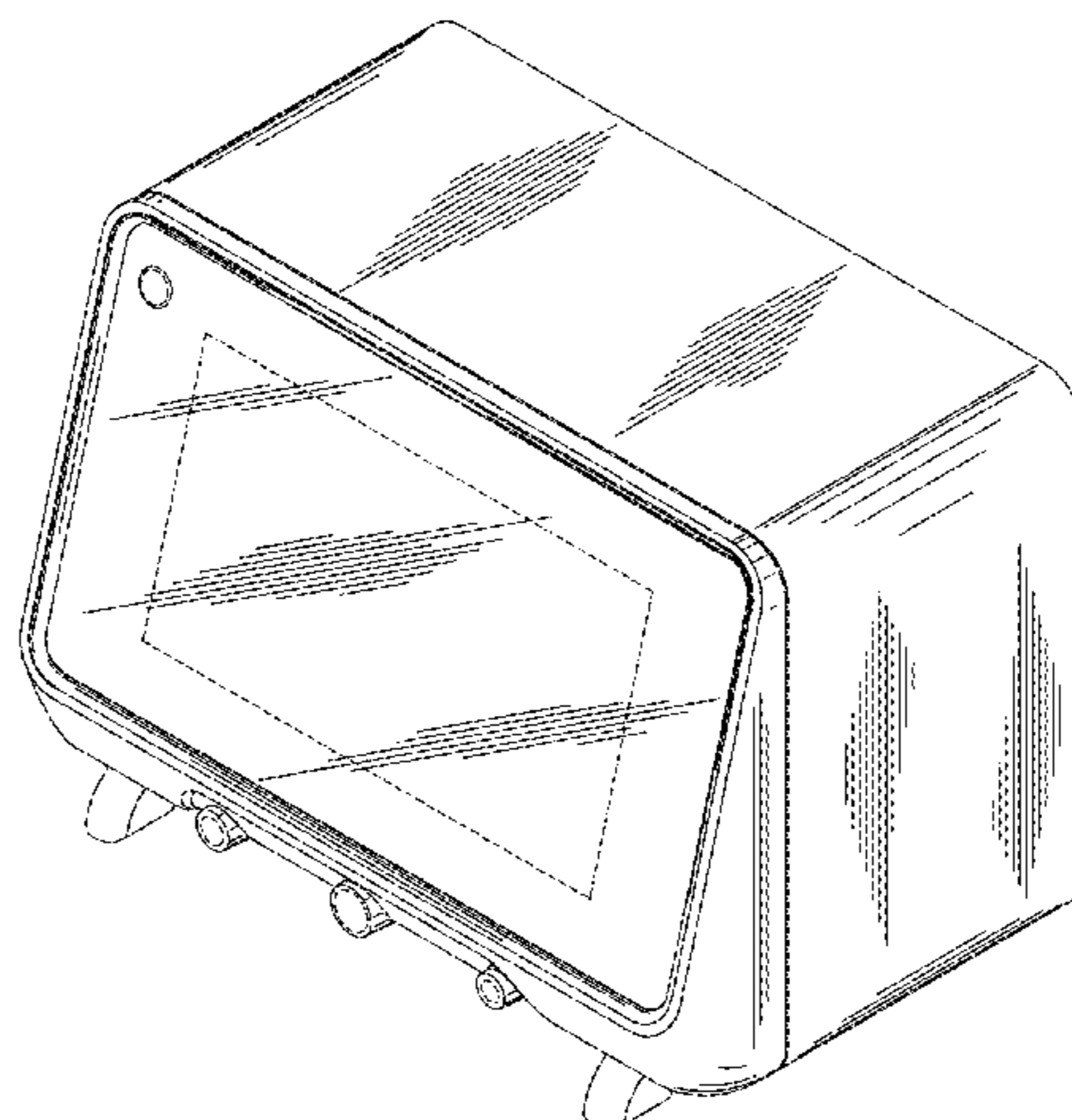

(58) **Field of Classification Search**
 CPC 2017/00973; A61B 2017/00115; A61B
 2017/00199; A61B 2017/00225
 See application file for complete search history.

(56) **References Cited**

U.S. PATENT DOCUMENTS

6,329,778	B1	12/2001	Culp et al.	
6,623,423	B2	9/2003	Sakurai et al.	
6,752,816	B2	6/2004	Culp et al.	
7,217,269	B2	5/2007	El-Galley et al.	
D552,241	S *	10/2007	Bromley	D24/170
D592,754	S *	5/2009	Koike	D24/186
D598,551	S *	8/2009	Miwa	D24/186
7,632,079	B2 *	12/2009	Hershberger	A61B 17/32002 417/477.2
7,918,852	B2 *	4/2011	Tullis	A61B 18/1477 606/41
D689,195	S *	9/2013	Nelsen	D24/107
D704,839	S *	5/2014	Juzkiw	D24/170
D728,121	S *	4/2015	Cook	D24/216
D734,475	S *	7/2015	Ross	D24/185
D735,865	S *	8/2015	Nishimura	D24/164
D775,734	S *	1/2017	Hrenchir	D24/170

OTHER PUBLICATIONS

Stryker Corporation, Instruments Division, "Consolidated Operating Room Equipment—Powered Instrument Driver REF 5400050—Instructions for Use", May 2005, pp. 1-38.

Stryker Corporation, "CORE Console-Features and Benefits", 2017, pp. 1-5.
 Stryker Corporation, "Powered Instrument Driver", 2017, 2 pages.
 Soma Technology, Inc., "The Stryker MultigGen Radiofrequency Generator", Apr. 16, 2014, 2 pages.
 Stryker Corporation, "SONOPET Ultrasonic Aspirator Equipment Guide", 2016, 4 pages.
 Stryker Corporation, "SONOPET Ultrasonic Aspirator ProCare Service", 2016, 2 pages.
 Stryker Corporation, "SONOPET Ultrasonic Aspirator—Features and Benefits", 2017, 5 pages.
 Stryker Corporation, "The Complete Guide to SONOPET", 2016, 12 pages.
 Stryker Corporation, "SONOPET Ultrasonic Aspirator Product Catalog", 2016, pp. 1-19.
 Youtube, "Stryker Multi-Gen Monopolar Procedure Animation", https://www.youtube.com/watch?v=TuIVN_O-xDk, Sep. 28, 2009, 3 pages.
 Youtube, "Stryker 9100001425 Sonopet Setup Video", <https://www.youtube.com/watch?v=xkAooHgdjuY>, Dec. 20, 2013, 3 pages.
 Youtube, "Stryker CORE Powered Instrument Driver", <https://www.youtube.com/watch?v=CroEOeQbXs8>, Sep. 5, 2014, 3 pages.
 Youtube, "Stryker CORE w/Sumex Hand Piece", <https://www.youtube.com/watch?v=0kEbMx6NA3M>, May 13, 2016, 3 pages.

* cited by examiner

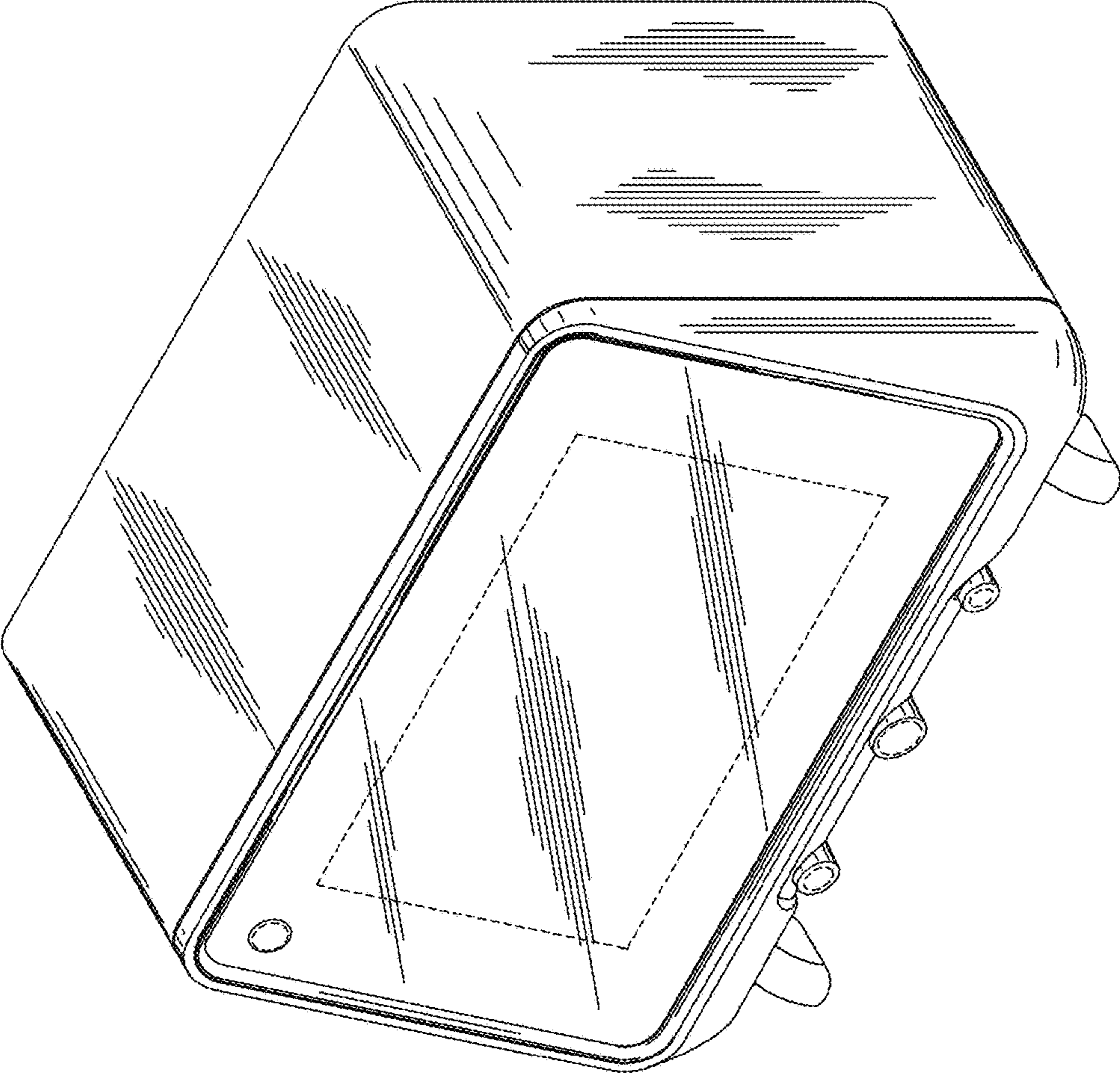

FIG. 1

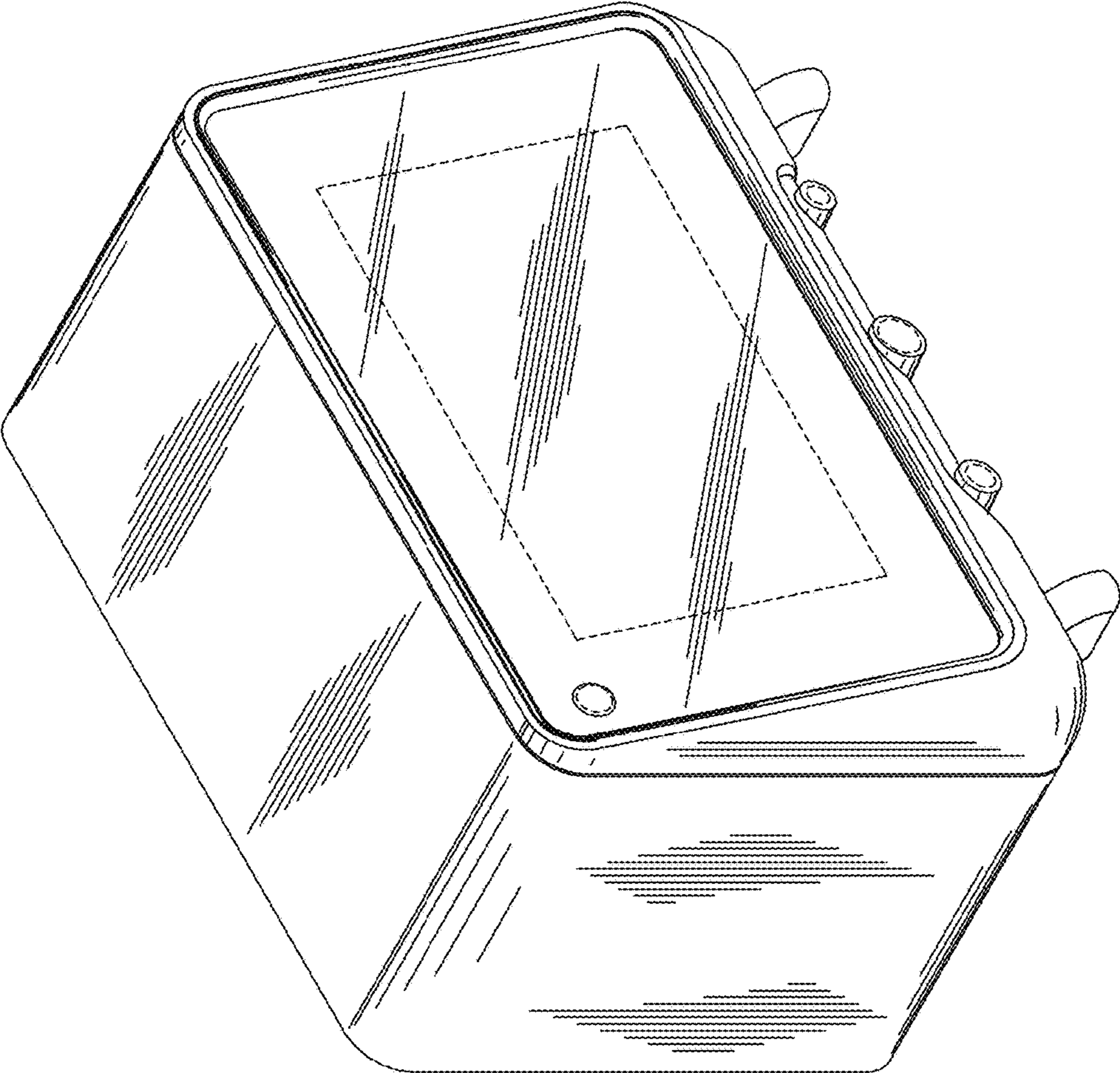

FIG. 2

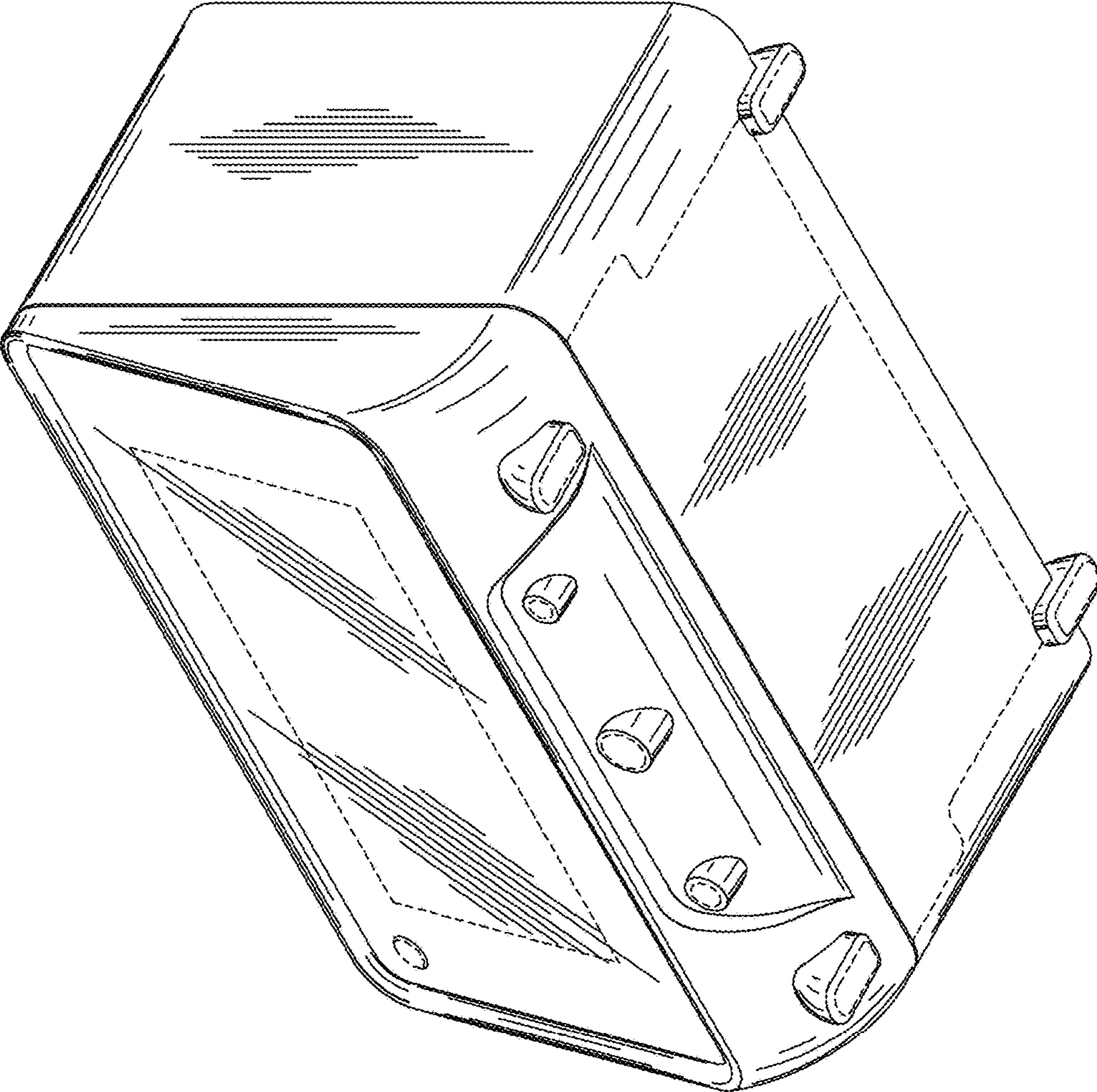

FIG. 3

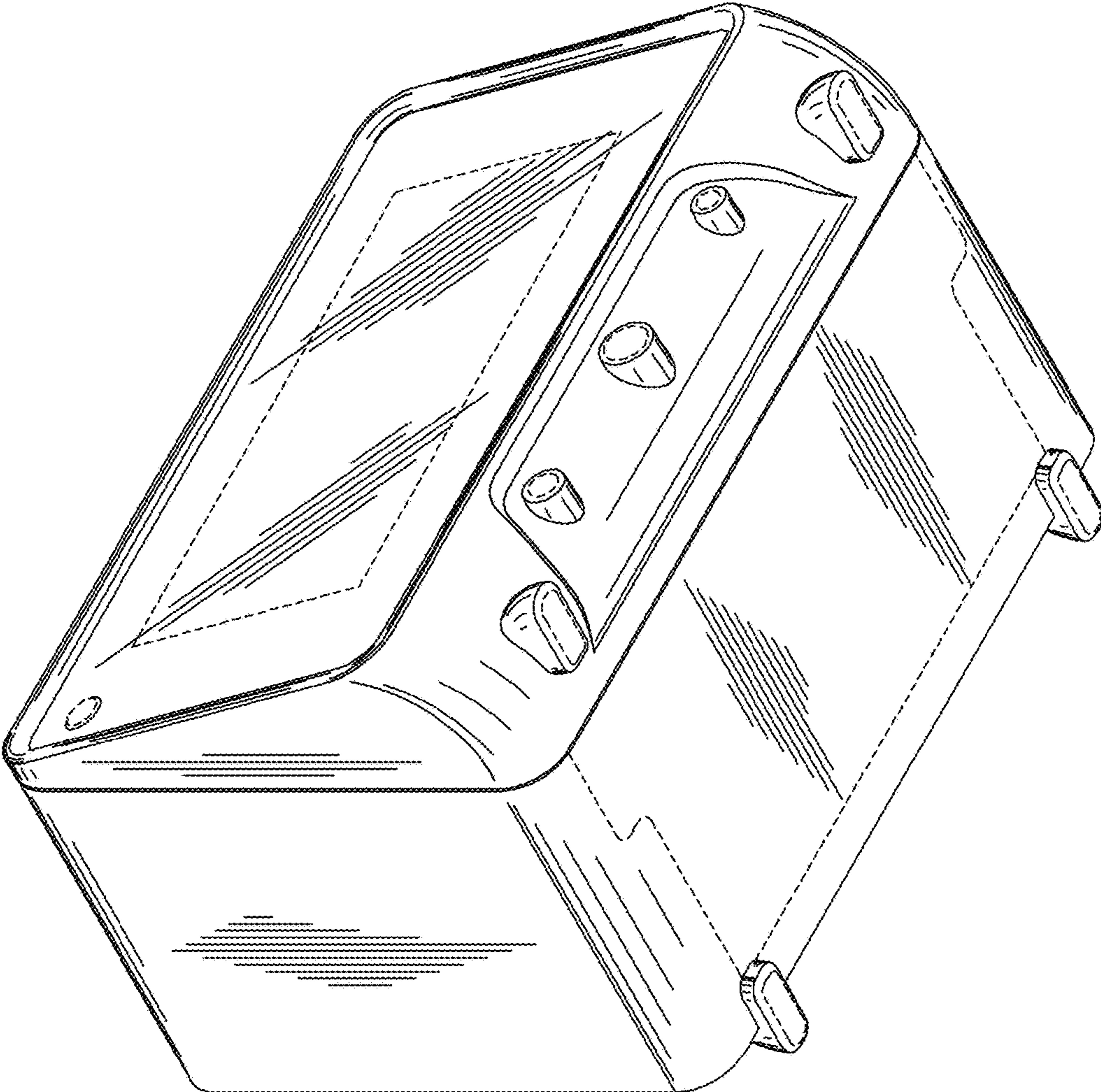

FIG. 4

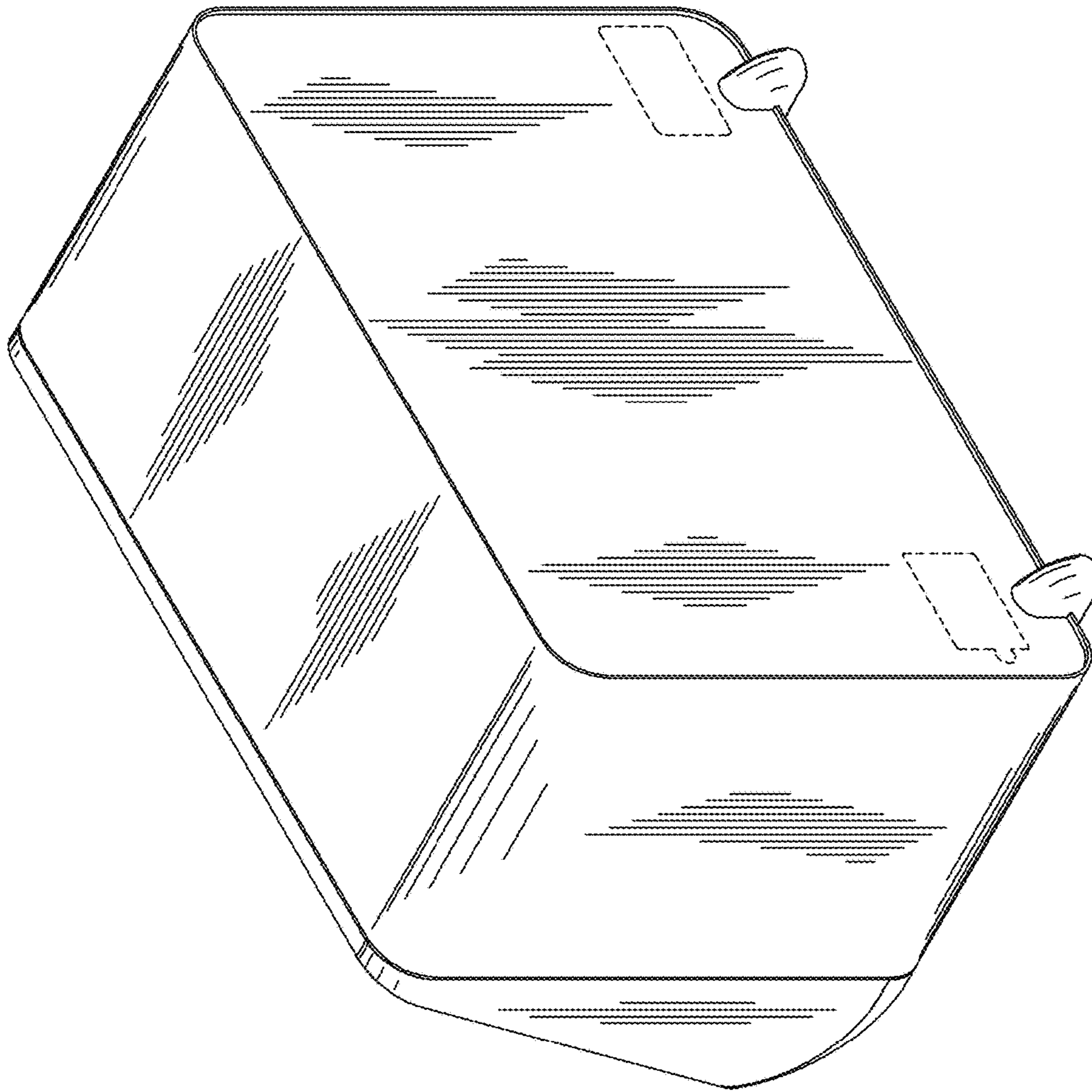

FIG. 5

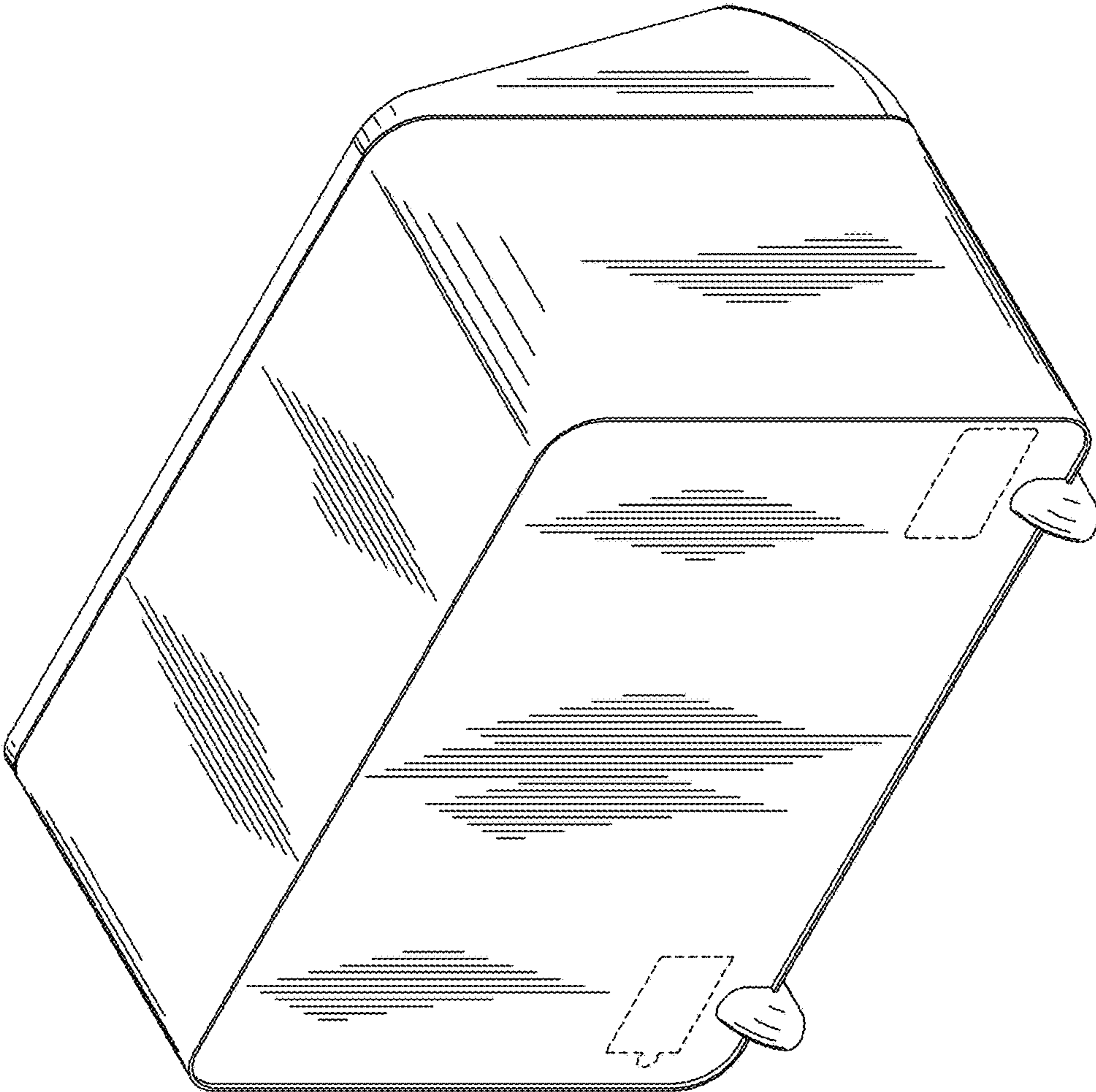

FIG. 6

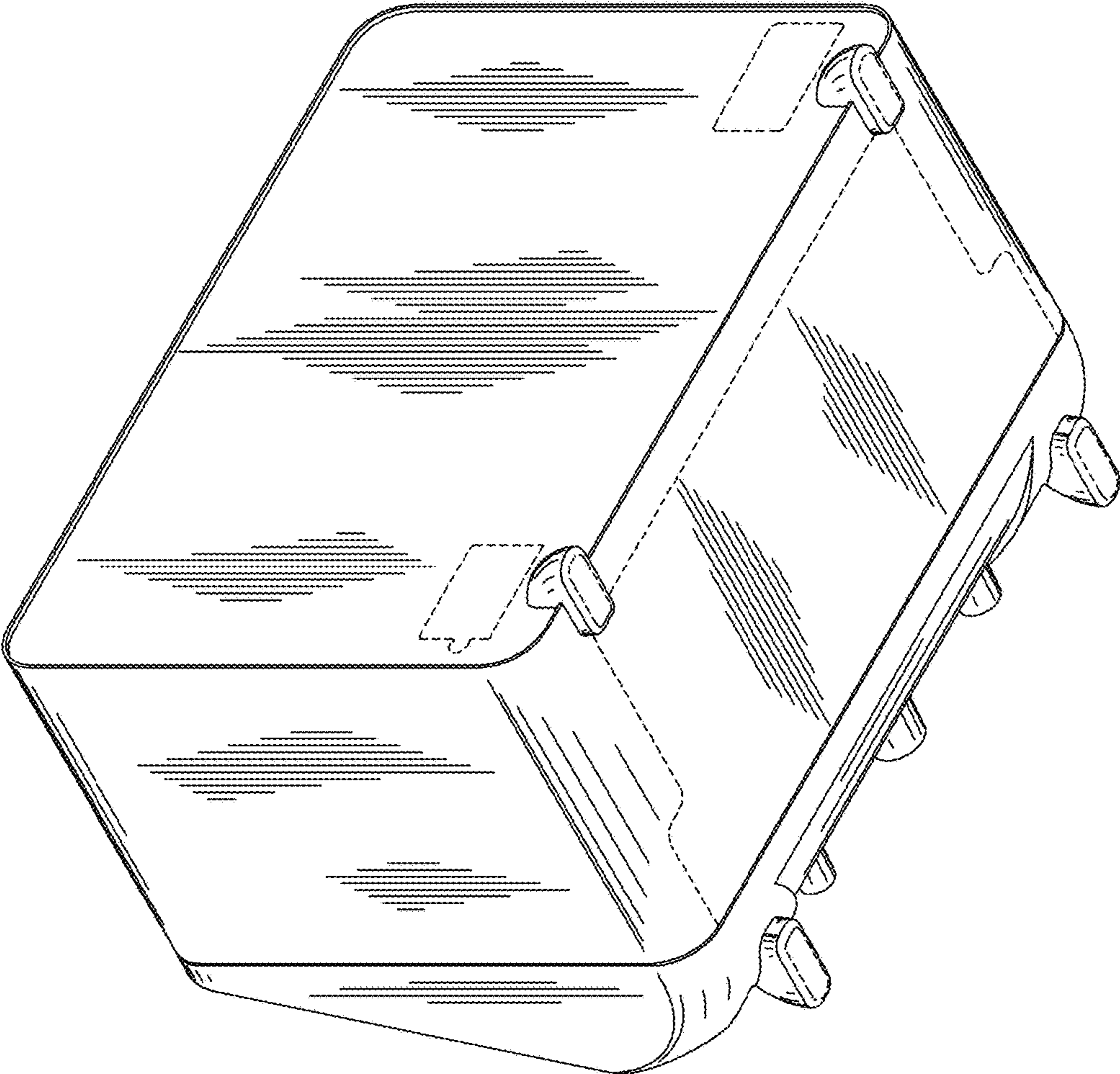

FIG. 7

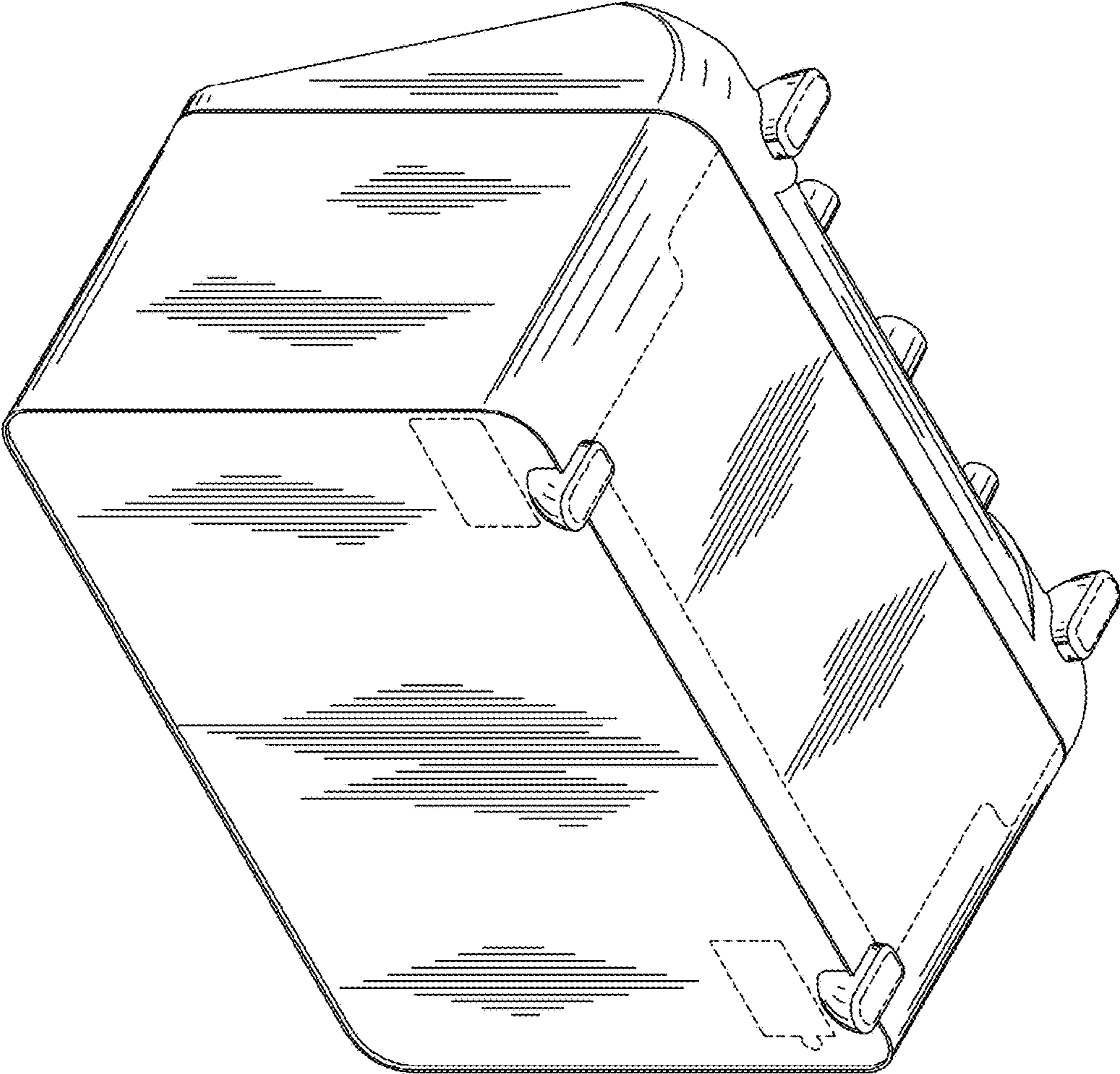

FIG. 8

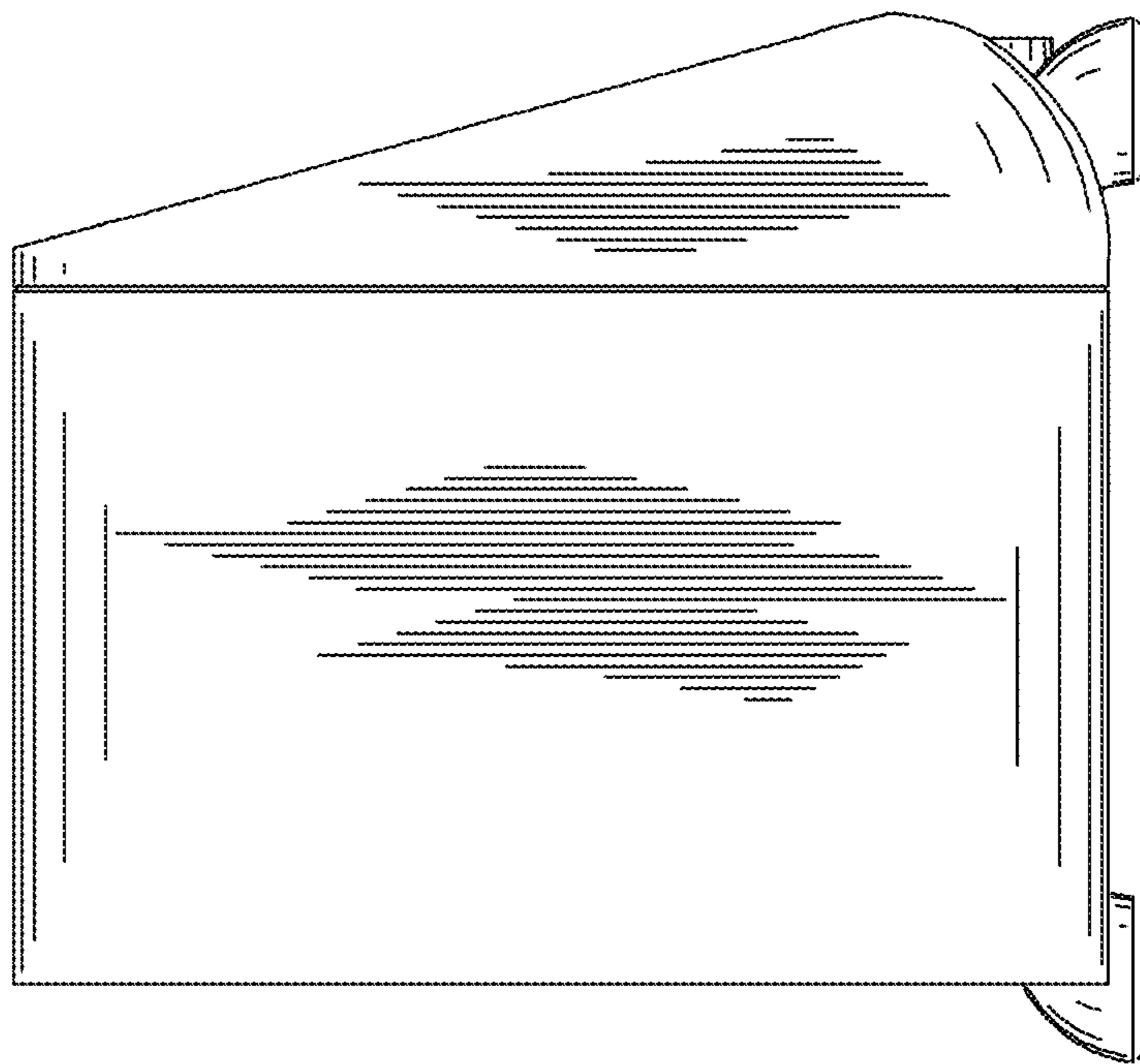

FIG. 9

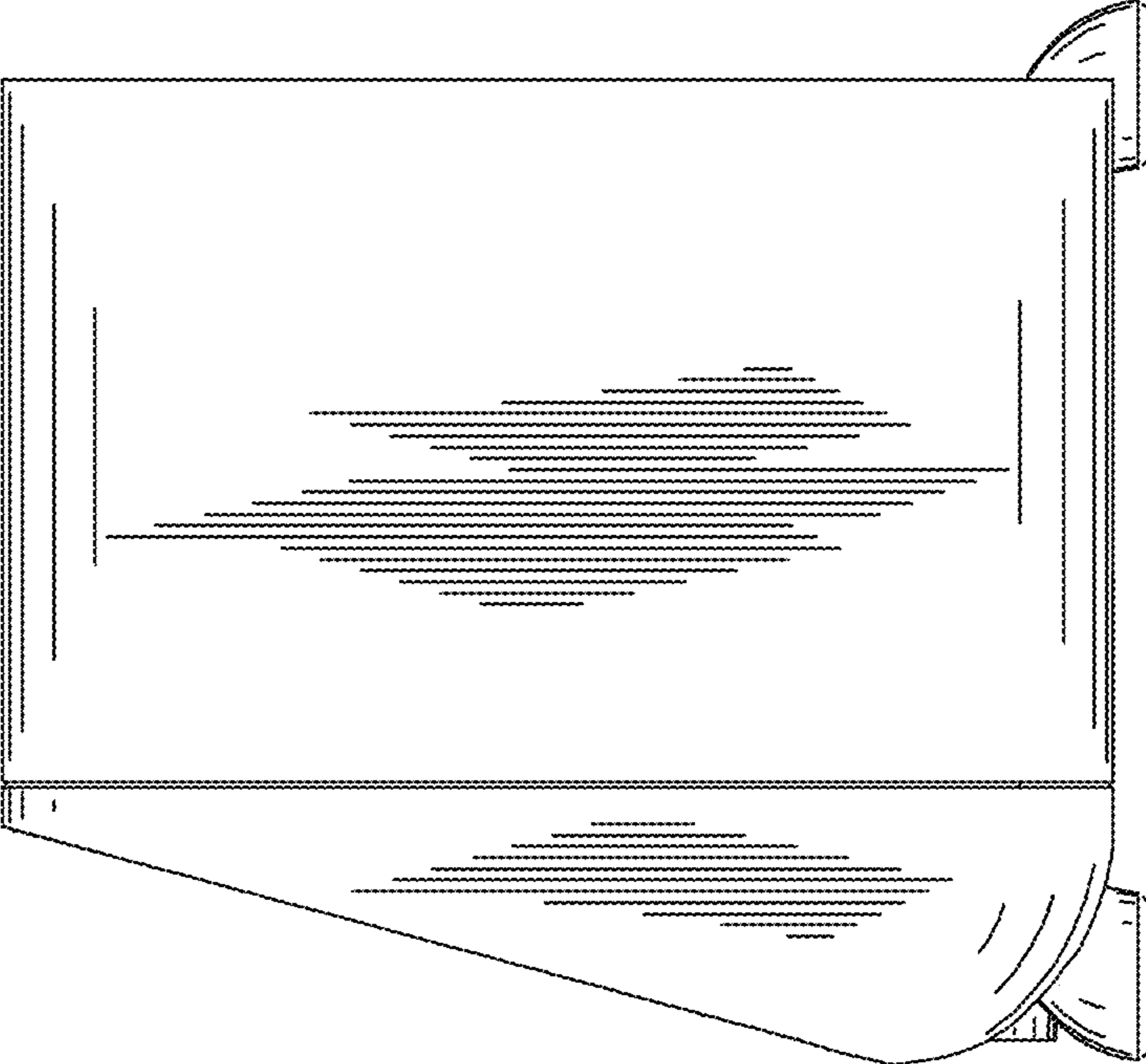

FIG. 10

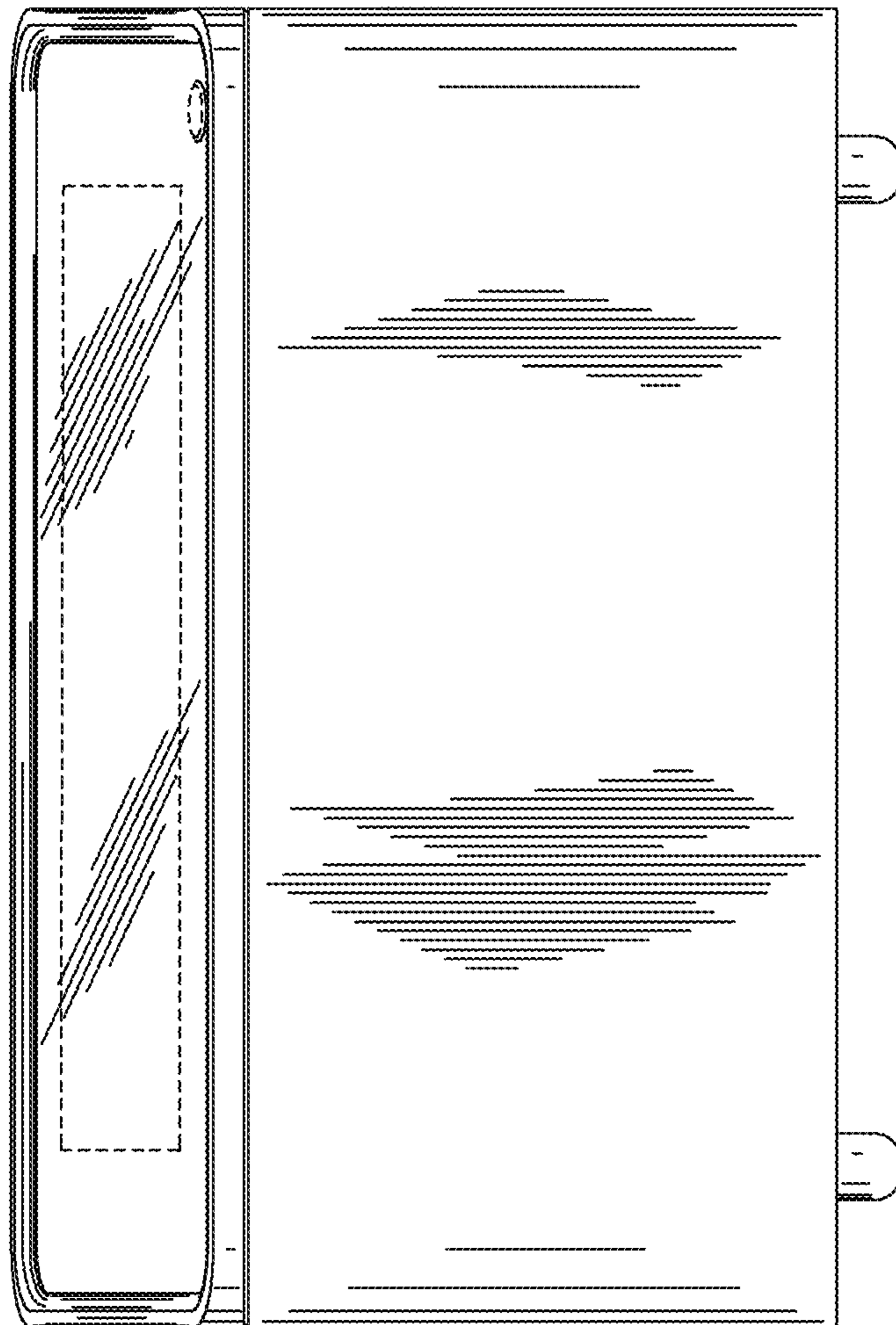

FIG. 11

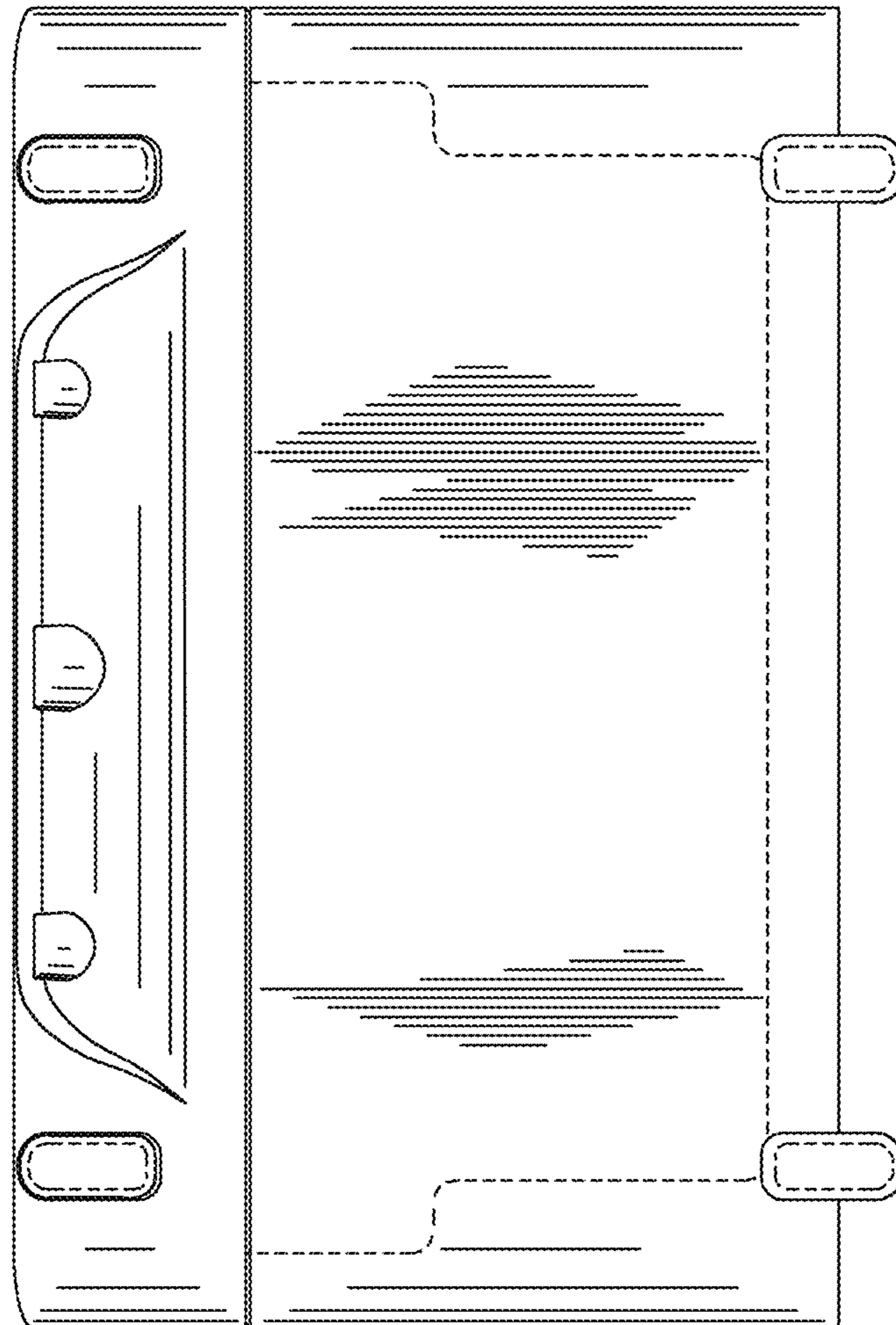

FIG. 12

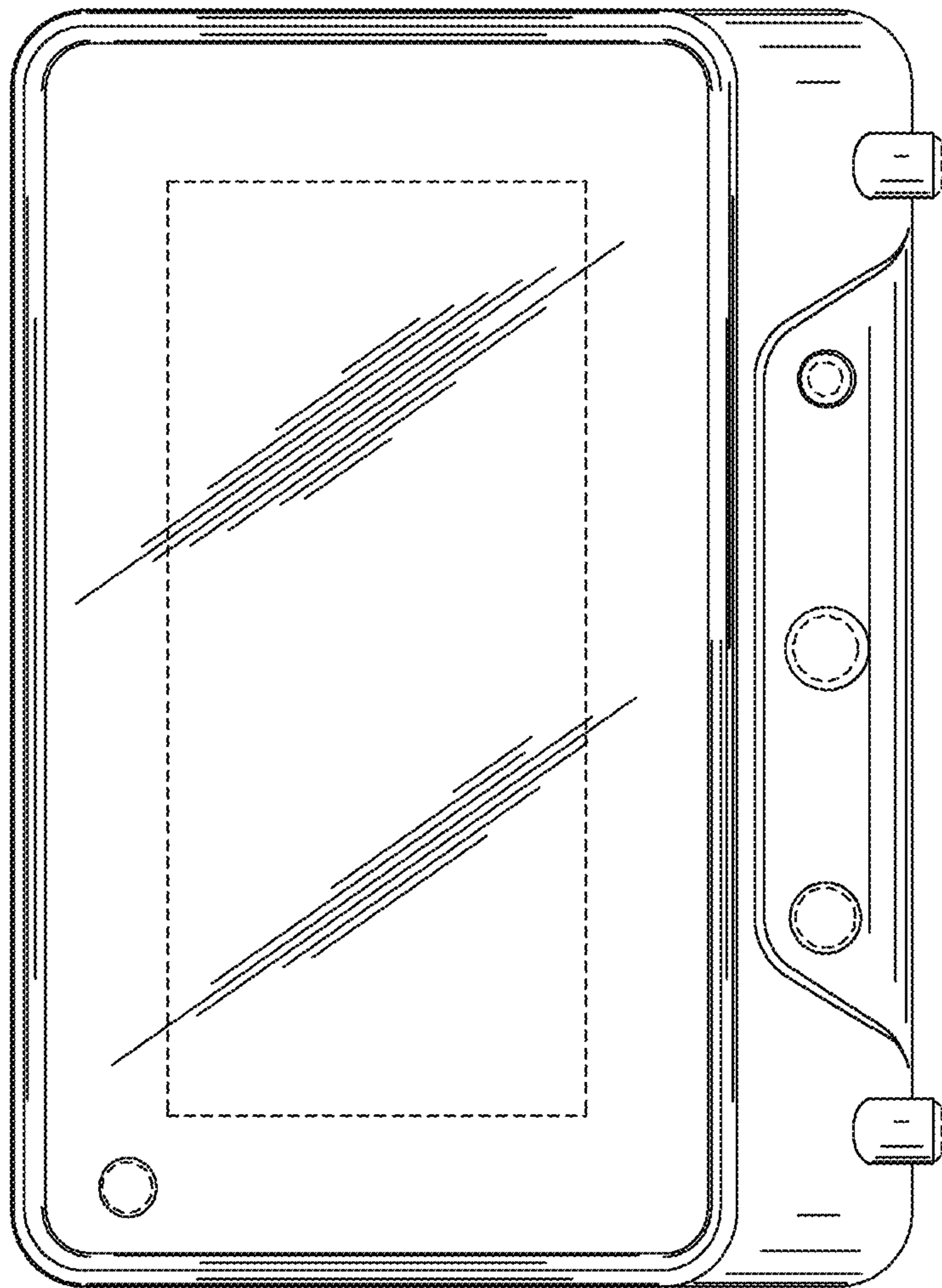

FIG. 13

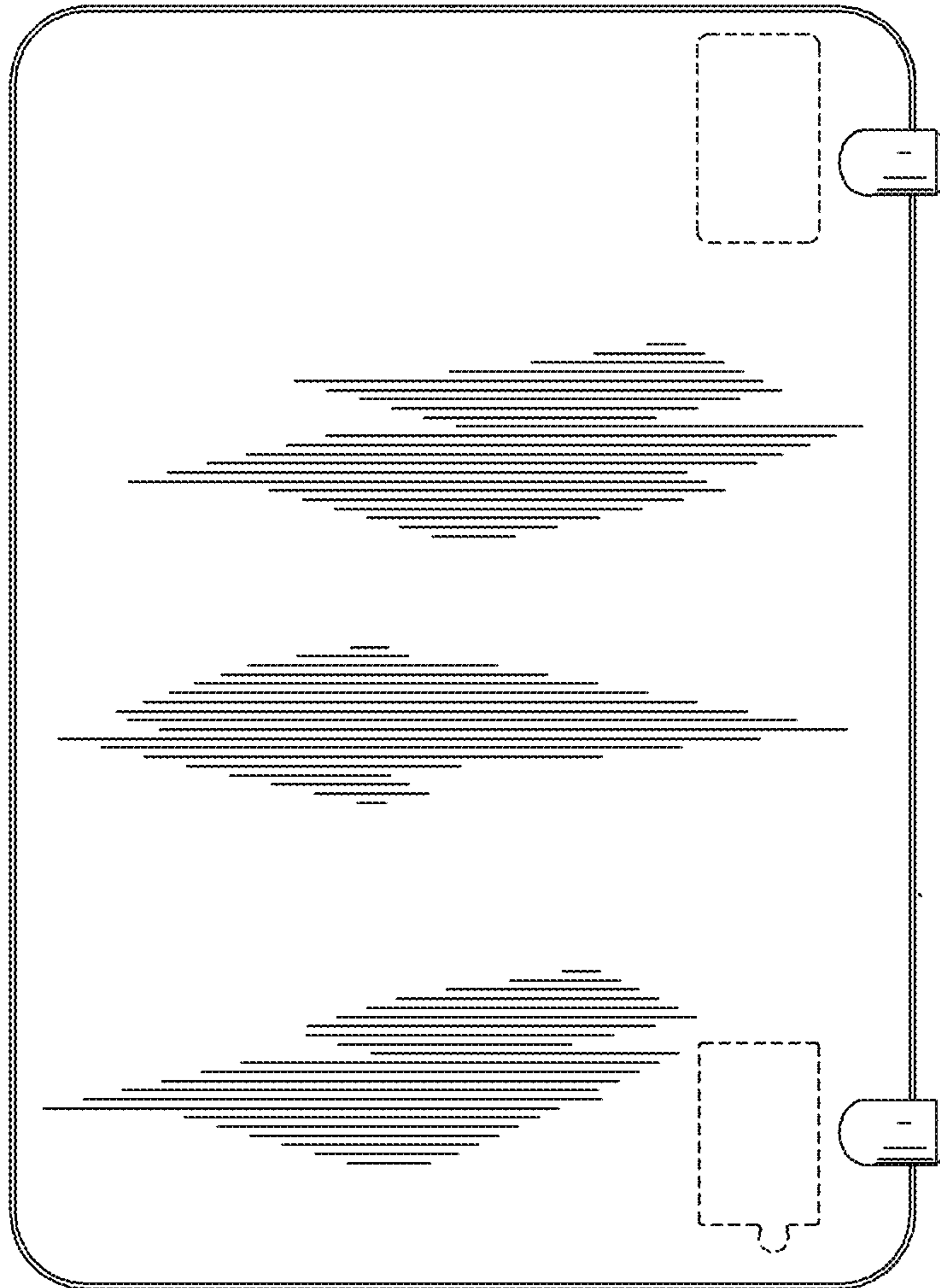

FIG. 14