



US00D834480S

(12) **United States Design Patent** (10) **Patent No.:** **US D834,480 S**
Manzoni (45) **Date of Patent:** **** Nov. 27, 2018**

(54) **INNER HANDLE FOR A DOOR OF A CAR**

(71) Applicant: **Ferrari S.p.A.**, Modena (IT)

(72) Inventor: **Flavio Manzoni**, Maranello (IT)

(73) Assignee: **Ferrari S.p.A.**, Modena (IT)

(**) Term: **15 Years**

(21) Appl. No.: **29/603,625**

(22) Filed: **May 11, 2017**

(30) **Foreign Application Priority Data**

Nov. 14, 2016 (EM) 003462902

(51) **LOC (11) Cl.** **12-08**

(52) **U.S. Cl.**
USPC **D12/195**

(58) **Field of Classification Search**
USPC D12/195, 193, 184, 190, 400, 406, 412,
D12/414, 169, 167; D15/28
CPC ... B60R 13/02; B60R 13/0243; B60N 2/4693;
B60N 3/026; B60J 5/04
See application file for complete search history.

(56) **References Cited**

U.S. PATENT DOCUMENTS

- D433,978 S * 11/2000 Tsay D12/195
- D463,343 S * 9/2002 Siegert D12/195
- D503,913 S * 4/2005 Wyszogrod D12/195
- D519,429 S * 4/2006 Miyashita D12/195
- D531,101 S * 10/2006 Yu D12/195
- D595,200 S * 6/2009 Rosenbohm D12/195
- D616,348 S * 5/2010 Rosenbohm D12/195
- D616,796 S * 6/2010 Rosenbohm D12/195
- D744,544 S * 12/2015 Wuisan D15/28
- D761,176 S * 7/2016 Sandys D12/195

- D766,792 S * 9/2016 Shimizu D12/195
- D800,183 S * 10/2017 Wuisan D15/28
- 2009/0121515 A1* 5/2009 Shiono B60N 3/026
296/146.6

* cited by examiner

Primary Examiner — Karen S Acker

Assistant Examiner — Jerry Shiuan-Hua Hsu

(74) *Attorney, Agent, or Firm* — Cowan, Liebowitz & Latman, P.C

(57) **CLAIM**

The ornamental design for an inner handle for a door of a car, as shown and described.

DESCRIPTION

FIG. 1 is a front perspective view of an inner handle for a door of a car showing the present design;
 FIG. 2 is a front view thereof;
 FIG. 3 is a rear view thereof;
 FIG. 4 is a first lateral view thereof;
 FIG. 5 is a second lateral view thereof;
 FIG. 6 is a top plan view thereof;
 FIG. 7 is a bottom view thereof;
 FIG. 8 is a perspective view thereof in a position of use in a car door;
 FIG. 9 is an enlarged perspective view thereof in the position of use in a car door taken from area 9 of FIG. 8; and,
 FIG. 10 is a front view thereof used in a car door as shown in FIG. 9.

Broken lines showing portions of the inner handle, portions of the car and the boundaries of the detail areas depict environment that forms no part of the claimed design. Dash dot broken lines illustrate the boundaries of the claim. The dash dot broken lines and the area within do not form part of the claimed design.

1 Claim, 10 Drawing Sheets

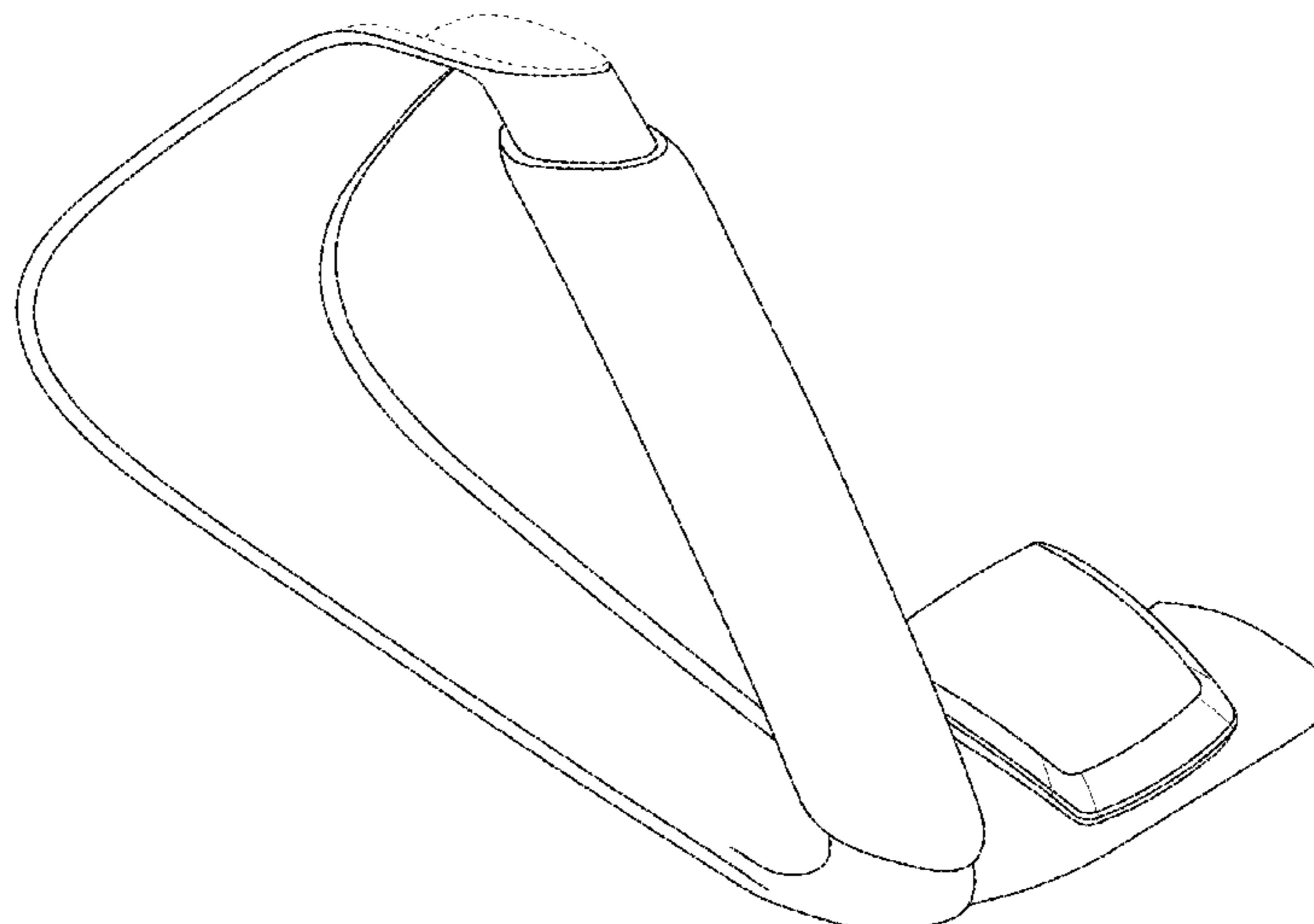

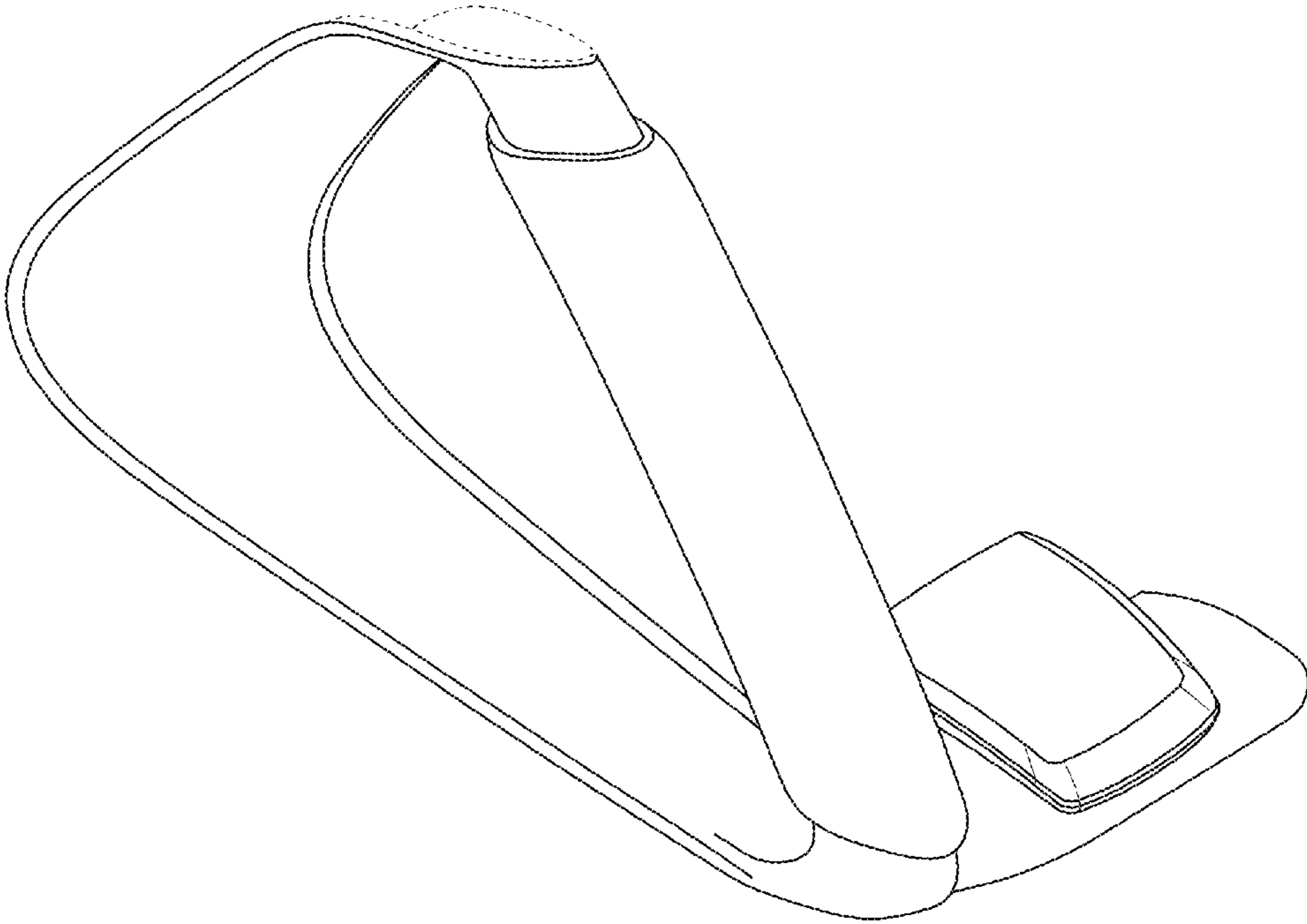

FIG. 1

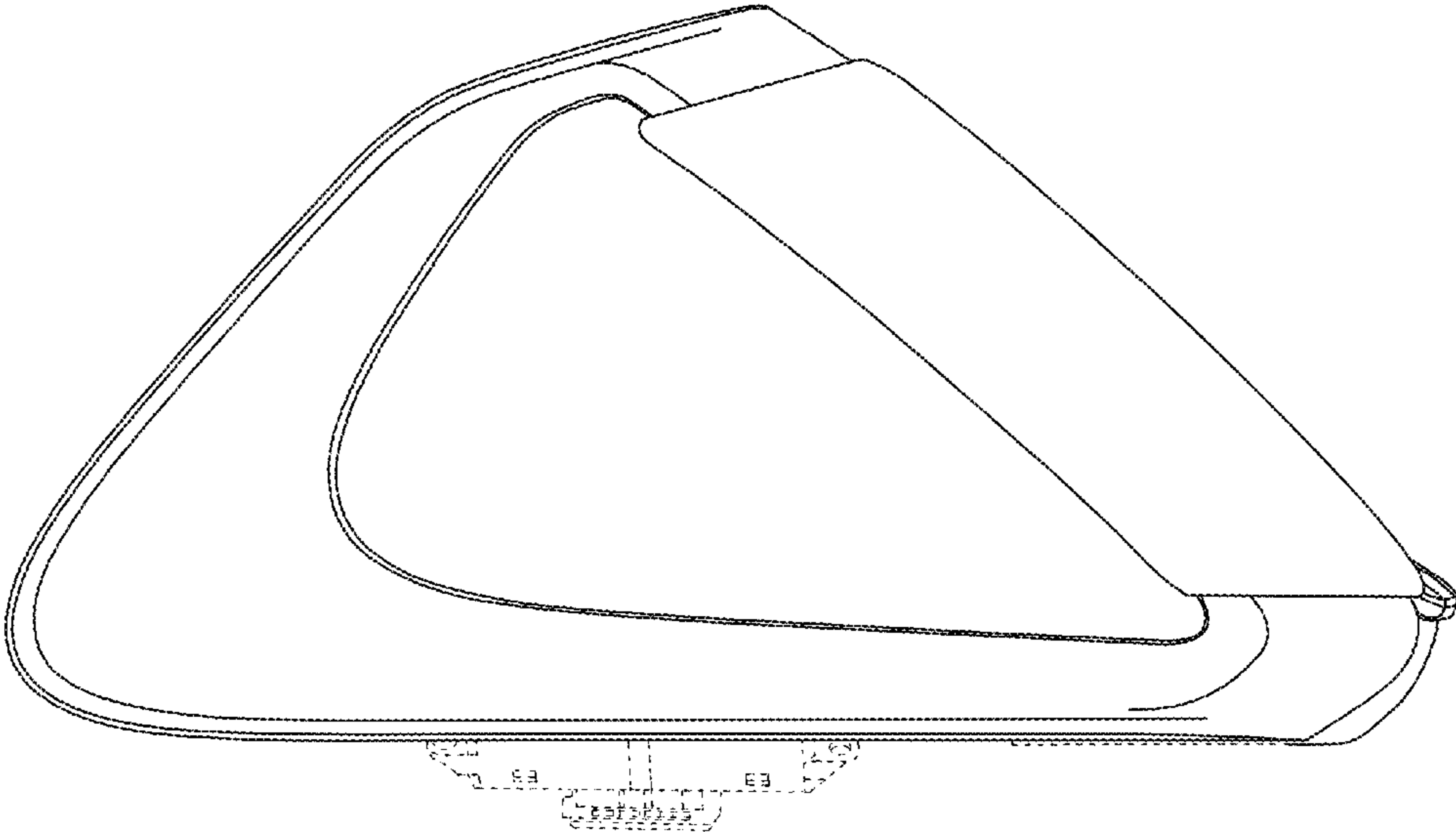

FIG. 2

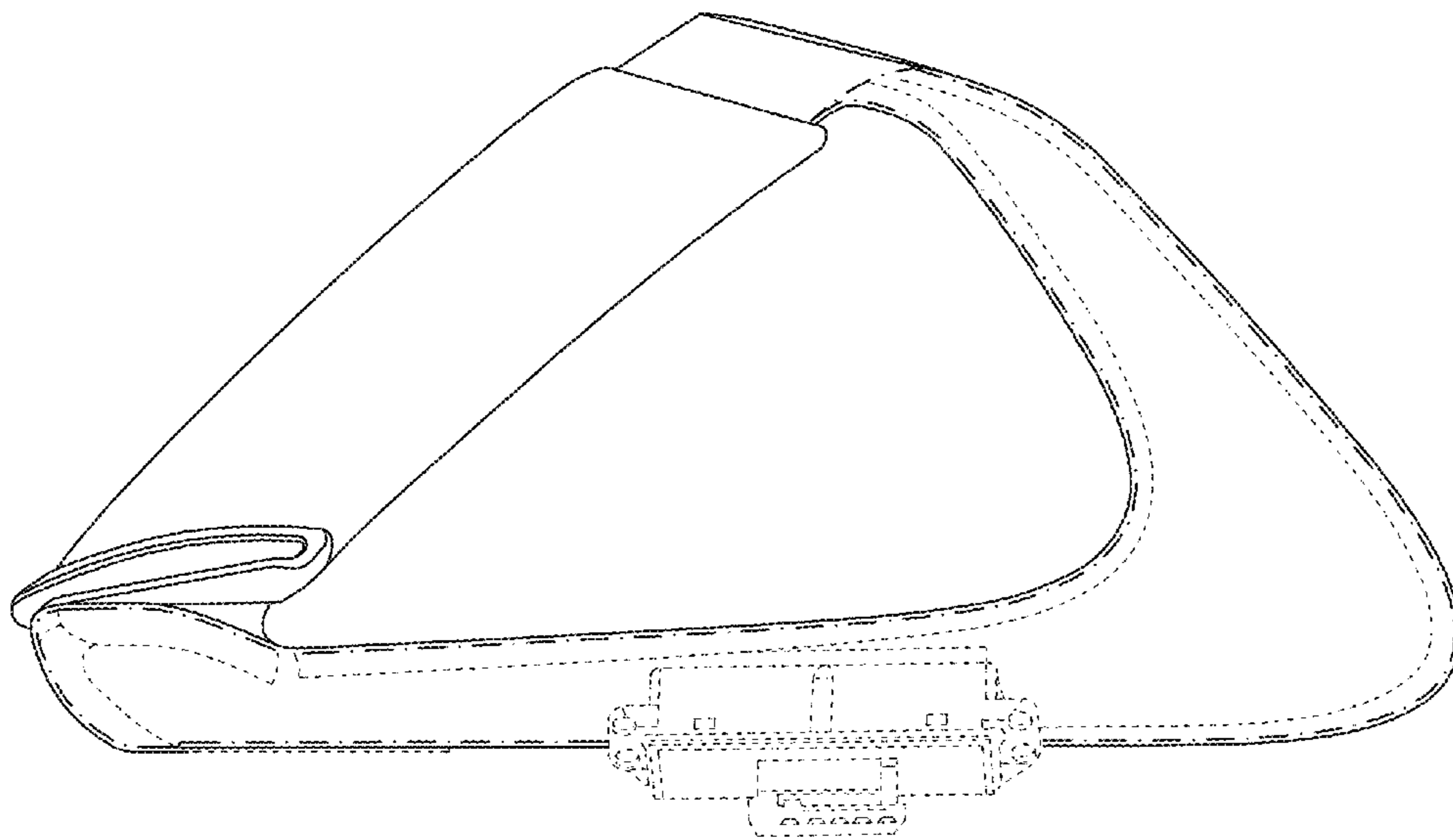

FIG. 3

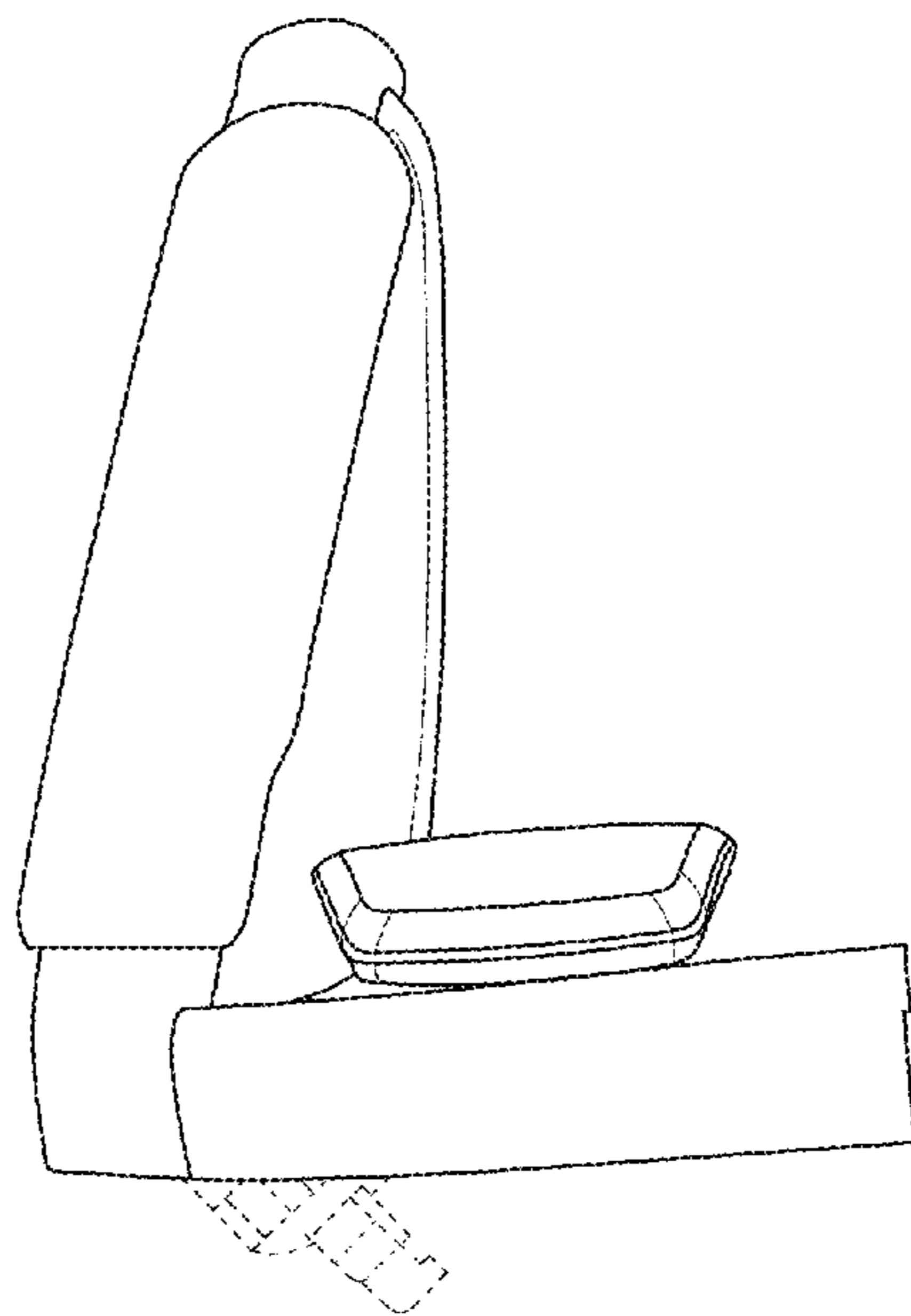

FIG. 4

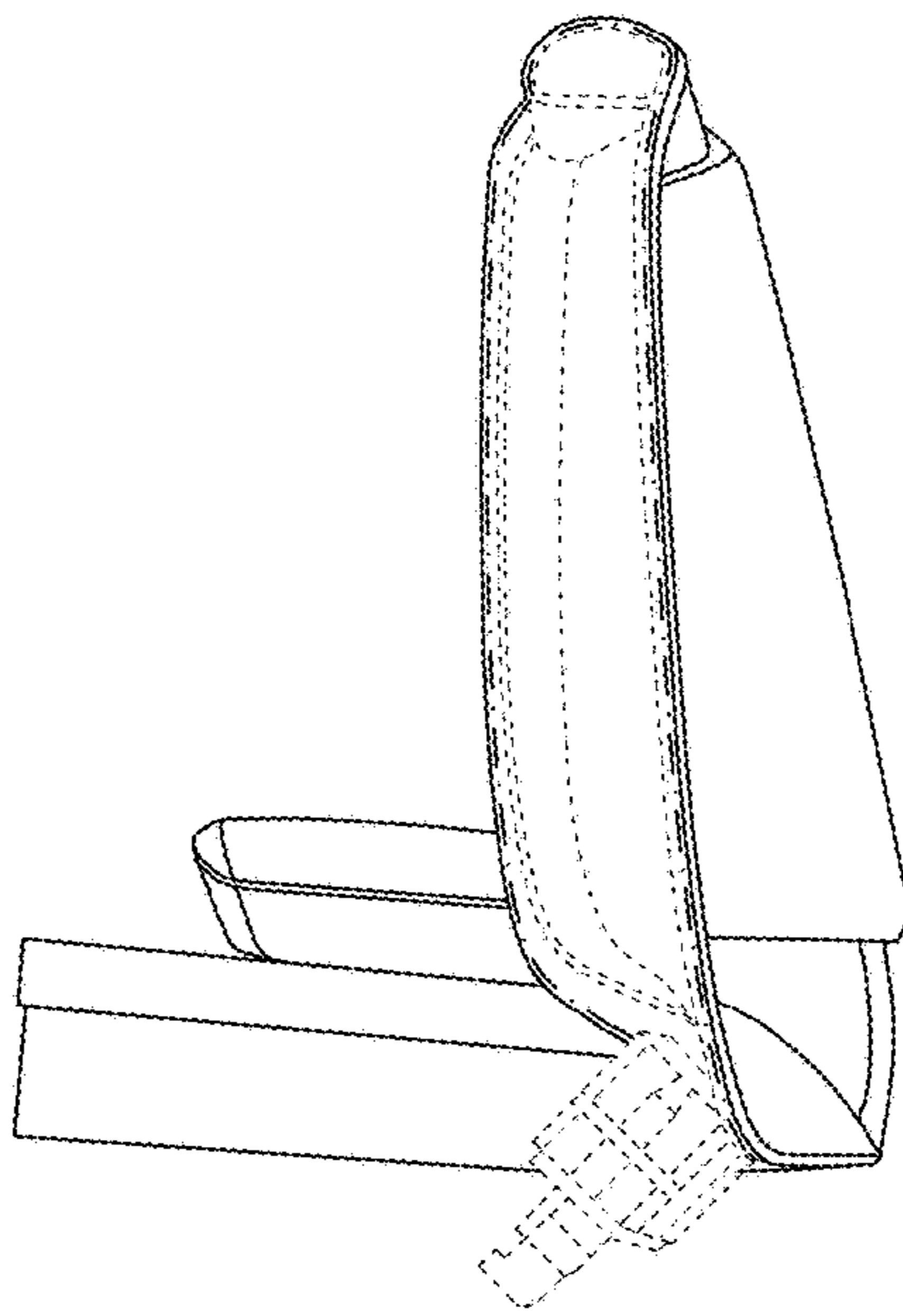

FIG. 5

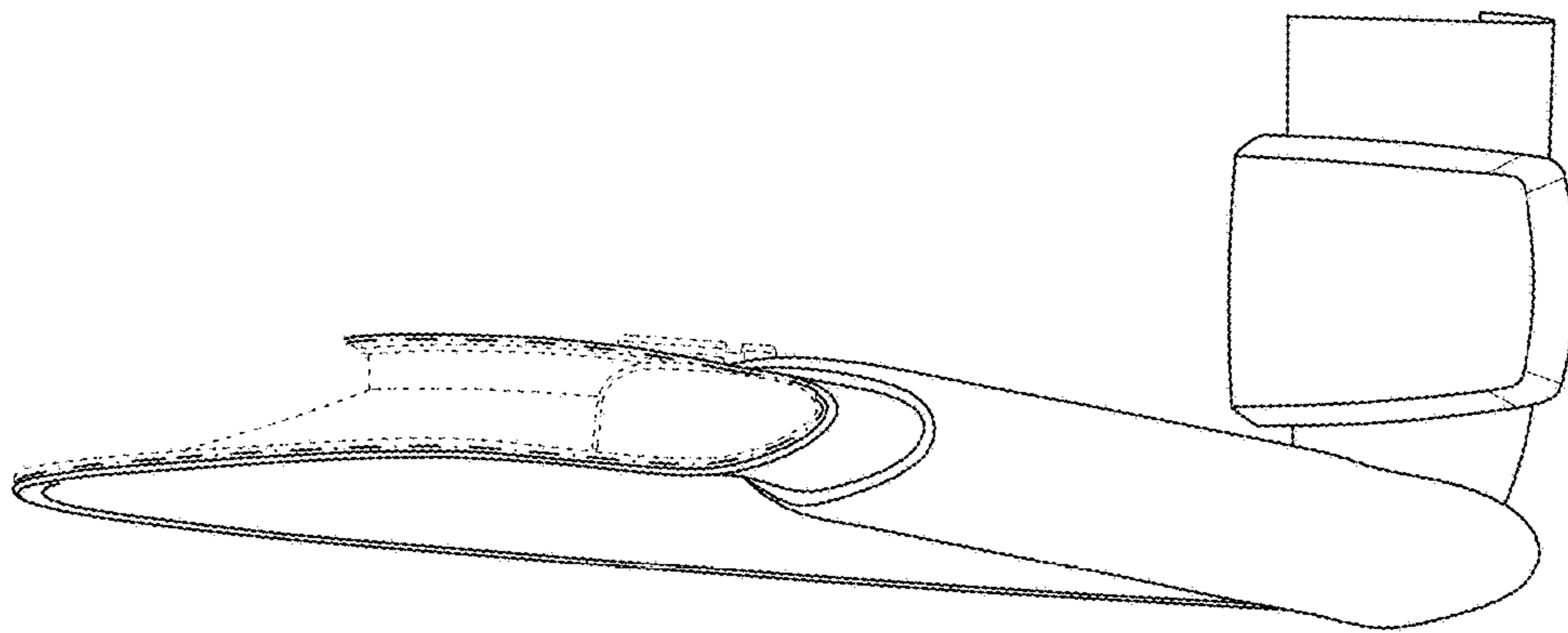

FIG. 6

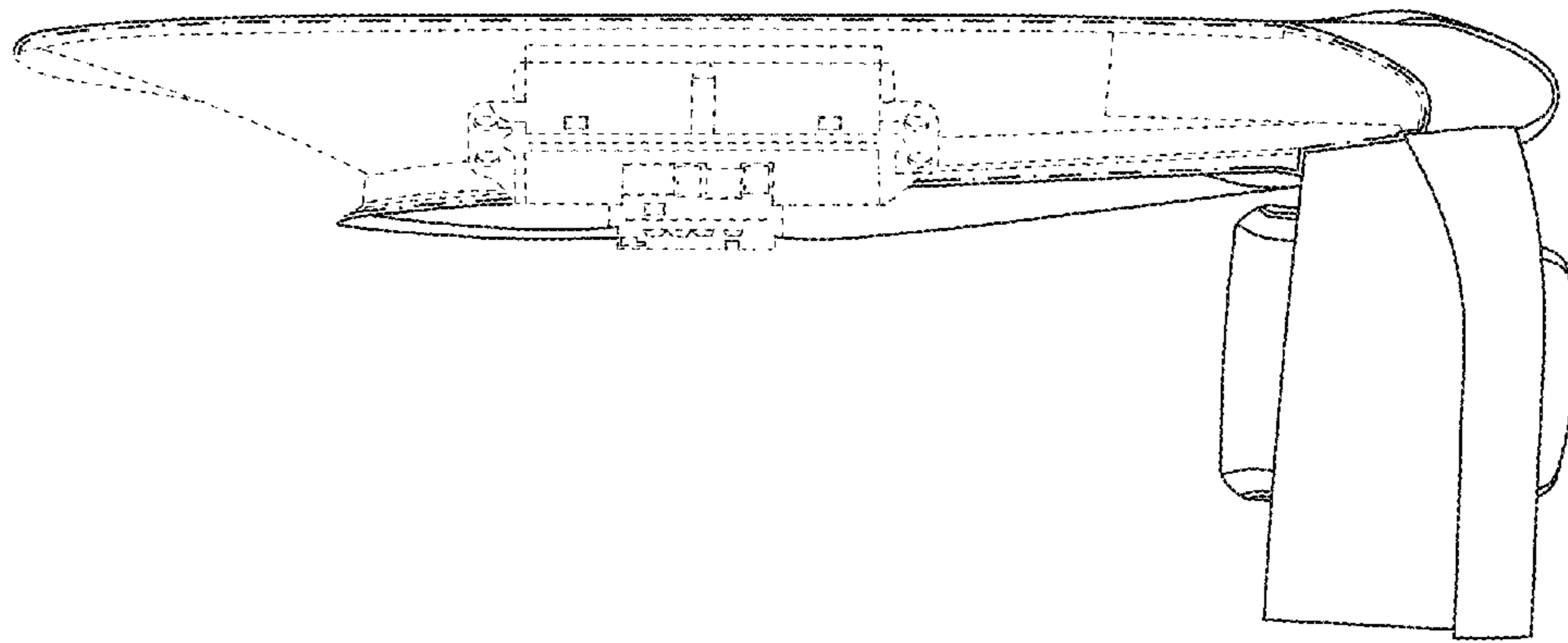
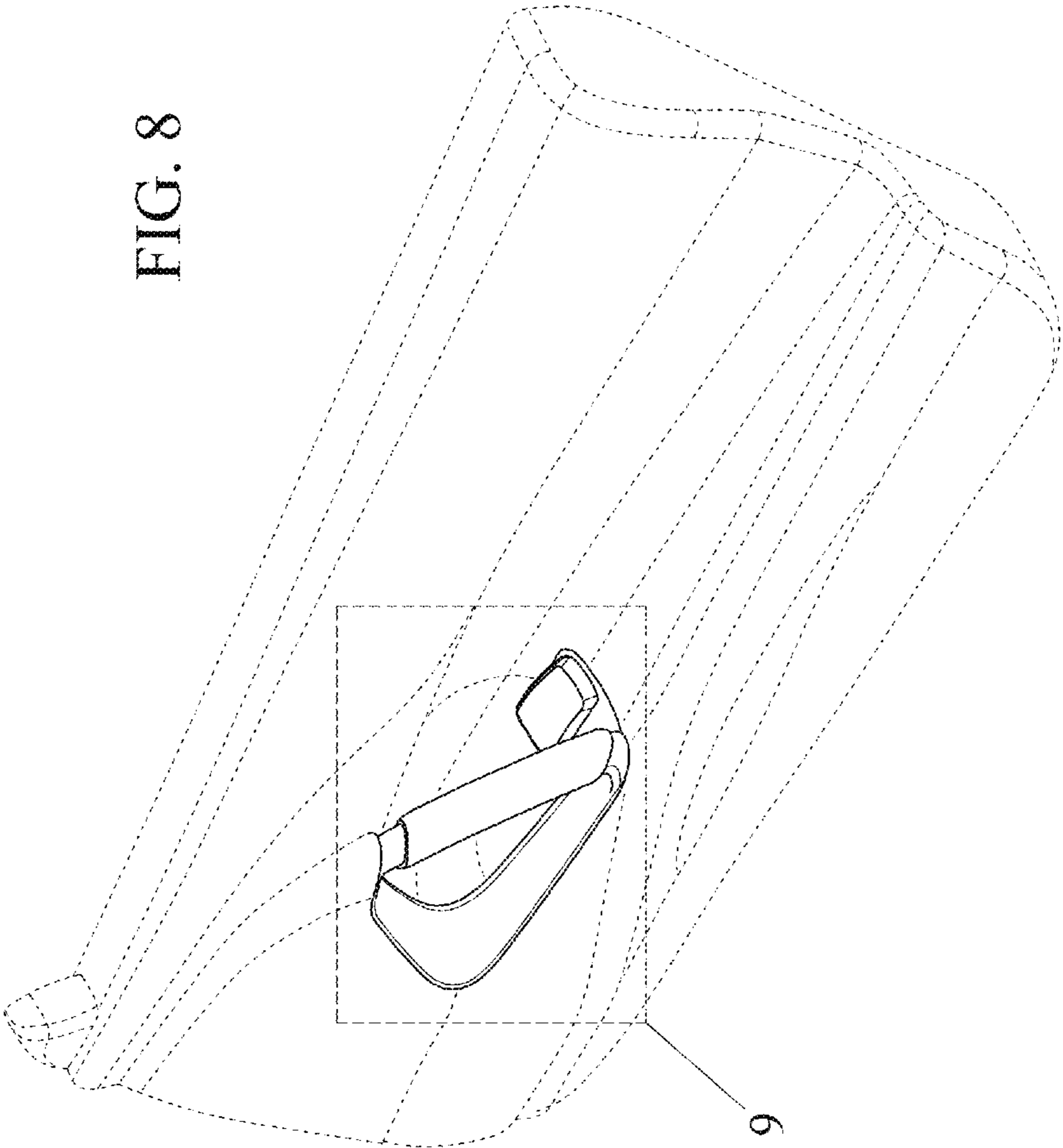

FIG. 7

FIG. 8



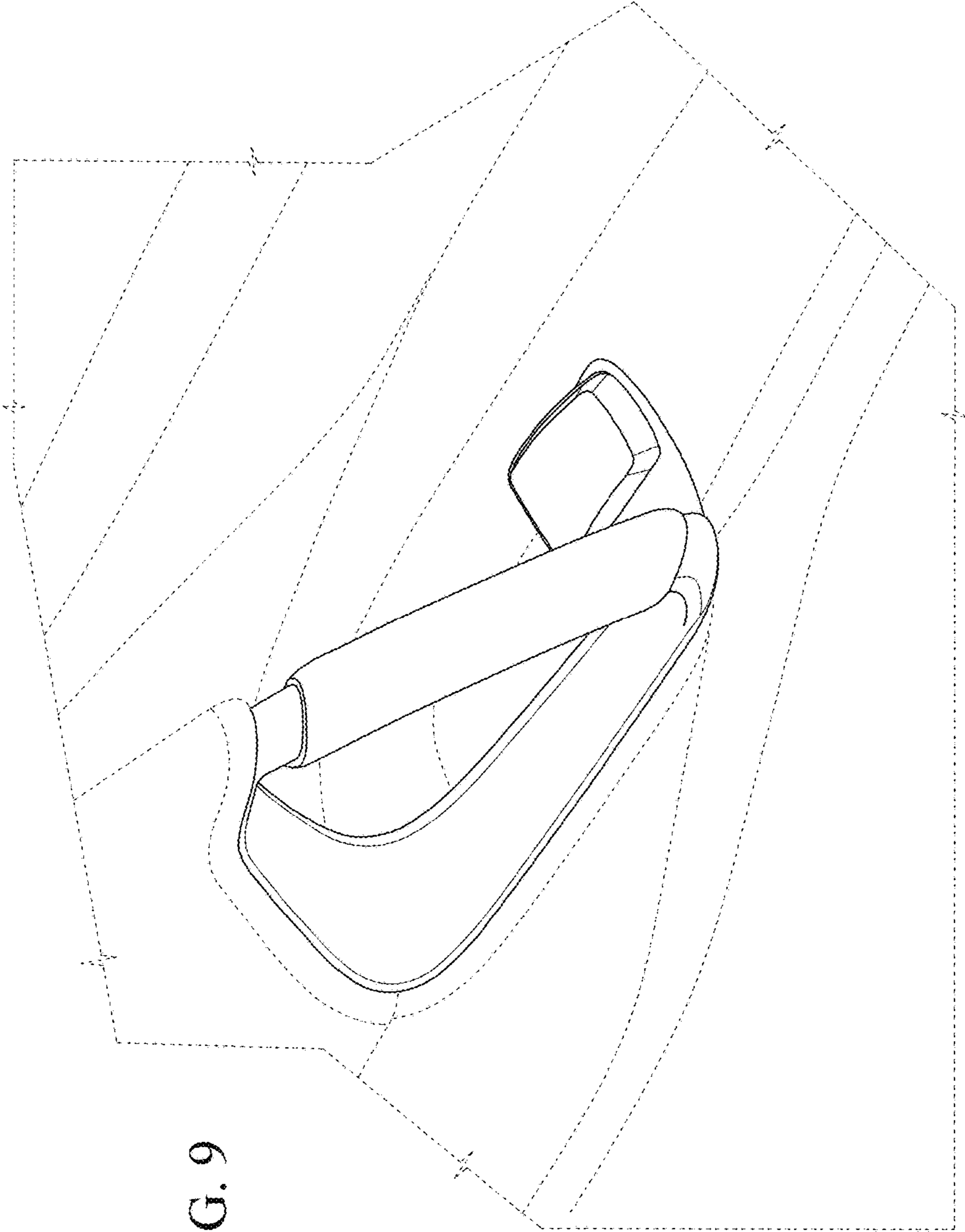

FIG. 9

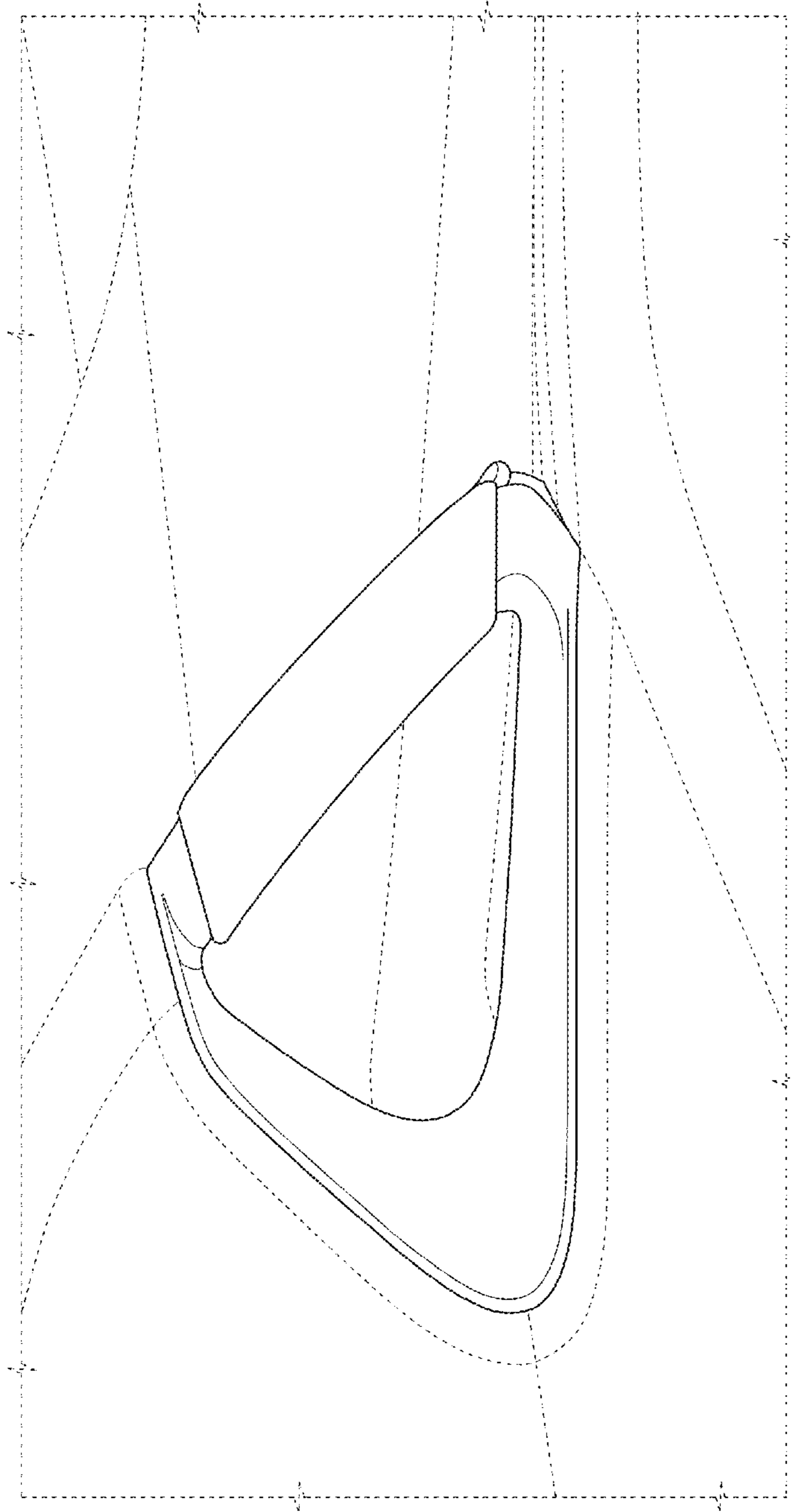

FIG. 10