



US00D834097S

(12) **United States Design Patent** (10) **Patent No.:** **US D834,097 S**  
**Lin et al.** (45) **Date of Patent:** **\*\* Nov. 20, 2018**

(54) **SCOOTER**

(71) Applicant: **MELTON INDUSTRIAL (DONG GUAN) CO., LTD.**, Dong Guan, Guan Dong Province (CN)

(72) Inventors: **Chang-Wei Lin**, Dong Guan (CN); **Ming-Hsien Wu**, Dong Guan (CN)

(73) Assignee: **Dongguan Hong Lin Industrial Co., Ltd.**, Dongguan, Guangdong (CN)

(\*\*) Term: **15 Years**

(21) Appl. No.: **29/587,550**

(22) Filed: **Dec. 14, 2016**

(30) **Foreign Application Priority Data**

Jun. 14, 2016 (CN) ..... 2016 3 0237191

(51) **LOC (11) Cl.** ..... **21-01**

(52) **U.S. Cl.**  
USPC ..... **D21/423**

(58) **Field of Classification Search**  
USPC ..... D21/419, 421, 423, 426-428, 435, D21/668-671, 760, 765, 771; D12/1, 8, D12/108, 111, 112, 113  
CPC . B62K 3/002; B62K 9/00; B62K 9/02; B62K 13/00; B62K 2202/00  
See application file for complete search history.

(56) **References Cited**

U.S. PATENT DOCUMENTS

D435,873 S \* 1/2001 Lee ..... D21/423  
D438,912 S \* 3/2001 Barrera ..... D21/423  
D439,623 S \* 3/2001 Barrera ..... D21/423  
D446,259 S \* 8/2001 Udwin ..... D21/423  
D447,187 S \* 8/2001 Powers ..... D21/423

D452,284 S \* 12/2001 McGinnis ..... D21/423  
6,378,880 B1 \* 4/2002 Lin ..... B62K 3/002  
280/87.05  
D654,963 S \* 2/2012 Powers ..... D21/423  
D671,600 S \* 11/2012 Horne ..... D21/423  
D684,217 S \* 6/2013 Hadley ..... D21/423  
D691,671 S \* 10/2013 Chen ..... D21/423  
D692,963 S \* 11/2013 Radtke ..... D21/423  
8,870,200 B2 \* 10/2014 Chen ..... B62B 3/001  
280/87.01  
D717,881 S \* 11/2014 Radtke ..... D21/423  
8,925,935 B2 \* 1/2015 Powers ..... B62K 3/002  
280/655.1  
2002/0093161 A1 \* 7/2002 Udwin ..... B62K 3/002  
280/87.05  
2013/0320648 A1 \* 12/2013 Eckert ..... B62K 3/002  
280/279

\* cited by examiner

*Primary Examiner* — Cynthia M. Chin  
(74) *Attorney, Agent, or Firm* — Muncy, Geissler, Olds & Lowe, P.C.

(57) **CLAIM**

The ornamental design for a scooter, as shown and described.

**DESCRIPTION**

FIG. 1 is a perspective view of a scooter showing my new design;  
FIG. 2 is a front elevational view thereof;  
FIG. 3 is a rear elevational view thereof;  
FIG. 4 is a left side elevational view thereof;  
FIG. 5 is a right side elevational view thereof;  
FIG. 6 is a top plan view thereof; and,  
FIG. 7 is a bottom plan view thereof.  
The broken lines are for the purpose of illustrating portions of the article that form no part of the claim.

**1 Claim, 6 Drawing Sheets**

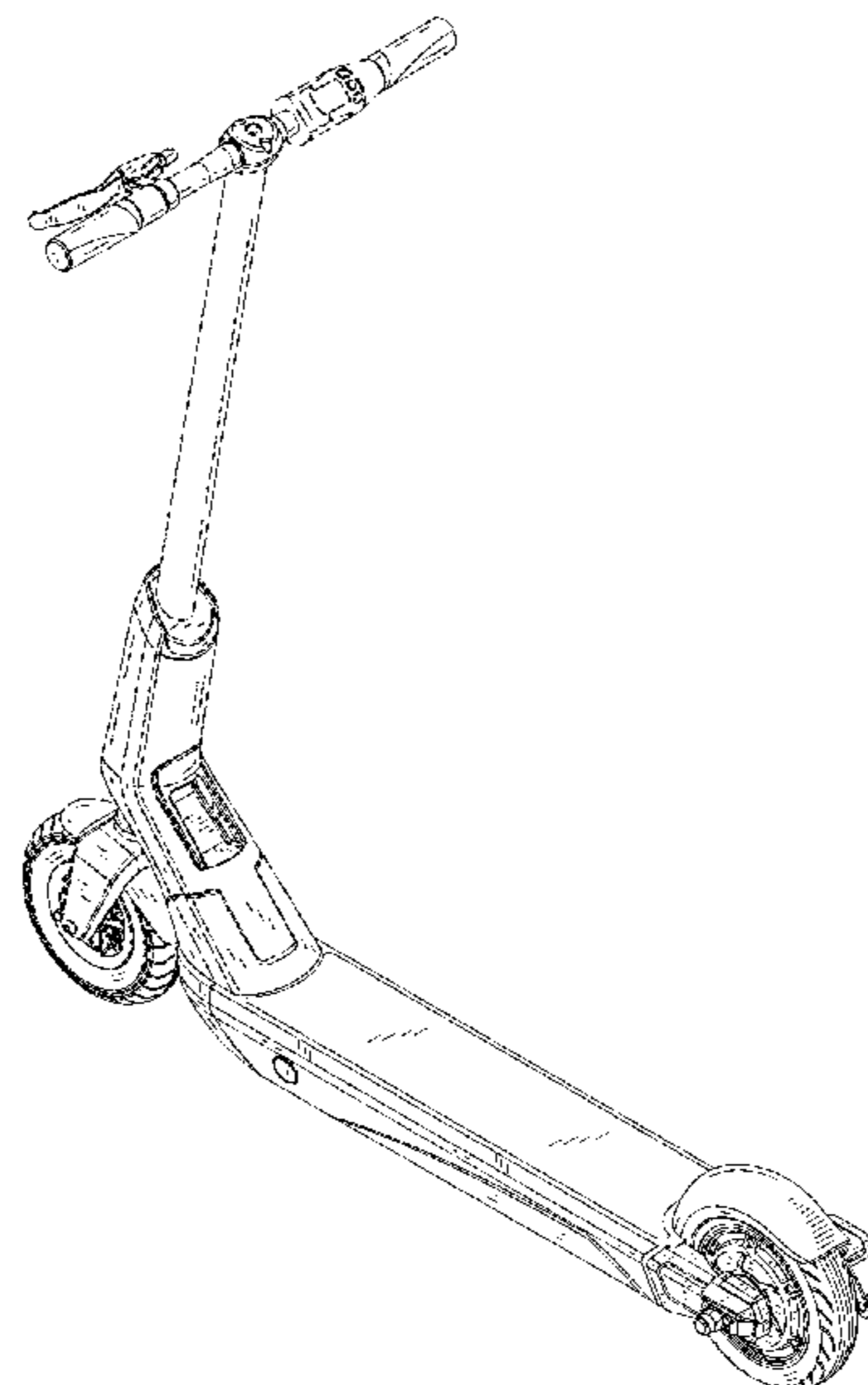

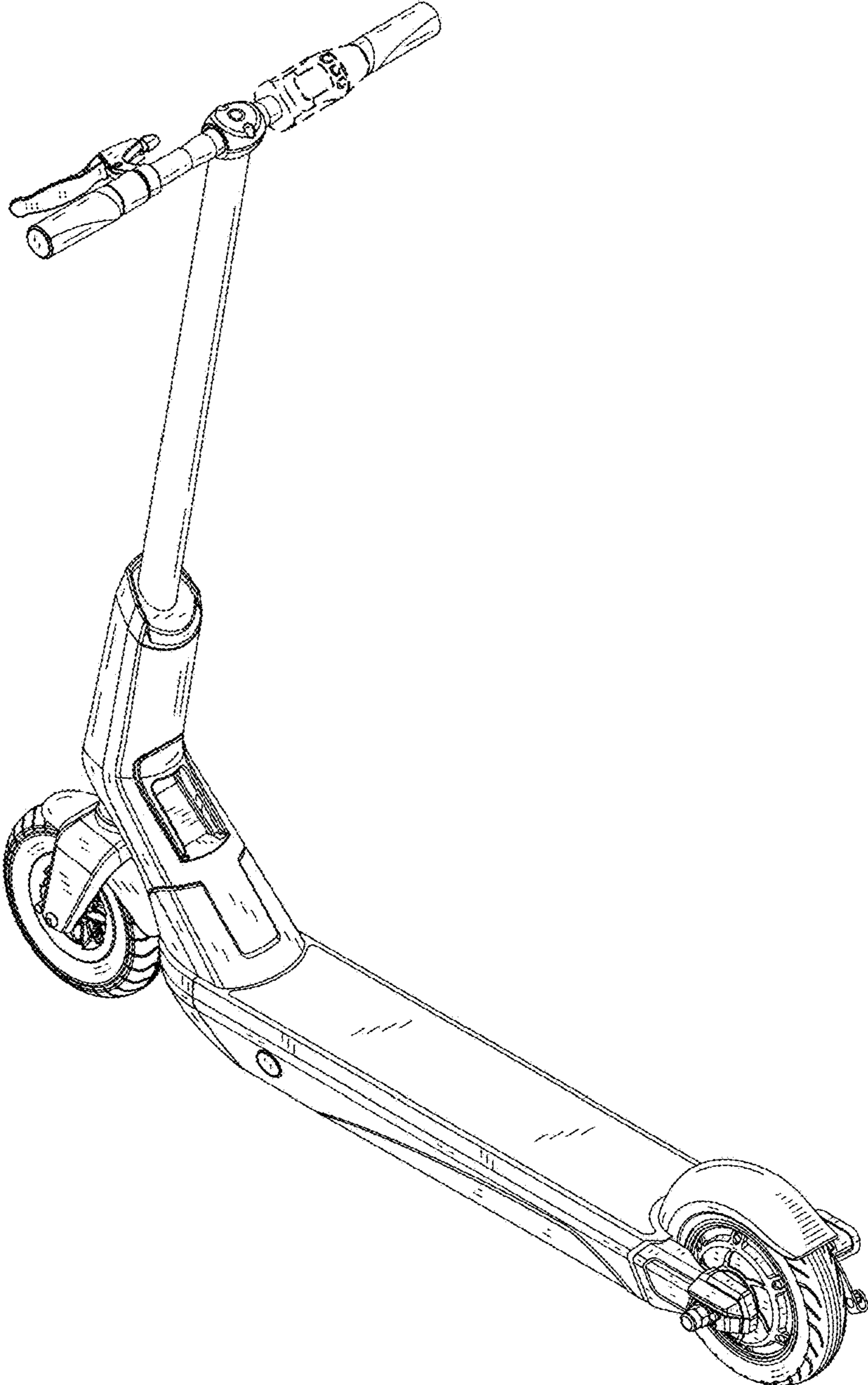

FIG. 1



FIG. 2



FIG. 3

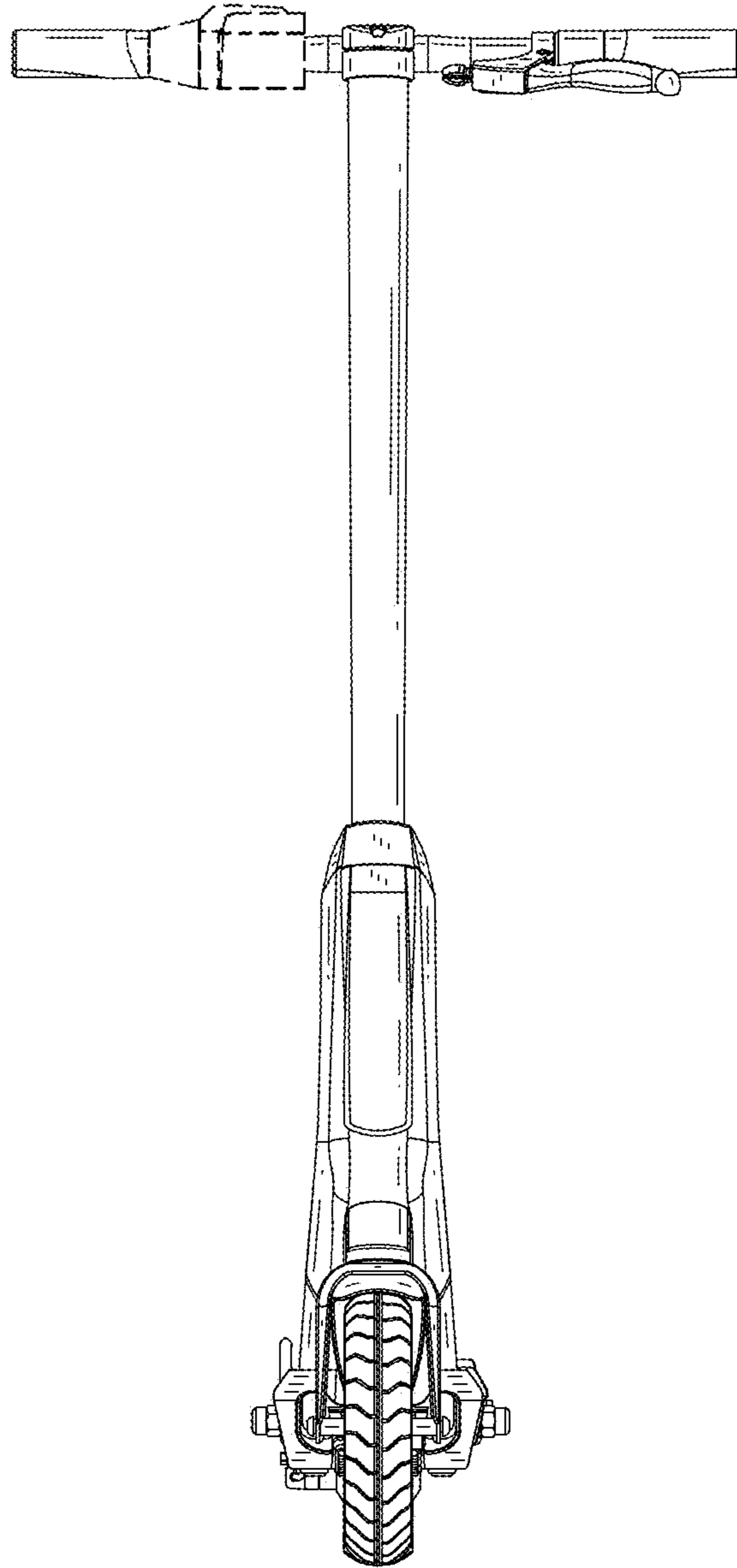

FIG. 4

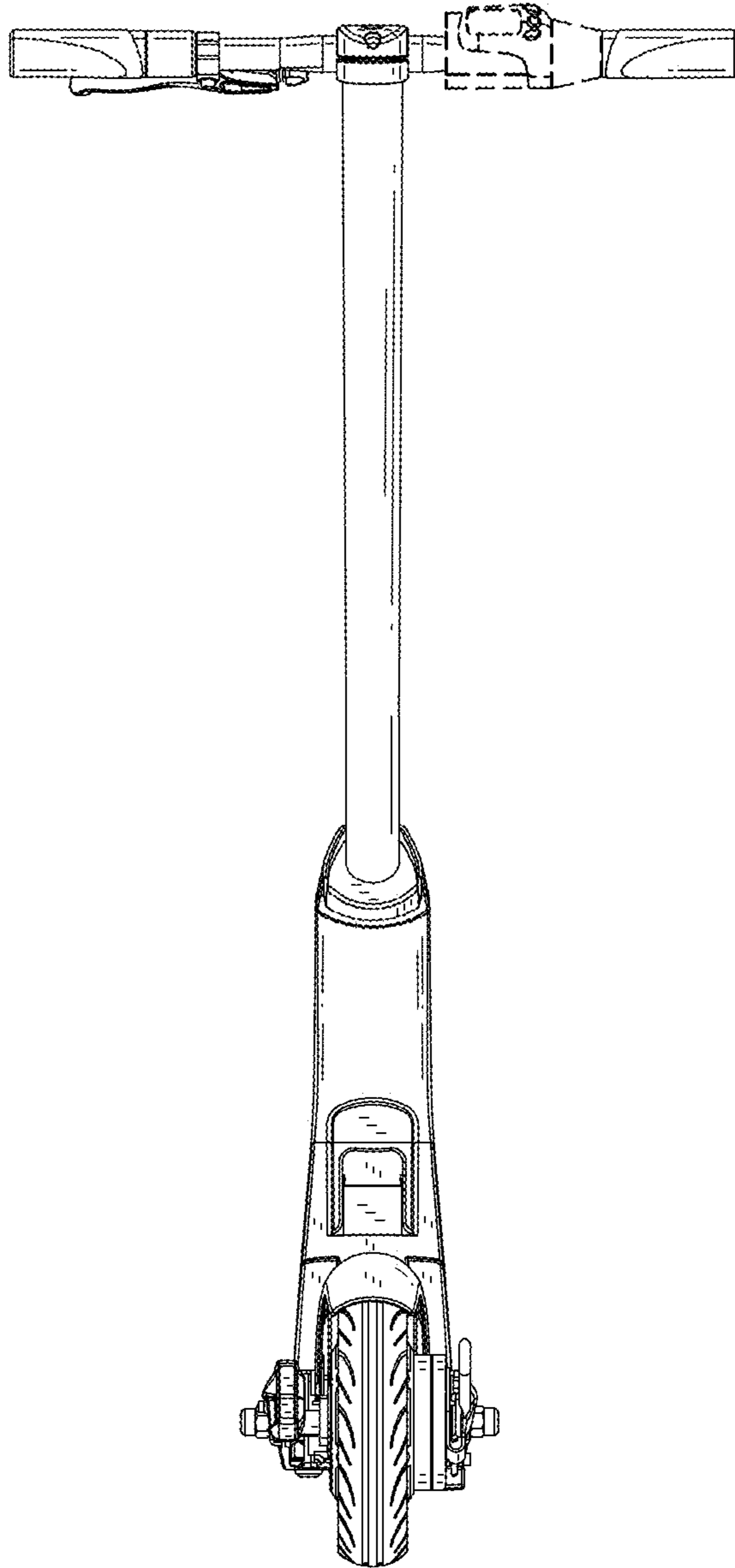

FIG. 5

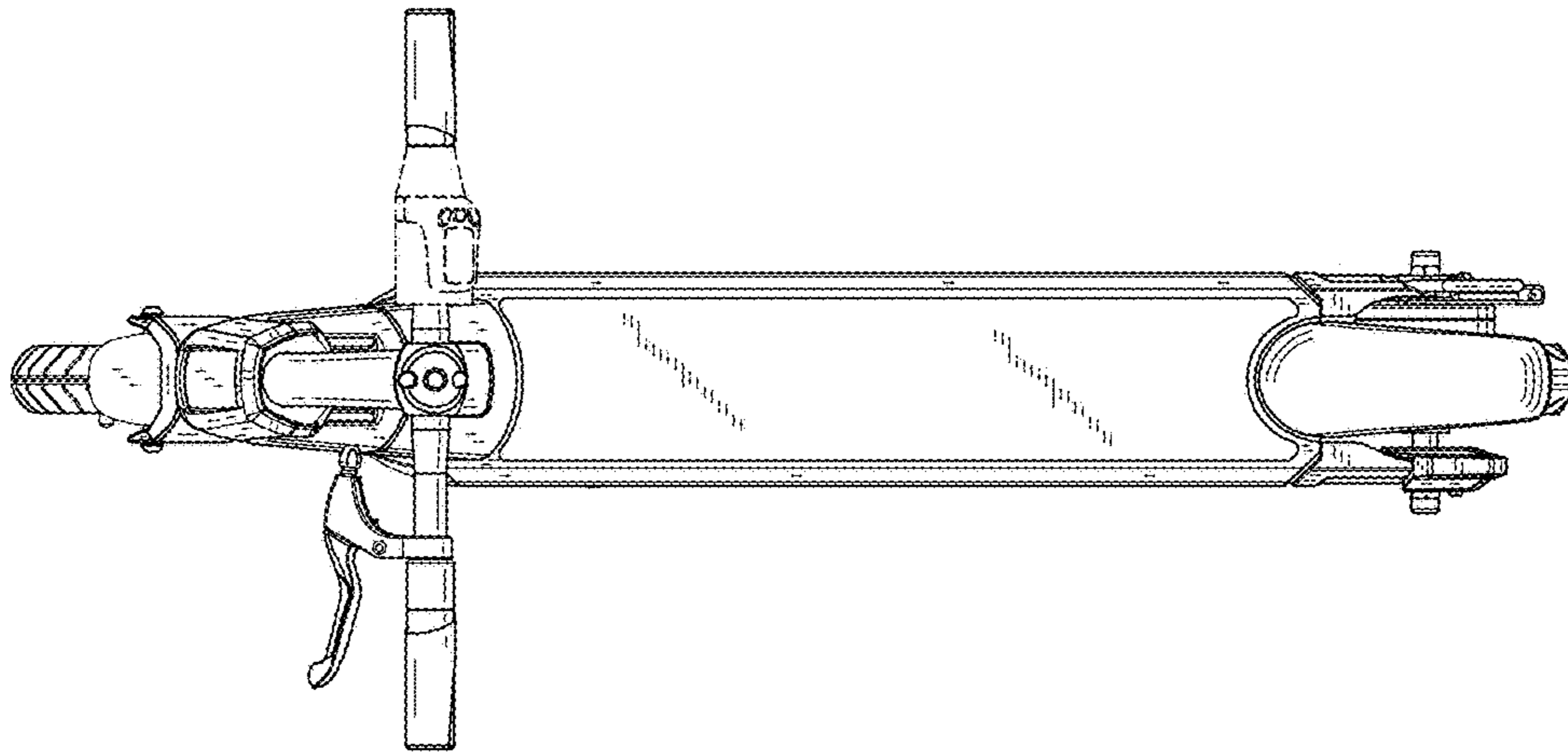

FIG. 6

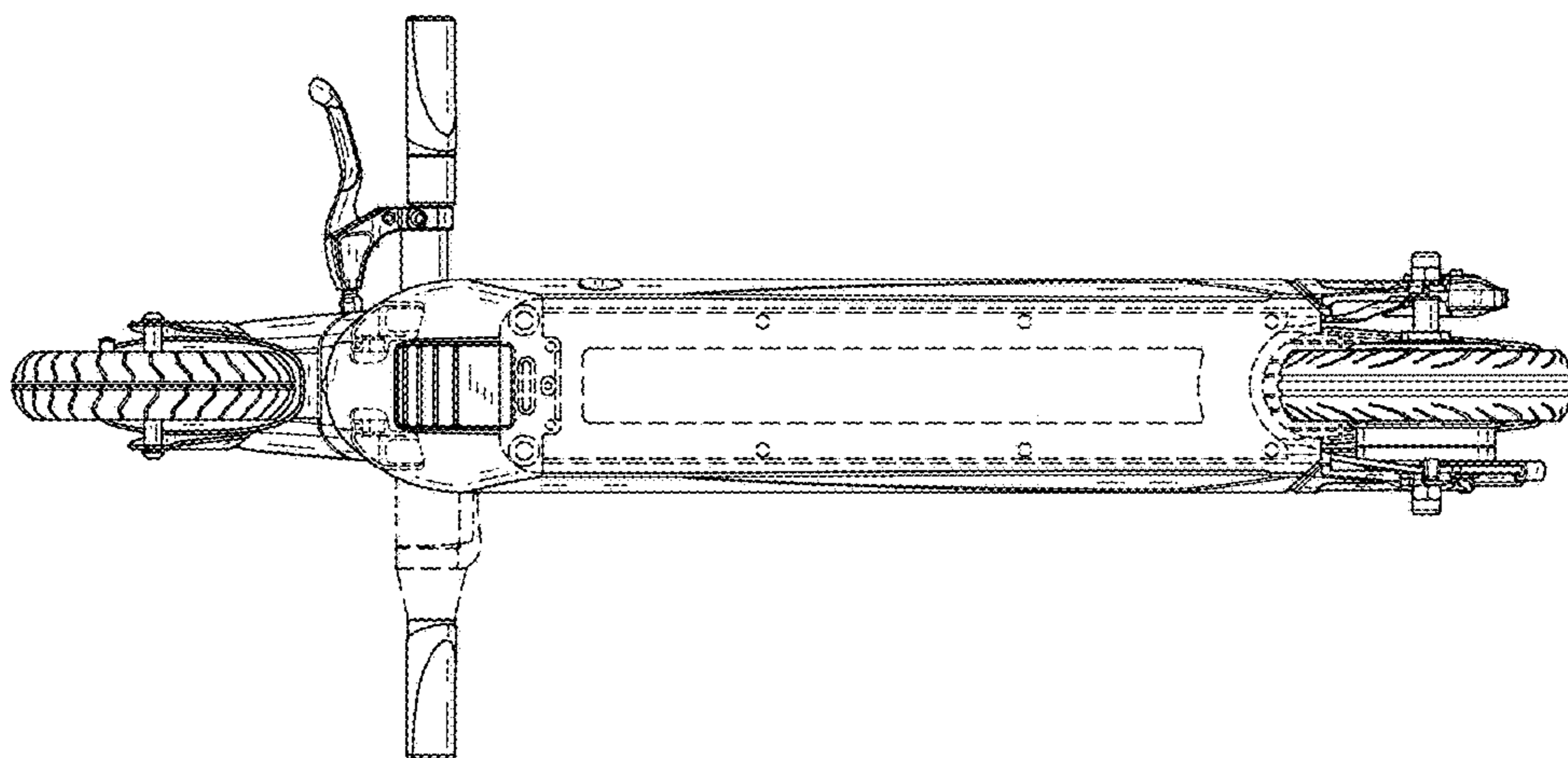

FIG. 7