



US00D833977S

(12) **United States Design Patent**
Danesh et al.

(10) **Patent No.:** **US D833,977 S**

(45) **Date of Patent:** **** Nov. 20, 2018**

(54) **ELECTRICAL JUNCTION BOX**

(71) Applicant: **DMF, Inc.**, Carson, CA (US)

(72) Inventors: **Michael D. Danesh**, Carson, CA (US);
Xinzhi Peng, Downey, CA (US)

(73) Assignee: **DMF, INC.**, Carson, CA (US)

(**) Term: **15 Years**

(21) Appl. No.: **29/645,941**

(22) Filed: **Apr. 30, 2018**

Related U.S. Application Data

(63) Continuation of application No. 29/541,565, filed on Oct. 5, 2015.

(51) **LOC (11) Cl.** **13-03**

(52) **U.S. Cl.**
USPC **D13/152**

(58) **Field of Classification Search**
USPC D13/152, 119, 147, 156, 177, 184, 107,
D13/108, 110, 123, 133, 137.1-137.4,
(Continued)

(56) **References Cited**

U.S. PATENT DOCUMENTS

2,038,784 A 4/1936 Ghadiali
2,697,535 A * 12/1954 Olson H02G 3/085
220/3.2

(Continued)

FOREIGN PATENT DOCUMENTS

CA 2815067 11/2013
CN 201259125 Y 6/2009

(Continued)

OTHER PUBLICATIONS

Non-Final Office Action dated May 16, 2018 for U.S. Appl. No. 15/132,875, 18 pages.

(Continued)

Primary Examiner — Rosemary K Tarcza

Assistant Examiner — Christy M Nemeth

(74) *Attorney, Agent, or Firm* — Smith Baluch LLP

(57) **CLAIM**

The ornamental design for an electrical junction box, as shown and described.

DESCRIPTION

FIG. 1 is a top, side perspective of an electrical junction box of our new design, according to a first embodiment; FIG. 2 is a second top, side perspective view thereof; FIG. 3 is a top plan view thereof; FIG. 4 is a front elevation view thereof, the rear elevation view being identical; FIG. 5 is a right-side elevation view thereof, the left-side elevation view being identical; FIG. 6 is a bottom plan view thereof; FIG. 7 is a front, right-side, bottom perspective view thereof; FIG. 8 is a top plan view thereof; FIG. 9 is a front elevation view thereof, the rear elevation view being identical; FIG. 10 is a right-side view thereof, the left-side view being identical; FIG. 11 is a bottom plan view thereof; FIG. 12 is a front, right-side, bottom perspective view thereof; FIG. 13 is a top, side perspective of an electrical junction box of our new design, according to a second embodiment; FIG. 14 is a top plan view thereof; FIG. 15 is a front elevation view thereof, the rear elevation view being identical; FIG. 16 is a right-side elevation view thereof, the left-side elevation view being identical; FIG. 17 is a bottom plan view thereof; and, FIG. 18 is a front, right-side, bottom perspective view thereof.

The broken lines in the drawings are for the purpose of illustrating environmental subject matter and portions of the electrical junction box that form no part of the claimed design.

1 Claim, 11 Drawing Sheets

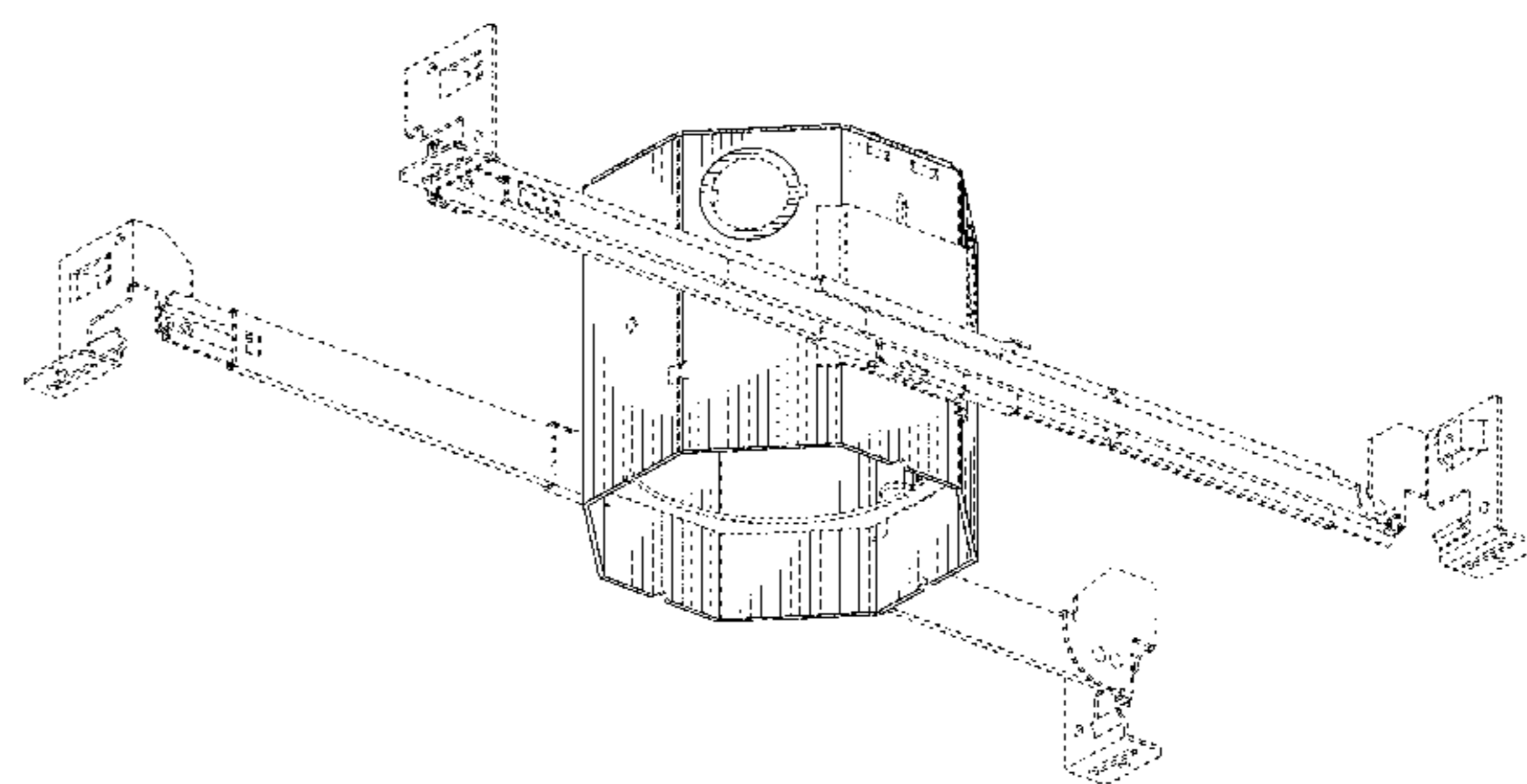
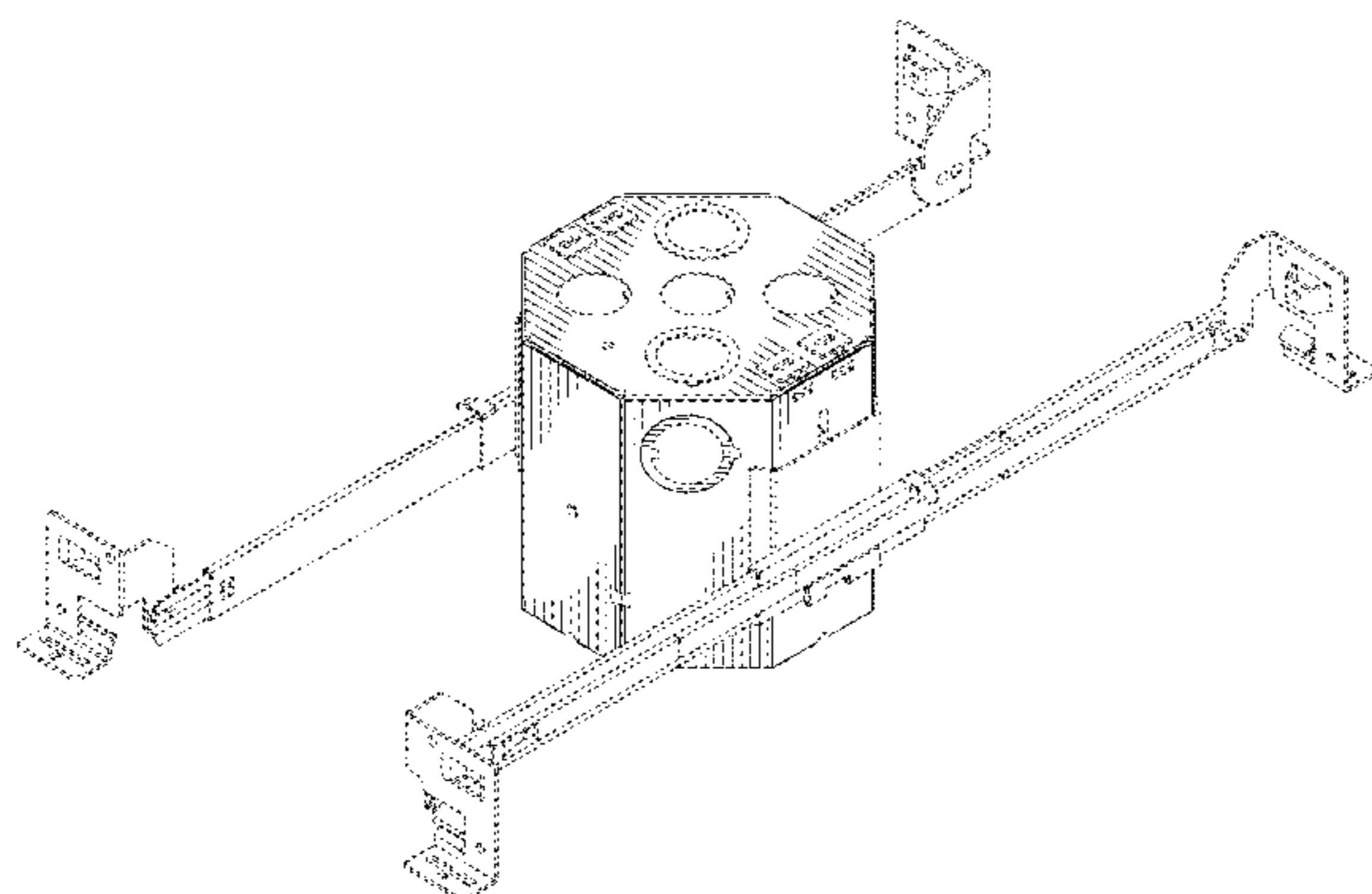

(58) **Field of Classification Search**
 USPC ... D13/138.1–138.2, 139.1–139.8, 153, 154,
 D13/146, 158; D8/350, 351–353;
 D25/119, 127, 134, 48.4; D26/74
 CPC F21S 8/02; F21V 23/00; F21V 23/001;
 H01R 25/00; H01R 25/006; H01R 11/00;
 H01R 9/00; F16J 13/10; F16B 5/02
 See application file for complete search history.

D531,740 S 11/2006 Maxik
 D532,532 S 11/2006 Maxik
 7,186,008 B2 3/2007 Patti
 7,190,126 B1 3/2007 Paton
 D547,889 S 7/2007 Huang
 D553,267 S 10/2007 Yuen
 7,297,870 B1* 11/2007 Sartini H02G 3/125
 174/50

(56) **References Cited**

U.S. PATENT DOCUMENTS

3,422,261 A 1/1969 McGinty
 3,460,299 A 8/1969 Wilson
 3,650,046 A 3/1972 Skinner
 4,088,827 A 5/1978 Kohaut
 4,399,497 A 8/1983 Druffel
 4,520,435 A 5/1985 Baldwin
 4,601,145 A 7/1986 Wilcox
 4,723,747 A 2/1988 Karp et al.
 4,729,080 A 3/1988 Fremont et al.
 4,754,377 A 6/1988 Wenman
 4,757,908 A* 7/1988 Medlin, Sr. H02G 3/126
 220/3.7
 4,770,311 A* 9/1988 Wang H02G 3/123
 220/3.2
 4,929,187 A* 5/1990 Hudson F21V 21/03
 439/334
 4,930,054 A 5/1990 Krebs
 5,216,203 A* 6/1993 Gower H02G 3/088
 174/152 G
 5,250,269 A 10/1993 Langer et al.
 5,382,752 A 1/1995 Reyhan et al.
 5,465,199 A 11/1995 Bray et al.
 5,544,870 A 8/1996 Kelly et al.
 5,562,343 A 10/1996 Chan et al.
 5,571,993 A 11/1996 Jones et al.
 5,580,158 A 12/1996 Aubrey et al.
 5,588,737 A 12/1996 Kusmer
 5,603,424 A 2/1997 Bordwell et al.
 D381,111 S 7/1997 Lecluze
 5,662,413 A 9/1997 Akiyama et al.
 D386,277 S 11/1997 Lecluze
 5,690,423 A* 11/1997 Hentz F21S 8/02
 248/302
 D387,466 S 12/1997 Lecluze
 5,738,436 A 4/1998 Cummings et al.
 5,836,678 A 11/1998 Wright et al.
 5,942,726 A 8/1999 Reiker
 5,944,412 A 9/1999 Janos et al.
 5,975,323 A 11/1999 Turan
 6,082,878 A 7/2000 Doubek et al.
 6,105,334 A 8/2000 Monson et al.
 6,161,910 A 12/2000 Reisenauer et al.
 6,170,685 B1 1/2001 Currier
 6,174,076 B1 1/2001 Petrakis et al.
 6,267,491 B1 7/2001 Parrigin
 6,350,043 B1 2/2002 Gloisten
 6,364,511 B1 4/2002 Cohen
 D461,455 S 8/2002 Forbes
 6,474,846 B1 11/2002 Kelmelis et al.
 6,491,413 B1 12/2002 Benesohn
 6,583,573 B2 6/2003 Bierman
 6,585,389 B2 7/2003 Bonazzi
 D488,583 S 4/2004 Benghozi
 6,719,438 B2 4/2004 Sevac et al.
 6,758,578 B1 7/2004 Chou
 6,777,615 B1* 8/2004 Gretz F04D 25/088
 174/491
 D509,314 S 9/2005 Rashidi
 6,948,829 B2 9/2005 Verdes et al.
 6,964,501 B2 11/2005 Ryan
 D516,235 S 2/2006 Rashidi
 7,064,269 B2* 6/2006 Smith H01R 33/46
 174/481
 D528,673 S 9/2006 Maxik et al.

7,320,536 B2 1/2008 Petrakis et al.
 D561,372 S 2/2008 Yan
 D561,373 S 2/2008 Yan
 D570,012 S 5/2008 Huang
 7,374,308 B2 5/2008 Sevac et al.
 D570,504 S 6/2008 Maxik et al.
 D570,505 S 6/2008 Maxik et al.
 7,399,104 B2 7/2008 Rappaport
 7,429,025 B1* 9/2008 Gretz H02G 3/20
 248/200.1
 D578,677 S 10/2008 Huang
 7,431,482 B1 10/2008 Morgan et al.
 7,473,005 B2 1/2009 O'Brien
 7,488,097 B2 2/2009 Reisenauer et al.
 7,503,145 B2 3/2009 Newbold et al.
 7,524,089 B2 4/2009 Park
 D591,894 S 5/2009 Flank
 7,534,989 B2 5/2009 Suehara et al.
 7,566,154 B2 7/2009 Gloisten et al.
 D599,040 S 8/2009 Alexander et al.
 D600,836 S 9/2009 Hanley et al.
 7,588,359 B2 9/2009 Coushaine et al.
 7,592,583 B2 9/2009 Page et al.
 7,625,105 B1 12/2009 Johnson
 7,628,513 B2 12/2009 Chiu
 7,651,238 B2 1/2010 O'Brien
 7,654,705 B2 2/2010 Czech et al.
 D611,650 S 3/2010 Broekhoff
 7,670,021 B2 3/2010 Chou
 7,677,766 B2 3/2010 Boyer
 D616,118 S 5/2010 Thomas et al.
 7,722,208 B1 5/2010 Dupre et al.
 7,722,227 B2 5/2010 Zhang et al.
 7,748,887 B2 7/2010 Zampini, II et al.
 7,766,518 B2 8/2010 Piepgras et al.
 7,771,082 B2 8/2010 Peng
 7,771,094 B2* 8/2010 Goode H02G 3/20
 362/145
 D624,692 S 9/2010 Mackin et al.
 D625,847 S 10/2010 Maglica
 D625,876 S 10/2010 Chen et al.
 D627,727 S 11/2010 Alexander et al.
 7,828,465 B2 11/2010 Roberge et al.
 7,871,184 B2 1/2011 Peng
 D633,099 S* 2/2011 Van de Ven D15/1
 D633,224 S 2/2011 Lee
 D636,903 S 4/2011 Torenbeek
 D637,339 S 5/2011 Hasan et al.
 D637,340 S 5/2011 Hasan et al.
 7,950,832 B2 5/2011 Tanaka et al.
 D639,499 S 6/2011 Choi et al.
 7,959,332 B2 6/2011 Tickner et al.
 7,967,480 B2 6/2011 Pickard et al.
 D642,317 S* 7/2011 Rashidi D26/74
 7,972,035 B2 7/2011 Boyer
 7,972,043 B2 7/2011 Schutte
 D643,970 S 8/2011 Kim et al.
 D646,011 S 9/2011 Rashidi
 8,038,113 B2 10/2011 Fryzek et al.
 D648,476 S 11/2011 Choi et al.
 D648,477 S 11/2011 Kim et al.
 D650,115 S 12/2011 Kim et al.
 8,070,328 B1 12/2011 Knoble et al.
 8,096,670 B2 1/2012 Trott
 D654,205 S 2/2012 Rashidi
 D656,262 S* 3/2012 Yoshinobu D26/74
 D656,263 S 3/2012 Ogawa et al.
 8,142,057 B2 3/2012 Roos et al.
 8,152,334 B2 4/2012 Krogman
 D658,788 S 5/2012 Dudik et al.
 D658,802 S 5/2012 Chen

(56)

References Cited

U.S. PATENT DOCUMENTS

D659,862 S	5/2012	Tsai	8,870,426 B2	10/2014	Biebl et al.
D659,879 S	5/2012	Rashidi	8,890,414 B2	11/2014	Rowlette, Jr. et al.
D660,814 S	5/2012	Wilson	D721,845 S	1/2015	Lui et al.
8,182,116 B2	5/2012	Zhang et al.	D722,296 S	2/2015	Taylor
8,201,968 B2	6/2012	Maxik et al.	D722,978 S	2/2015	Hagarty
D663,058 S	7/2012	Pan	8,950,898 B2	2/2015	Catalano
D663,466 S	7/2012	Rashidi	D726,363 S	4/2015	Danesh
D664,274 S	7/2012	de Visser et al.	9,039,254 B2	5/2015	Danesh
D664,705 S	7/2012	Kong et al.	D731,689 S	6/2015	Bernard et al.
8,215,805 B2	7/2012	Cogliano et al.	9,062,866 B1	6/2015	Christ et al.
8,220,970 B1	7/2012	Khazi et al.	9,065,264 B2 *	6/2015	Cooper H02G 3/16
8,226,270 B2	7/2012	Yamamoto et al.	9,068,719 B2	6/2015	Van De Ven et al.
D667,155 S	9/2012	Rashidi	9,068,722 B2 *	6/2015	Wronski F21V 17/02
8,262,255 B1	9/2012	Rashidi	D735,012 S *	7/2015	Cowie D8/107
D668,809 S	10/2012	Rashidi	D735,142 S	7/2015	Hagarty
D669,198 S	10/2012	Qui	9,078,299 B2	7/2015	Ashdown
D669,199 S	10/2012	Chuang	D739,590 S	9/2015	Redfern
D669,620 S	10/2012	Rashidi	9,140,441 B2	9/2015	Goelz et al.
8,277,090 B2	10/2012	Fryzek et al.	9,151,457 B2	10/2015	Pickard et al.
8,308,322 B2	11/2012	Santiago et al.	9,151,477 B2	10/2015	Pickard et al.
D673,322 S *	12/2012	Van De Ven D26/113	D742,325 S *	11/2015	Leung D13/152
D673,869 S	1/2013	Yu	9,281,671 B2 *	3/2016	Sathyanarayana H02G 3/08
D676,263 S *	2/2013	Birke D6/695	9,285,103 B2	3/2016	Van De Ven et al.
8,376,593 B2	2/2013	Bazydola et al.	9,291,319 B2	3/2016	Kathawate et al.
D677,417 S	3/2013	Rashidi	9,301,362 B2	3/2016	Dohn et al.
D677,634 S *	3/2013	Korcz D13/152	9,310,038 B2	4/2016	Athalye
D679,047 S	3/2013	Tickner et al.	9,322,543 B2	4/2016	Hussell et al.
8,403,533 B1	3/2013	Paulsel	9,347,655 B2	5/2016	Boomgaarden et al.
8,403,541 B1	3/2013	Rashidi	9,371,966 B2	6/2016	Rowlette, Jr. et al.
D681,259 S	4/2013	Kong	D762,181 S	7/2016	Lin
8,408,759 B1	4/2013	Rashidi	9,395,051 B2	7/2016	Hussell et al.
D683,063 S	5/2013	Lopez et al.	D762,906 S	8/2016	Jeswani et al.
D683,890 S	6/2013	Lopez et al.	D764,079 S	8/2016	Wu
D684,269 S	6/2013	Wang et al.	9,417,506 B1	8/2016	Tirosh
D684,719 S	6/2013	Rashidi	D766,185 S *	9/2016	Hagarty D13/152
D685,118 S	6/2013	Rashidi	D768,325 S	10/2016	Xu
D685,120 S	6/2013	Rashidi	D768,326 S	10/2016	Guzzini
8,454,204 B1	6/2013	Chang et al.	D769,501 S	10/2016	Jeswani et al.
D685,507 S	7/2013	Sun	D770,065 S	10/2016	Tittle
D687,586 S	8/2013	Rashidi	9,476,552 B2	10/2016	Myers et al.
D687,587 S	8/2013	Rashidi	D776,324 S	1/2017	Gierl et al.
D687,588 S	8/2013	Rashidi	9,534,751 B2	1/2017	Maglica et al.
D687,980 S	8/2013	Gravely et al.	D778,241 S	2/2017	Holbrook et al.
D688,405 S	8/2013	Kim et al.	D778,484 S	2/2017	Guzzini
D690,049 S	9/2013	Rashidi	9,581,302 B2	2/2017	Danesh
D690,864 S	10/2013	Rashidi	9,599,315 B1	3/2017	Harpenau et al.
D690,865 S	10/2013	Rashidi	9,605,910 B2	3/2017	Swedberg et al.
D690,866 S	10/2013	Rashidi	D785,228 S	4/2017	Guzzini
D691,314 S	10/2013	Rashidi	D786,472 S	5/2017	Redfern
D691,315 S	10/2013	Samson	D786,474 S	5/2017	Fujisawa
8,550,669 B2	10/2013	Macwan et al.	D788,330 S	5/2017	Johnson et al.
D693,043 S	11/2013	Schmalfuss et al.	D790,102 S	6/2017	Guzzini
D693,517 S	11/2013	Davis	9,673,597 B2	6/2017	Lee
D694,456 S	11/2013	Rowlette, Jr. et al.	D791,711 S *	7/2017	Holton D13/152
D695,441 S	12/2013	Lui et al.	D791,996 S *	7/2017	Holscher D26/74
D696,446 S	12/2013	Huh	9,702,516 B1	7/2017	Vasquez et al.
D696,447 S	12/2013	Huh	9,791,111 B1	10/2017	Huang et al.
D696,448 S	12/2013	Huh	9,803,839 B2	10/2017	Visser et al.
8,602,601 B2	12/2013	Khazi et al.	D805,660 S	12/2017	Creasman et al.
D698,067 S	1/2014	Rashidi	D809,176 S	1/2018	Partington
D698,068 S	1/2014	Rashidi	9,863,619 B2 *	1/2018	Mak F21V 23/002
D698,985 S	2/2014	Lopez et al.	9,964,266 B2 *	5/2018	Danesh F21S 8/02
D699,384 S	2/2014	Rashidi	D820,494 S	6/2018	Cohen
D700,387 S	2/2014	Snell	9,995,441 B2	6/2018	Power et al.
8,641,243 B1	2/2014	Rashidi	2002/0172047 A1	11/2002	Ashley
D701,466 S	3/2014	Clifford et al.	2005/0225966 A1	10/2005	Hartmann et al.
8,672,518 B2	3/2014	Boomgaarden et al.	2005/0227536 A1	10/2005	Gamache et al.
D702,867 S	4/2014	Kim et al.	2005/0237746 A1	10/2005	Yiu
D703,843 S	4/2014	Cheng	2006/0158873 A1	7/2006	Newbold et al.
8,684,569 B2	4/2014	Pickard et al.	2006/0215408 A1	9/2006	Lee
D705,472 S	5/2014	Huh	2007/0035951 A1	2/2007	Tseng
8,727,582 B2	5/2014	Brown et al.	2007/0185675 A1	8/2007	Papamichael et al.
D710,529 S	8/2014	Lopez et al.	2007/0206374 A1	9/2007	Petrakis et al.
8,801,217 B2	8/2014	Oehle et al.	2008/0112168 A1	5/2008	Pickard et al.
D714,989 S	10/2014	Rowlette, Jr. et al.	2008/0112170 A1	5/2008	Trott
			2008/0112171 A1	5/2008	Patti et al.
			2008/0137347 A1	6/2008	Trott et al.
			2008/0165545 A1	7/2008	O'Brien
			2008/0232116 A1	9/2008	Kim

(56)

References Cited

U.S. PATENT DOCUMENTS

2009/0003009 A1 1/2009 Tessnow et al.
 2009/0034261 A1 2/2009 Grove
 2009/0080189 A1 3/2009 Wegner
 2009/0135613 A1 5/2009 Peng
 2009/0141500 A1 6/2009 Peng
 2009/0141508 A1 6/2009 Peng
 2009/0147517 A1 6/2009 Li
 2009/0161356 A1 6/2009 Negley et al.
 2009/0237924 A1 9/2009 Ladewig
 2009/0280695 A1 11/2009 Sekela et al.
 2010/0014282 A1 1/2010 Danesh
 2010/0061108 A1 3/2010 Zhang et al.
 2010/0110690 A1 5/2010 Hsu et al.
 2010/0110698 A1 5/2010 Harwood et al.
 2010/0148673 A1 6/2010 Stewart et al.
 2010/0149822 A1 6/2010 Cogliano et al.
 2010/0244709 A1 9/2010 Steiner et al.
 2010/0246172 A1 9/2010 Liu
 2010/0259919 A1 10/2010 Khazi et al.
 2010/0270903 A1 10/2010 Jao et al.
 2010/0302778 A1 12/2010 Dabiet et al.
 2011/0063831 A1 3/2011 Cook
 2011/0068687 A1 3/2011 Takahasi et al.
 2011/0069499 A1 3/2011 Trott et al.
 2011/0116276 A1 5/2011 Okamura et al.
 2011/0134634 A1 6/2011 Gingrich, III et al.
 2011/0134651 A1 6/2011 Berman
 2011/0170294 A1 7/2011 Mier-Langner et al.
 2011/0194299 A1 8/2011 Crooks et al.
 2011/0216534 A1 9/2011 Tickner et al.
 2011/0226919 A1 9/2011 Fryzek et al.
 2011/0255292 A1 10/2011 Shen
 2011/0267828 A1 11/2011 Bazydola et al.
 2012/0020104 A1 1/2012 Biebl et al.
 2012/0074852 A1 3/2012 Delnoij
 2012/0106176 A1 5/2012 Lopez et al.
 2012/0113642 A1 5/2012 Catalano
 2012/0140442 A1 6/2012 Woo et al.
 2012/0162994 A1 6/2012 Wasniewski et al.
 2012/0182744 A1* 7/2012 Santiago F21S 8/026
 362/365
 2012/0188762 A1 7/2012 Joung et al.
 2012/0243237 A1 9/2012 Toda et al.
 2012/0287625 A1 11/2012 Macwan et al.
 2013/0009552 A1 1/2013 Page
 2013/0010476 A1 1/2013 Pickard et al.
 2013/0033872 A1 2/2013 Randolph et al.
 2013/0051012 A1 2/2013 Oehle et al.
 2013/0141913 A1 6/2013 Sachsenweger
 2013/0163254 A1 6/2013 Chang et al.
 2013/0170233 A1 7/2013 Nezu et al.
 2013/0258677 A1 10/2013 Fryzek et al.
 2013/0265750 A1 10/2013 Pickard et al.
 2013/0271989 A1 10/2013 Hussell et al.
 2013/0294084 A1 11/2013 Kathawate et al.
 2013/0301252 A1 11/2013 Hussell et al.
 2013/0322062 A1 12/2013 Danesh
 2014/0036497 A1 2/2014 Hussell et al.
 2014/0049957 A1 2/2014 Goelz et al.
 2014/0071679 A1 3/2014 Booth
 2014/0140490 A1 5/2014 Rowlette, Jr. et al.
 2014/0063818 A1 6/2014 Randolph et al.
 2014/0254177 A1 9/2014 Danesh
 2014/0347848 A1 11/2014 Pisavadia et al.
 2015/0009676 A1* 1/2015 Danesh F21S 8/02
 362/296.01
 2015/0138779 A1 5/2015 Livesay et al.
 2015/0184837 A1 7/2015 Zhang et al.
 2015/0198324 A1 7/2015 O'Brien et al.
 2015/0233556 A1* 8/2015 Danesh F21S 8/02
 362/365
 2015/0263497 A1 9/2015 Korcz et al.
 2015/0276185 A1 10/2015 Bailey et al.
 2015/0362159 A1 12/2015 Ludyjan
 2016/0312987 A1 10/2016 Danesh

2016/0348860 A1 12/2016 Danesh
 2016/0348861 A1 12/2016 Bailey et al.
 2016/0366738 A1 12/2016 Boulanger et al.
 2017/0045213 A1 2/2017 Williams et al.
 2017/0138576 A1* 5/2017 Peng F21S 8/02
 2017/0307188 A1 10/2017 Oudina et al.

FOREIGN PATENT DOCUMENTS

CN 101608781 A 12/2009
 CN 201636626 U 11/2010
 CN 202392473 U 8/2012
 CN 103307518 A 9/2013
 CN 103322476 A 9/2013
 CN 203215483 U 9/2013
 CN 20327663 U 11/2013
 CN 101498411 B 11/2013
 CN 203297980 U 11/2013
 CN 203628464 U 6/2014
 CN 203641919 U 6/2014
 CN 104654142 A 5/2015
 CN 204513161 U 7/2015
 CN 204611541 U 9/2015
 CN 204829578 U 12/2015
 CN 103712135 B 4/2016
 CN 205606362 U 9/2016
 CN 2016130742 U 4/2017
 CN 103154606 B 5/2017
 DE 9109828 U1 2/1992
 EP 1 672 155 A1 6/2006
 EP 2 095 938 A1 2/2008
 EP 2 306 072 A1 4/2011
 EP 2 453 169 A2 5/2012
 EP 2 193 309 B1 7/2012
 GB 2509772 A 7/2014
 JP 2011060450 A2 3/2011
 JP 2012064551 A2 3/2012
 JP 2015002027 A2 1/2015
 JP 2015002028 A2 1/2015
 JP 20171076699 A2 6/2017
 KR 1020110008796 A 1/2011
 KR 1020120061625 A 6/2012
 WO WO 2013/128896 A1 9/2013
 WO WO 2015/000212 A1 1/2015
 WO WO 2016/152116 A2 9/2016

OTHER PUBLICATIONS

Notice of Allowance dated May 10, 2018 from U.S. Appl. No. 14/726,064, 7 pages.
 Acrich COB Zhaga Module, Product Description, Seoul Semiconductor, Nov. 2016, 39 pages.
 <<https://www.zhagastandard.org/books/book18/>>, Mar. 2017, 5 pages.
 Notice of Allowance dated May 22, 2018 from U.S. Appl. No. 14/183,424, 9 pages.
 2006 International Building Code, Section 712 Penetrations, 2006, 4 pages.
 BXUV.GuideInfo, Fire Resistance Ratings—ANSI/UL 263, UL Online Certifications Directory, last updated Nov. 3, 2016, 27 pages.
 CEYY.GuideInfo, Outlet Boxes and Fittings Certified for Fire Resistance, UL Online Certifications Directory, last updated May 16, 2013, 2 pages.
 Canadian Office Action dated Dec. 23, 2013 from Canadian Application No. 2,778,581, 3 pages.
 Canadian Office Action dated Mar. 22, 2016 from Canadian Application No. 2,879,629, 4 pages.
 Canadian Office Action dated Dec. 6, 2016 from Canadian Application No. 2,879,629, 3 pages.
 Canadian Office Action dated Mar. 9, 2017 from Canadian Application No. 2,931,588, 5 pages.
 Canadian Office Action dated Feb. 1, 2016 from Canadian Application No. 2,879,486, 5 pages.
 Canadian Office Action dated Jun. 12, 2017 from Canadian Application No. 2,927,601, 4 pages.

(56)

References Cited

OTHER PUBLICATIONS

Canadian Office Action dated Aug. 11, 2017 from Canadian Application No. 2,941,051, 4 pages.

DMF, Inc., “dmfLIGHTING: LED Recessed Lighting Solutions,” Info sheets, Mar. 15, 2012, 4 pages.

DMF, Inc., “dmfLIGHTING: LED Recessed Downlighting,” DRD2 Product Brochure, Oct. 23, 2014, 50 pages.

DMF, Inc., “dmfLIGHTING: LED Recessed Downlighting,” Product Catalog, Aug. 2012, 68 pages.

Final Office Action dated Apr. 27, 2016 from U.S. Appl. No. 14/184,601, 19 pages.

Final Office Action dated Jul. 26, 2017 from U.S. Appl. No. 14/184,601, 18 pages.

Final Office Action dated Jan. 29, 2016 from U.S. Appl. No. 14/183,424, 21 pages.

Final Office Action dated Jun. 23, 2016 from U.S. Appl. No. 13/484,901, 18 pages.

Final Office Action dated Apr. 2, 2015 from U.S. Appl. No. 13/484,901, 13 pages.

Halo, Halo LED H4 H7 Collection, SustainabLEDesign, Cooper Lighting, (emphasis on p. 18 “H7 Collection LED Modules—Halo LED H7 Module Features,”) Mar. 28, 2012, 52 pages.

Halo, H7 LED Downlight Trims 49x Series, 6-inch LED Trims for Use with MI7x LED Modules, Cooper Lighting, ADV110422, rev. Aug. 12, 2011, 15 pages.

Halo, LED Module ML706x, Cooper Lighting, General Installation for All Modules/p. 1; Tether Installation/pp. 2-3; Installation into Halo H750x Series LED—only (Non-Screw Based), Recessed Fixture, p. 4, Oct. 20, 2009, 4 pages.

“Membrane Penetrations in Fire-Resistance Rated Walls,” https://www.ul.com/wp-content/uploads/2014/04/ul_MembranePenetrations.pdf, Issue 1, 2009, 2 pages.

“Metallic Outlet Boxes,” UL 514A, Underwriters Laboratories, Inc., Feb. 16, 2004 (Title Page Reprinted Aug. 10, 2007), 106 pages.

“Metallic and Non-metallic Outlet Boxes Used in Fire-rated Assembly,” <https://iaeimagazine.org/magazine/2000/09/16/metallic-and-non-metallic-outlet-boxes-used-in-fire-rated-assembly/>, Sep. 16, 2000, 5 pages.

Non-Final Office Action dated Mar. 15, 2010 from U.S. Appl. No. 12/100,148, 8 pages.

Non-Final Office Action dated Apr. 30, 2010 from U.S. Appl. No. 12/173,232, 13 pages.

Non-Final Office Action dated Sep. 5, 2014 from U.S. Appl. No. 13/791,087, 8 pages.

Non-Final Office Action dated Jul. 20, 2015 from U.S. Appl. No. 14/184,601, 16 pages.

Non-Final Office Action dated Dec. 15, 2016 from U.S. Appl. No. 14/184,601, 18 pages.

Non-Final Office Action dated Feb. 6, 2018 from U.S. Appl. No. 15/167,682, 9 pages.

Non-Final Office Action dated Sep. 15, 2015 from U.S. Appl. No. 13/484,901, 16 pages.

Non-Final Office Action dated Oct. 16, 2014 from U.S. Appl. No. 13/484,901, 11 pages.

Non-Final Office Action dated Sep. 6, 2017 from U.S. Appl. No. 14/726,064, 8 pages.

Non-Final Office Action dated May 17, 2017 from U.S. Appl. No. 14/183,424, 20 pages.

Non-Final Office Action dated Jun. 2, 2015 from U.S. Appl. No. 14/183,424, 20 pages.

Notice of Allowance dated Jan. 30, 2015 from U.S. Appl. No. 13/791,087, 9 pages.

Notice of Allowance dated Jan. 16, 2015 from U.S. Appl. No. 29/467,026, 9 pages.

Notice of Allowance dated Oct. 21, 2016 from U.S. Appl. No. 13/484,901, 7 pages.

Notice of Allowance dated Mar. 24, 2016 from U.S. Appl. No. 14/247,149, 8 pages.

Notice of Allowance dated Aug. 23, 2017 from Canadian Application No. 2,879,629, 1 page.

“Outlet Boxes for Use in Fire Rated Assemblies,” https://www.ul.com/wp-content/uploads/2014/04/UI_outletboxes.pdf, 2011, 2 pages.

DME Series Installation Instructions, Oct. 18, 2011, 2 pages.

Carlson® Zip Box® Blue™ Switch and Outlet Boxes, Product Brochure, <http://www.carlonsales.com/brochures.php>, 2006, 22 pages.

Cree LED Lamp Family Sales Sheet—Better light is beautiful light, Apr. 24, 2017, 2 pages.

* cited by examiner

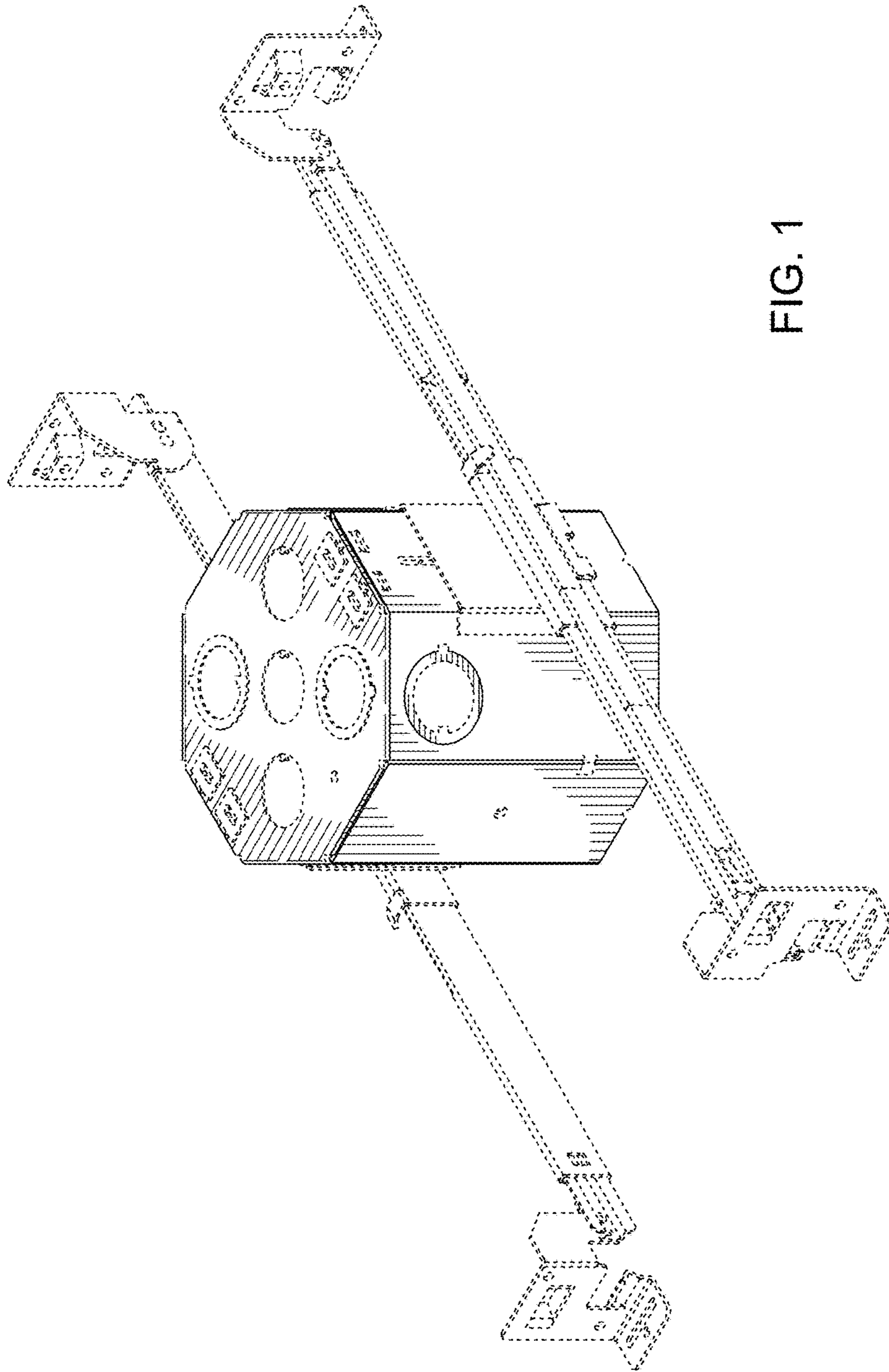

FIG. 1

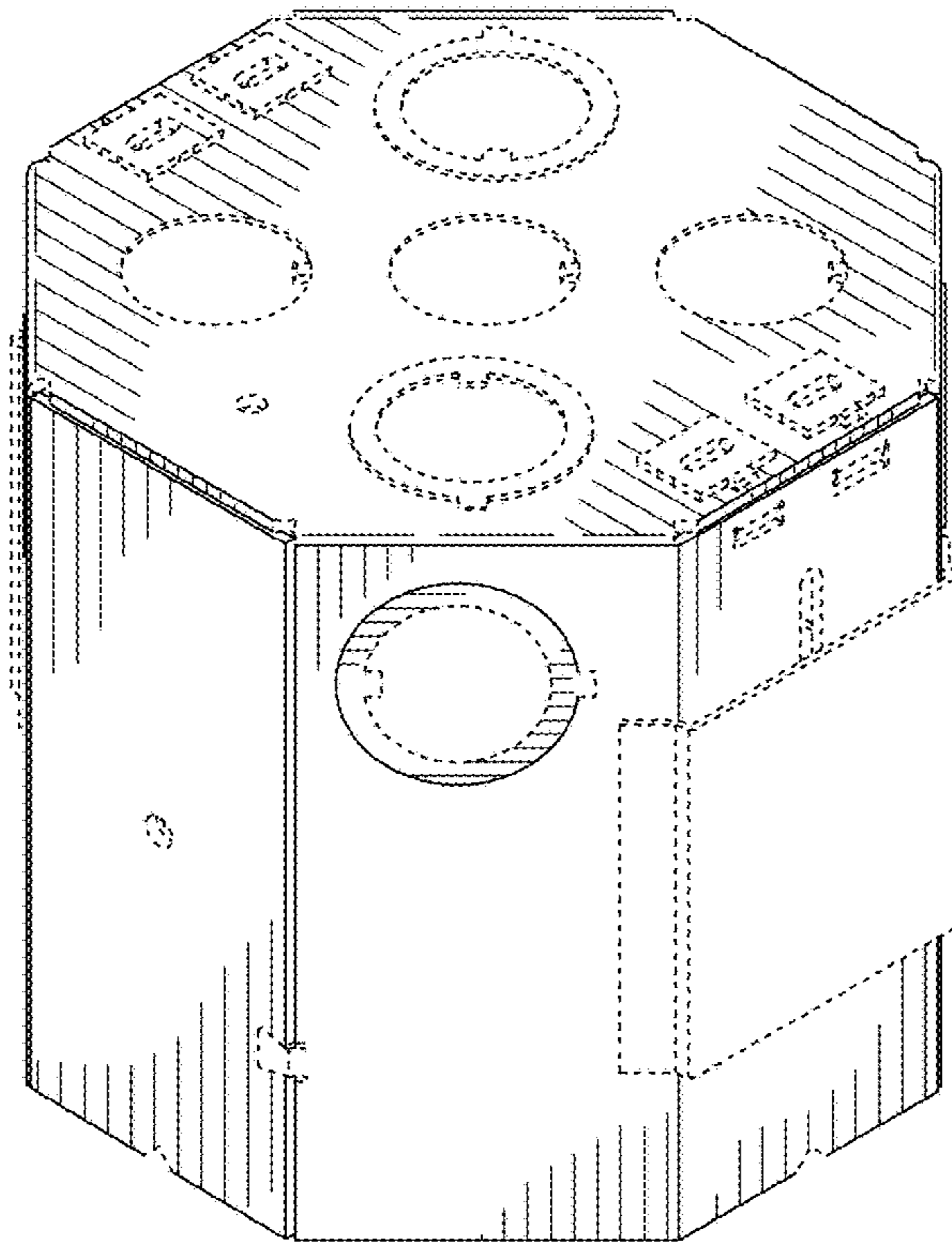

FIG. 2

FIG. 3

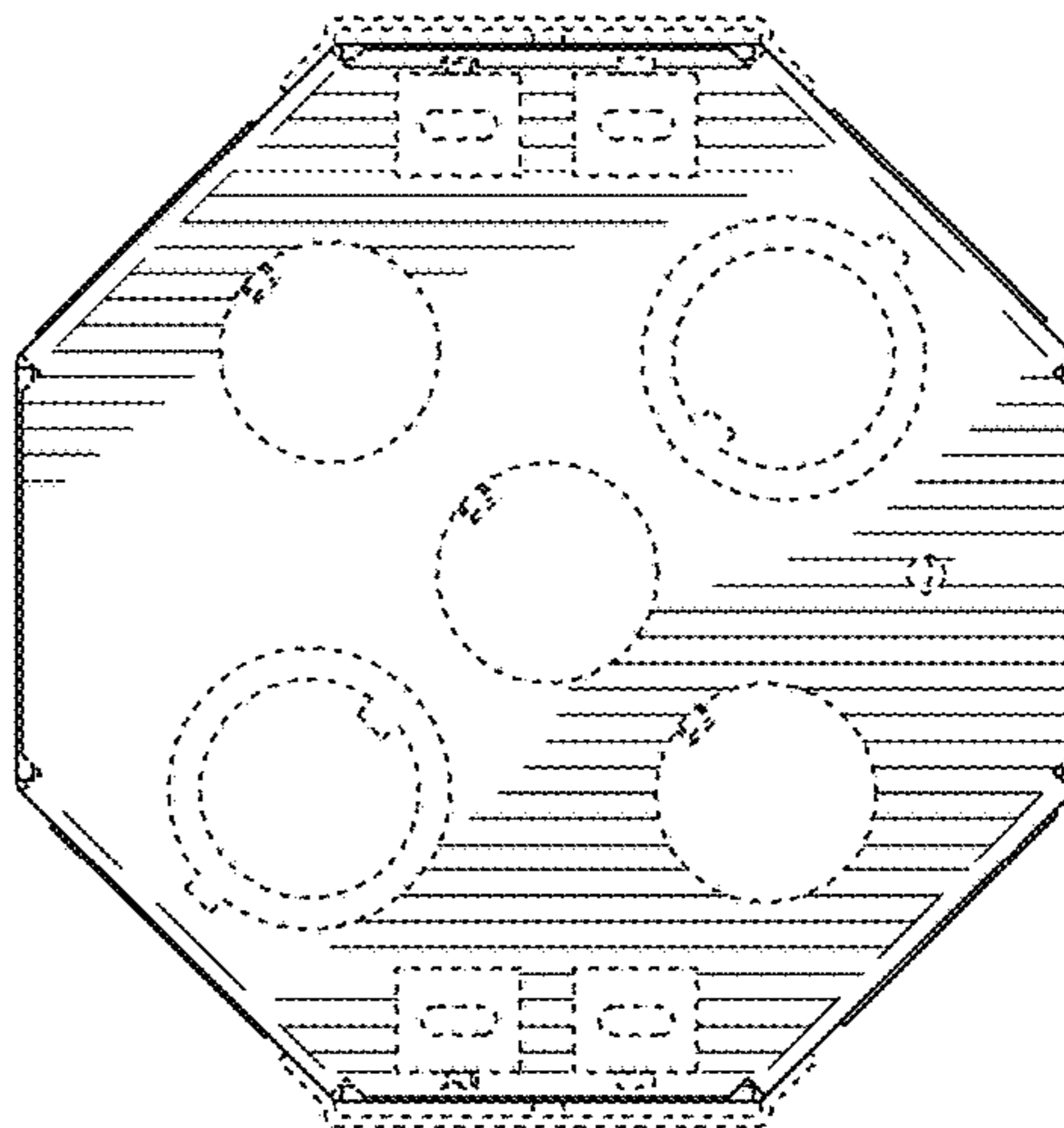

FIG. 4

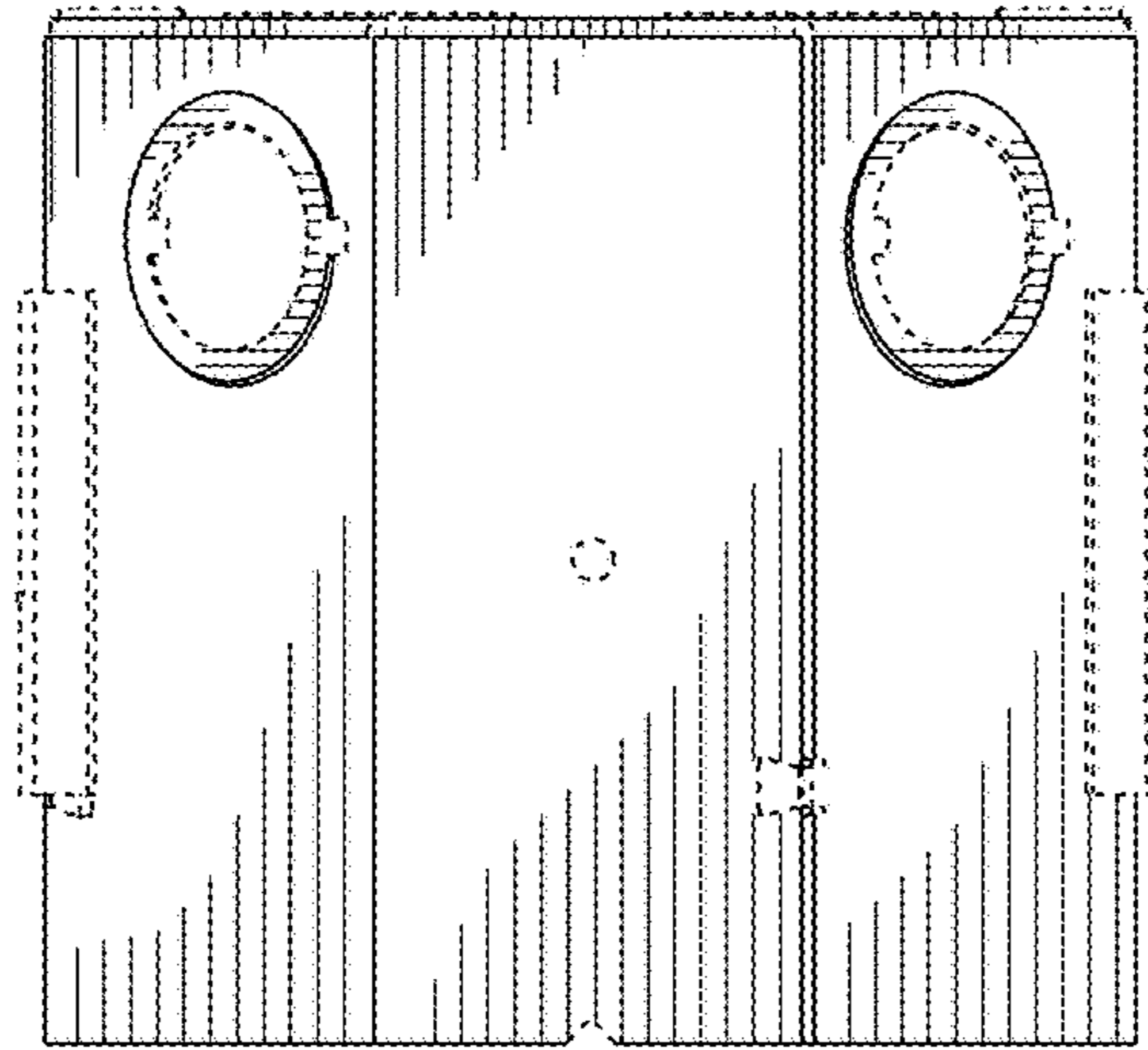

FIG. 5

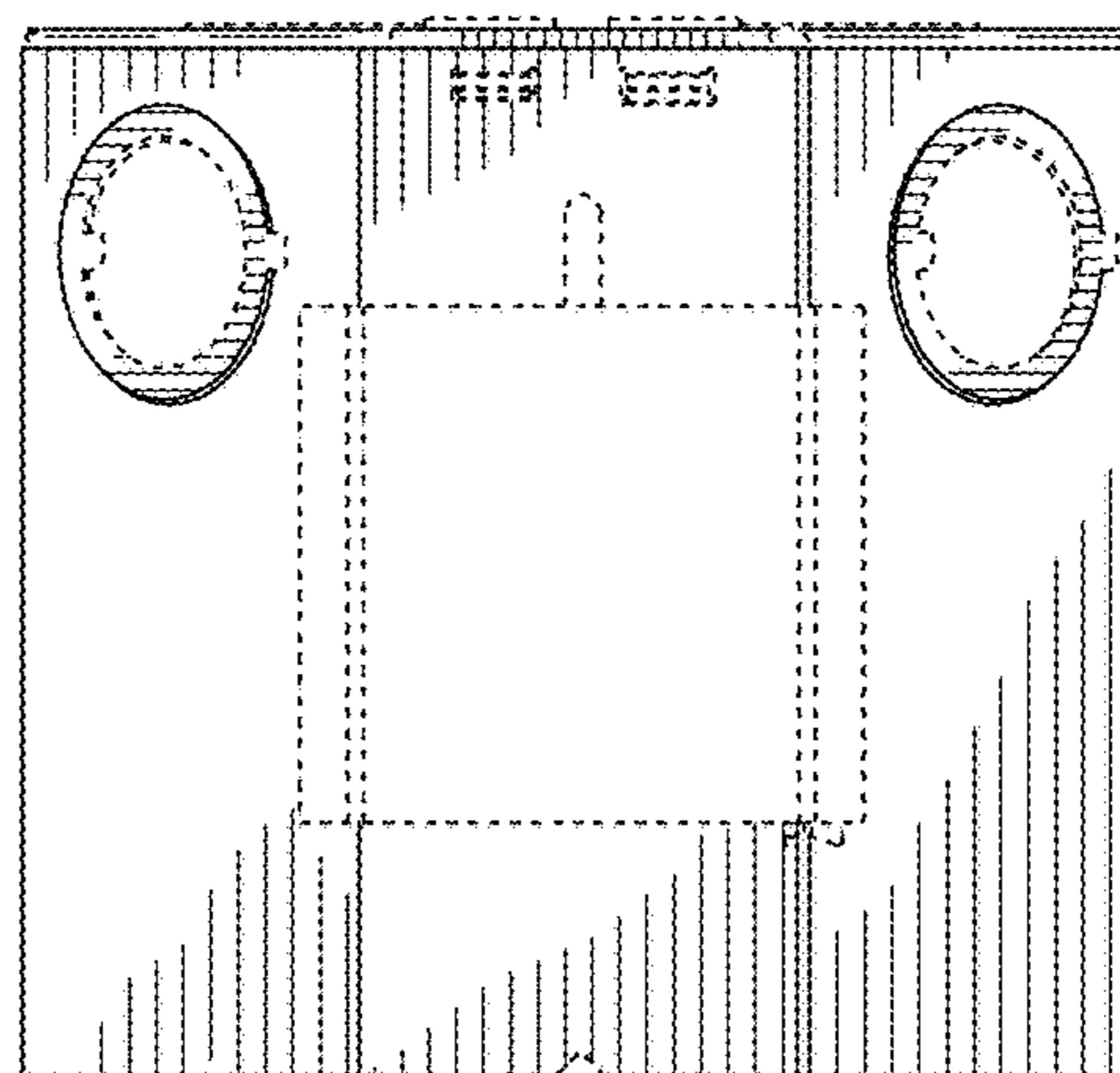

FIG. 6

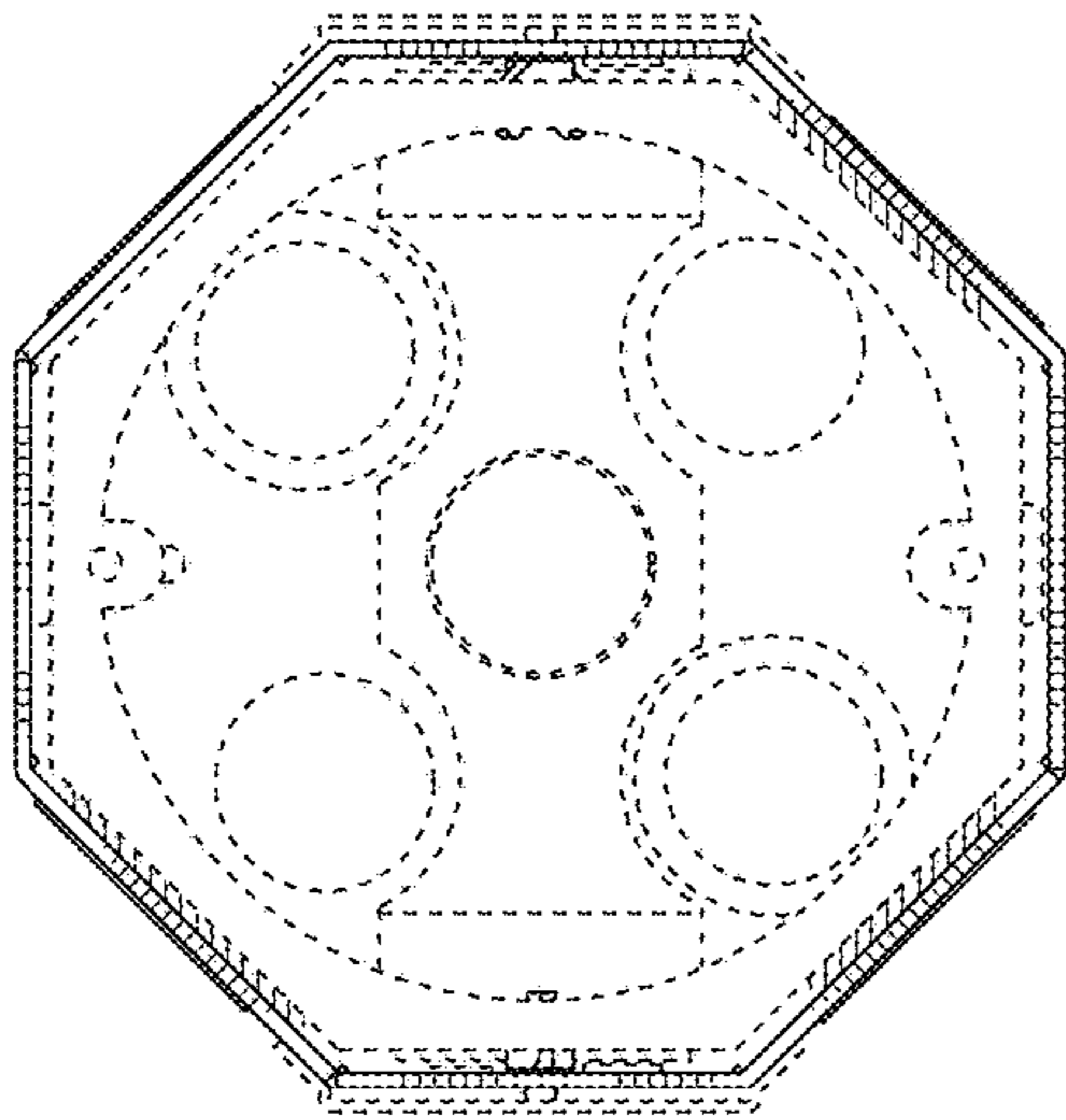
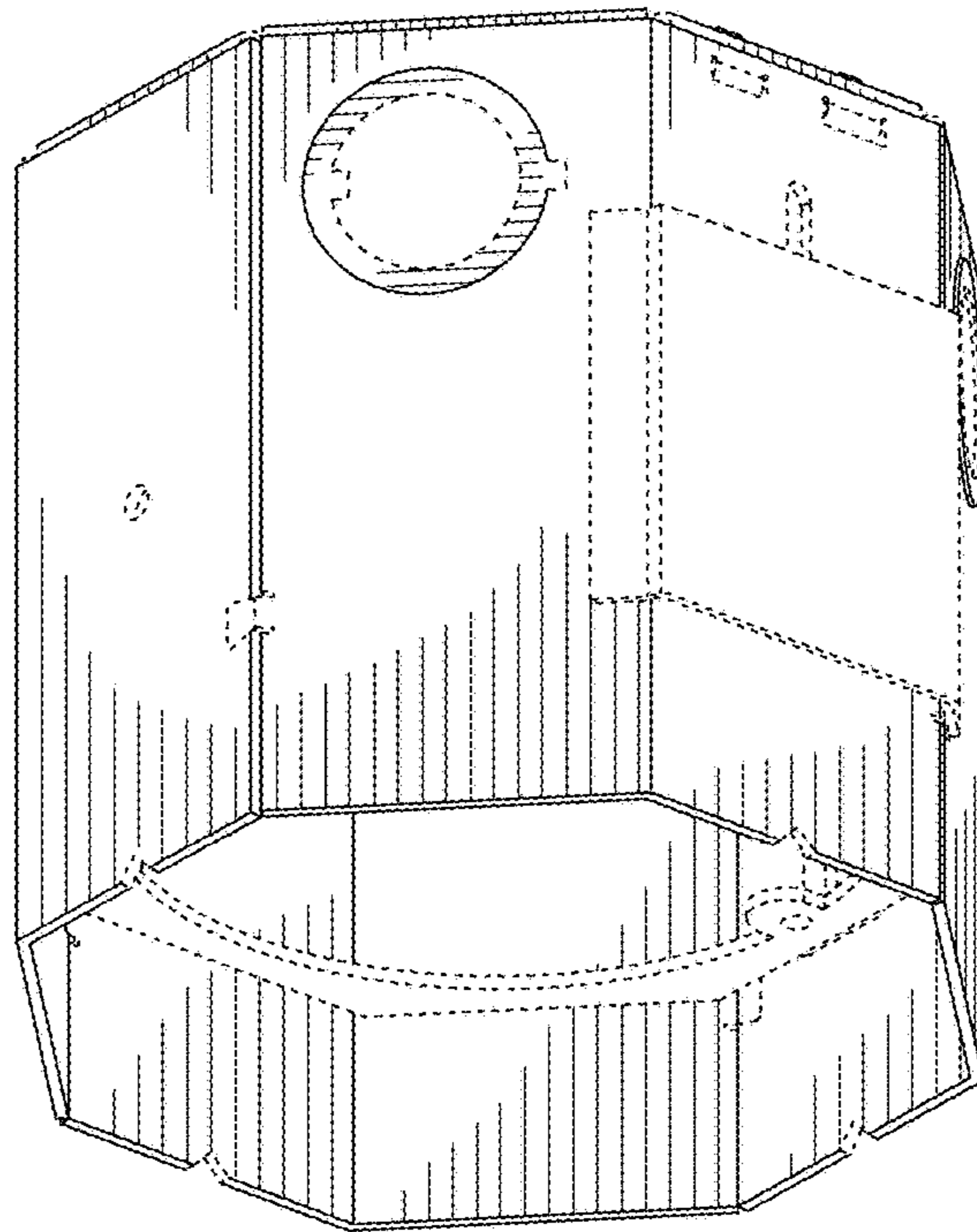

FIG. 7



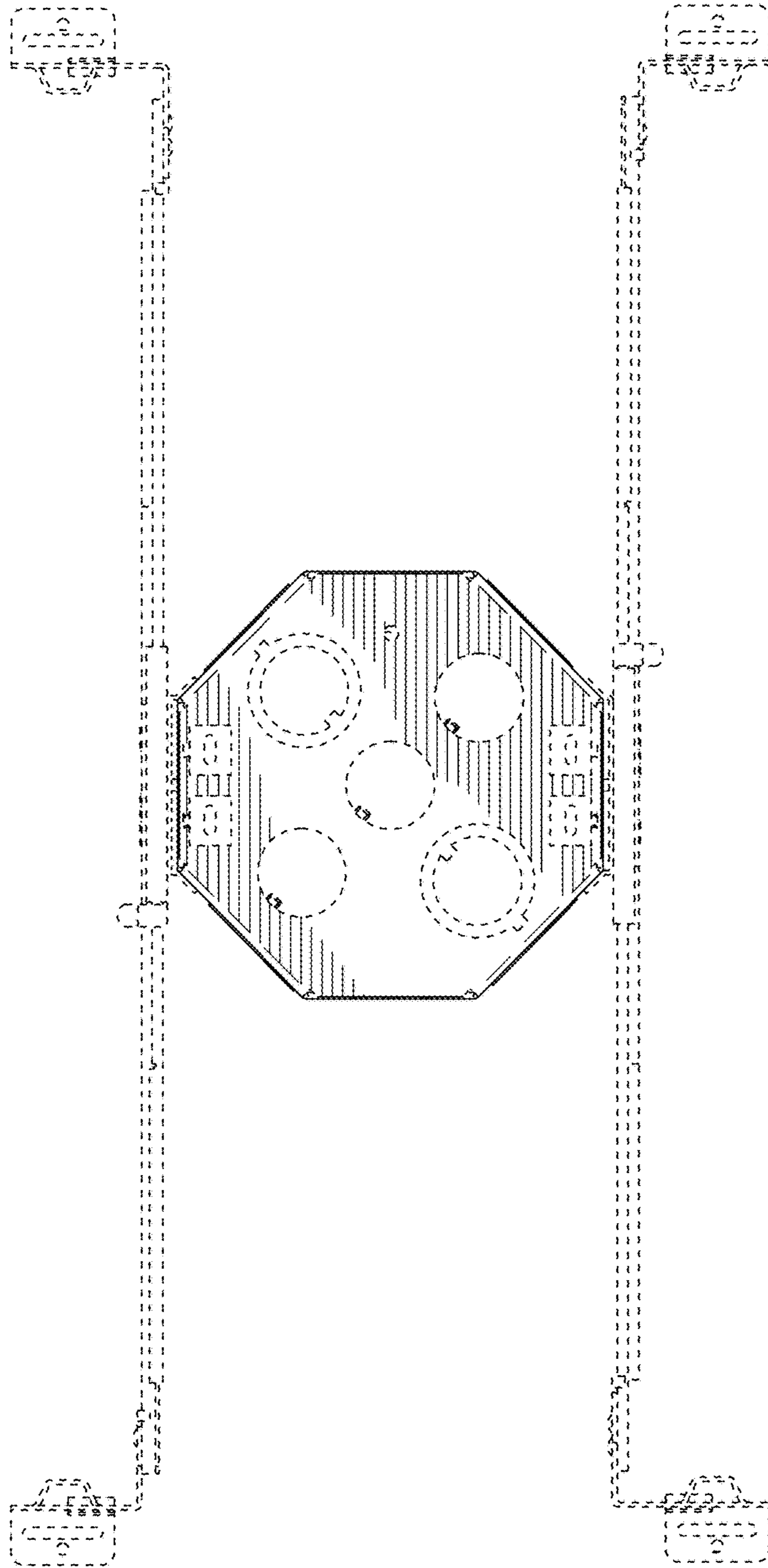

FIG. 8

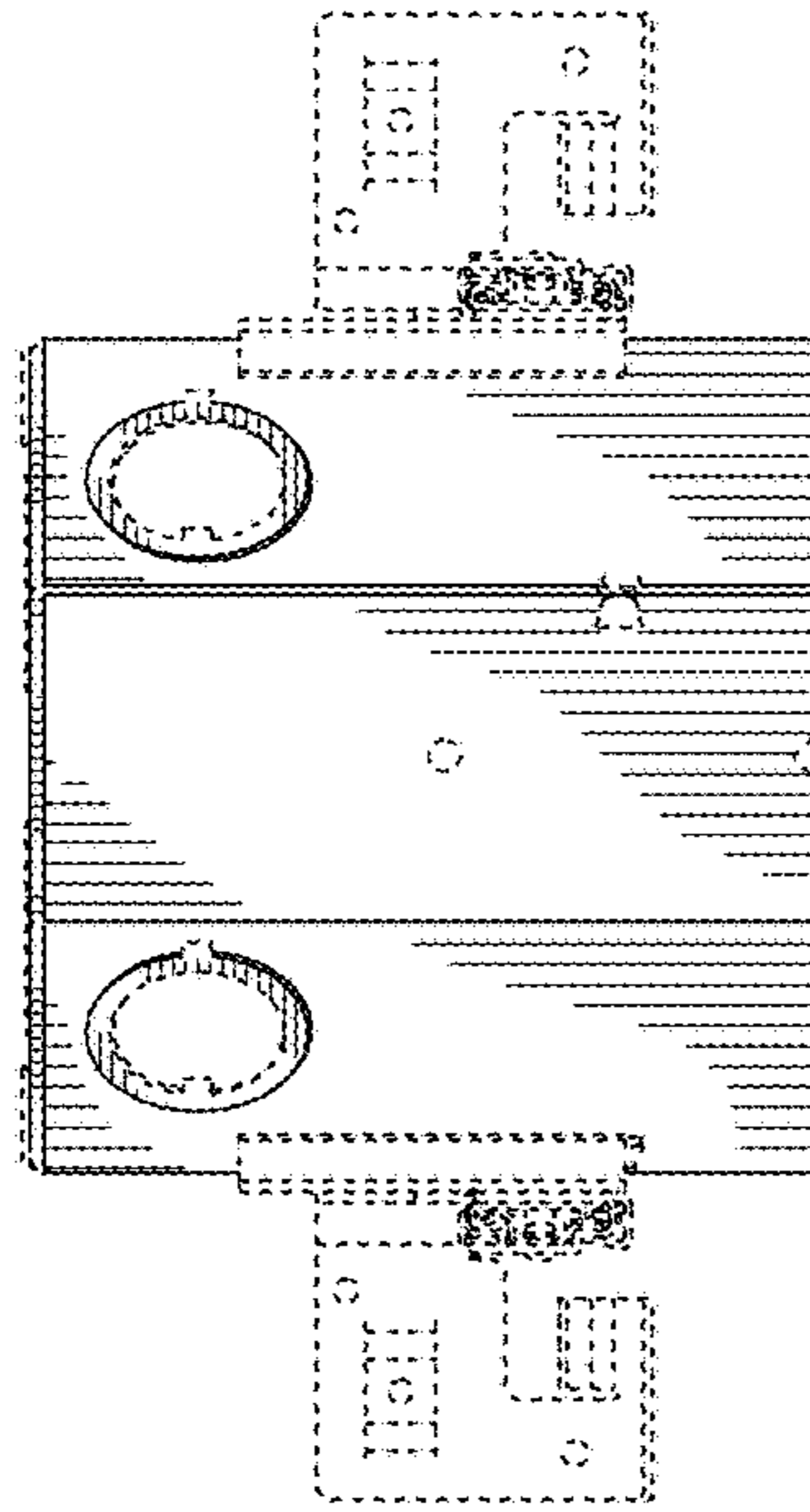

FIG. 9

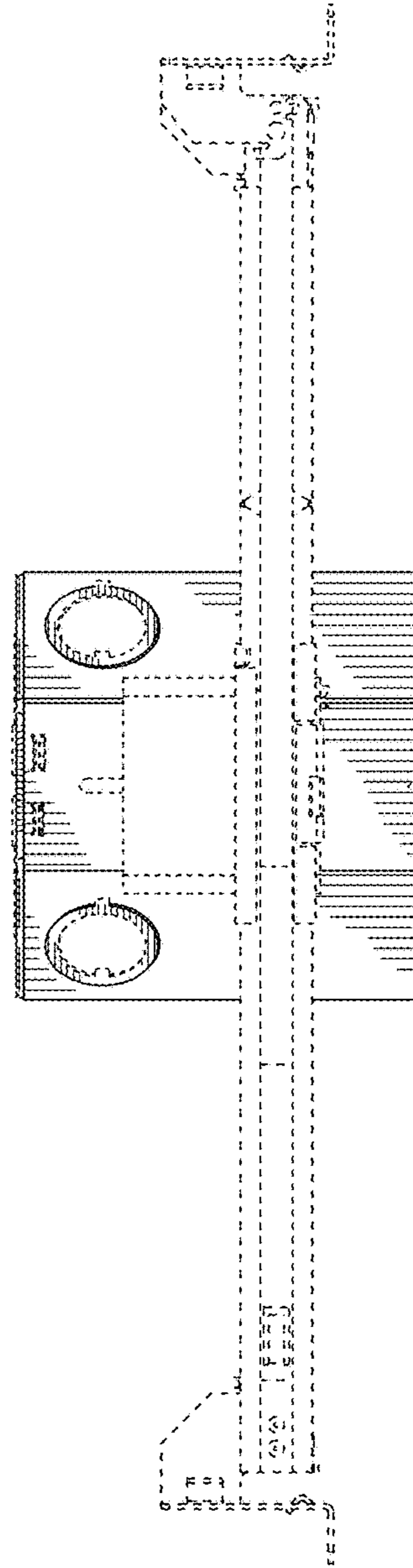

FIG. 10

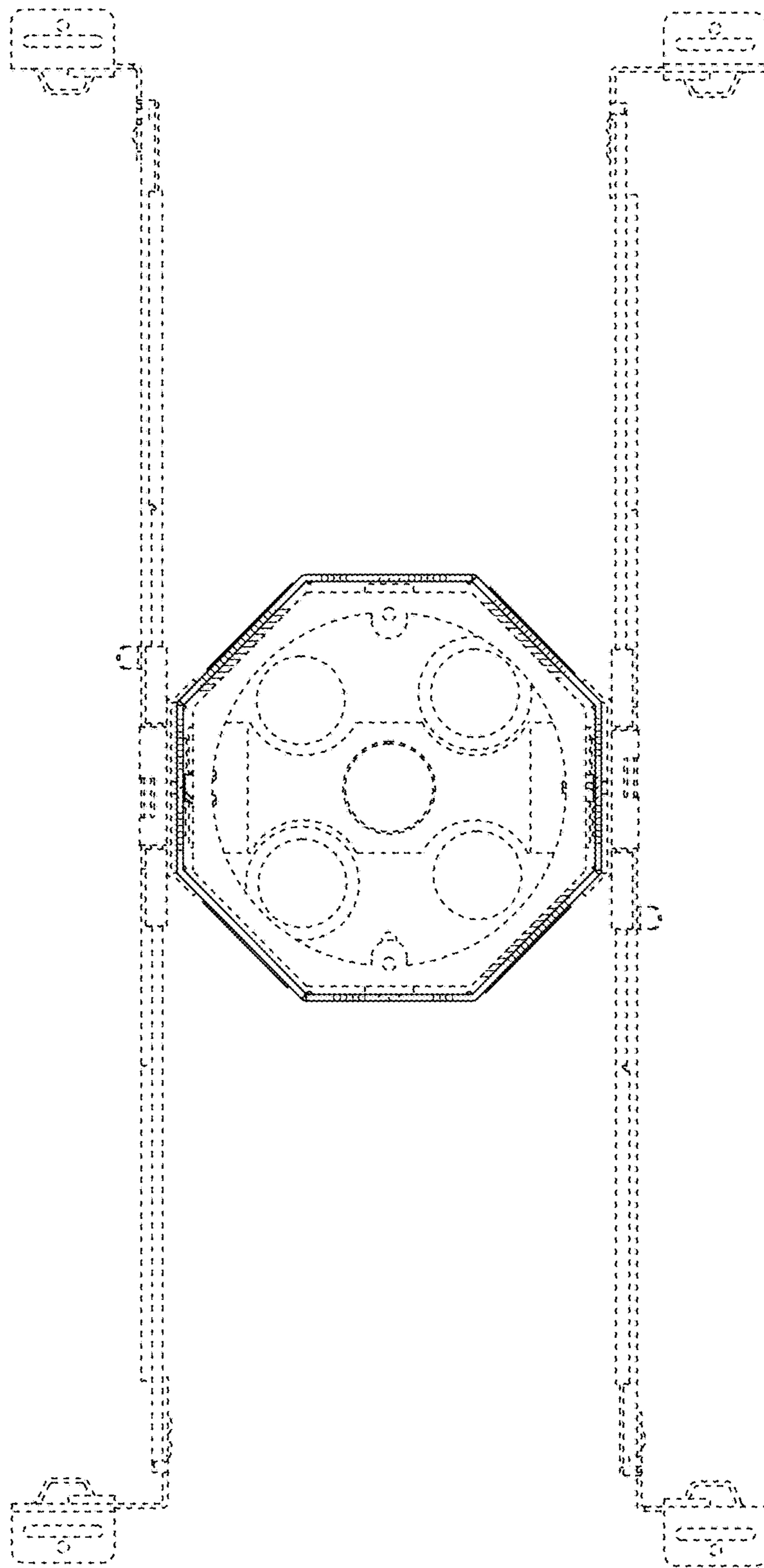

FIG. 11

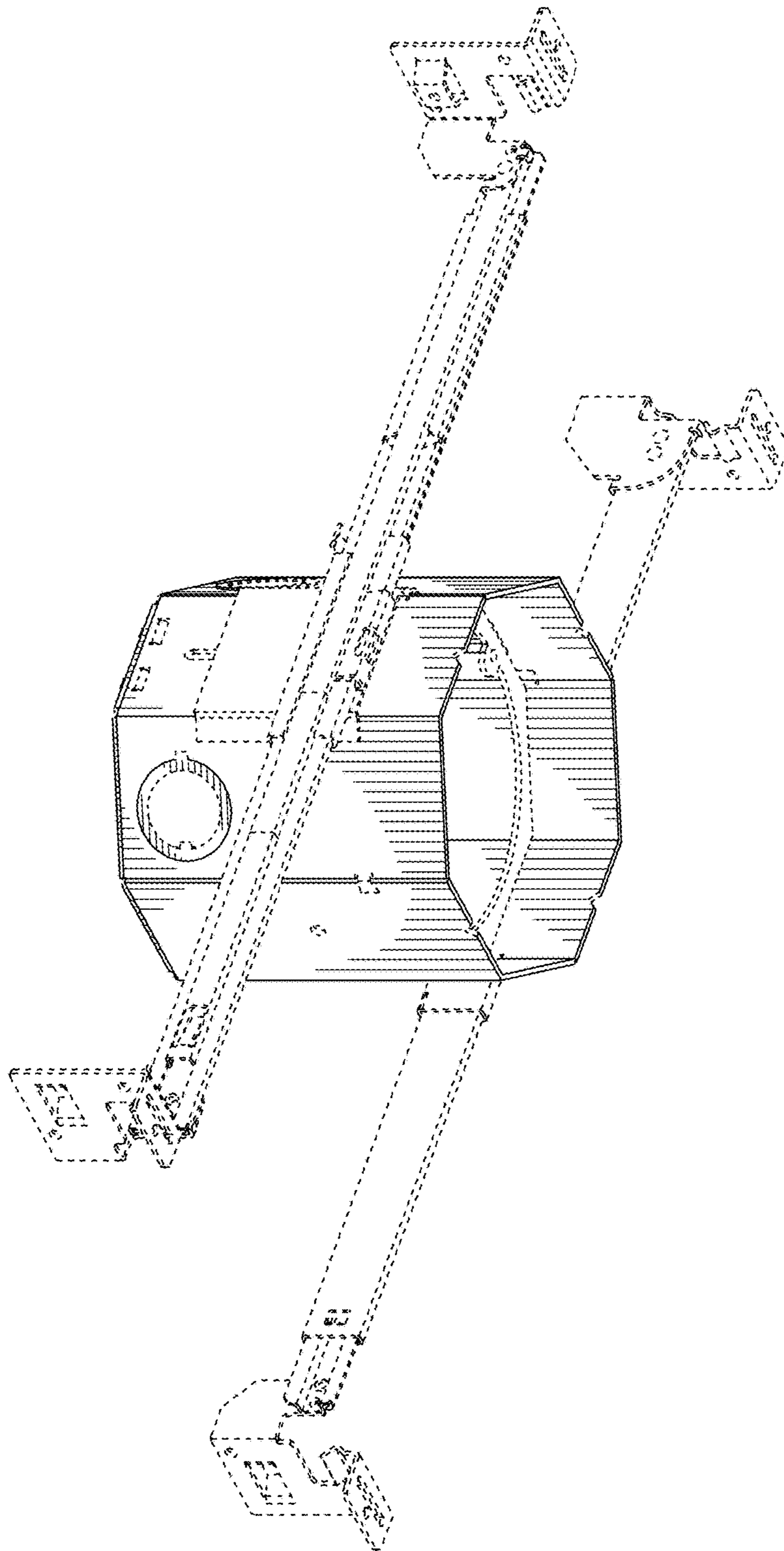

FIG. 12

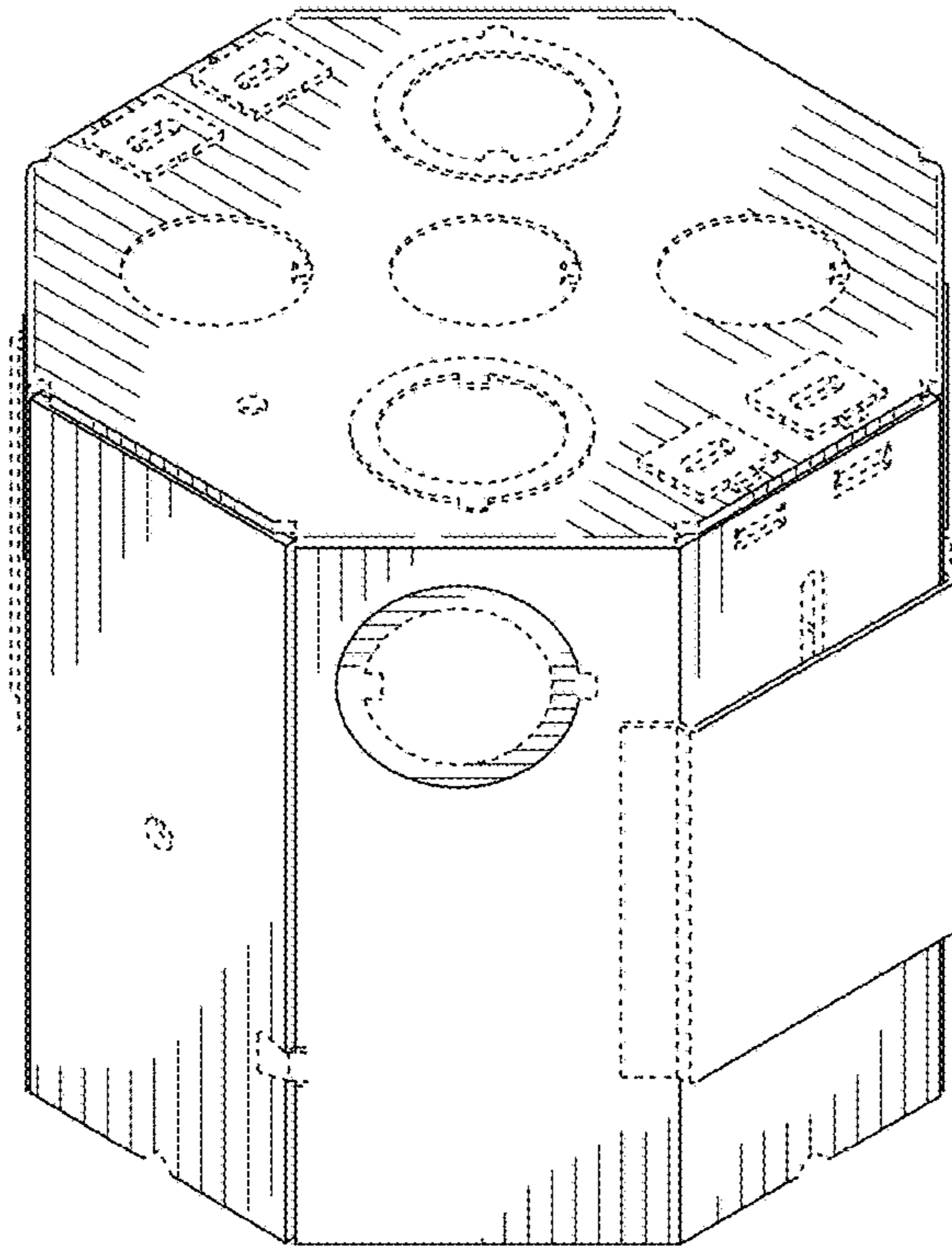

FIG. 13

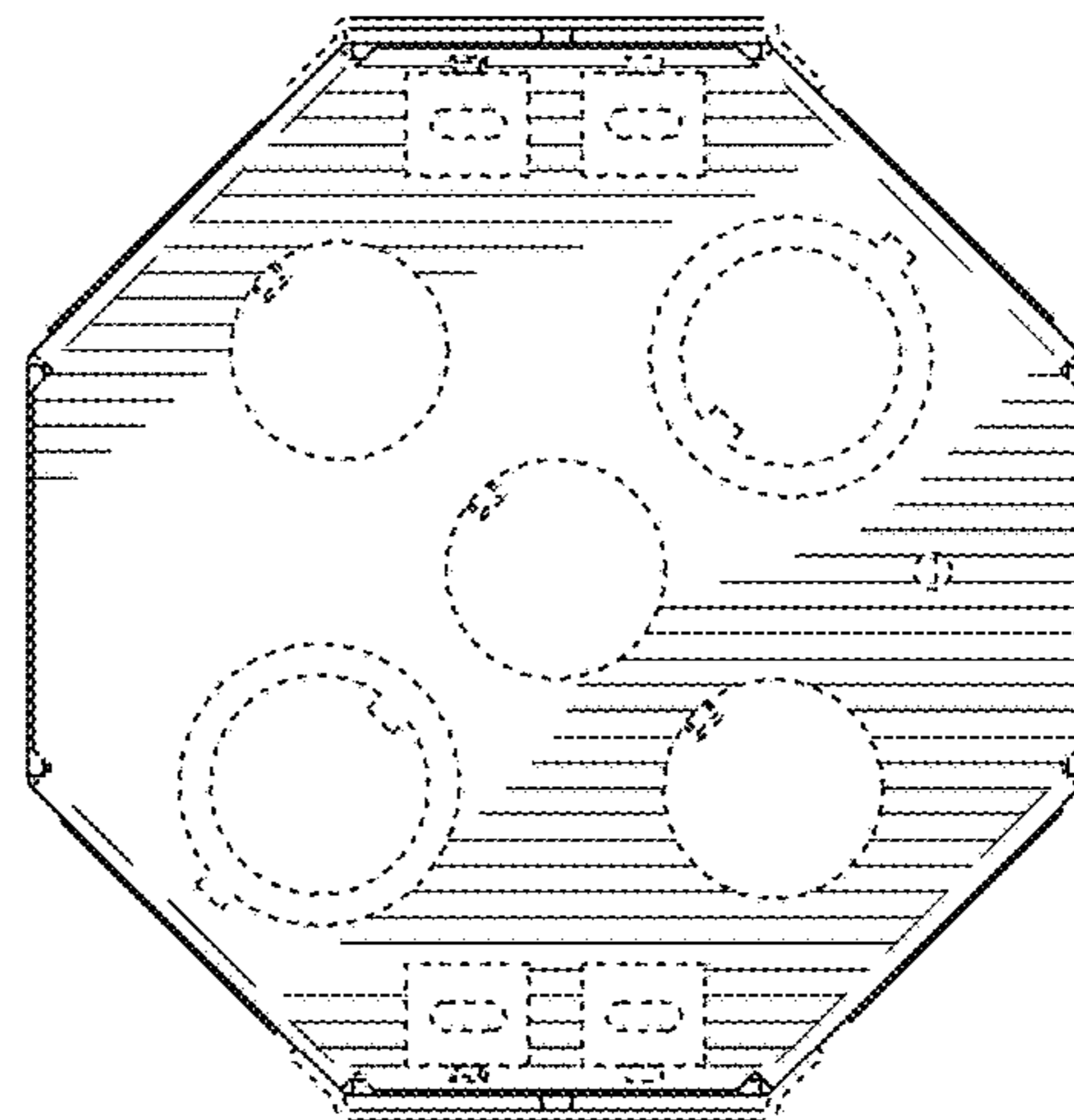

FIG. 14

FIG. 15

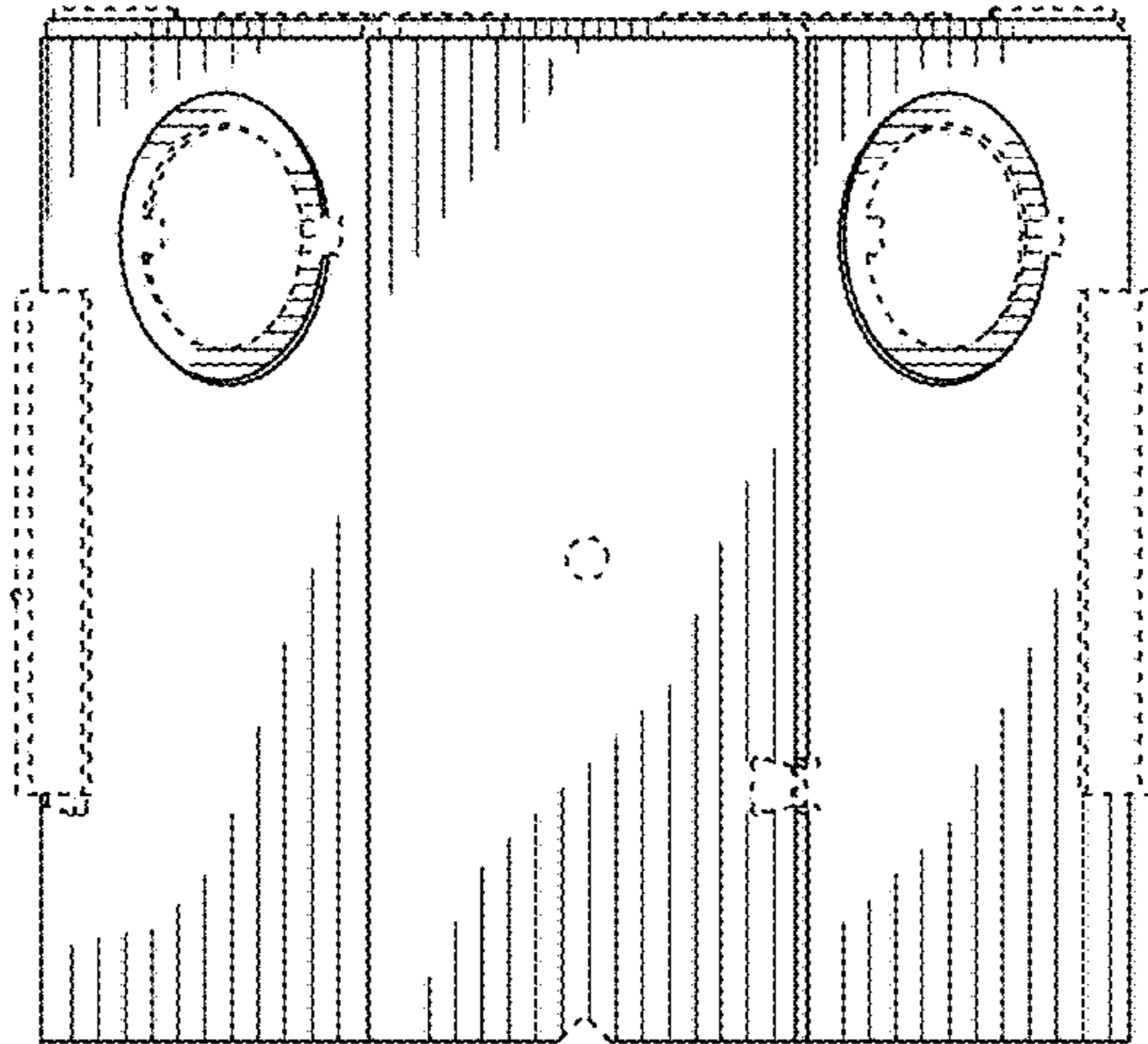

FIG. 16

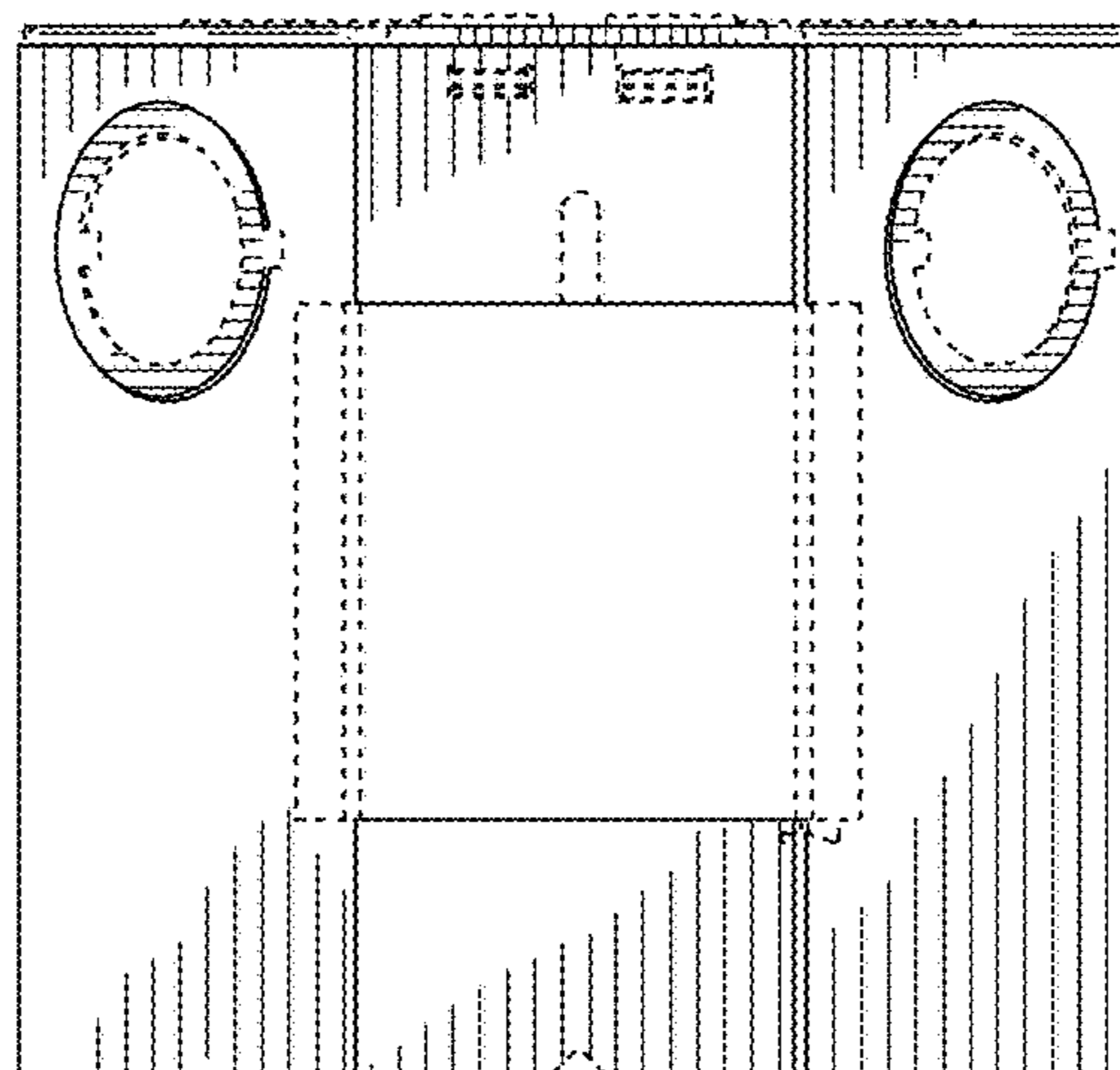

FIG. 17

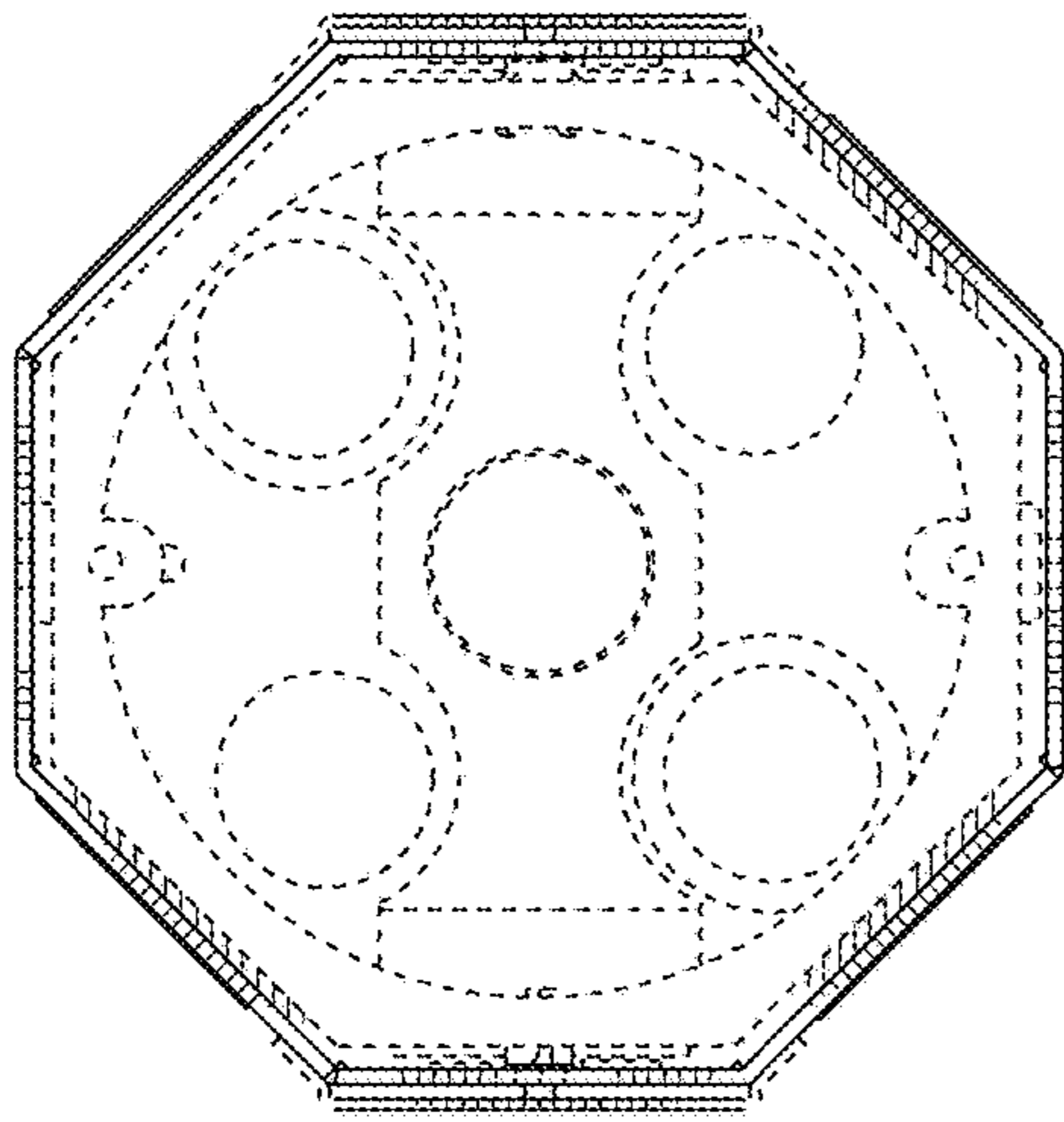

FIG. 18

