



US00D833895S

(12) **United States Design Patent** (10) **Patent No.:** **US D833,895 S**
Aruga (45) **Date of Patent:** **** Nov. 20, 2018**

(54) **PILOT'S EYE POSITION ADJUSTER FOR AIRCRAFT**

(71) Applicant: **Mitsubishi Aircraft Corporation,**
Aichi (JP)

(72) Inventor: **Hiroyasu Aruga,** Tokyo (JP)

(73) Assignee: **MITSUBISHI AIRCRAFT CORPORATION,** Aichi (JP)

(**) Term: **15 Years**

(21) Appl. No.: **29/555,871**

(22) Filed: **Feb. 25, 2016**

(30) **Foreign Application Priority Data**

Oct. 28, 2015 (JP) 2015-023983

Oct. 28, 2015 (JP) 2015-023984

Oct. 28, 2015 (JP) 2015-023985

(51) **LOC (11) Cl.** **10-04**

(52) **U.S. Cl.**
USPC **D10/65; D10/70**

(58) **Field of Classification Search**
USPC **D10/65, 70**

(Continued)

(56) **References Cited**

U.S. PATENT DOCUMENTS

D302,251 S * 7/1989 Dudley D10/74

D315,107 S * 3/1991 Leopoldi D10/70

OTHER PUBLICATIONS

digisco.com Co., Ltd., Web Page Article entitled "DIGISCO.com Website/Product Line-up/DOS-CSI", first page, (<http://www.turboadapter.com/product/doscsi.htm>), available at least as early as Dec. 6, 2012.

* cited by examiner

Primary Examiner — Antoine Duval Davis

(74) *Attorney, Agent, or Firm* — Pearne & Gordon LLP

(57) **CLAIM**

The ornamental design for a pilot's eye position adjuster for aircraft, as shown and described.

DESCRIPTION

FIG. 1 is a perspective view showing the front, left and top side of a first embodiment of a pilot's eye position adjuster for aircraft.

FIG. 2 is a perspective view showing the rear, left and top side thereof.

FIG. 3 is a perspective view showing the front, bottom and left side thereof.

FIG. 4 is a perspective view showing the rear, bottom and left side thereof.

FIG. 5 is a front elevation view thereof.

FIG. 6 is a rear elevation view thereof.

FIG. 7 is a top plan view thereof.

FIG. 8 is a bottom plan view thereof.

FIG. 9 is a left side elevation view thereof.

FIG. 10 is a right side elevation view thereof.

FIG. 11 is a view taken in direction of the arrow 11 in FIG. 9.

FIG. 12 is a perspective view showing the front, left and top side of a second embodiment of a pilot's eye position adjuster for aircraft.

FIG. 13 is a perspective view showing the rear, left and top side thereof.

FIG. 14 is a perspective view showing the front, bottom and left side thereof.

FIG. 15 is a perspective view showing the rear, bottom and left side thereof.

FIG. 16 is a front elevation view thereof.

FIG. 17 is a rear elevation view thereof.

FIG. 18 is a top plan view thereof.

FIG. 19 is a bottom plan view thereof.

FIG. 20 is a left side elevation view thereof.

FIG. 21 is a right side elevation view thereof; and,

FIG. 22 is a view taken in direction of the arrow 22 in FIG. 20.

(Continued)

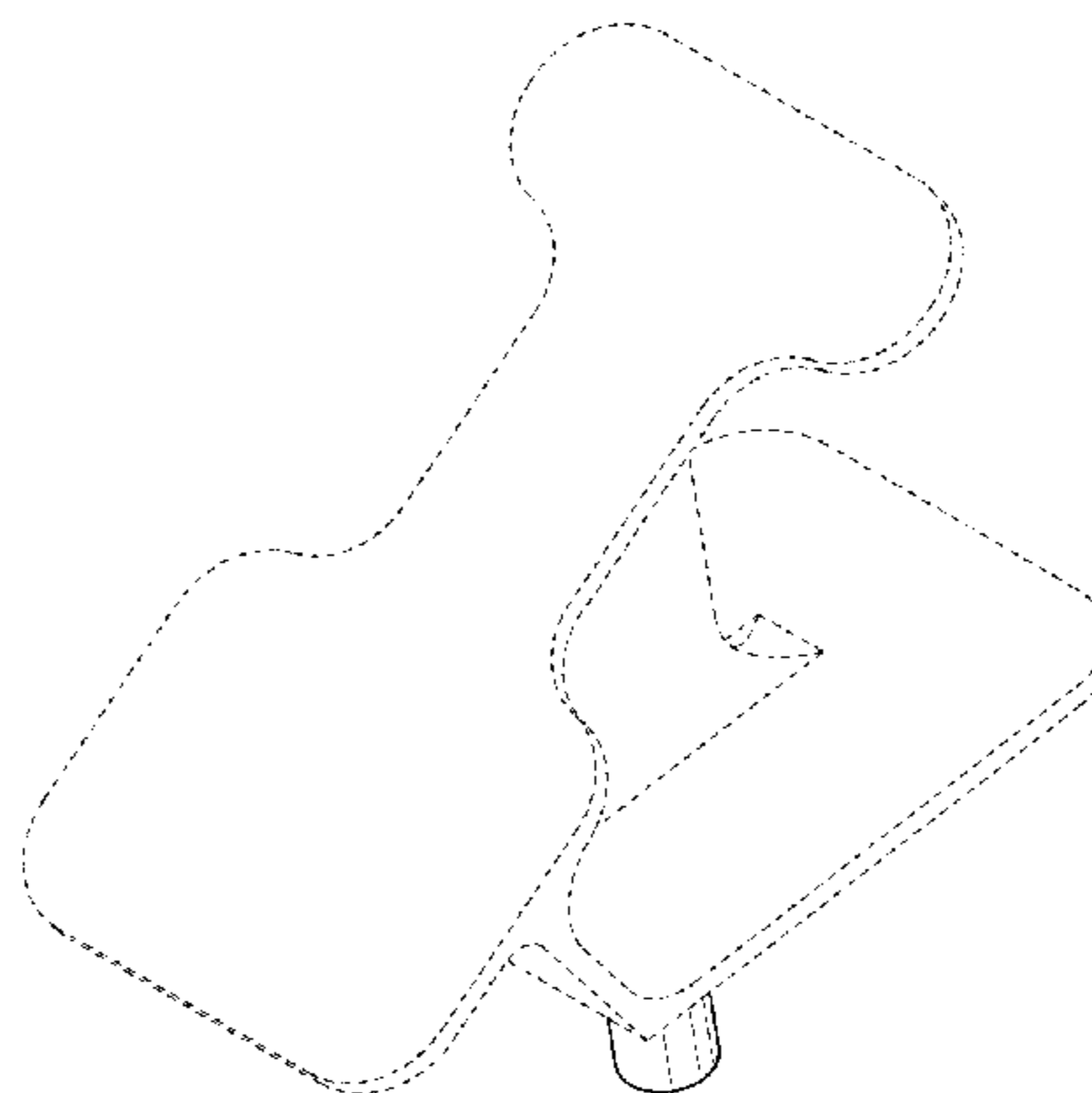
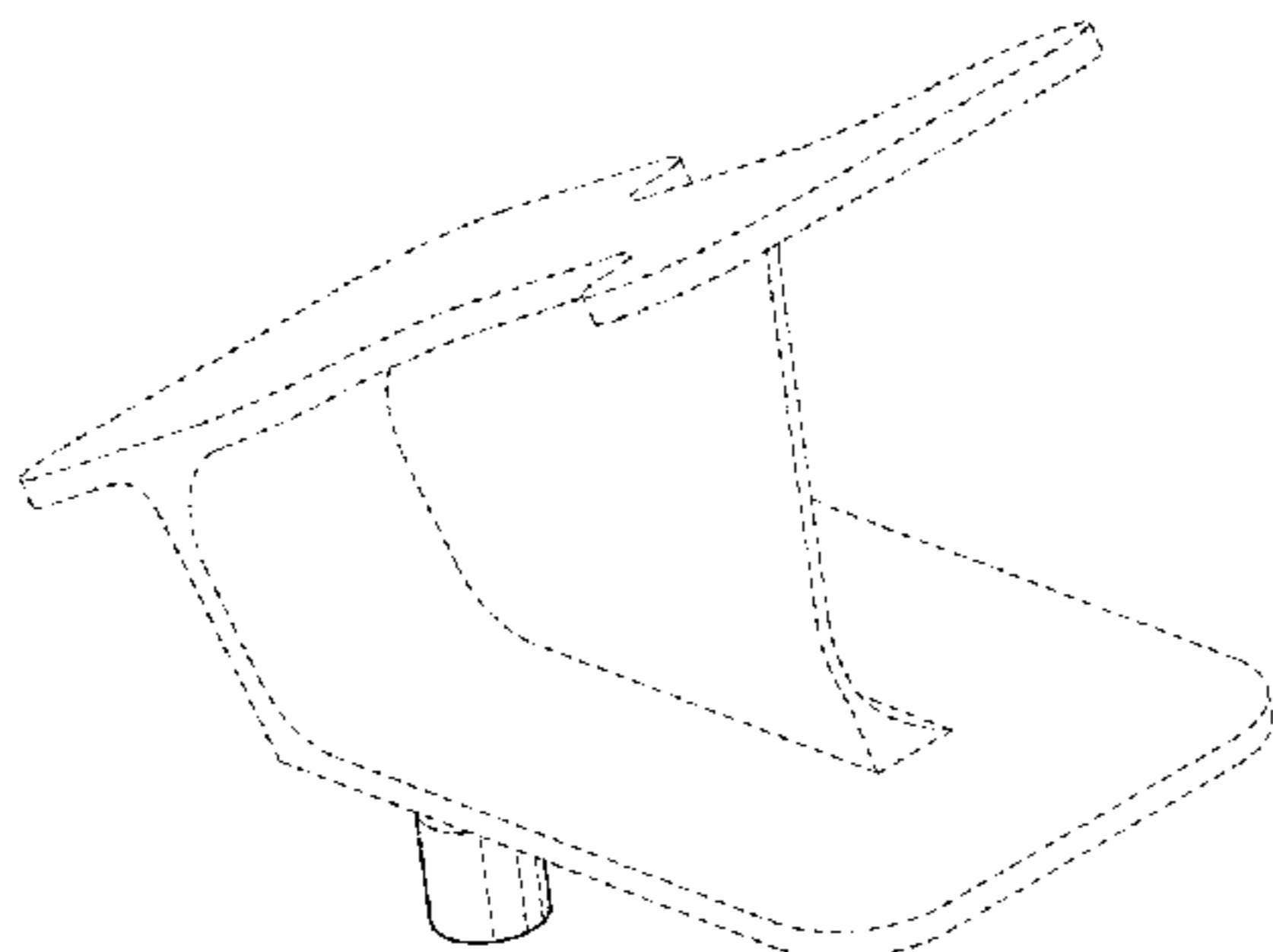

The broken lines shown in the drawings illustrate portions of the pilot's eye position adjuster for aircraft that form no part of the claimed design. The dot-dash lines show an unclaimed boundary which forms no part of the claimed design.

1 Claim, 22 Drawing Sheets

(58) **Field of Classification Search**

CPC A61B 5/107; A61B 5/1071; A61B 5/1072;
A61B 5/1073; A61B 5/1074; A61B
5/1075; A61B 5/1076; A61B 5/1077;
A61B 5/1078; A61B 56/1079; G01B
7/02; G01B 7/004; G01B 7/102; G01B
7/082; G01B 5/008; G01B 5/061; G01B
5/02; G01B 5/08; G01B 5/12; G06F
17/40

See application file for complete search history.

FIG. 1

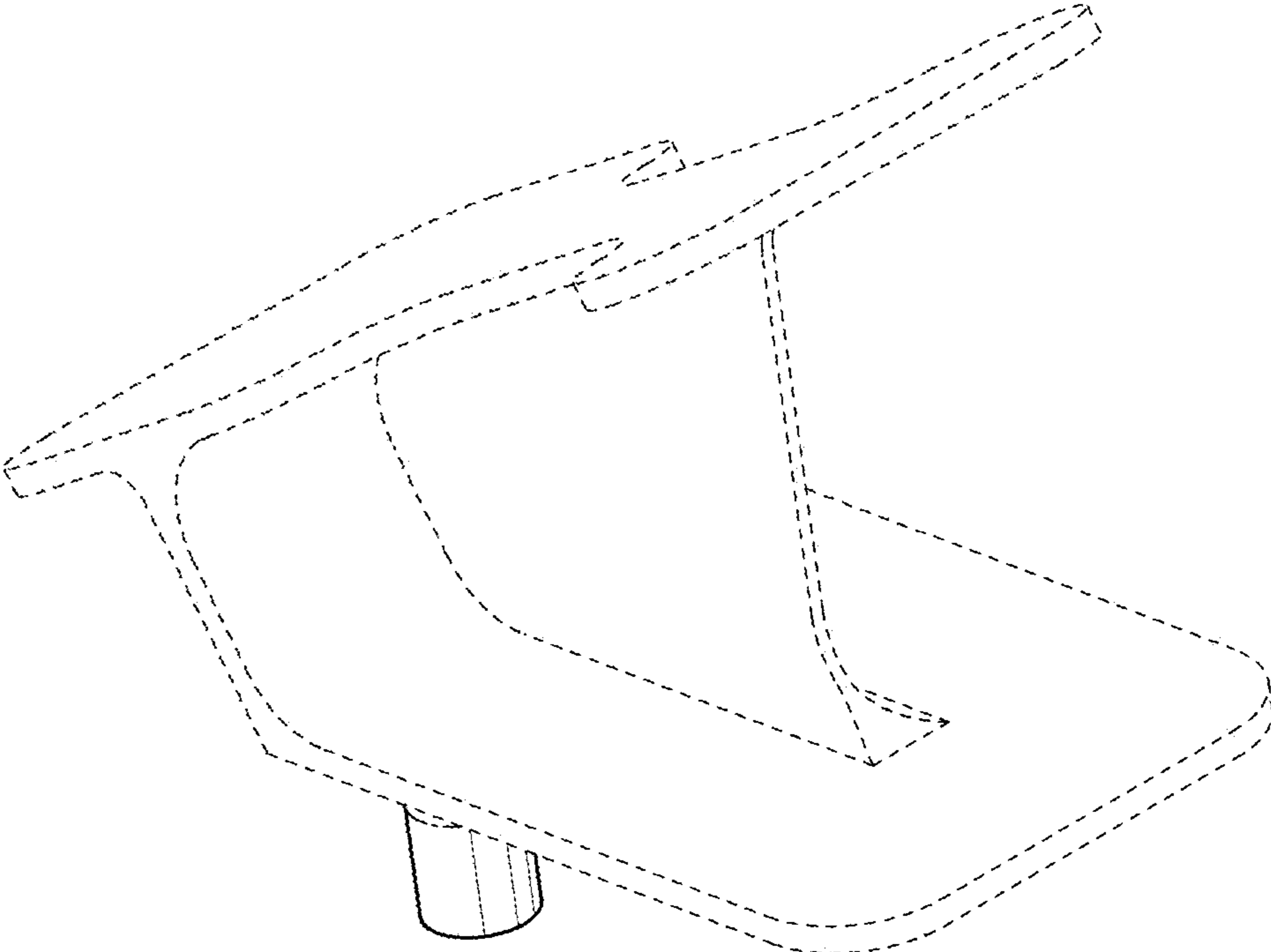

FIG. 2

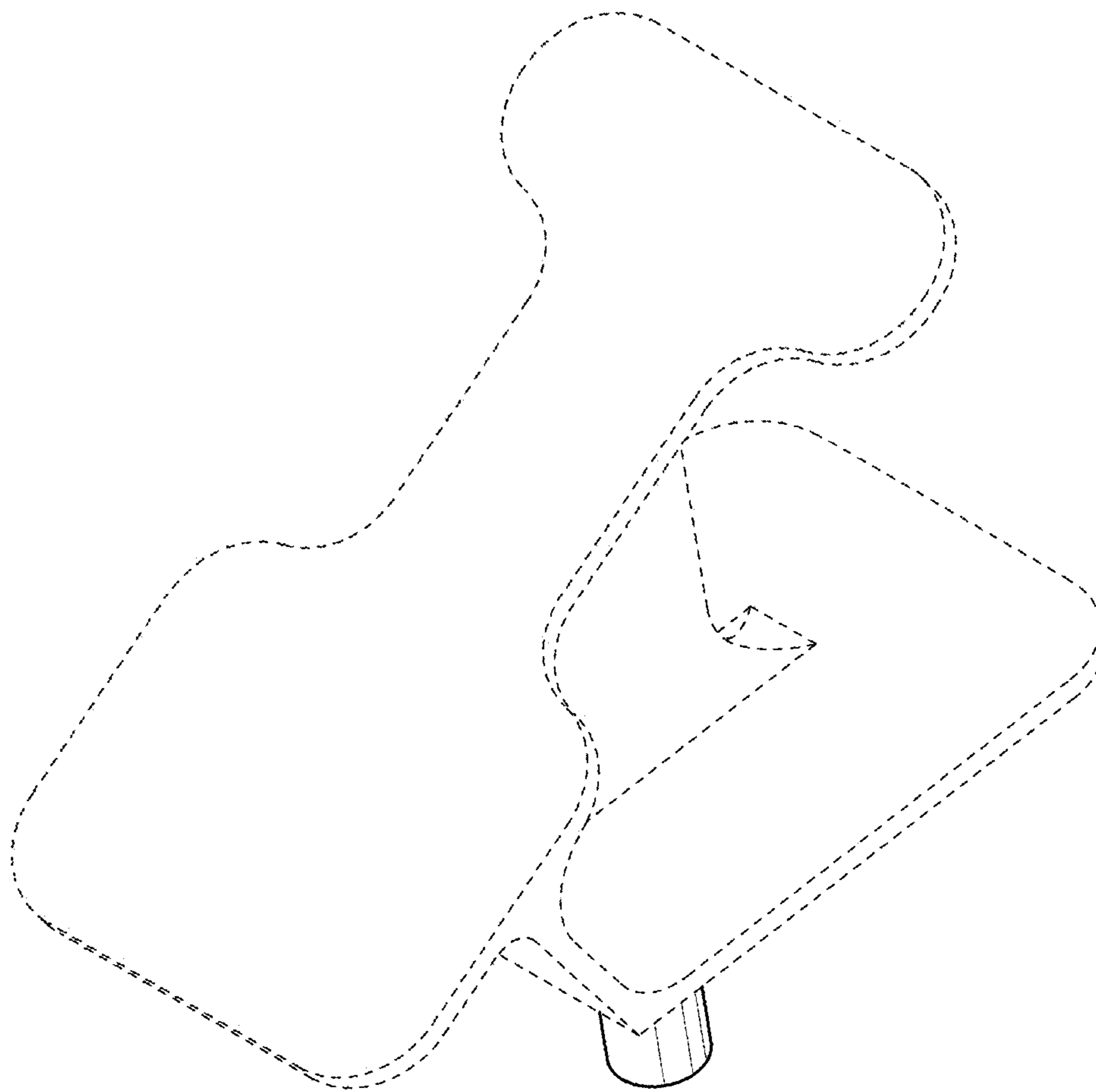

FIG. 3

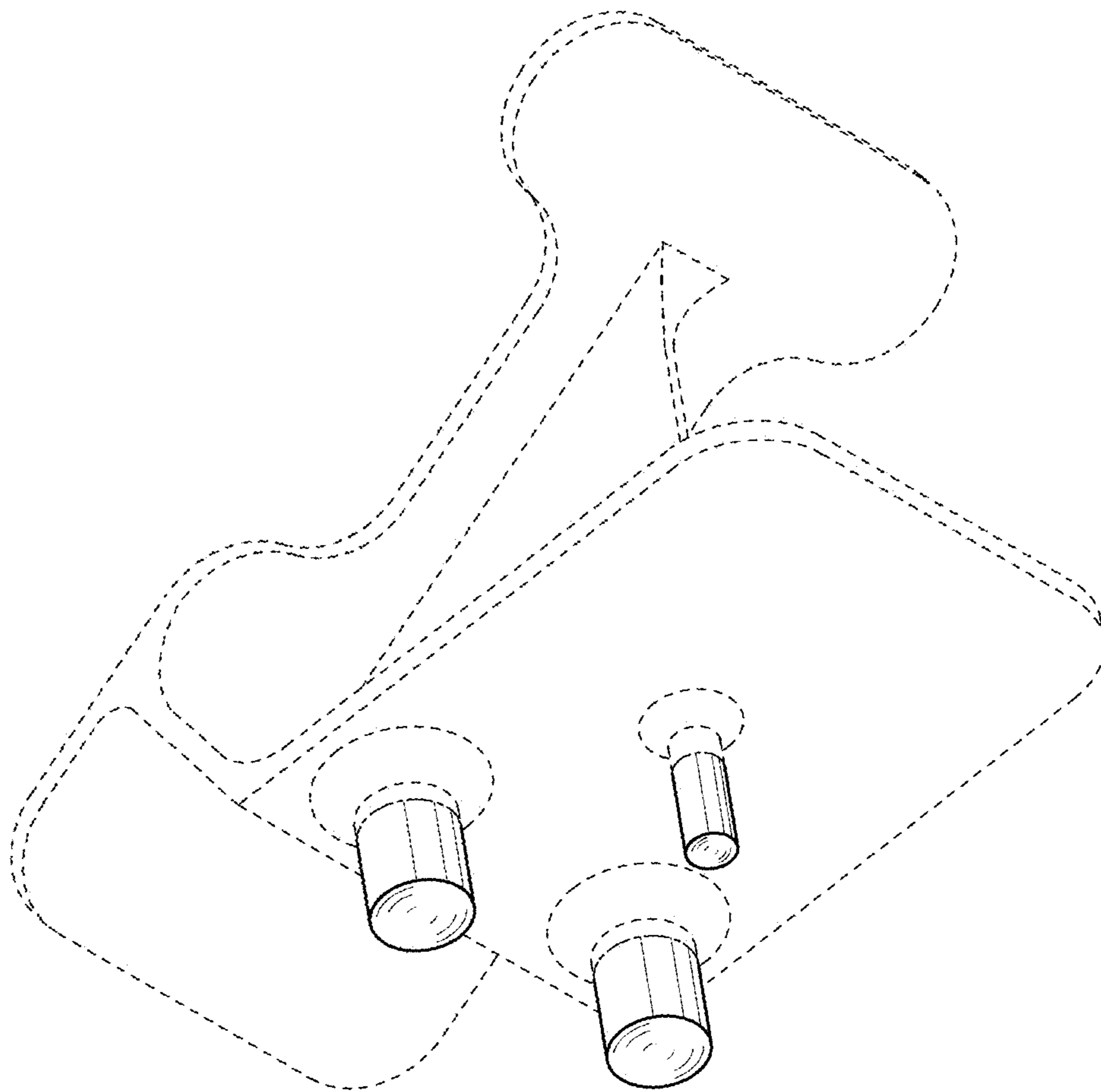

FIG. 4

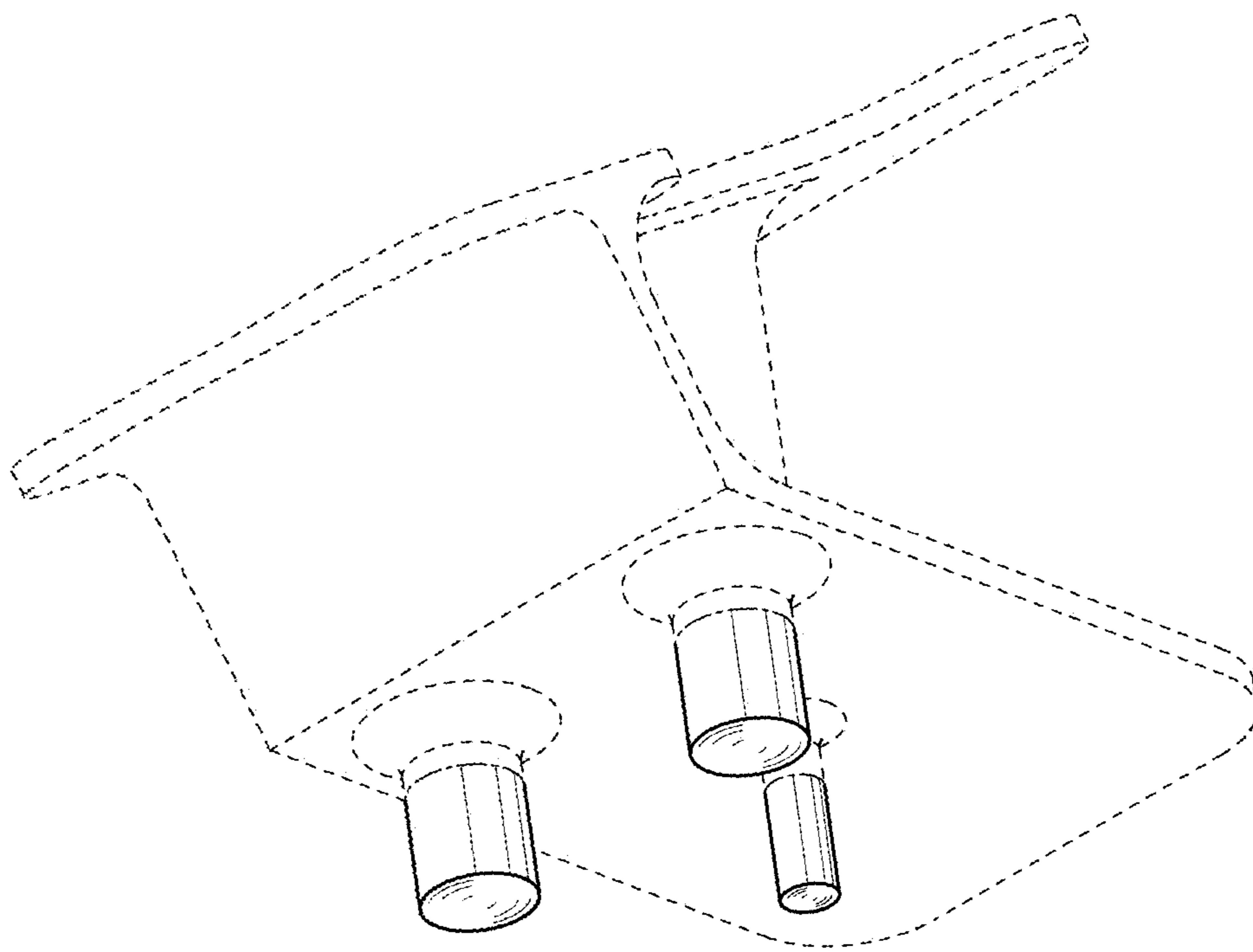

FIG. 5

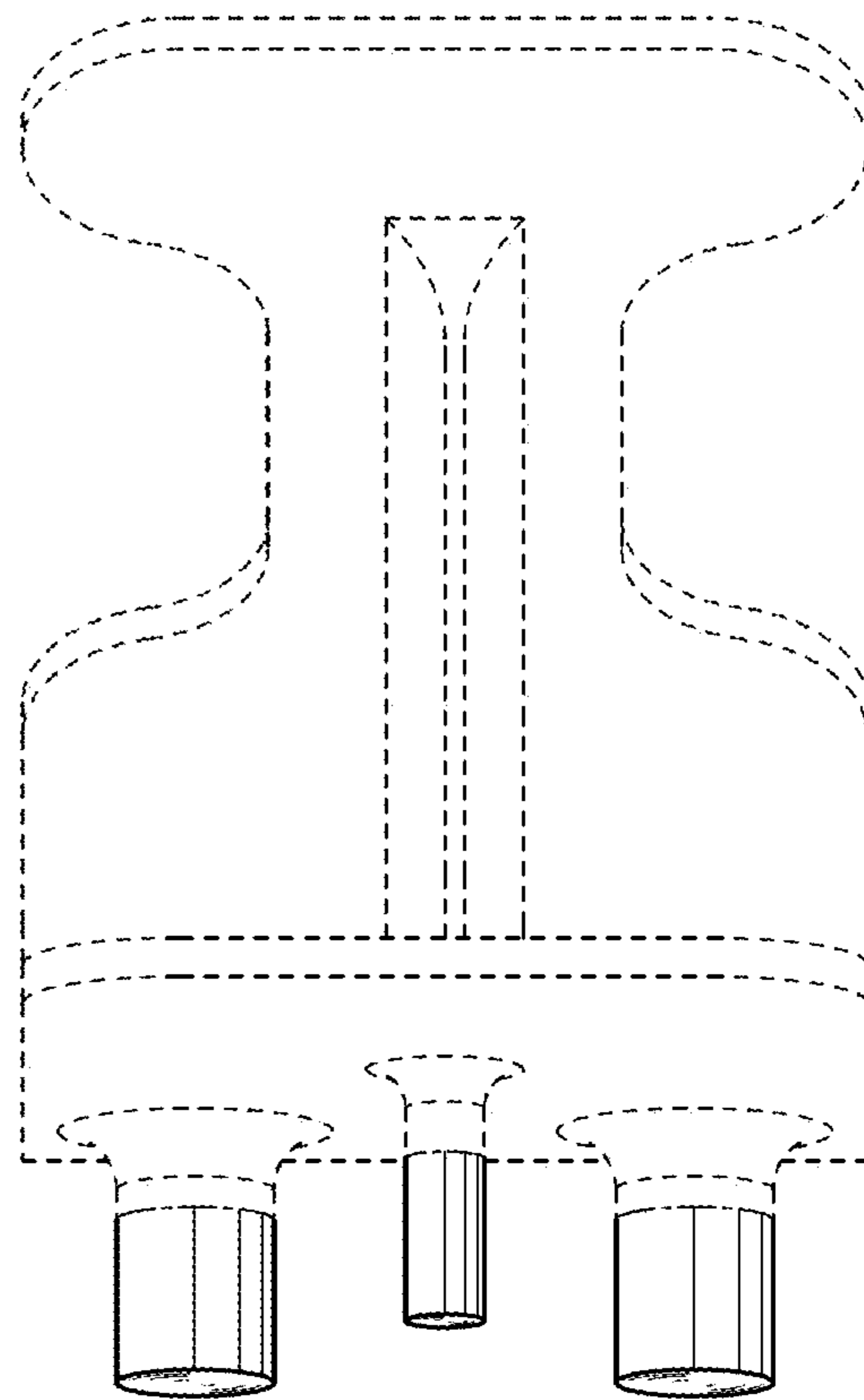

FIG. 6

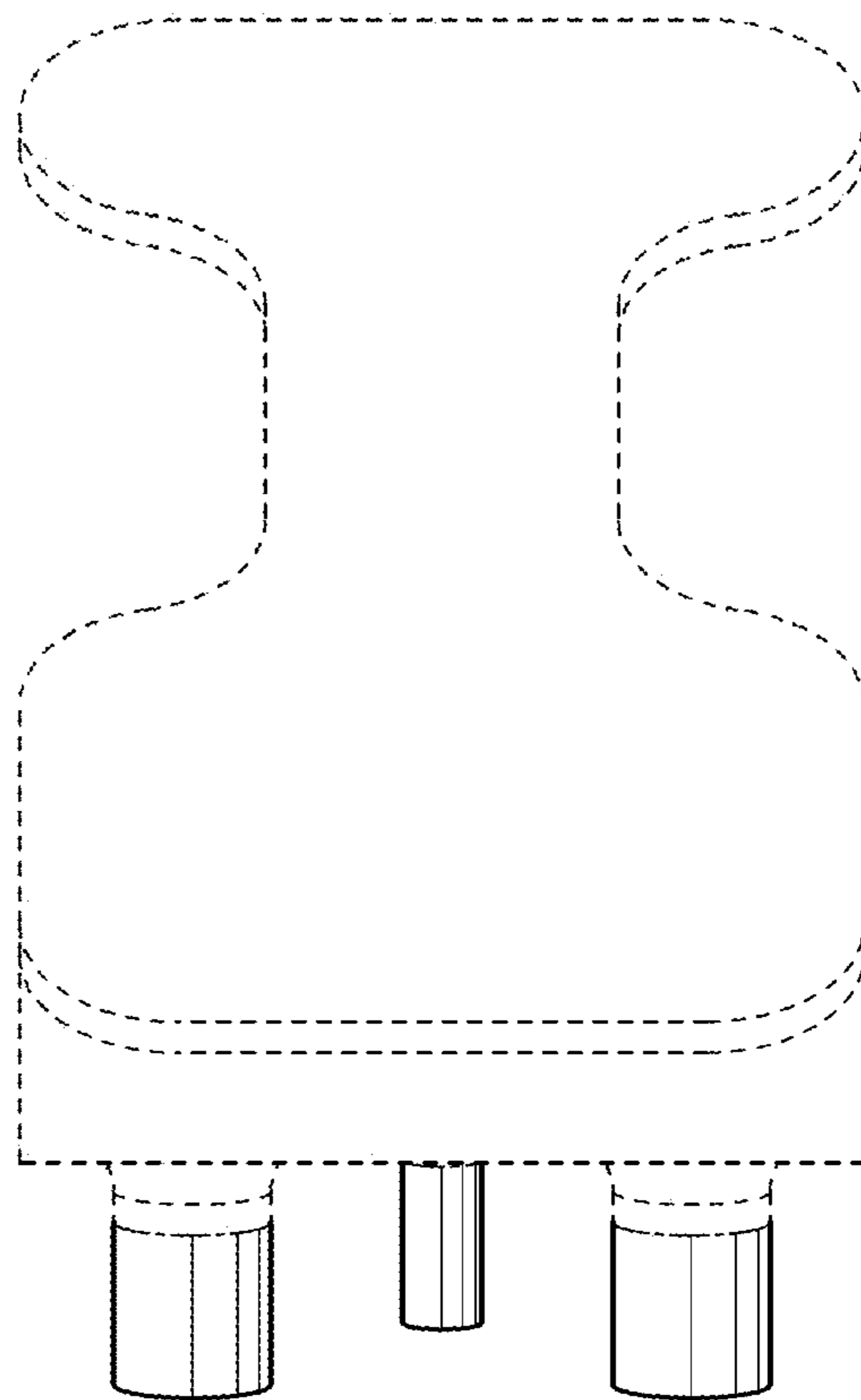

FIG. 7

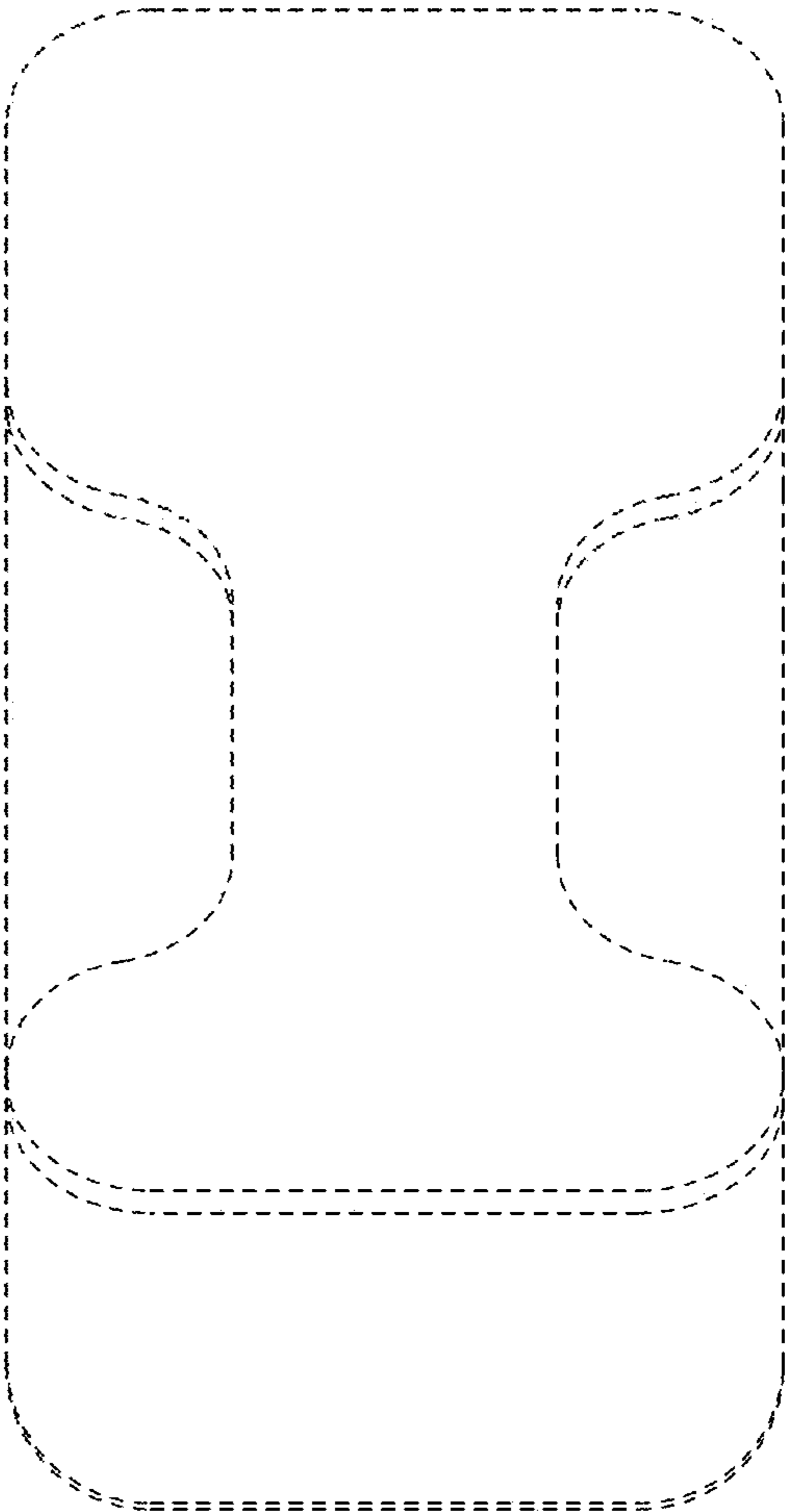

FIG. 8

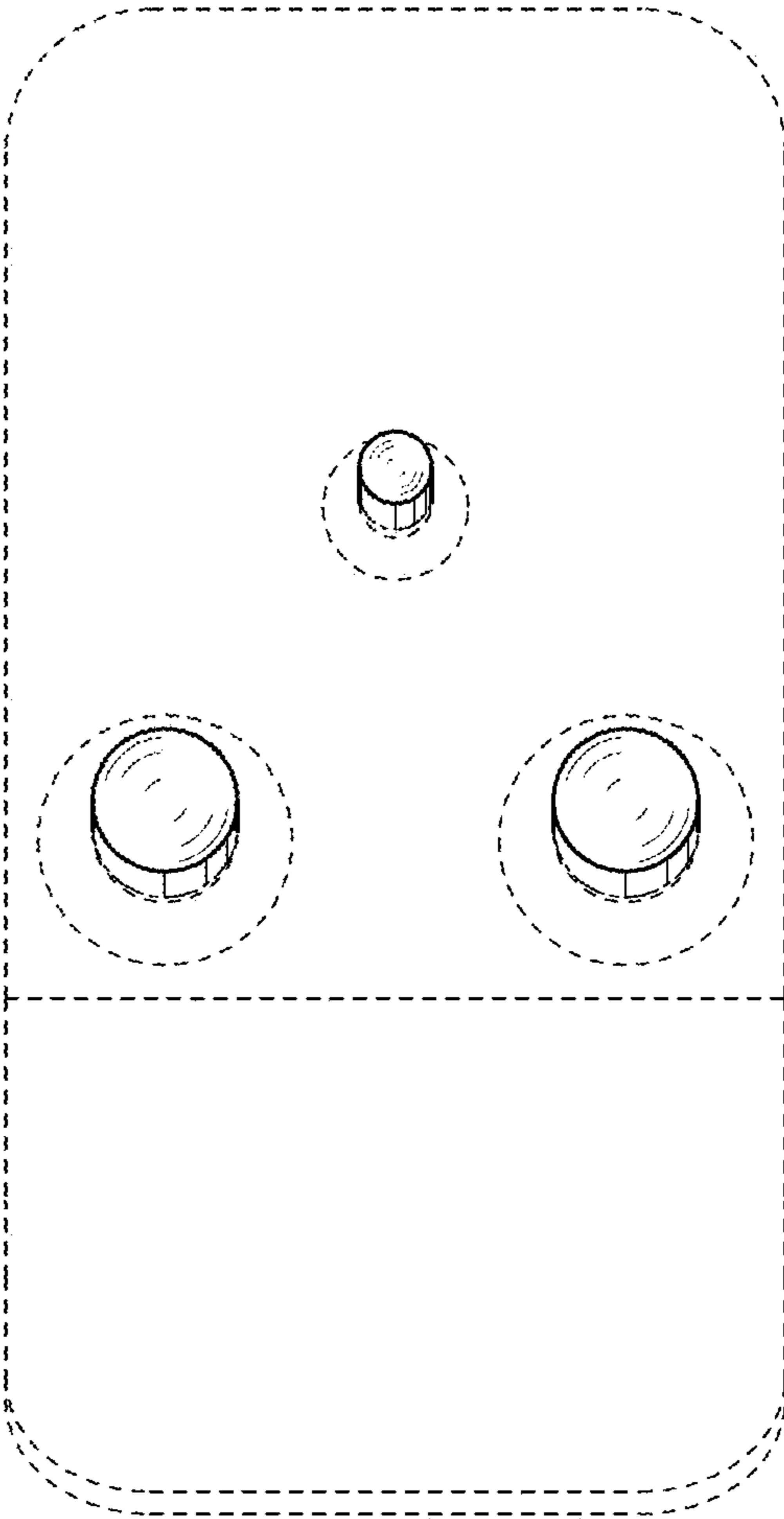

FIG. 9

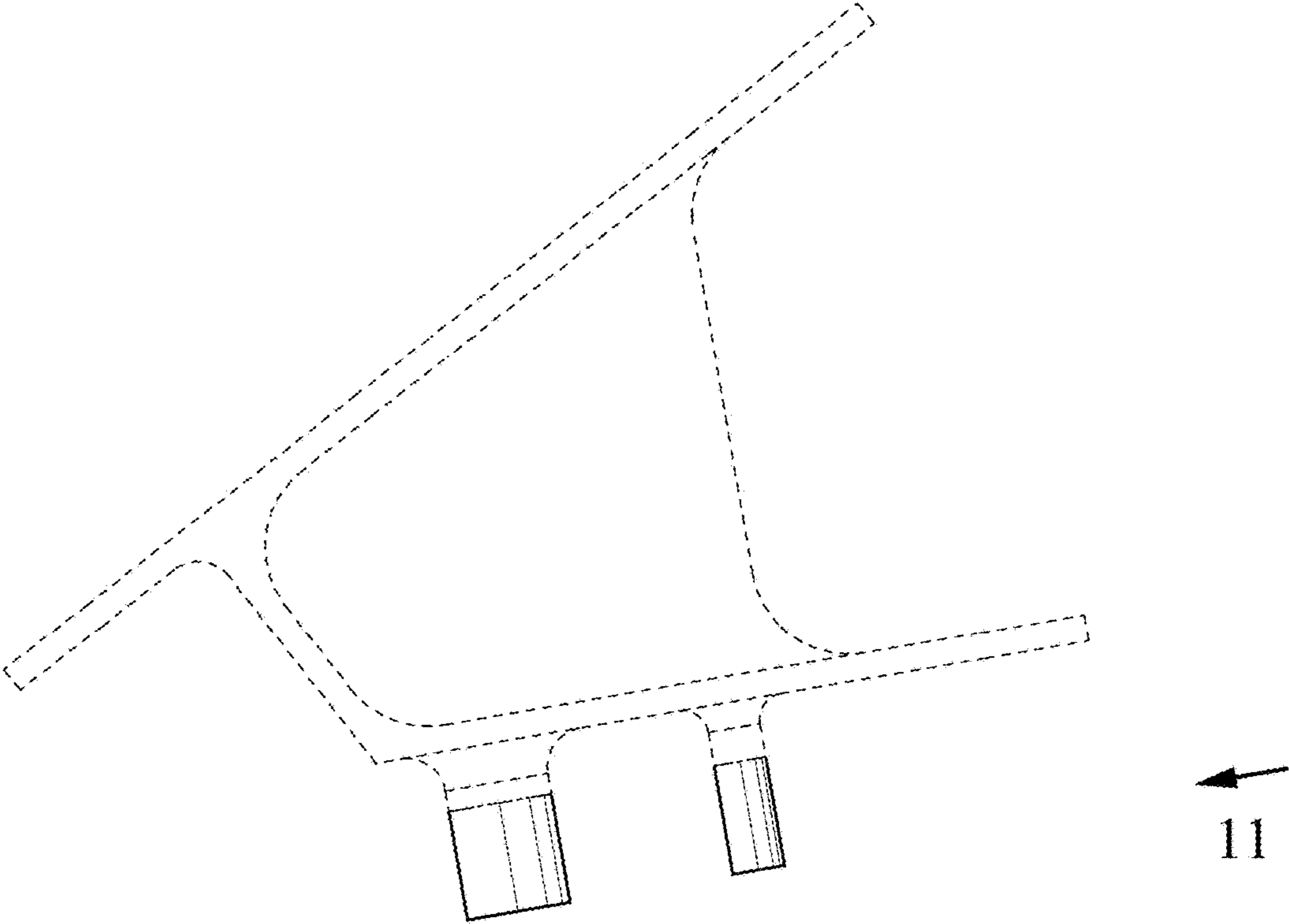

FIG. 10

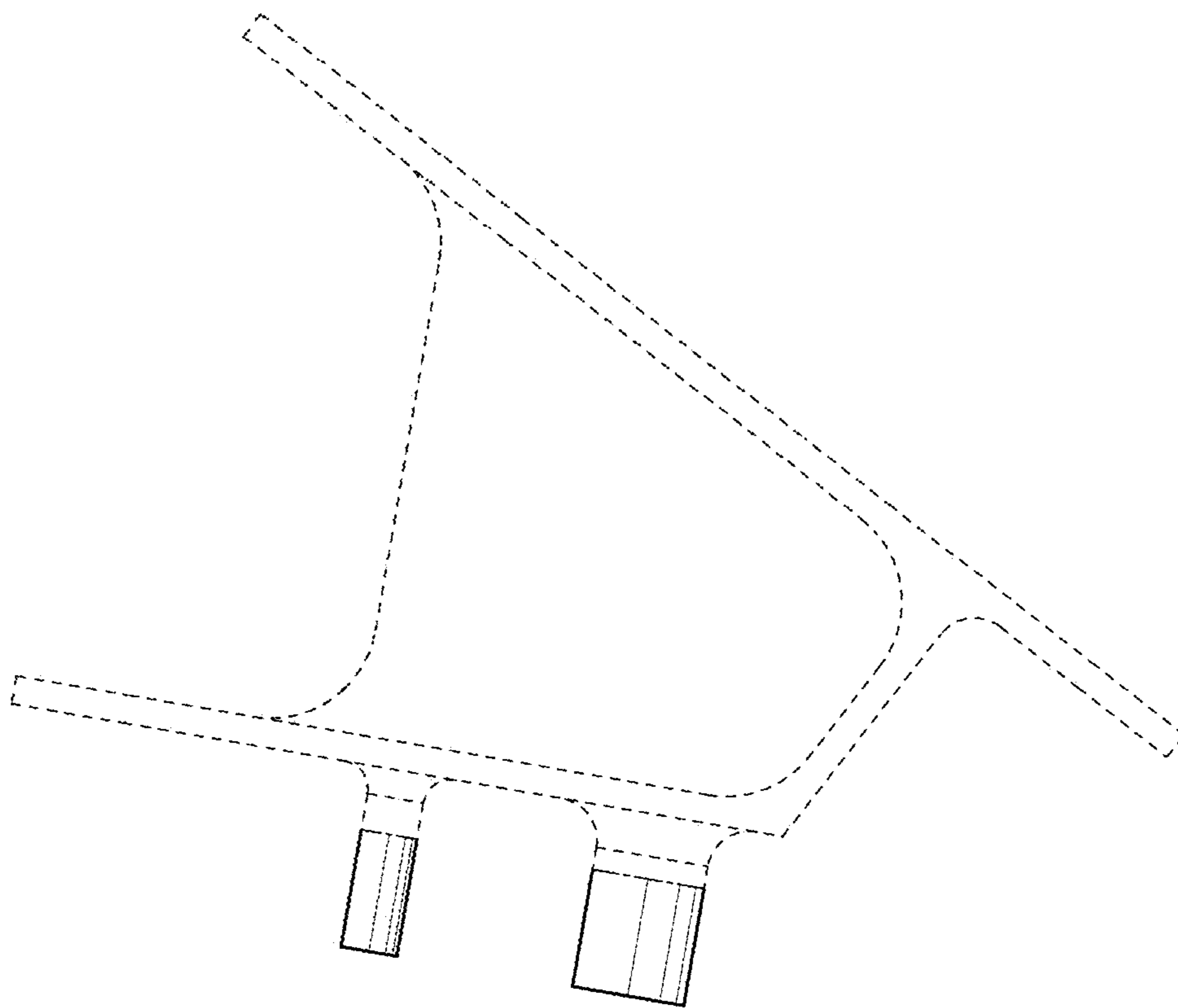

FIG. 11

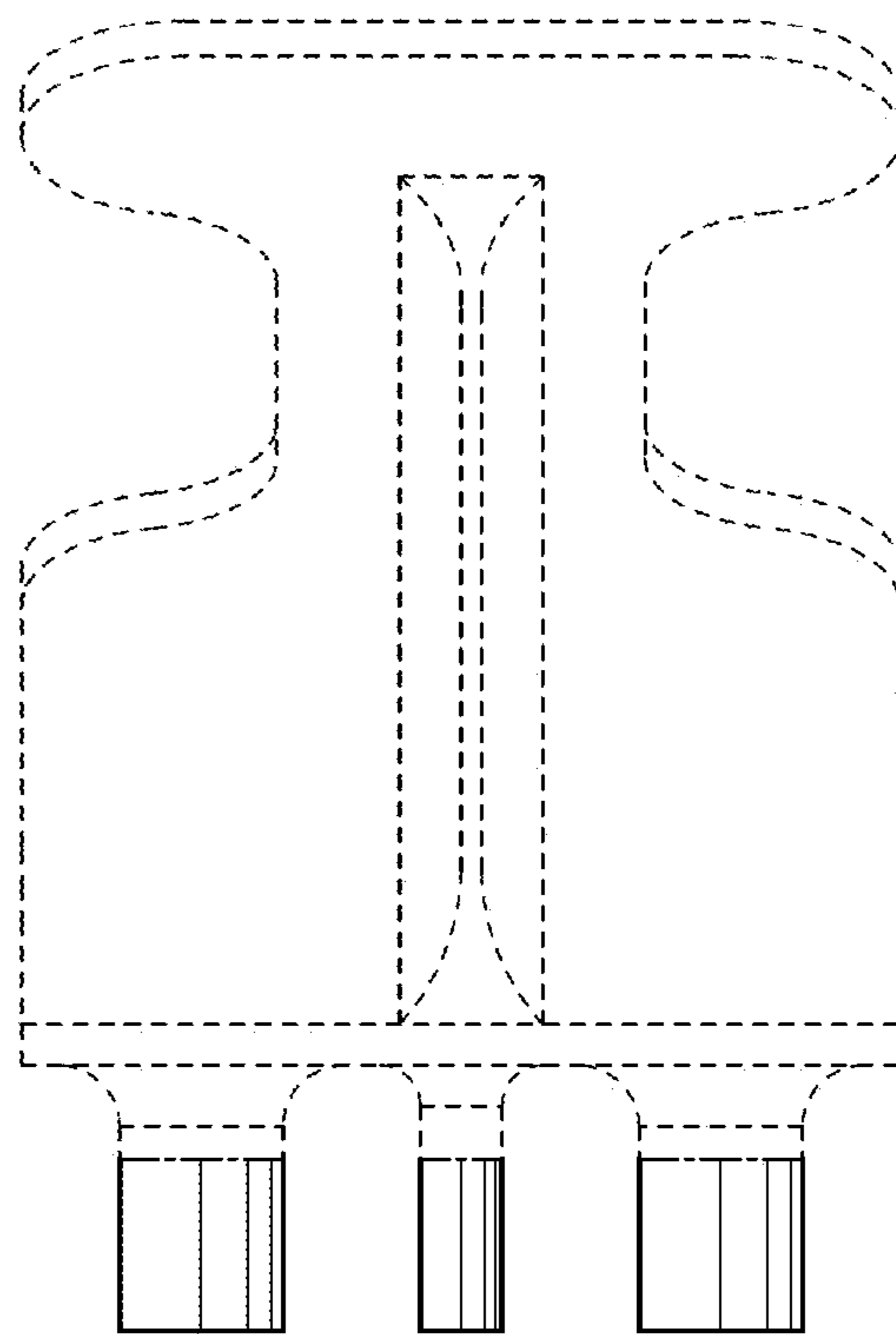

FIG. 12

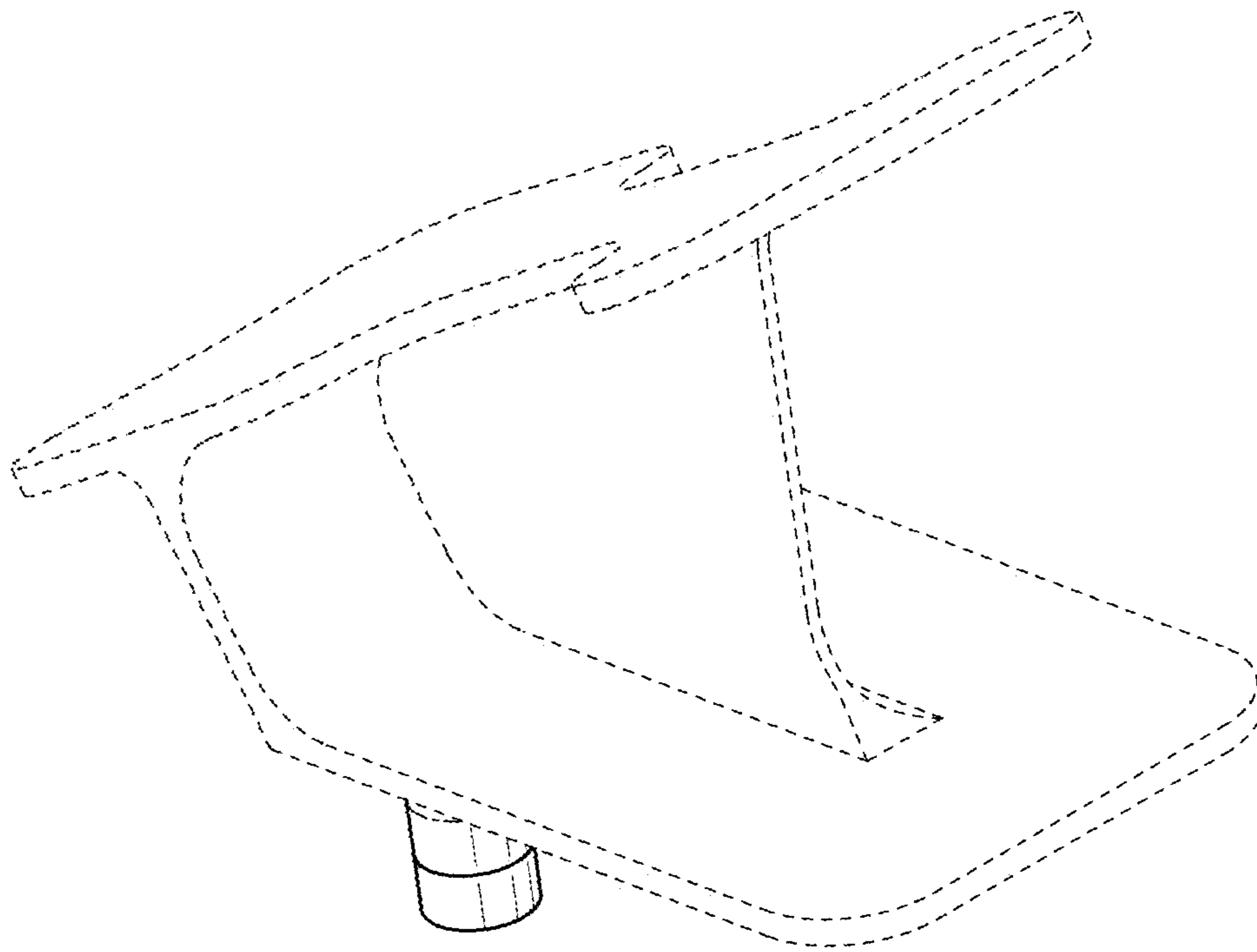

FIG. 13

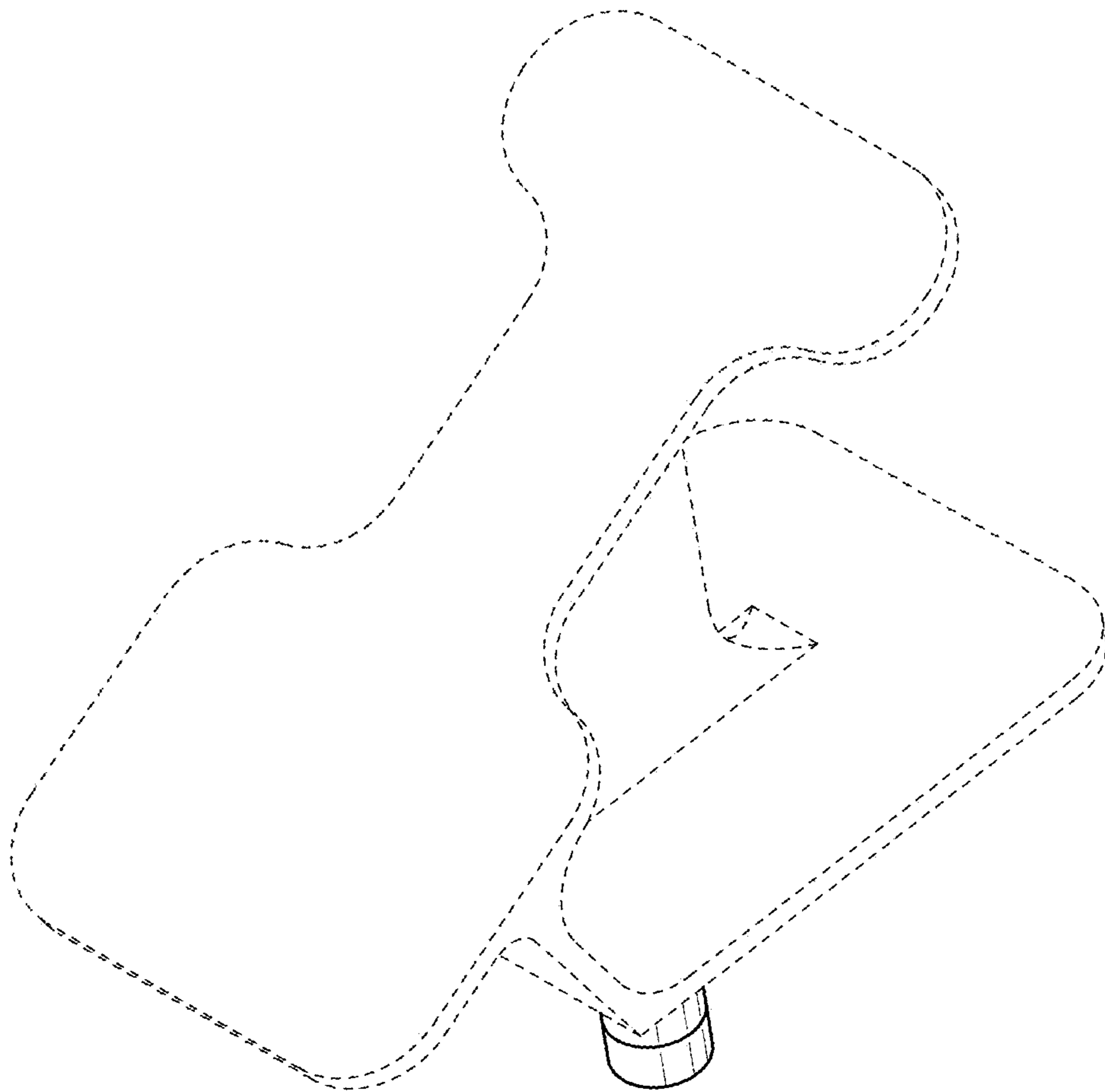

FIG. 14

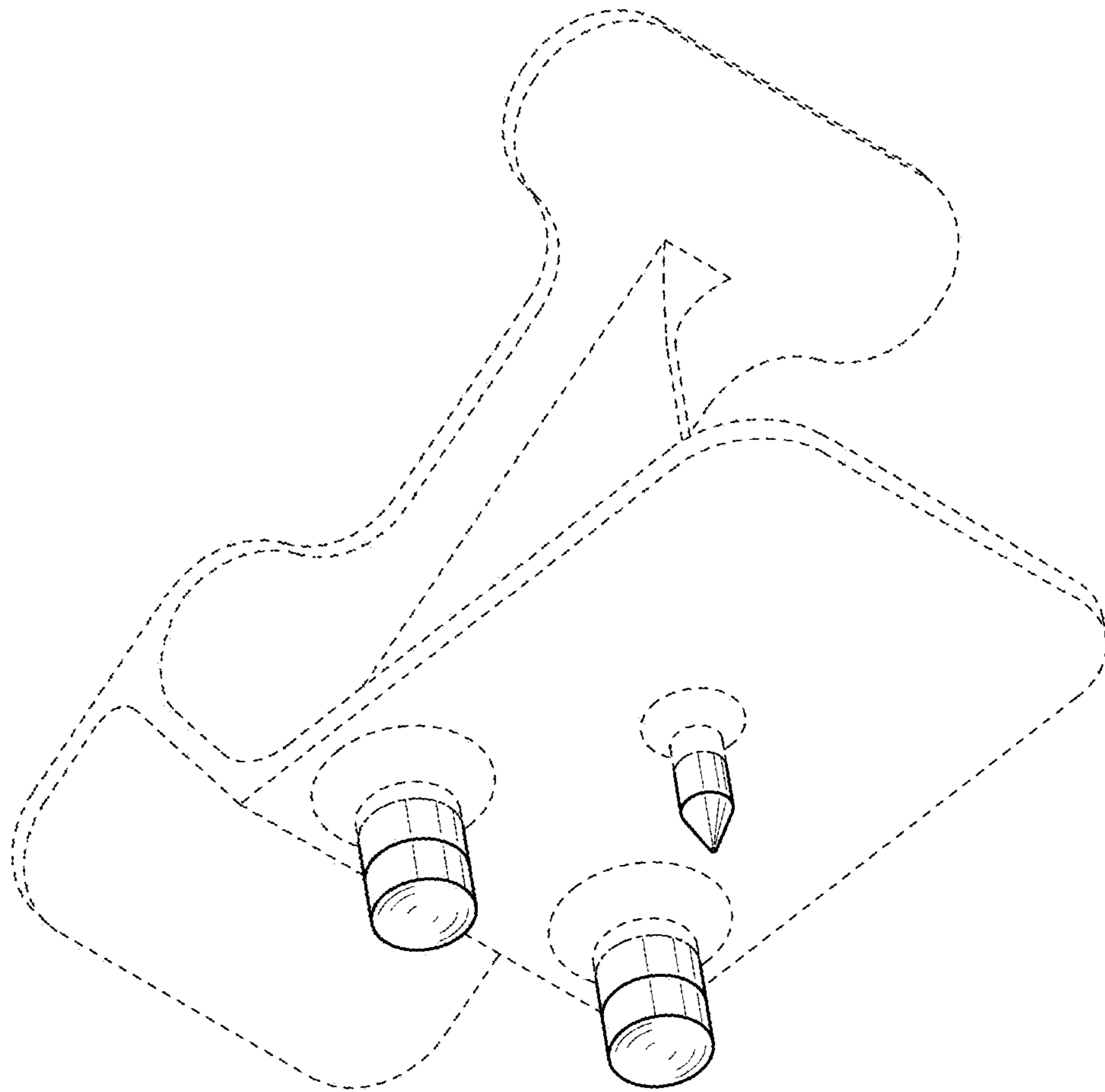

FIG. 15

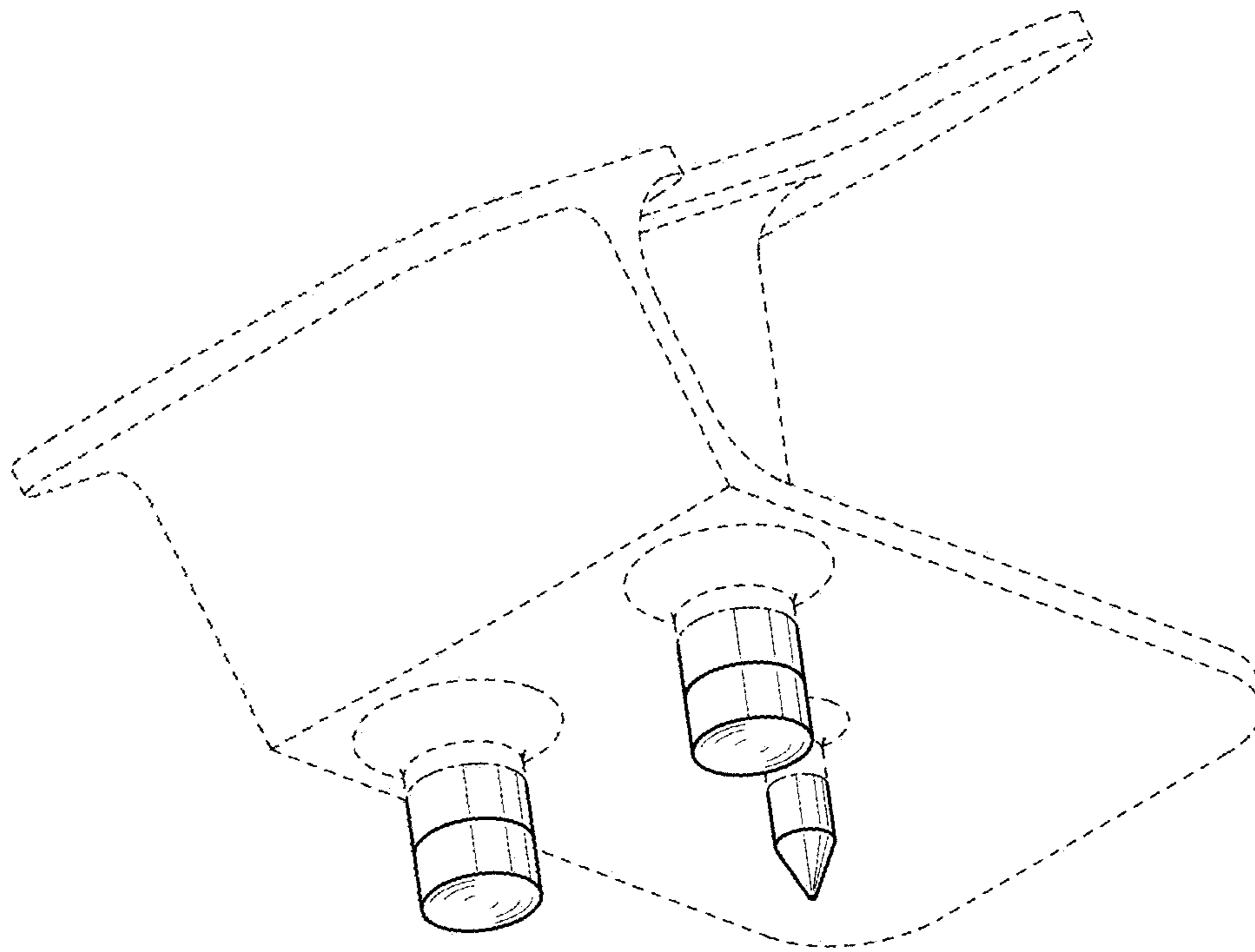

FIG. 16

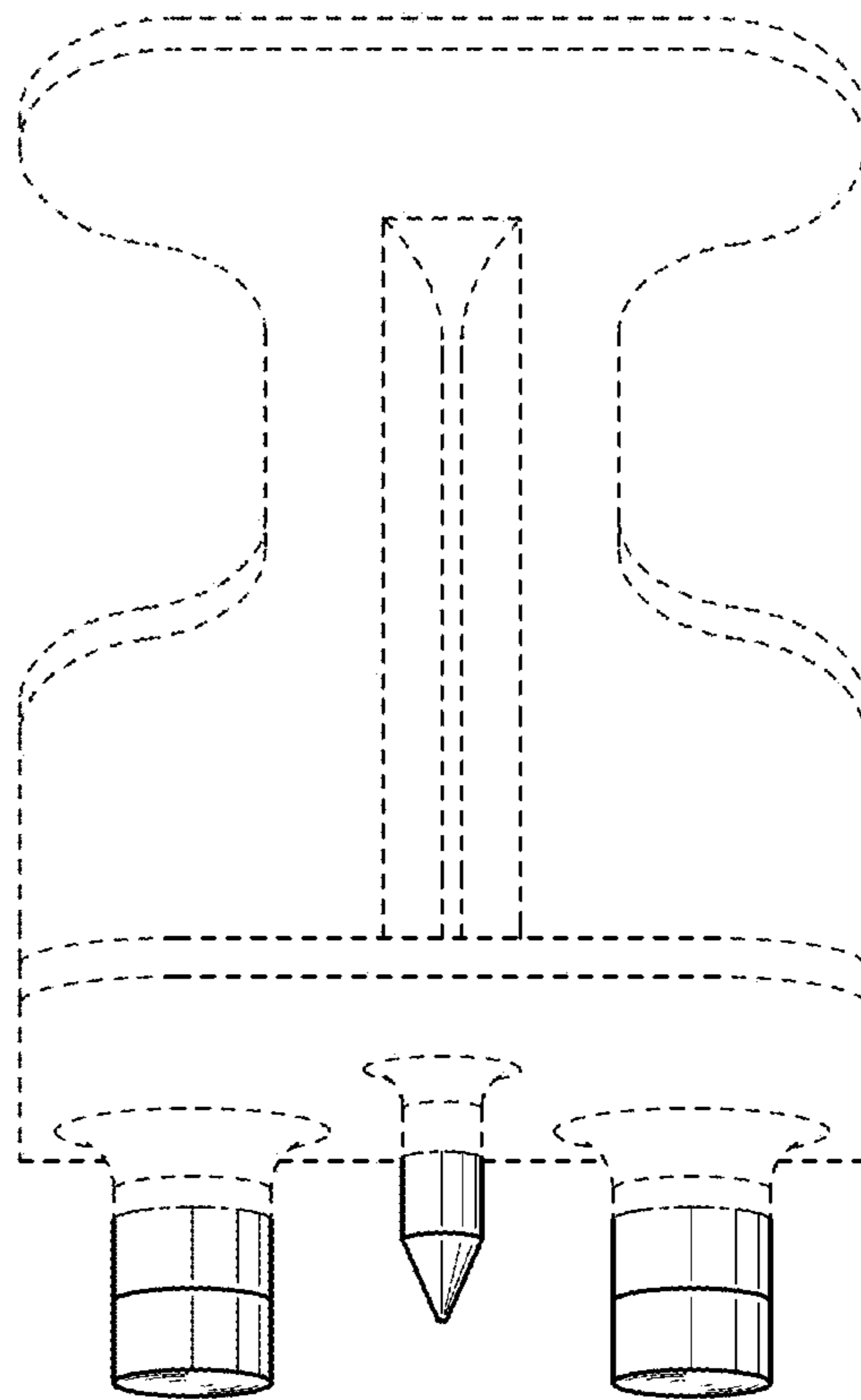

FIG. 17

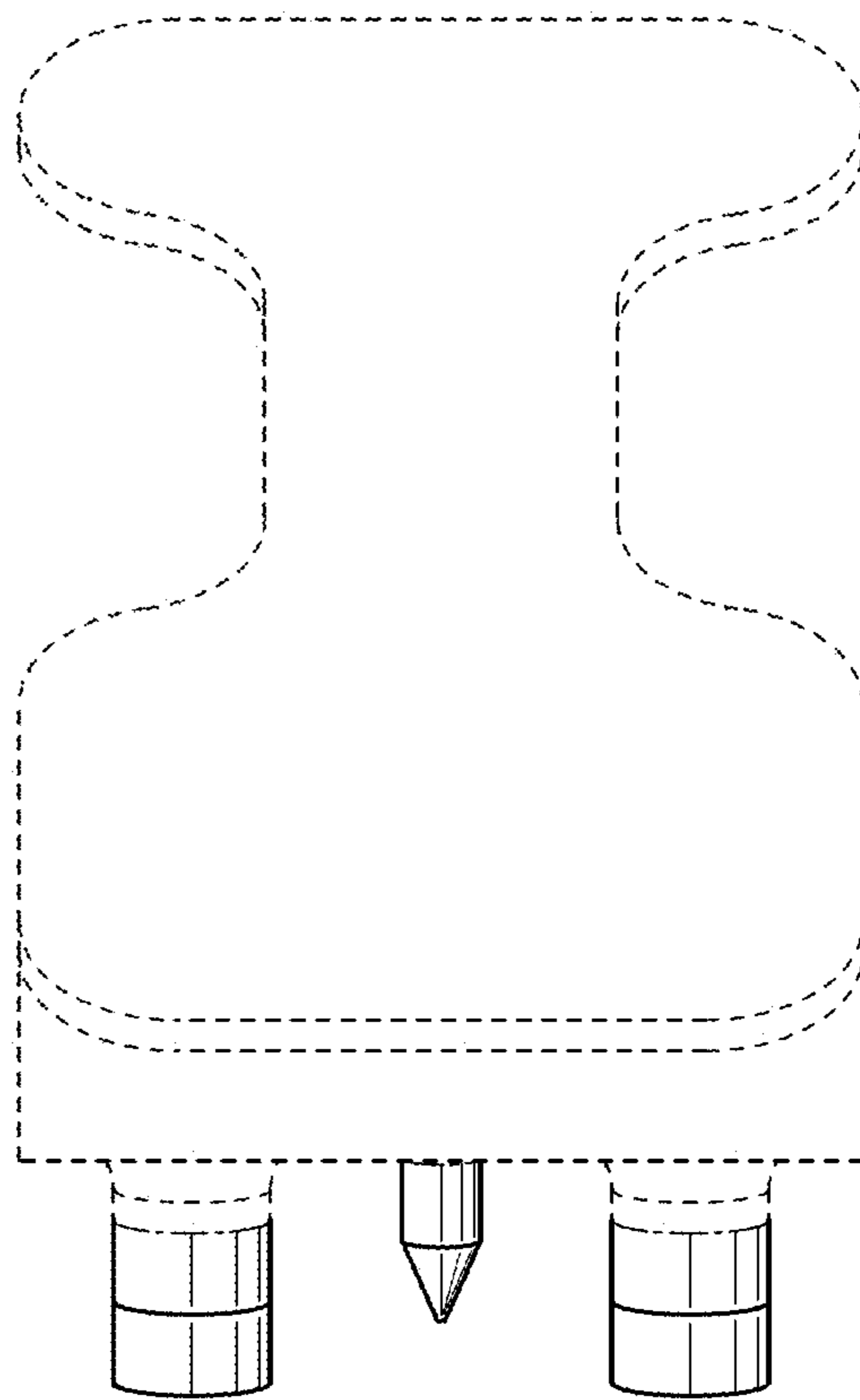

FIG. 18

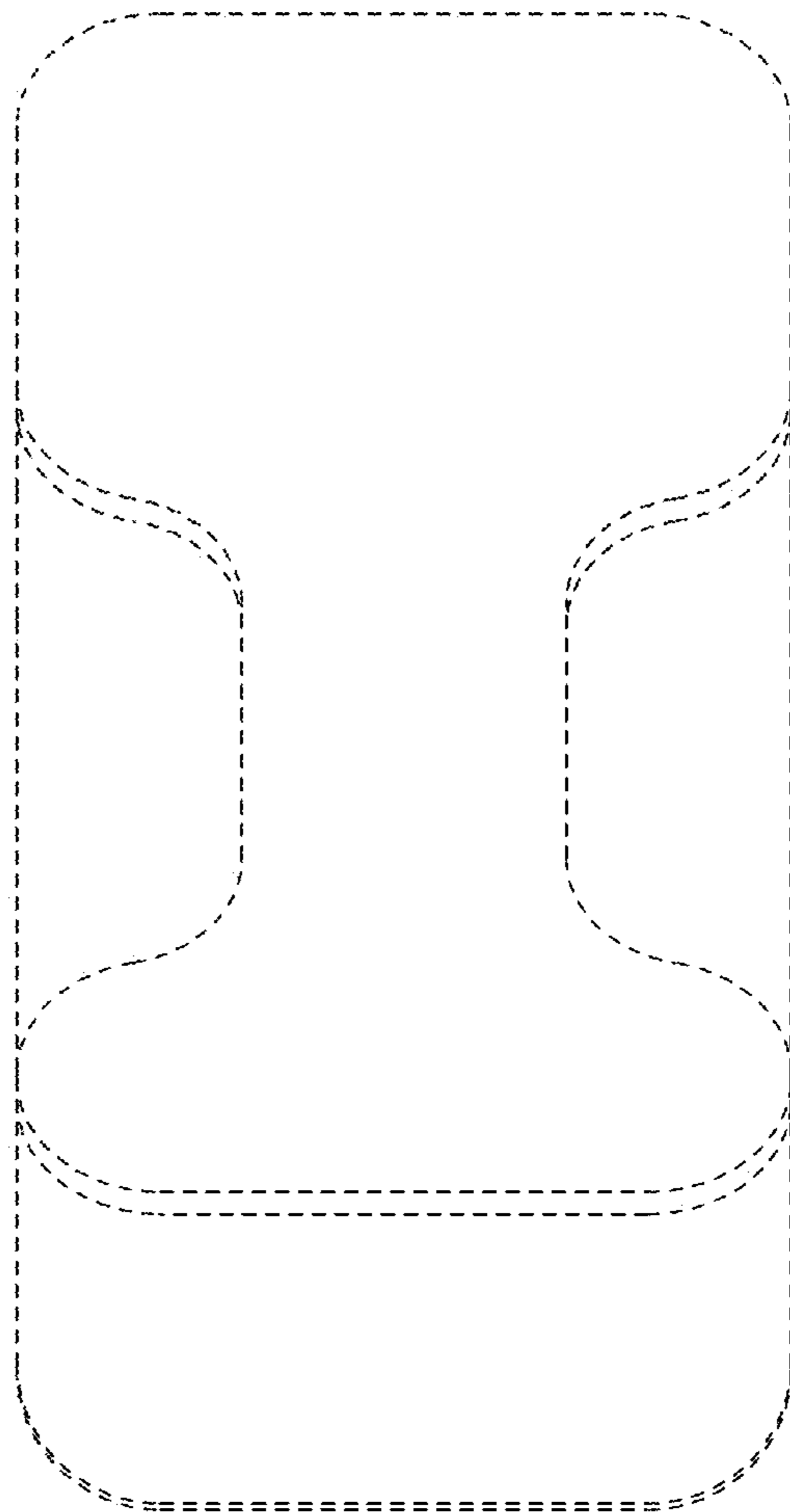

FIG. 19

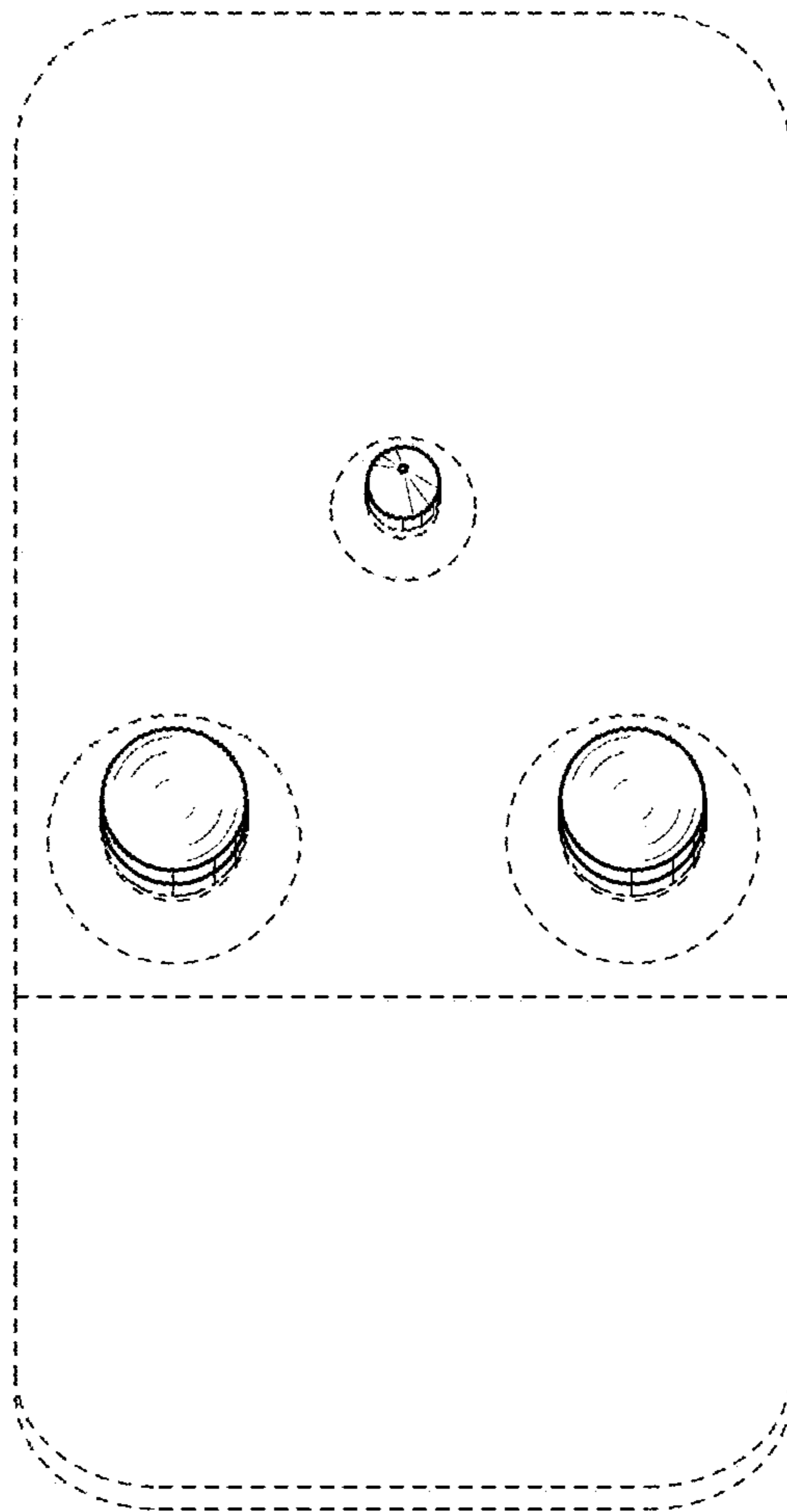

FIG. 20

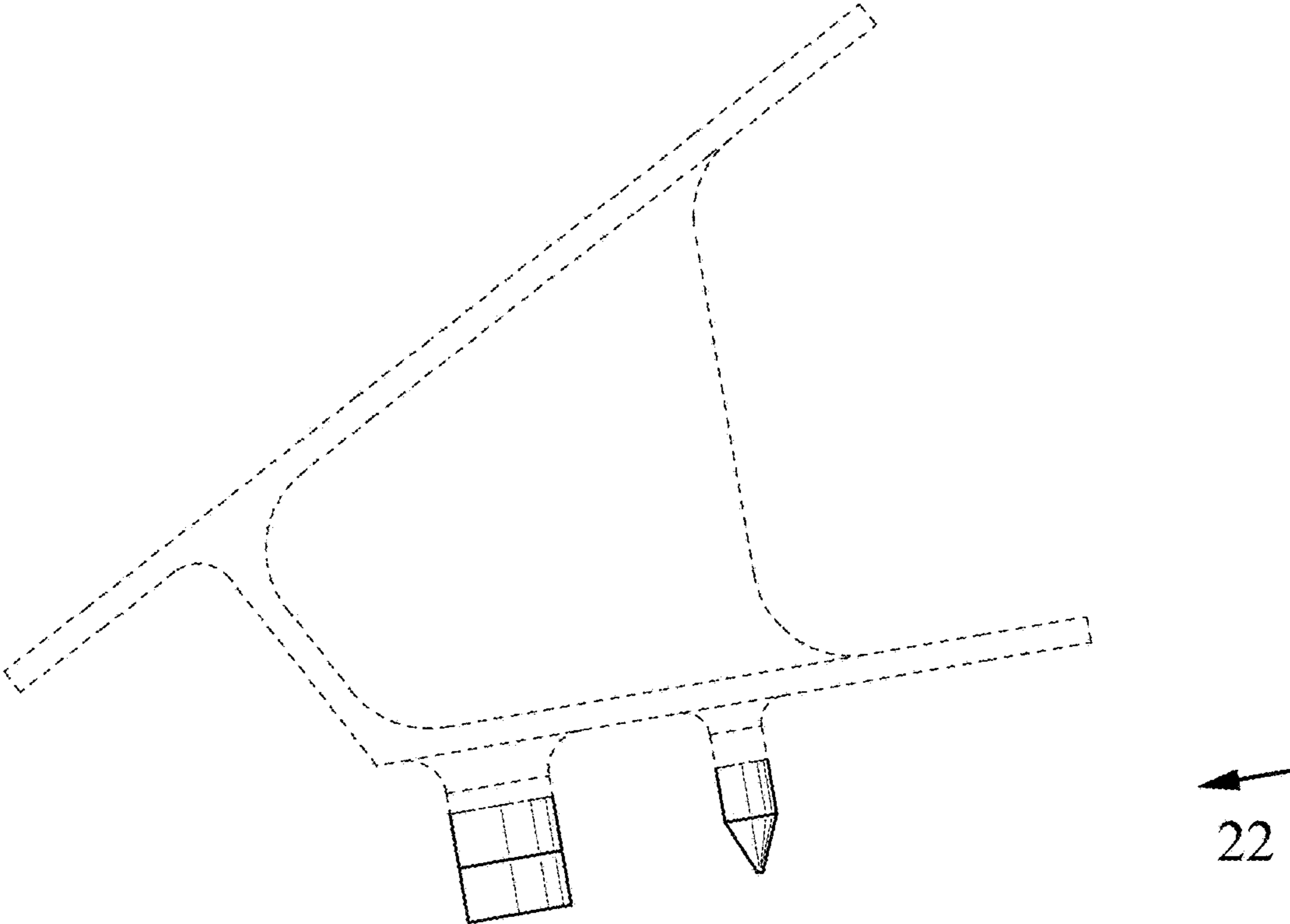

FIG. 21

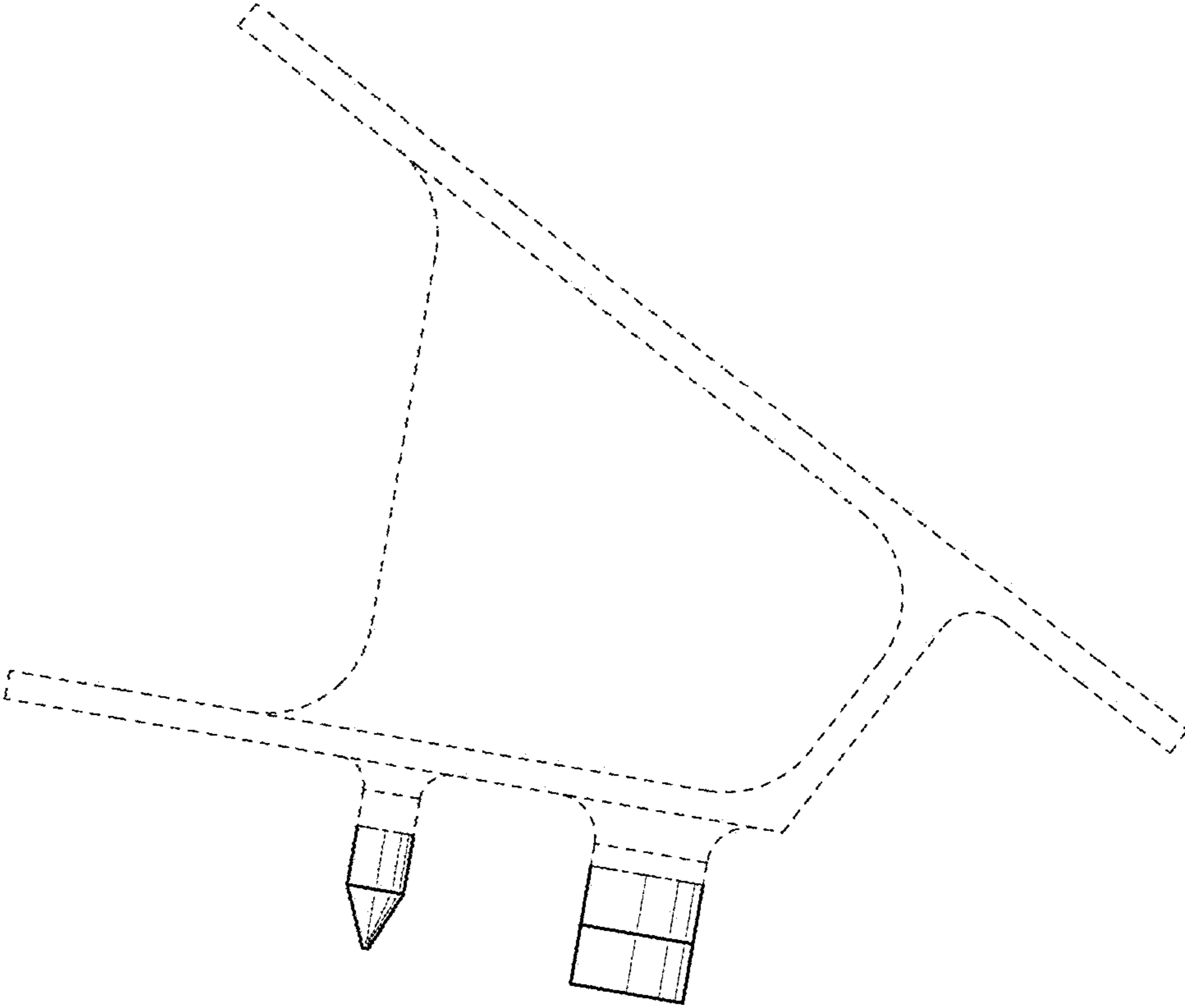

FIG. 22

