



US00D833890S

(12) **United States Design Patent** (10) **Patent No.:** **US D833,890 S**
Rook et al. (45) **Date of Patent:** **** Nov. 20, 2018**

(54) **CLOCK**

FOREIGN PATENT DOCUMENTS

(71) Applicant: **Bentley Motors Limited**, Cheshire (GB)

CH 339575 A * 6/1959 G04B 19/10
CH 706636 A2 * 12/2013 G04B 45/0084

(72) Inventors: **David Alan Rook**, Cheshire (GB);
Richard Hartley, Nottingham (GB);
Darren Day, Cheshire (GB); **George Bowen**, Cheshire (GB)

OTHER PUBLICATIONS

D'Marge, Bentley Bentayga Tourbillon clock costs \$170,000, posted on Sep. 20, 2015, [online], [site visited on Mar. 16, 2017]. Available from Internet, <URL: <https://www.dmarge.com/2015/09/bentley-bentayga-breitling-tourbillon.html>>.*

(73) Assignee: **Fritz Hansen A/S**, Allerod (DK)

(Continued)

(**) Term: **15 Years**

Primary Examiner — Sheryl Lane

(21) Appl. No.: **29/556,962**

Assistant Examiner — Samantha N Wood

(22) Filed: **Mar. 4, 2016**

(74) *Attorney, Agent, or Firm* — Renner, Otto, Boisselle & Sklar, LLP

(30) **Foreign Application Priority Data**

Sep. 9, 2015 (EM) 002769141-001
Sep. 9, 2015 (EM) 002769141-002

(57) **CLAIM**

(51) **LOC (11) Cl.** **10-01**

The ornamental design for a clock, as shown and described.

(52) **U.S. Cl.**

USPC **D10/22**

(58) **Field of Classification Search**

USPC D12/110, 114, 126, 186, 190, 192, 195,
D12/415, 422, 425; D10/1, 17, 20, 21,
D10/22, 30, 44, 45, 111, 123, 126, 127,
D10/132, 103, 18, 2

DESCRIPTION

CPC G04B 19/10; G04B 27/001; G04B 33/10;
G04B 37/144; G04B 45/00; G04B 45/0046; G04B 45/0069; G04B 45/0076;
G04B 47/00; G04B 47/001; B60Q 3/12;
B60Q 3/14; B60Q 3/16; B60Q 3/18;
B60Q 3/30; B60Q 3/57; B60Q 2500/10

FIG. 1 is a top, front, right perspective view of a clock showing our new design;
FIG. 2 is a top, rear, right perspective view thereof;
FIG. 3 is a top, front perspective view thereof;
FIG. 4 is a front elevation view thereof;
FIG. 5 is a right side elevation view thereof, a left side elevation view being a mirror image of the right side elevation view; and,
FIG. 6 is a top plan view thereof.

See application file for complete search history.

The broken lines shown in the drawings illustrate portions of the clock and form no part of the claimed design.

The phantom lines shown in FIG. 2 illustrate portions of the clock that are seen through a transparent, window portion of the clock housing and form no part of the claimed design.

(56) **References Cited**

U.S. PATENT DOCUMENTS

D45,160 S * 1/1914 Smith D10/101
D53,110 S * 3/1919 Bliss D10/1
D53,245 S * 4/1919 Hull D10/1

(Continued)

1 Claim, 6 Drawing Sheets

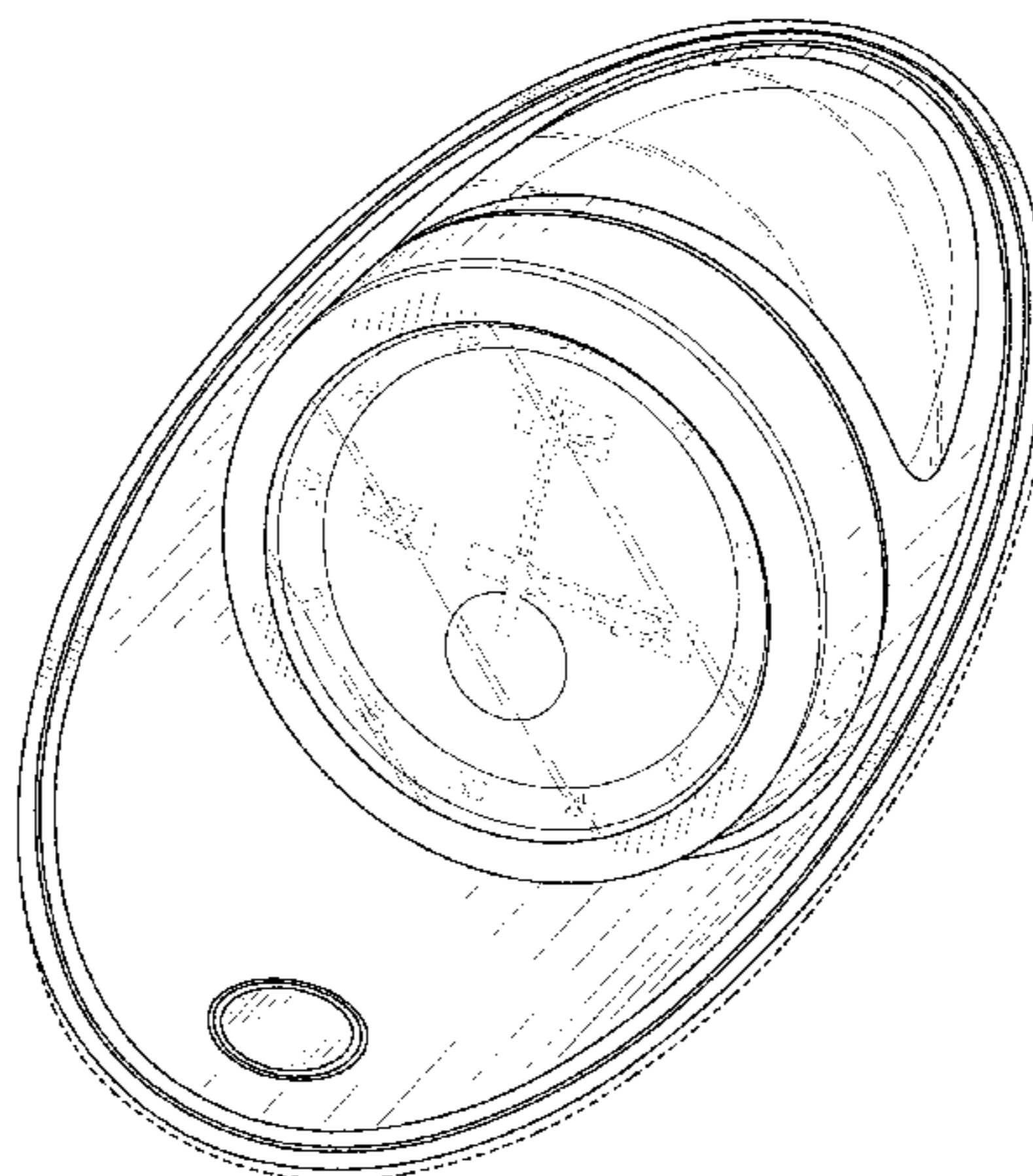

(56)

References Cited

U.S. PATENT DOCUMENTS

D55,520 S * 6/1920 Marsh D10/1
 D55,521 S * 6/1920 Marsh D10/1
 D56,099 S * 8/1920 Goodrow D10/1
 D56,422 S * 10/1920 Goodrow D10/1
 D56,425 S * 10/1920 Goodrow D10/1
 D56,426 S * 10/1920 Goodrow D10/1
 D66,077 S * 11/1924 Conant D10/1
 D71,672 S * 12/1926 Gruen D10/1
 1,634,447 A * 7/1927 Bowen G04B 37/04
 29/896.33
 D176,407 S * 12/1955 Fletcher D10/126
 D190,749 S * 6/1961 Marti D10/1
 D230,966 S * 3/1974 Hill D12/192
 D303,934 S * 10/1989 Iacovelli D10/2
 D375,477 S * 11/1996 Kulla D12/192
 D405,408 S * 2/1999 Yoshida D12/192
 D412,853 S * 8/1999 Kokkinis D10/1
 D436,898 S * 1/2001 Okada D12/114
 D475,930 S * 6/2003 Chang D10/1
 D489,661 S * 5/2004 McPeck D12/192

D511,693 S * 11/2005 Ma D10/23
 D529,422 S * 10/2006 Lindgren D12/192
 D580,791 S * 11/2008 Kuchler D10/15
 D582,326 S * 12/2008 Shimizu D12/192
 D600,569 S * 9/2009 Sadler D10/15
 D605,543 S * 12/2009 Juraschek D10/124
 D610,045 S * 2/2010 Lambri D12/110
 D651,928 S * 1/2012 Favre D10/126
 D670,205 S * 11/2012 Takakuwa D12/110
 D688,580 S * 8/2013 Delhotal D10/124
 D690,237 S * 9/2013 Carducci D12/110
 D701,134 S * 3/2014 Cerrato D10/126
 D716,702 S * 11/2014 Song D12/110

OTHER PUBLICATIONS

Watch-Insider, Blog Post, posted on Sep. 10, 2013, [online], [site visited on Mar. 16, 2017]. Available from Internet, <URL: <http://www.watch-insider.com/news/chinese-contributor-logan-showing-today-sea-gull-tourbillon-timepieces-discovered-hong-kong-watch-clock-fair/>>.*

* cited by examiner

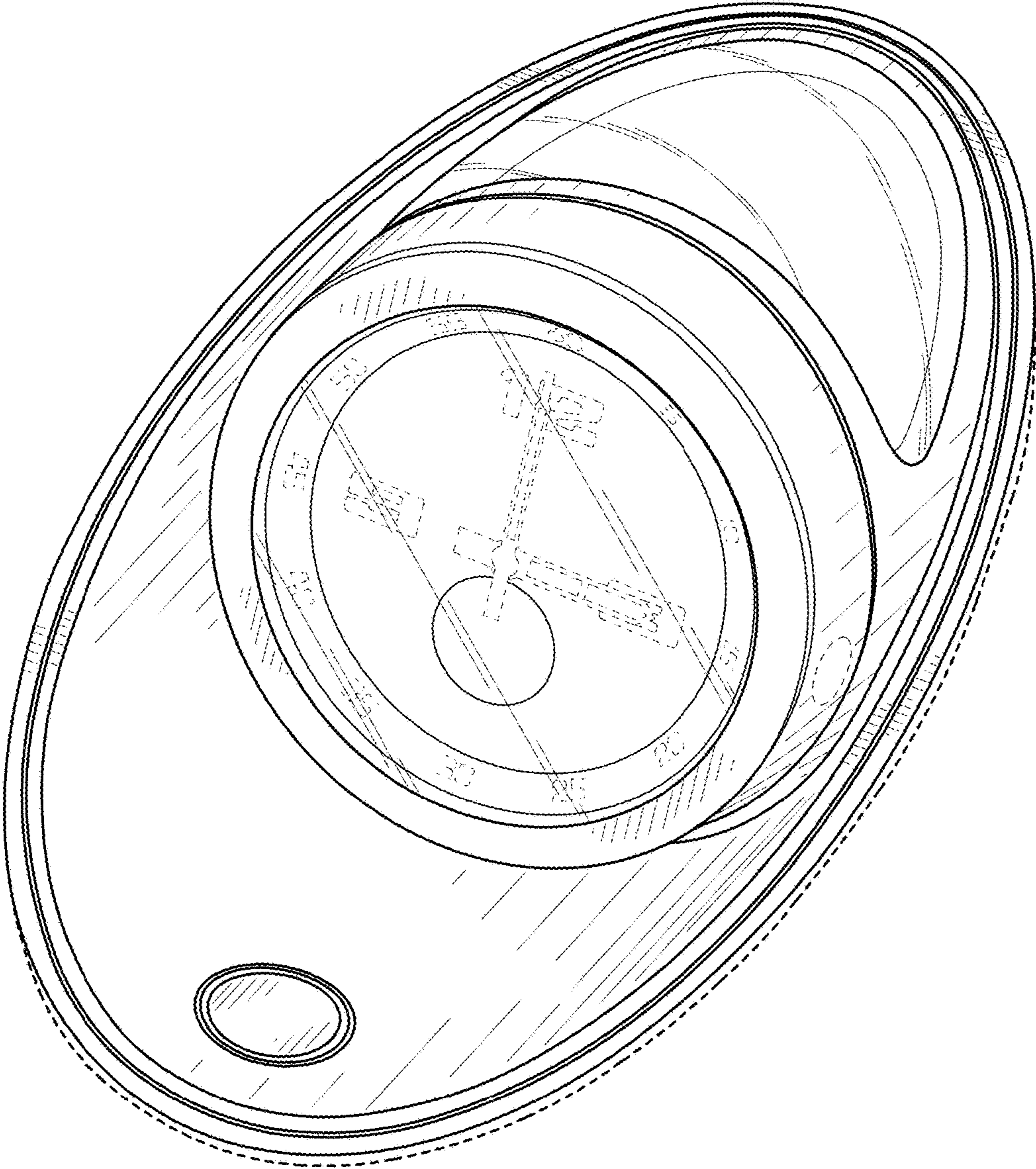

FIG. 1

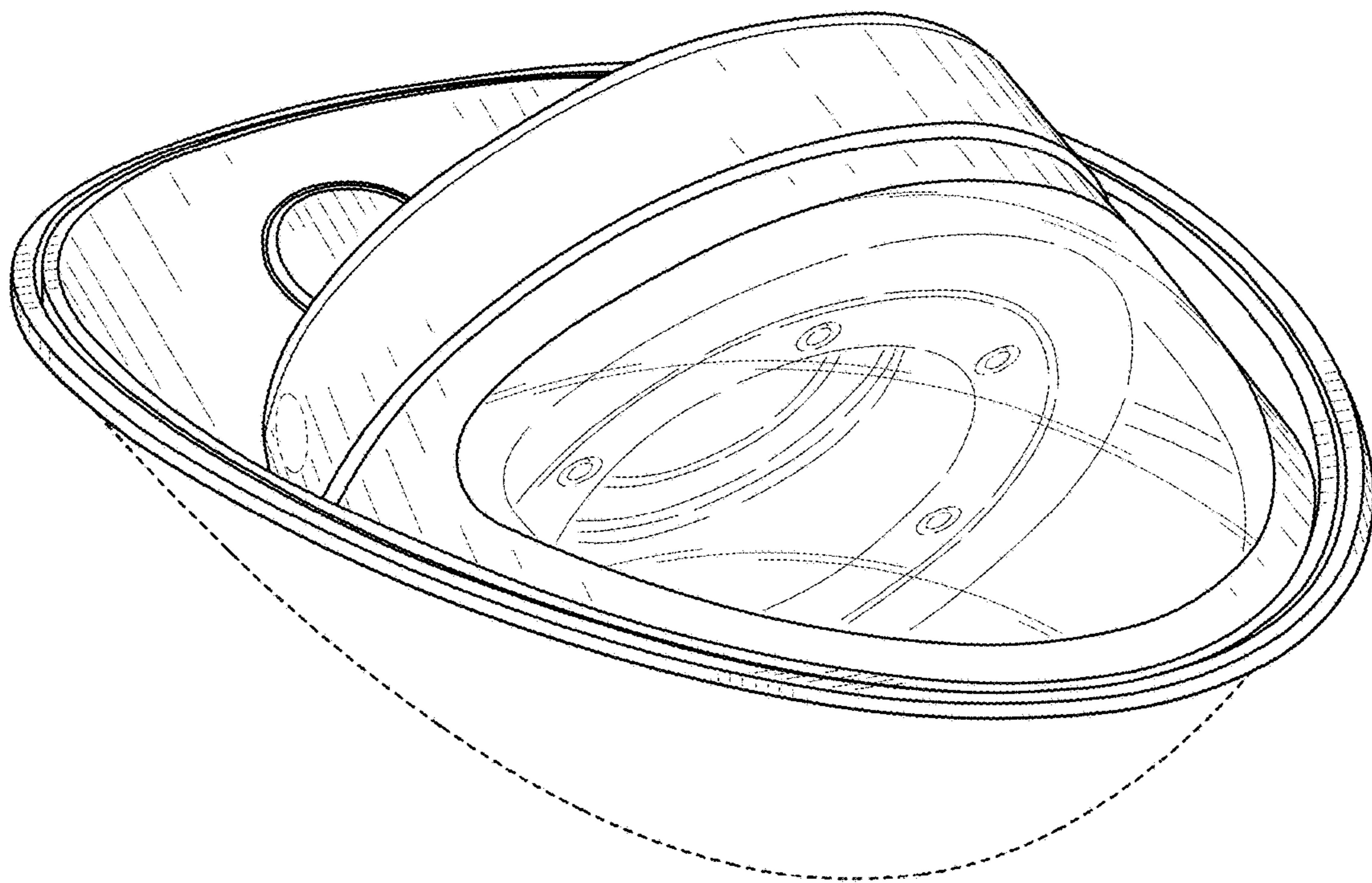

FIG. 2

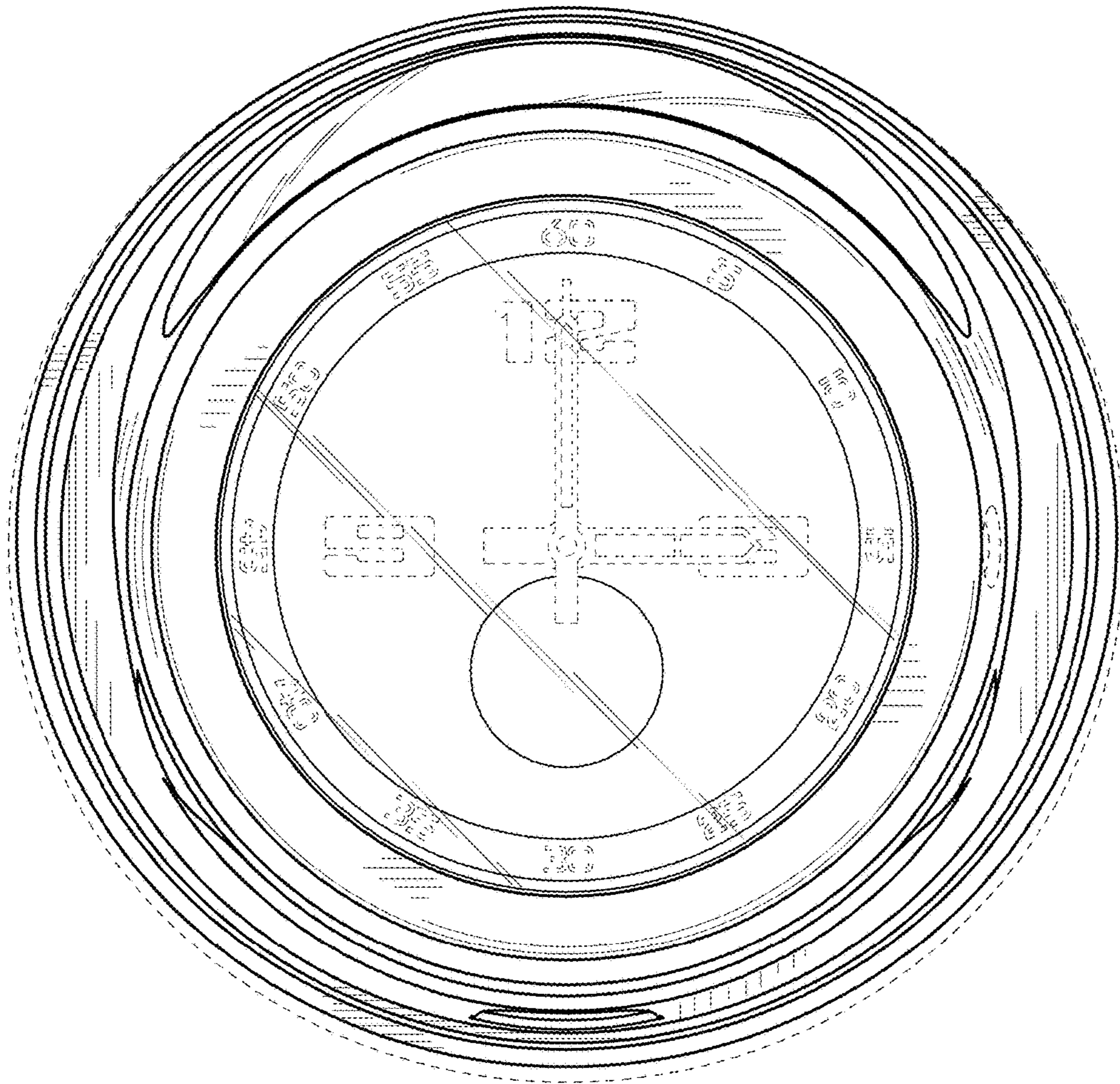

FIG. 3

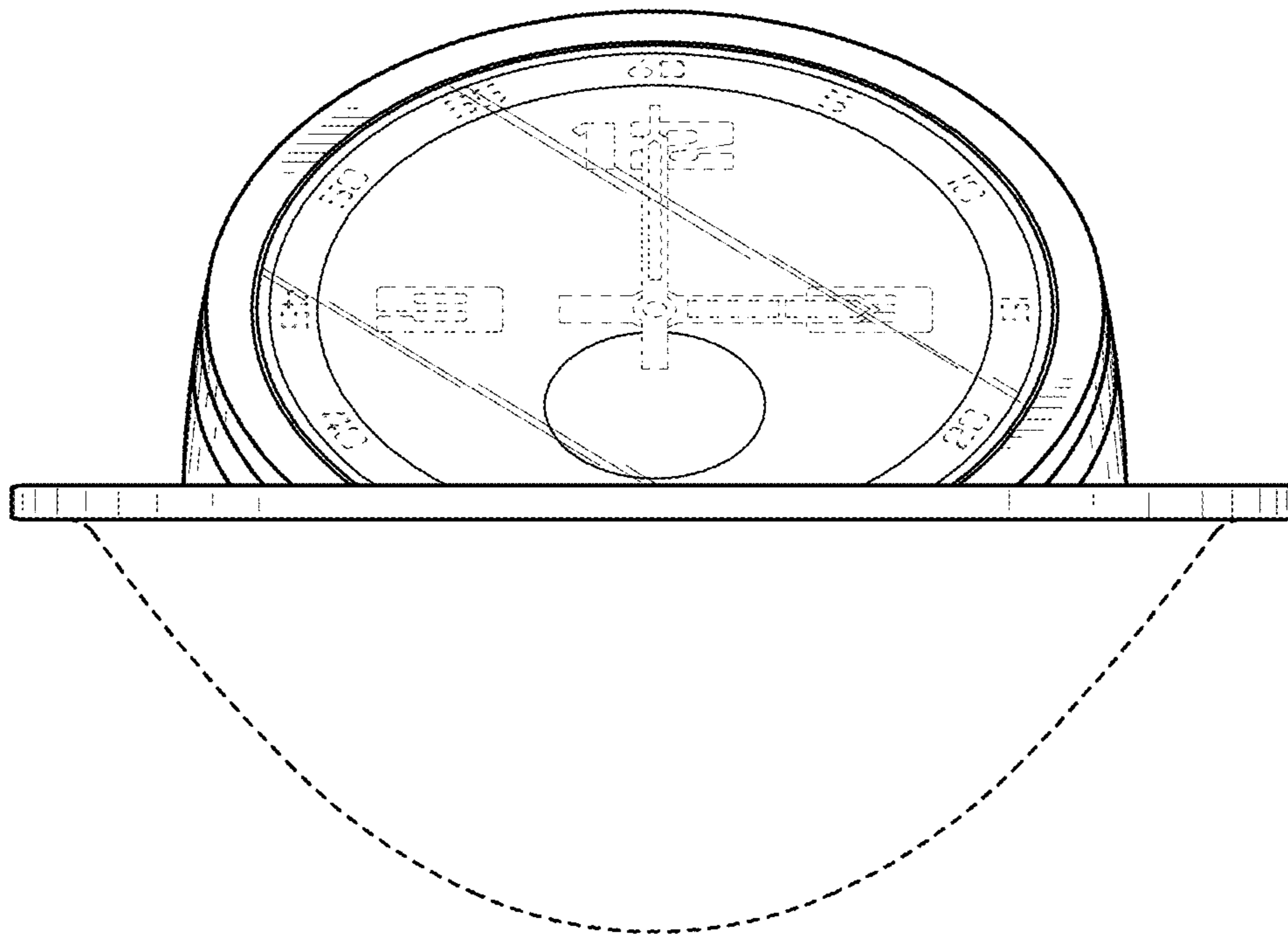

FIG. 4

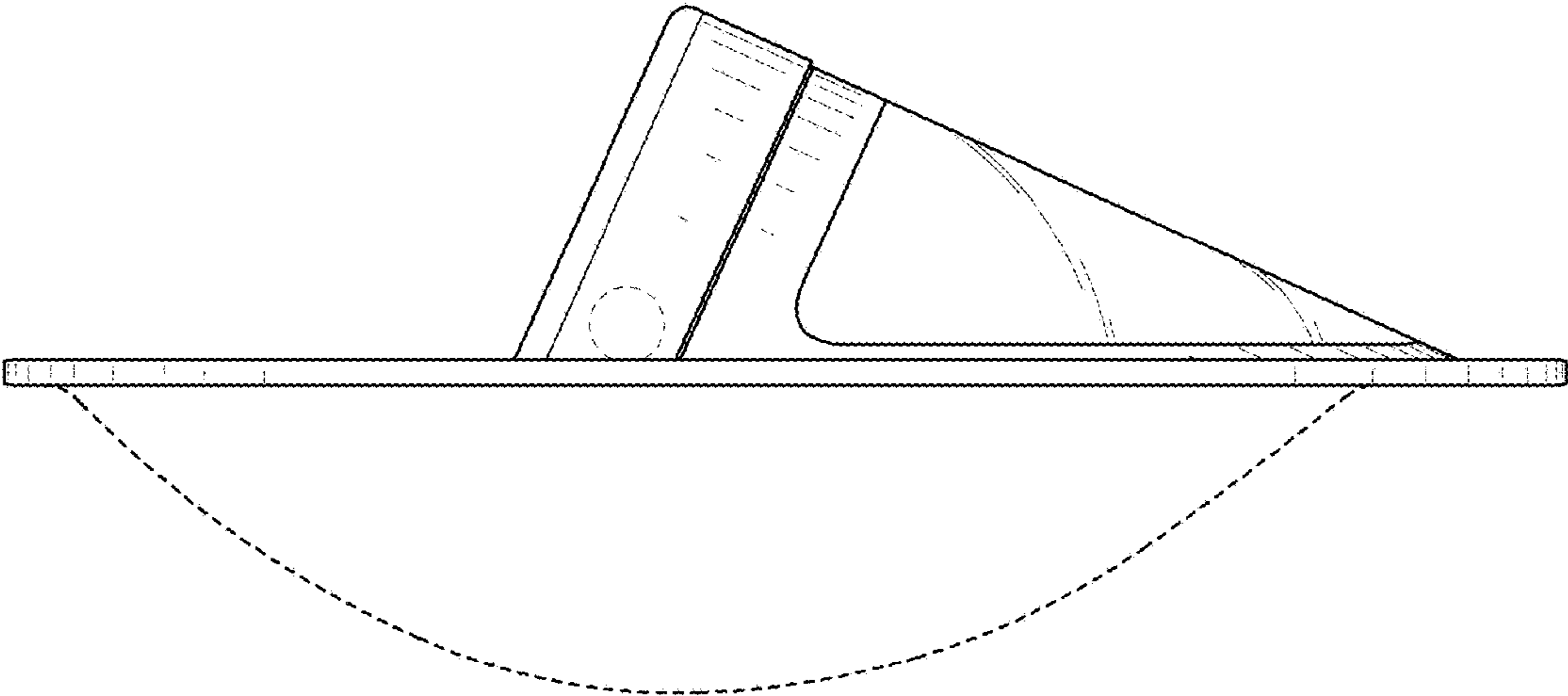

FIG. 5

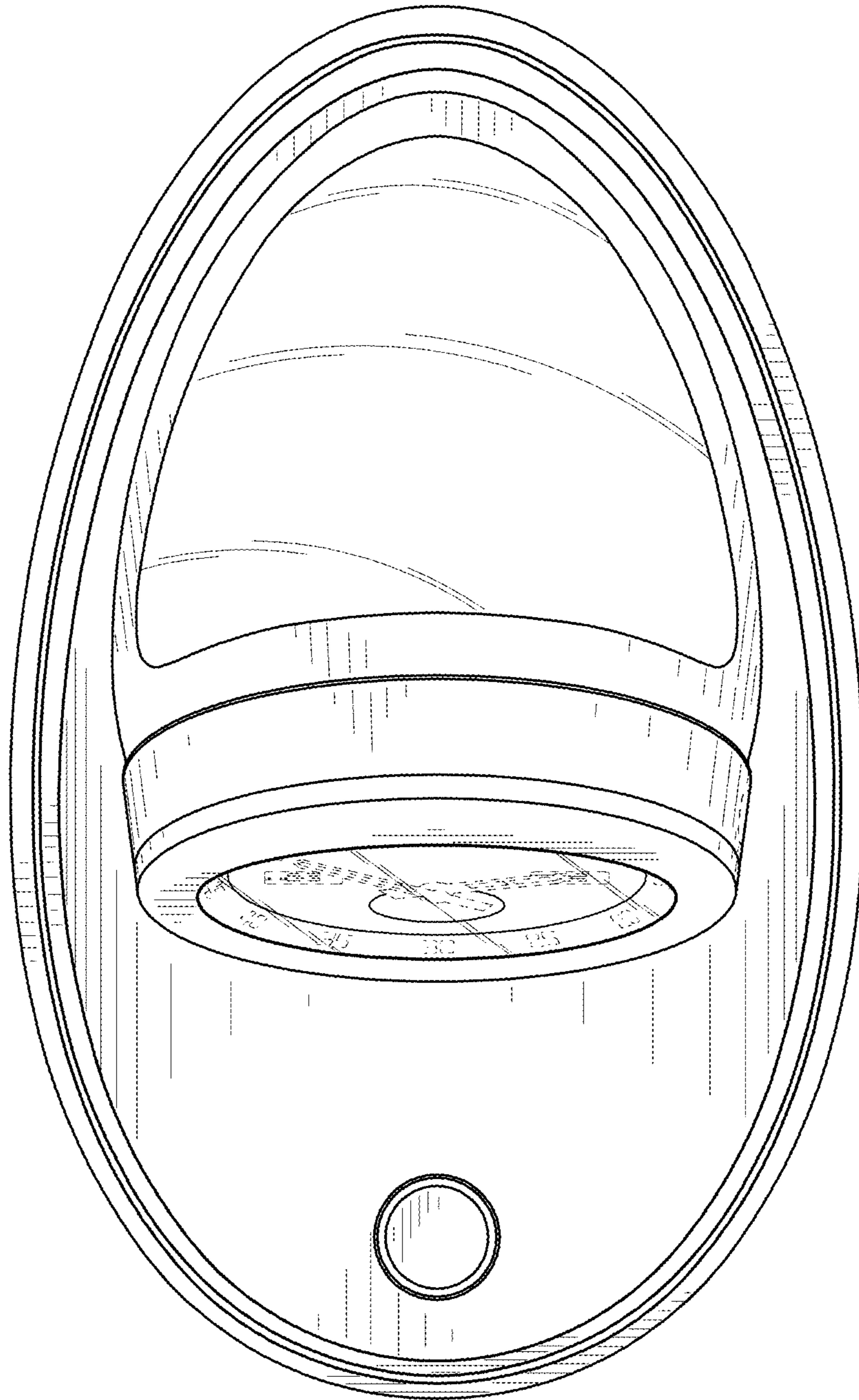

FIG. 6

UNITED STATES PATENT AND TRADEMARK OFFICE
CERTIFICATE OF CORRECTION

PATENT NO. : D833,890 S
APPLICATION NO. : 29/556962
DATED : November 20, 2018
INVENTOR(S) : David Alan Rook et al.

Page 1 of 1

It is certified that error appears in the above-identified patent and that said Letters Patent is hereby corrected as shown below:

On the Title Page

Assignee section should read:

(73) Assignee: Bentley Motors Limited, Cheshire (GB)

Signed and Sealed this
Second Day of July, 2019

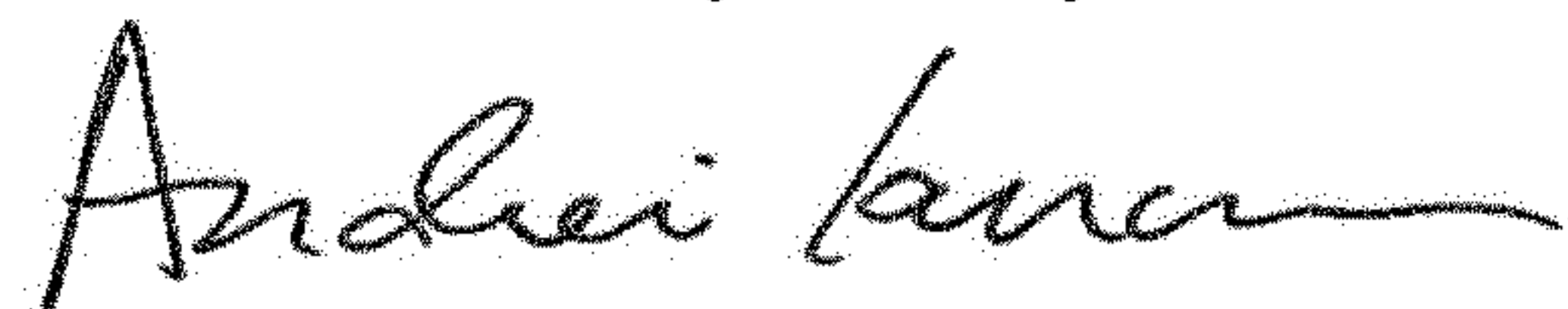

Andrei Iancu
Director of the United States Patent and Trademark Office