

US00D833665S

(12) **United States Design Patent**
Lewis, Jr. et al.

(10) **Patent No.:** **US D833,665 S**
(45) **Date of Patent:** **** Nov. 13, 2018**

(54) **LUMINAIRE WITH CURVED ENDCAPS**

(71) Applicant: **Cooper Technologies Company**,
Houston, TX (US)

(72) Inventors: **Paul W. Lewis, Jr.**, Grantville, GA
(US); **Gregg A. Lehman**, Peachtree
City, GA (US)

(73) Assignee: **Cooper Technologies Company**,
Houston, TX (US)

(**) Term: **15 Years**

(21) Appl. No.: **29/548,669**

(22) Filed: **Dec. 15, 2015**

(51) **LOC (11) Cl.** **26-03**

(52) **U.S. Cl.**

USPC **D26/78**

(58) **Field of Classification Search**

USPC D26/1-6, 22, 72, 74, 78, 88, 89, 93, 106,
D26/113-116, 118, 120, 121, 138;

D13/169, 174; D22/117; D8/305-312

CPC A01G 13/06; C11C 5/006; F21L 17/00;

F21L 4/005; F23D 3/16; F23D 3/18;

F21V 33/0064; F41B 15/022; F41B

15/025

See application file for complete search history.

(56) **References Cited**

U.S. PATENT DOCUMENTS

D133,216 S * 7/1942 Parlato D26/78

D399,329 S * 10/1998 Compton D26/76

D465,869 S * 11/2002 Bodell D26/78

D468,457 S * 1/2003 Shemitz D26/6

D544,139 S * 6/2007 Hargreaves D26/118

D545,484 S * 6/2007 Hargreaves D26/118

D640,821 S * 6/2011 Kocks D26/89

D643,148 S * 8/2011 Jabra D26/120

D674,950 S * 1/2013 Lueken D26/71

D720,875 S * 1/2015 Greenwaldt D26/72

D776,335 S * 1/2017 Fizer D26/138

D808,061 S * 1/2018 Wouters D26/78

* cited by examiner

Primary Examiner — Brandon M Rosati

Assistant Examiner — John A Voytek

(74) *Attorney, Agent, or Firm* — King & Spalding LLP

(57) **CLAIM**

The ornamental design for a luminaire with curved endcaps, as shown and described.

DESCRIPTION

FIG. 1 is a top perspective view of a luminaire with curved endcaps, showing our new design;

FIG. 2 is a bottom perspective view thereof;

FIG. 3 is a bottom plan view thereof;

FIG. 4 is a top plan view thereof;

FIG. 5 is a left-side elevation view thereof, the right-side elevation view begin the same; and,

FIG. 6 is a front elevation view thereof, the rear elevation view being the same.

The broken lines shown represent unclaimed subject matter and form no part of the claimed design.

The area between the curved dash-dot-dot-dash lines represents unclaimed subject matter and forms no part of the claimed design.

1 Claim, 5 Drawing Sheets

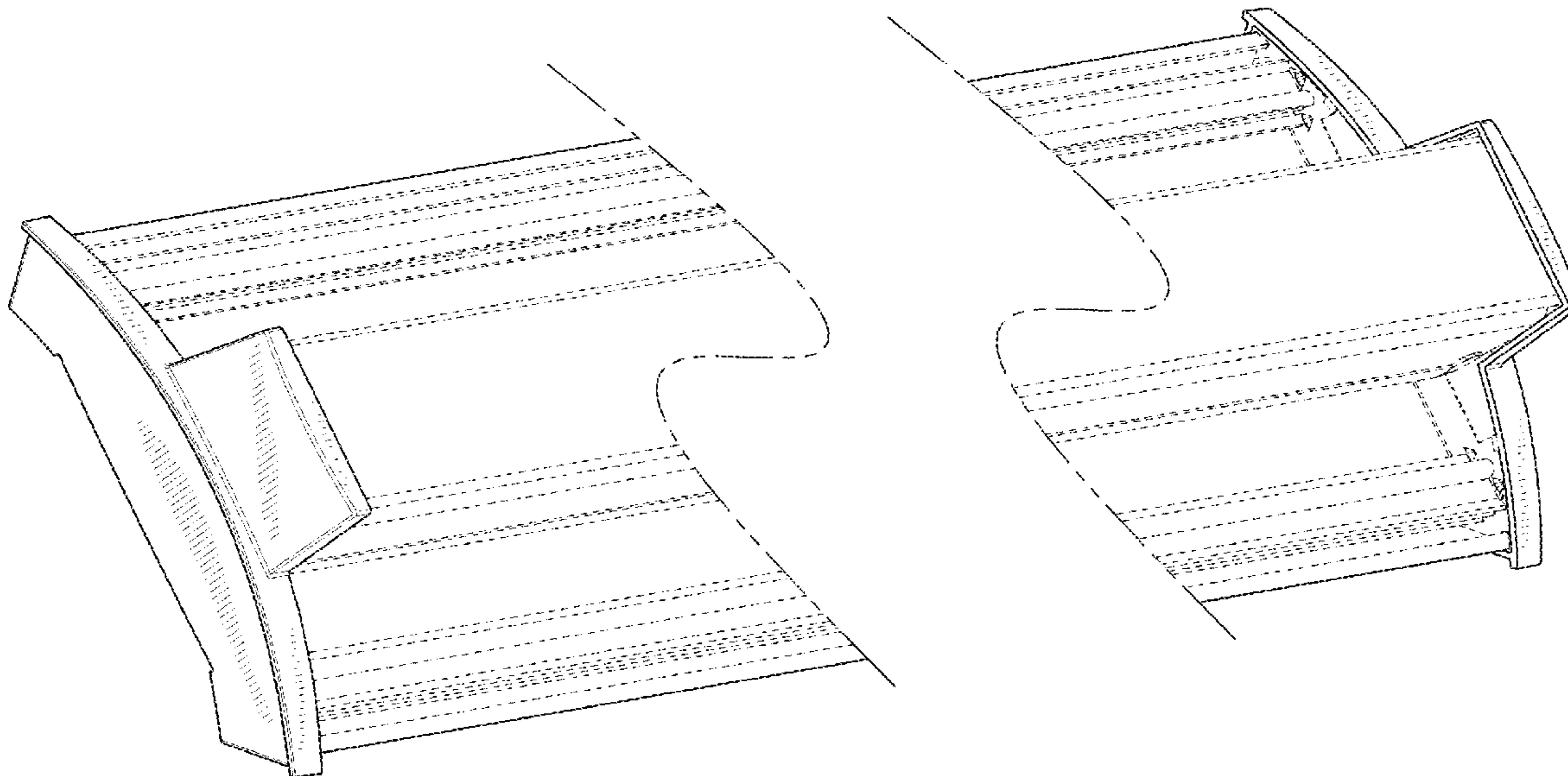

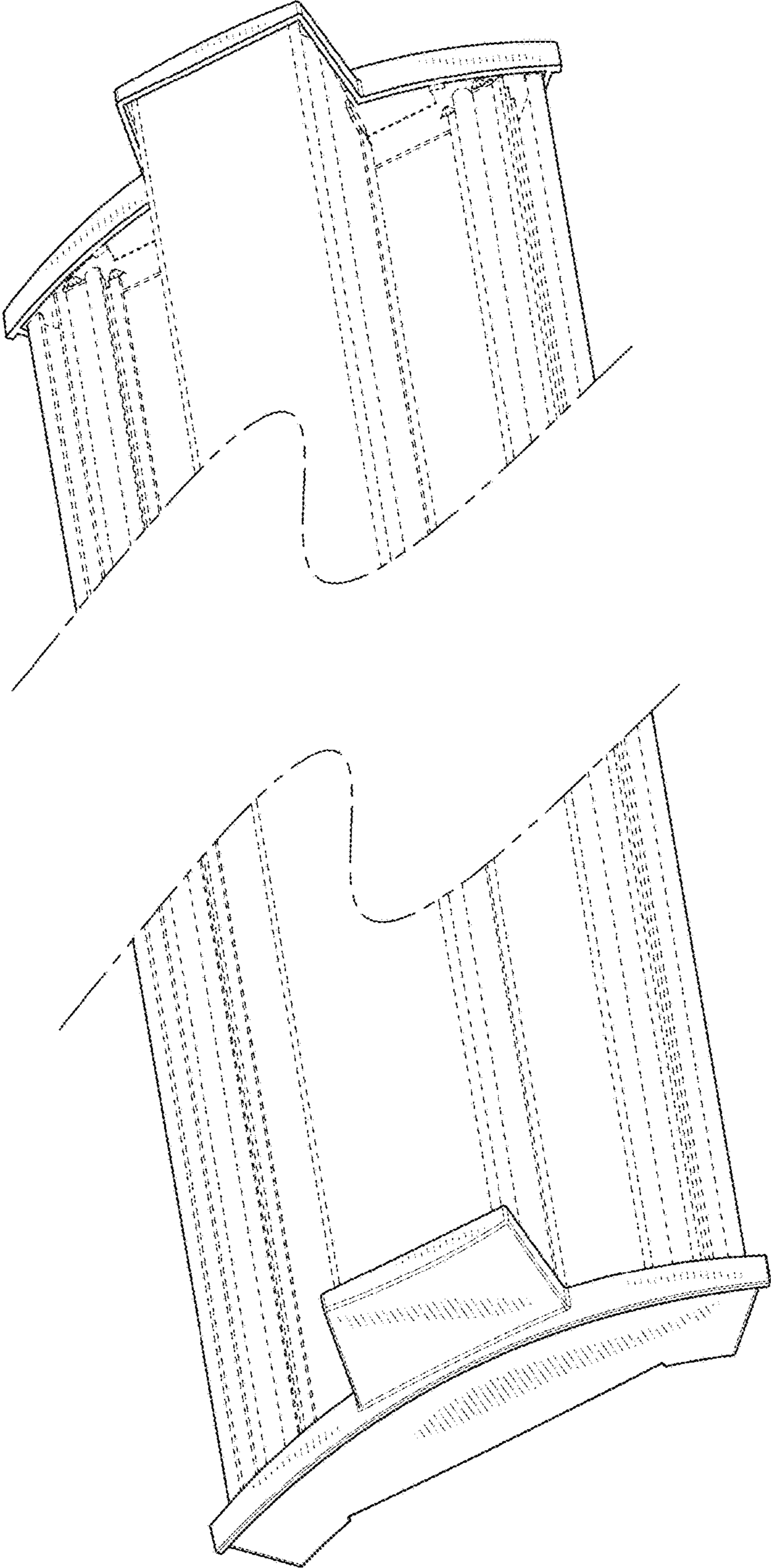

FIG. 1

FIG. 2

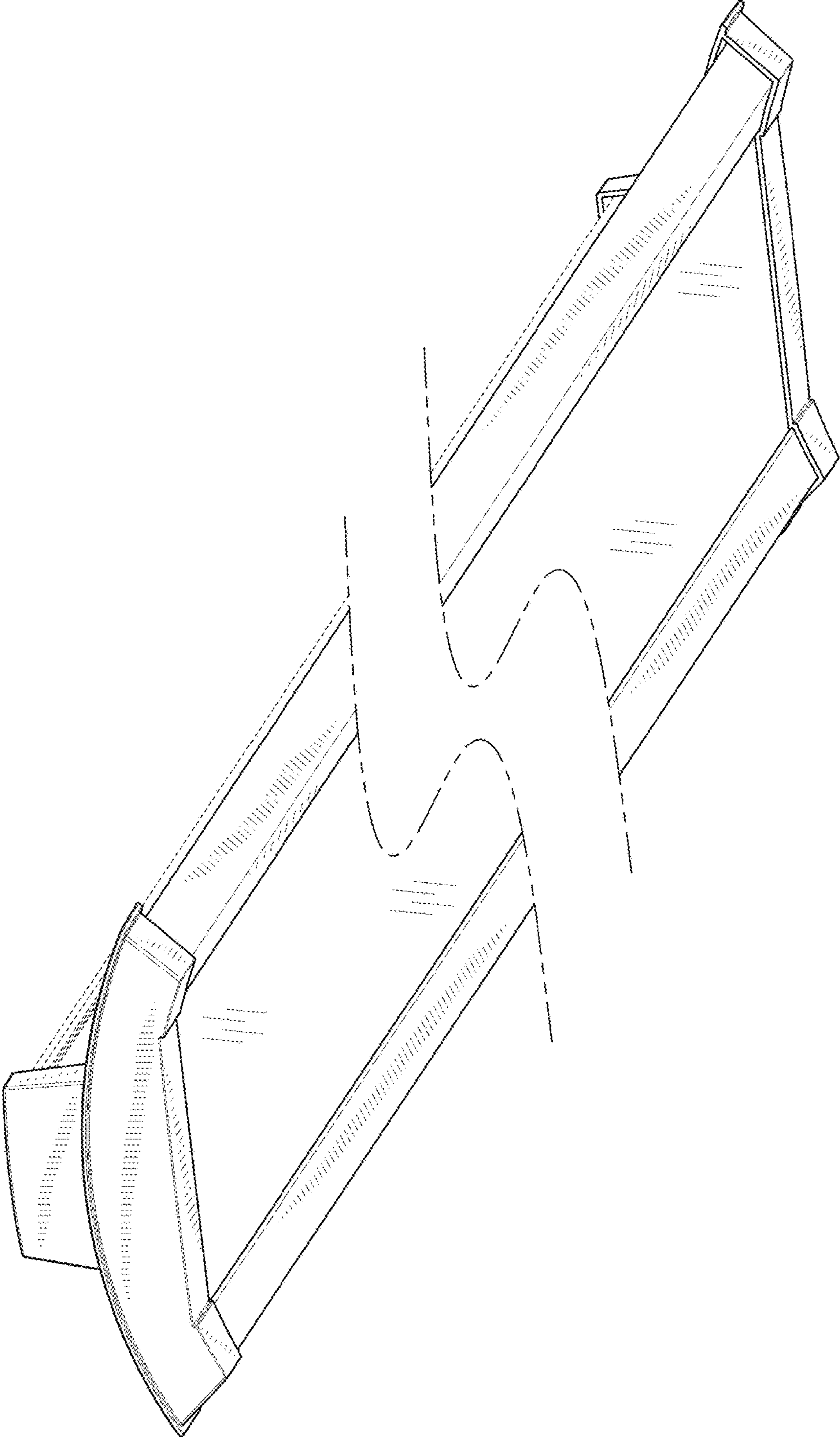
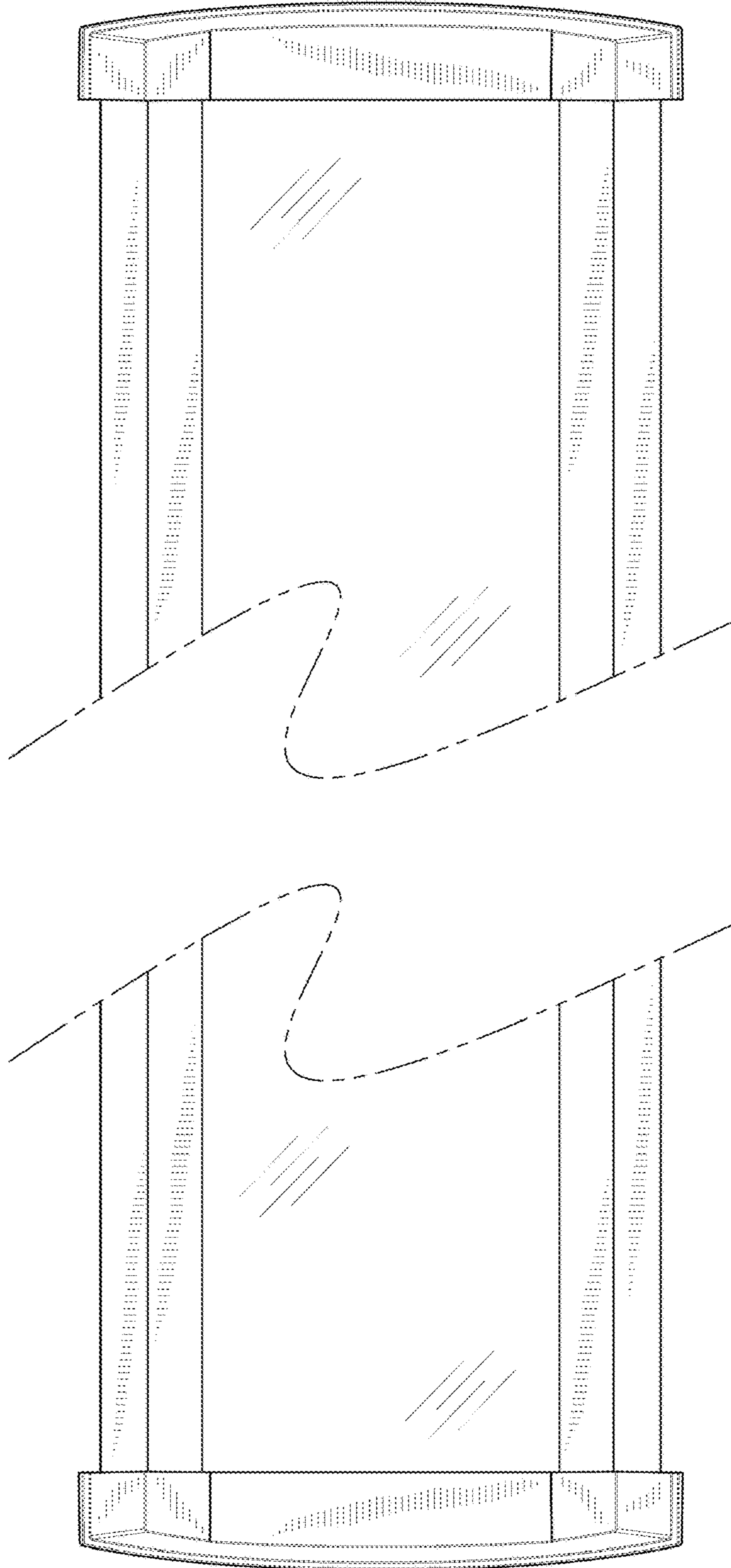

FIG. 3



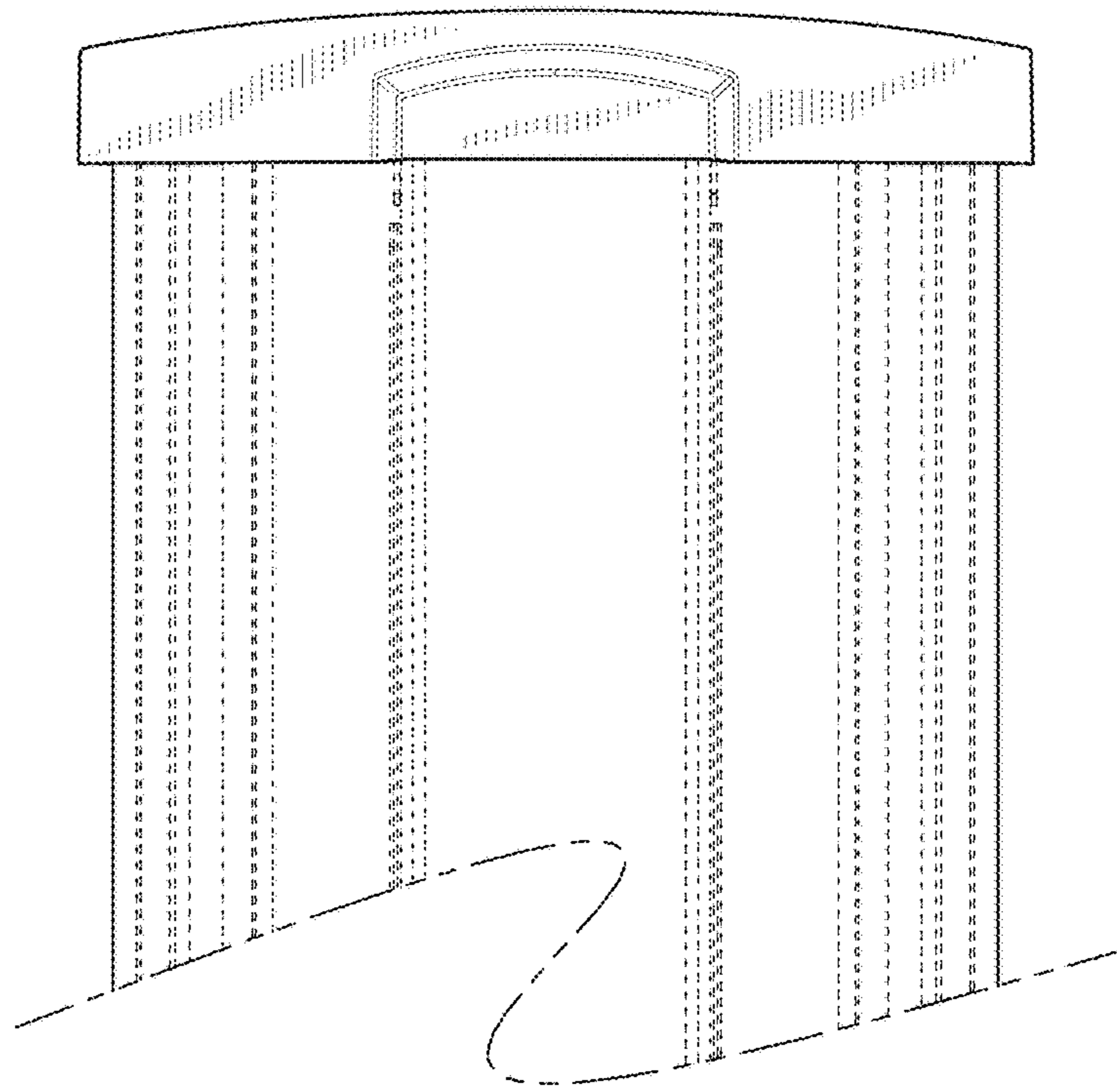

FIG. 4

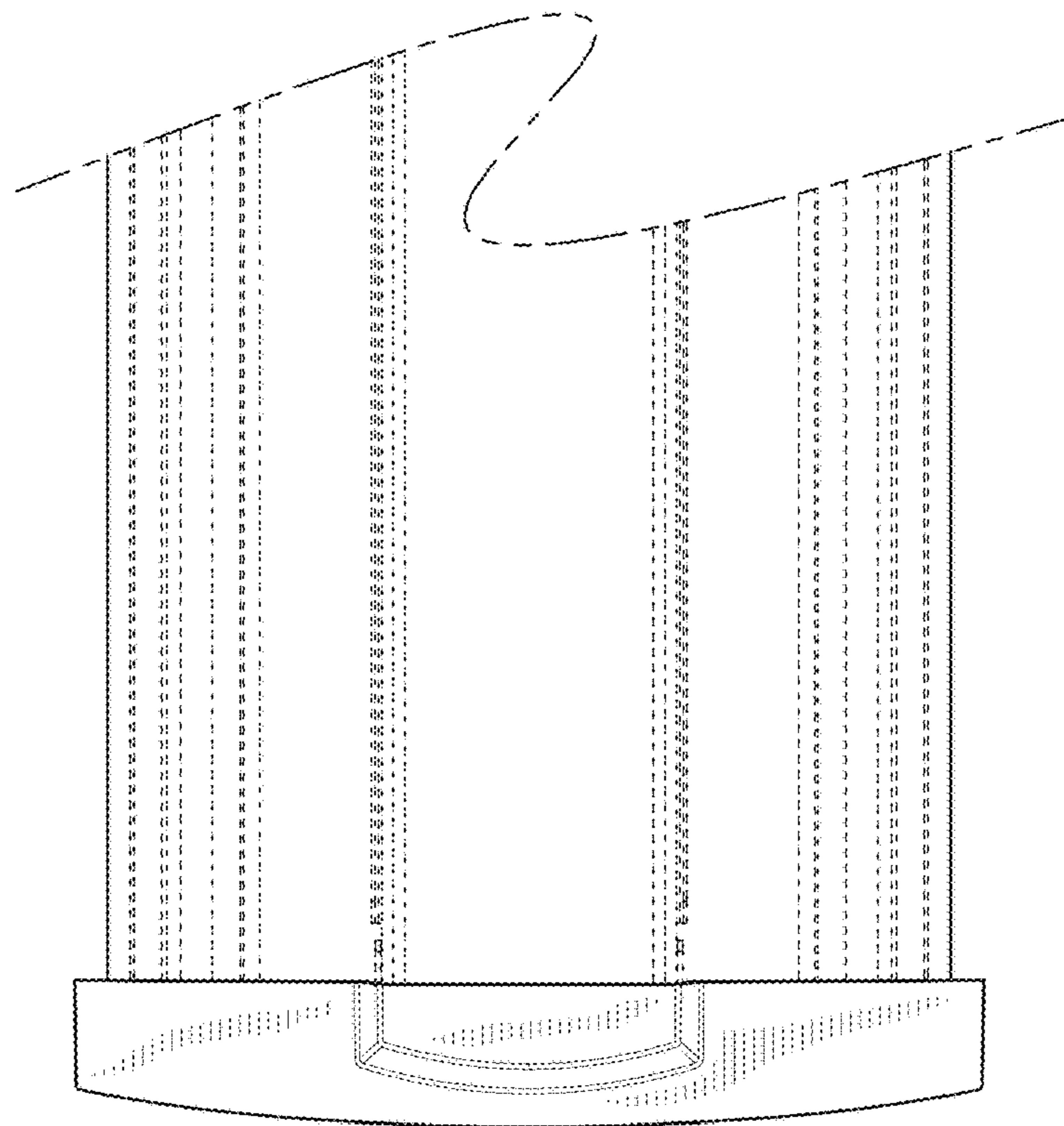

FIG. 5

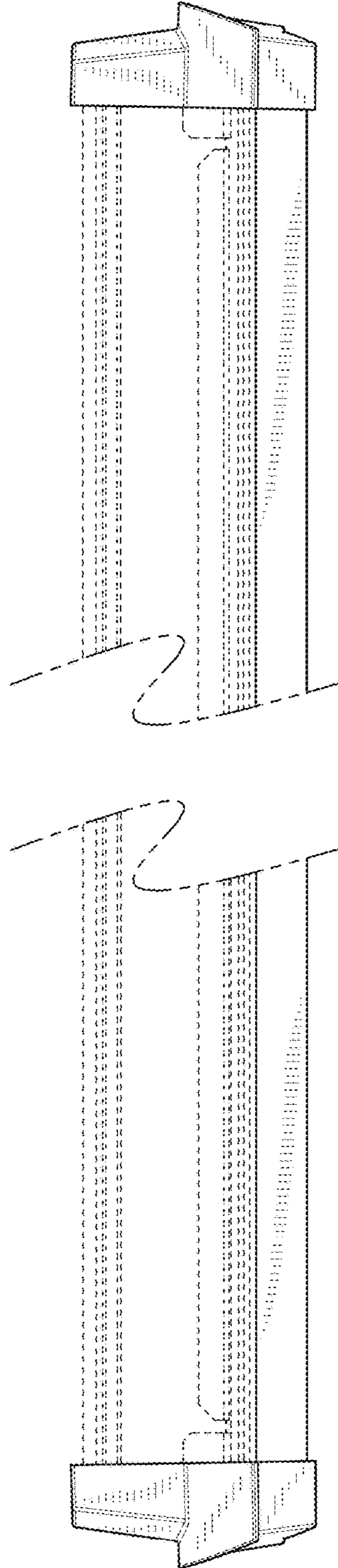

FIG. 6

