



US00D833595S

(12) **United States Design Patent** (10) **Patent No.:** **US D833,595 S**
Busta (45) **Date of Patent:** **** Nov. 13, 2018**

(54) **COMBINATION CEILING FAN AND LIGHT FIXTURE**

(71) Applicant: **Minka Lighting, Inc.**, Corona, CA (US)

(72) Inventor: **Jeff Busta**, La Crescenta, CA (US)

(73) Assignee: **Minka Lighting, Inc.**, Corona, CA (US)

(**) Term: **15 Years**

(21) Appl. No.: **29/632,432**

(22) Filed: **Jan. 8, 2018**

Related U.S. Application Data

(63) Continuation-in-part of application No. 29/590,431, filed on Jan. 10, 2017.

(51) **LOC (11) Cl.** **23-04**

(52) **U.S. Cl.**
USPC **D23/377**

(58) **Field of Classification Search**
USPC D23/370, 377, 379, 385, 411; D26/59
CPC F04D 25/088; F04D 25/06; F04D 29/00;
F24F 7/00; F04B 17/00; H02K 11/001
See application file for complete search history.

(56) **References Cited**

U.S. PATENT DOCUMENTS

D535,011 S * 1/2007 Gajewski D23/377
D536,083 S * 1/2007 Gajewski D23/377

D715,419 S * 10/2014 Schulzman D23/377
D715,421 S * 10/2014 Schulzman D23/413
D721,429 S * 1/2015 Busta D23/377
D721,800 S * 1/2015 Busta D23/413
D750,213 S * 2/2016 Schulzman D23/385
D770,027 S * 10/2016 Noble D23/385
D800,291 S * 10/2017 Wang D23/377
D807,490 S * 1/2018 Ruan D23/377
D807,492 S * 1/2018 Hidalgo D23/377
D807,493 S * 1/2018 Hidalgo D23/377
2007/0104583 A1 * 5/2007 Gajewski F04D 25/088
416/210 R

* cited by examiner

Primary Examiner — Janice Hallmark

(74) *Attorney, Agent, or Firm* — Baker & McKenzie LLP

(57) **CLAIM**

The ornamental design for a combination ceiling fan and light fixture, as shown and described.

DESCRIPTION

FIG. 1 is a perspective view of a combination ceiling fan and light fixture in accordance with my design;
FIG. 2 is a top plan view thereof;
FIG. 3 is a bottom plan view thereof;
FIG. 4 is a front elevation view thereof;
FIG. 5 is a rear elevation view thereof;
FIG. 6 is a left-side elevation view thereof; and,
FIG. 7 is a right-side elevation view thereof.
The broken lines in the drawings illustrate environmental structure that form no part of the claimed design.

1 Claim, 5 Drawing Sheets

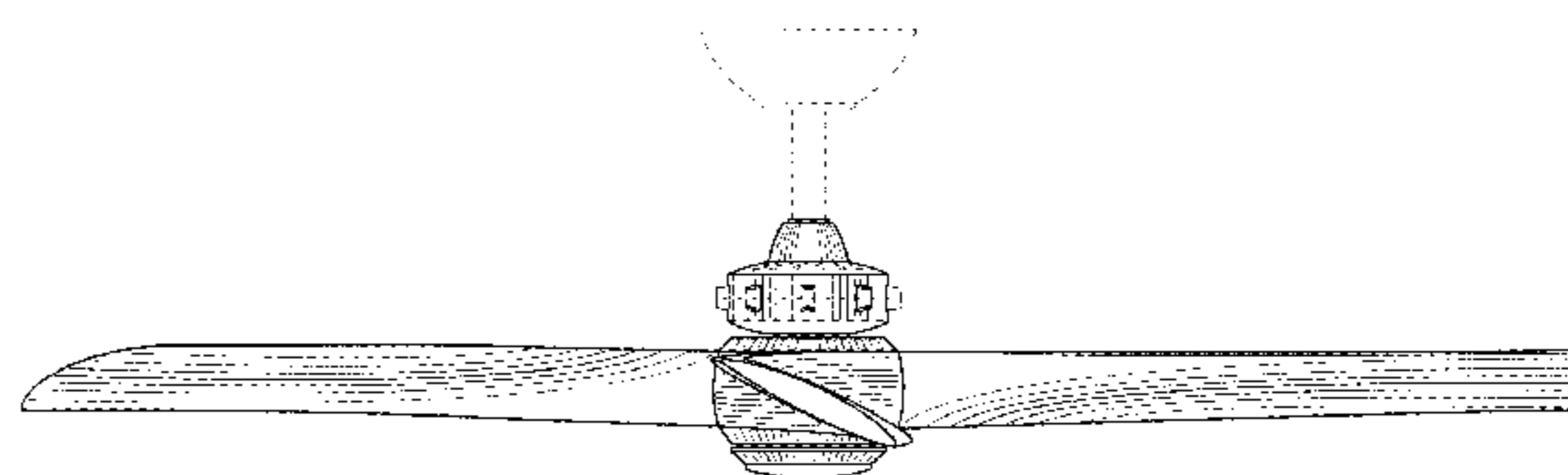
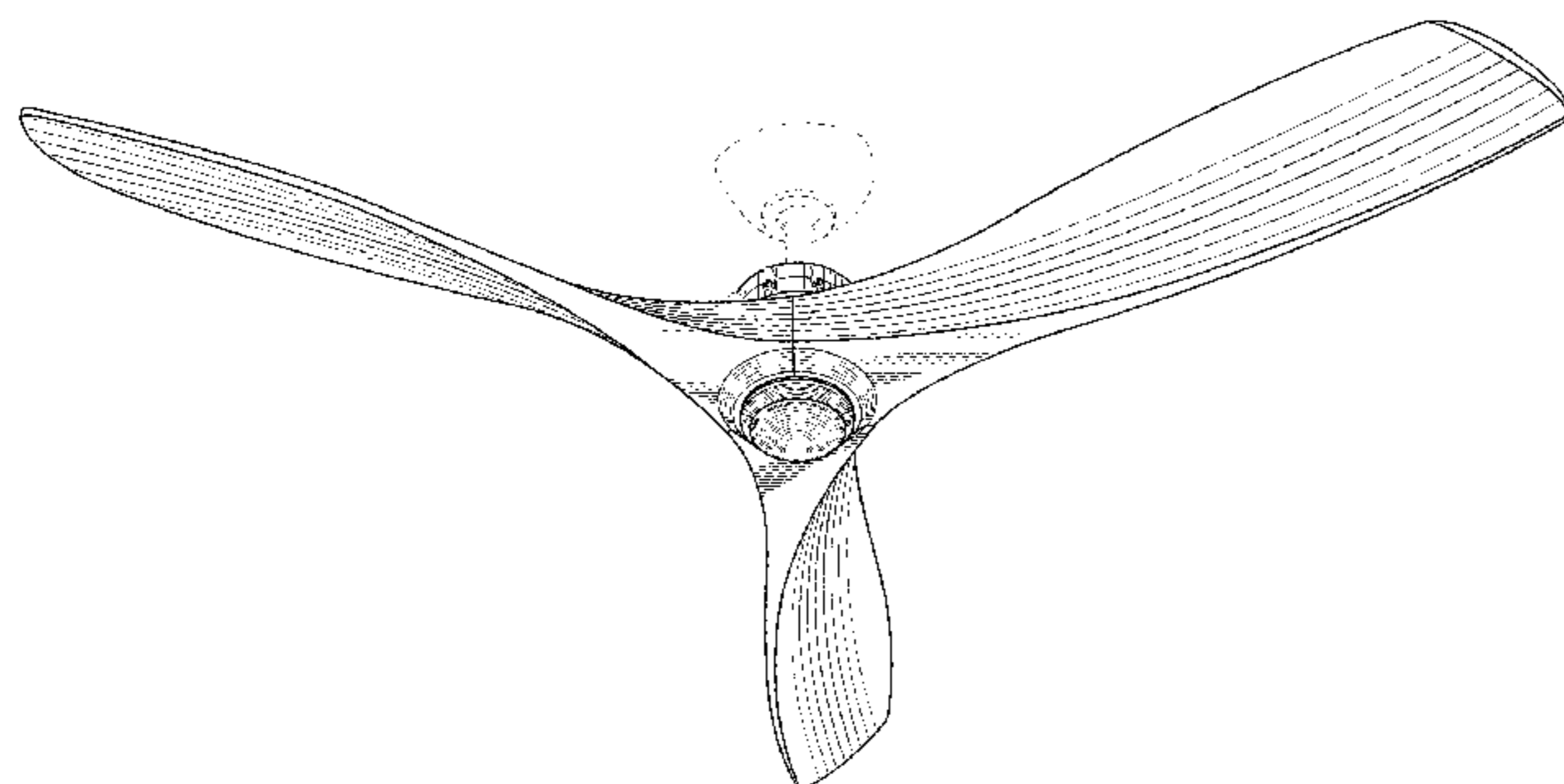

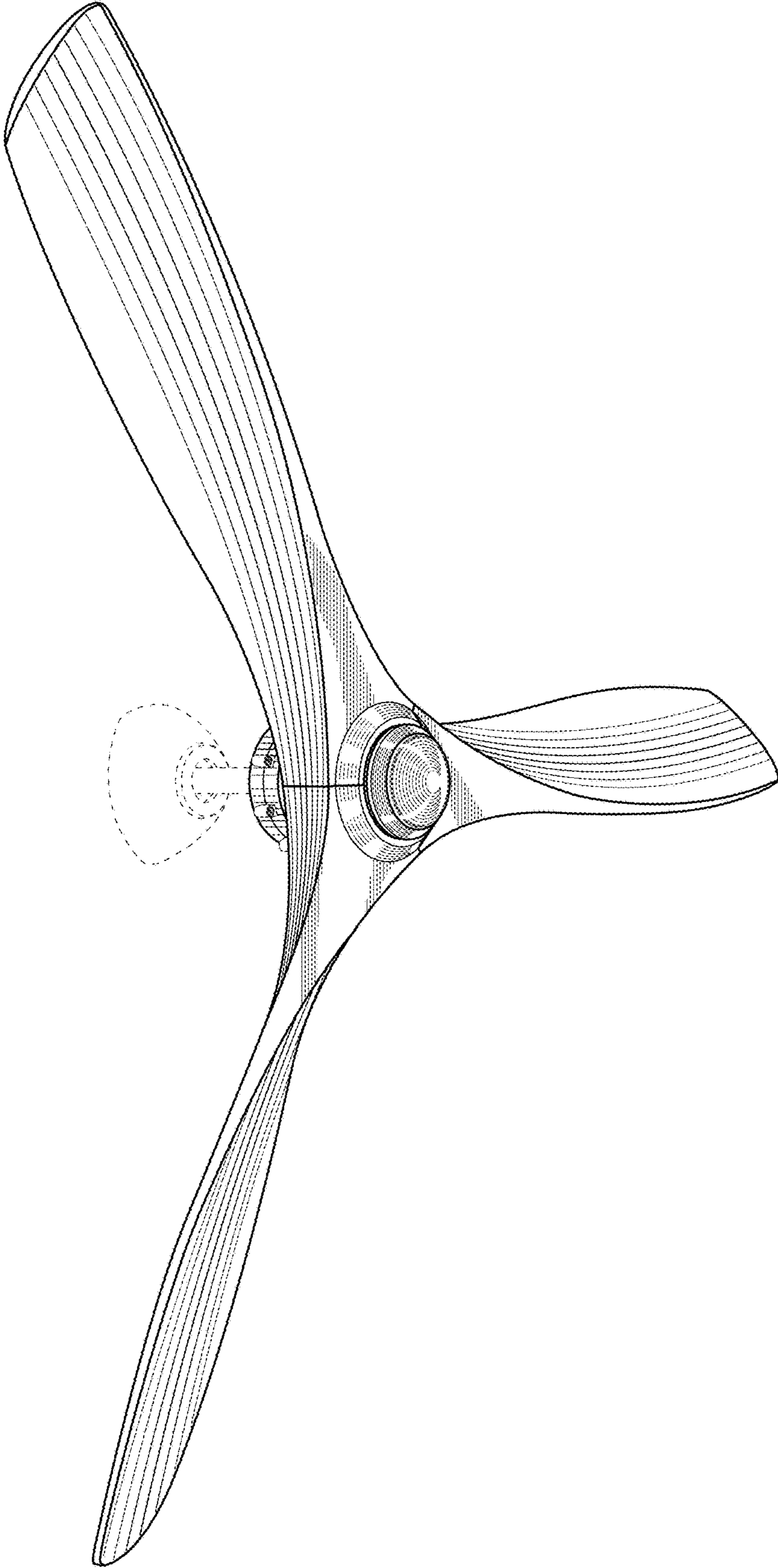

Fig. 1

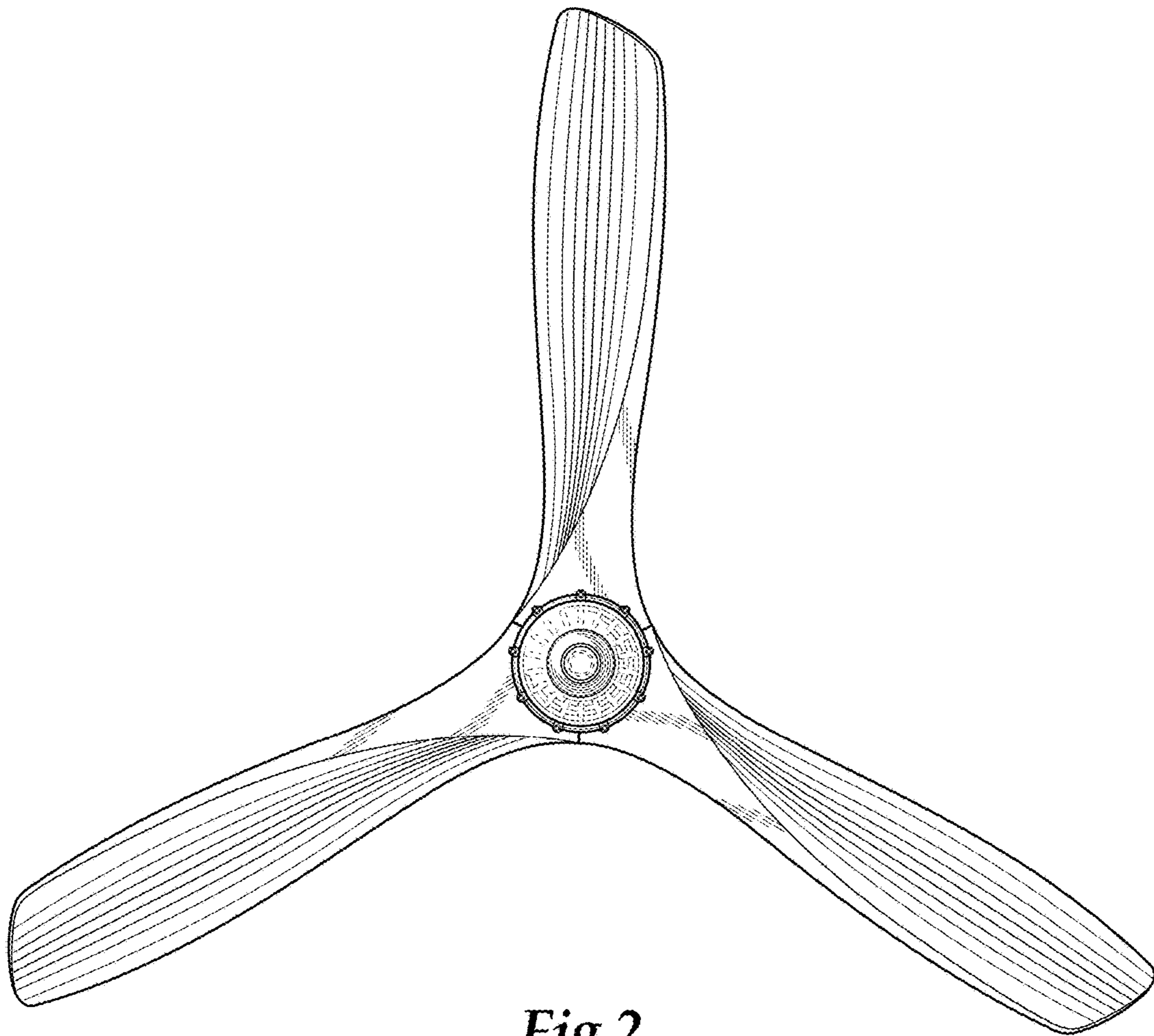

Fig.2

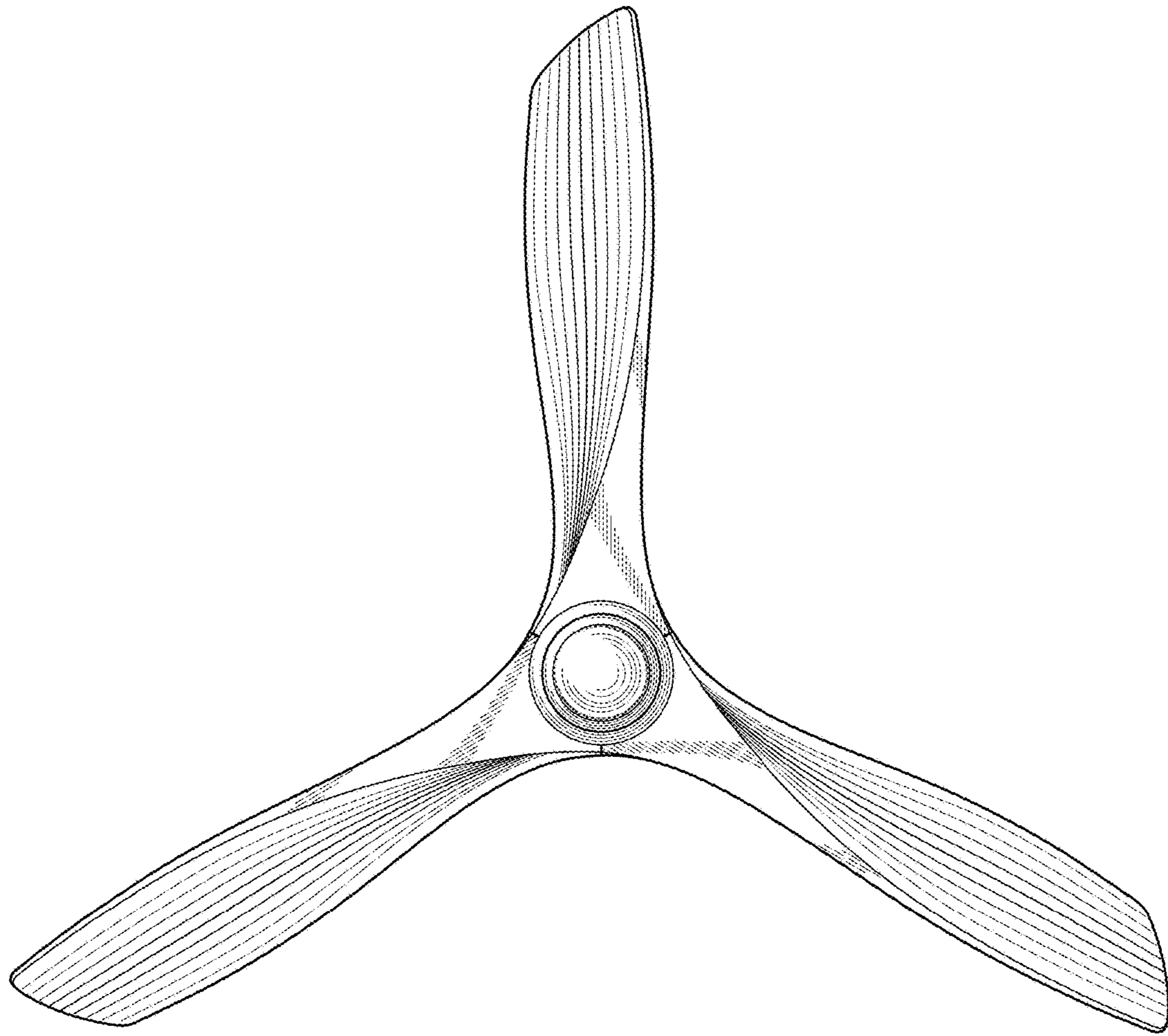

Fig.3

