



US00D833538S

(12) **United States Design Patent** (10) **Patent No.:** **US D833,538 S**  
**Evans** (45) **Date of Patent:** **\*\* Nov. 13, 2018**

(54) **SELF-BALANCING VEHICLE**  
(71) Applicant: **Oliver Evans**, Hong Kong (HK)  
(72) Inventor: **Oliver Evans**, Hong Kong (HK)  
(\*\*) Term: **15 Years**  
(21) Appl. No.: **29/601,754**  
(22) Filed: **Apr. 26, 2017**  
(51) **LOC (11) Cl.** ..... **21-01**  
(52) **U.S. Cl.**  
USPC ..... **D21/421**; D21/423; D12/1  
(58) **Field of Classification Search**  
USPC ..... D21/419, 421, 423, 424, 432, 760, 765;  
D12/1, 107  
CPC .... B62K 3/002; B62K 3/007; B62K 2202/00;  
B62K 11/00; B62K 2204/00; B62K  
21/005; B62D 51/02; B62D 51/005;  
B62D 37/00  
See application file for complete search history.

D774,600 S \* 12/2016 Tao ..... D12/1  
D774,956 S \* 12/2016 Tanaka ..... D12/107  
D783,751 S 4/2017 Yao  
D786,130 S 5/2017 Huang  
D795,133 S \* 8/2017 Sagawa ..... D12/1  
2011/0070997 A1\* 3/2011 Gomi ..... B60B 9/06  
476/66  
2011/0209932 A1\* 9/2011 Takenaka ..... B60B 19/003  
180/15  
2012/0078482 A1\* 3/2012 Takenaka ..... B62K 11/007  
701/70

\* cited by examiner

*Primary Examiner* — Cynthia M. Chin  
(74) *Attorney, Agent, or Firm* — Wayne & King LLC

(57) **CLAIM**

The ornamental design for a self-balancing vehicle, as shown and described.

**DESCRIPTION**

FIG. 1 is a front view of a self-balancing vehicle showing my new design;  
FIG. 2 is a rear view thereof;  
FIG. 3 is a left side view thereof;  
FIG. 4 is a right side view thereof;  
FIG. 5 is a top plan view thereof;  
FIG. 6 is a bottom plan view thereof;  
FIG. 7 is a front side perspective view thereof; and,  
FIG. 8 is a rear side perspective view thereof.  
The broken lines in the drawing depict portions of the self-balancing vehicle that form no part of the claimed design.

**1 Claim, 7 Drawing Sheets**

(56) **References Cited**  
U.S. PATENT DOCUMENTS  
1,652,934 A \* 12/1927 Gillespie ..... A63B 25/04  
280/205  
2,971,773 A \* 2/1961 McKissick ..... B62K 1/00  
188/5  
6,561,294 B1 \* 5/2003 Kamen ..... B62D 37/00  
180/21  
D528,468 S \* 9/2006 Arling ..... D12/1  
7,963,352 B2 \* 6/2011 Alexander ..... B62K 1/00  
180/21  
8,499,864 B2 \* 8/2013 Takenaka ..... B60B 19/003  
180/10  
9,188,984 B2 \* 11/2015 Kamen ..... A63C 17/01

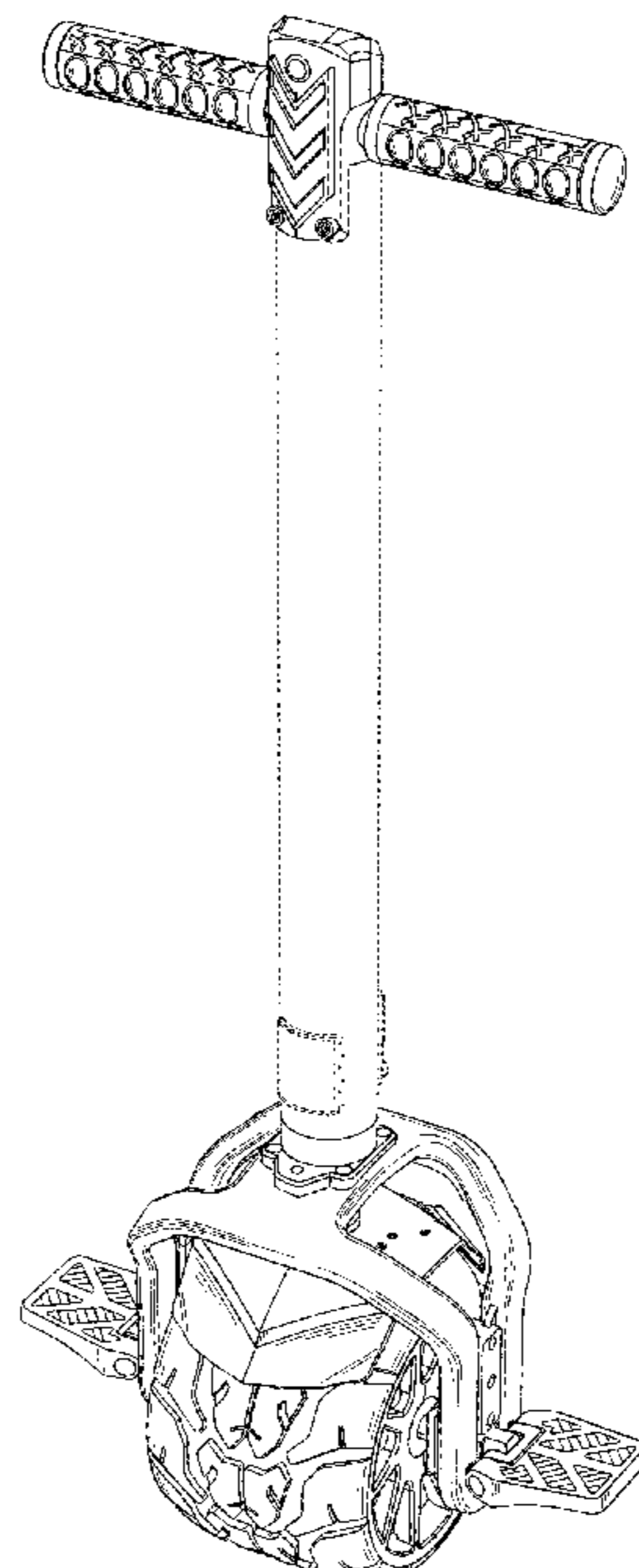

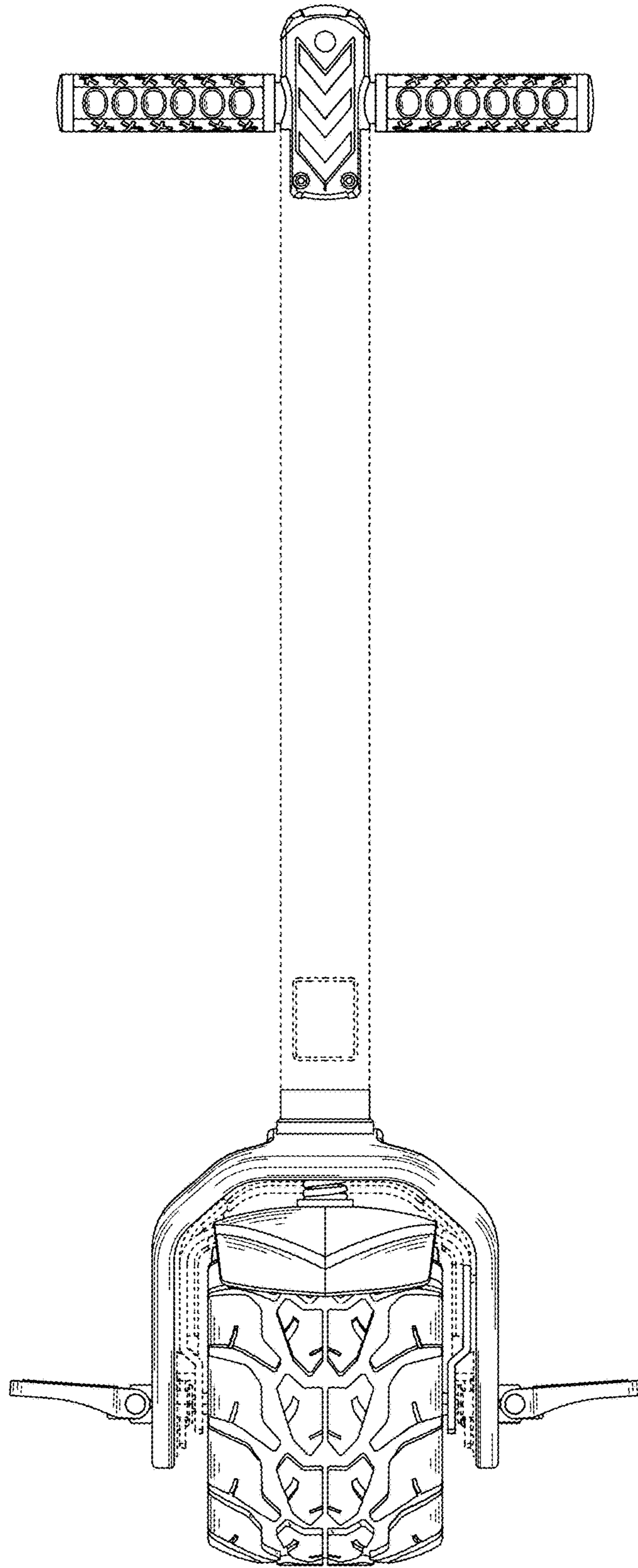

FIG.1

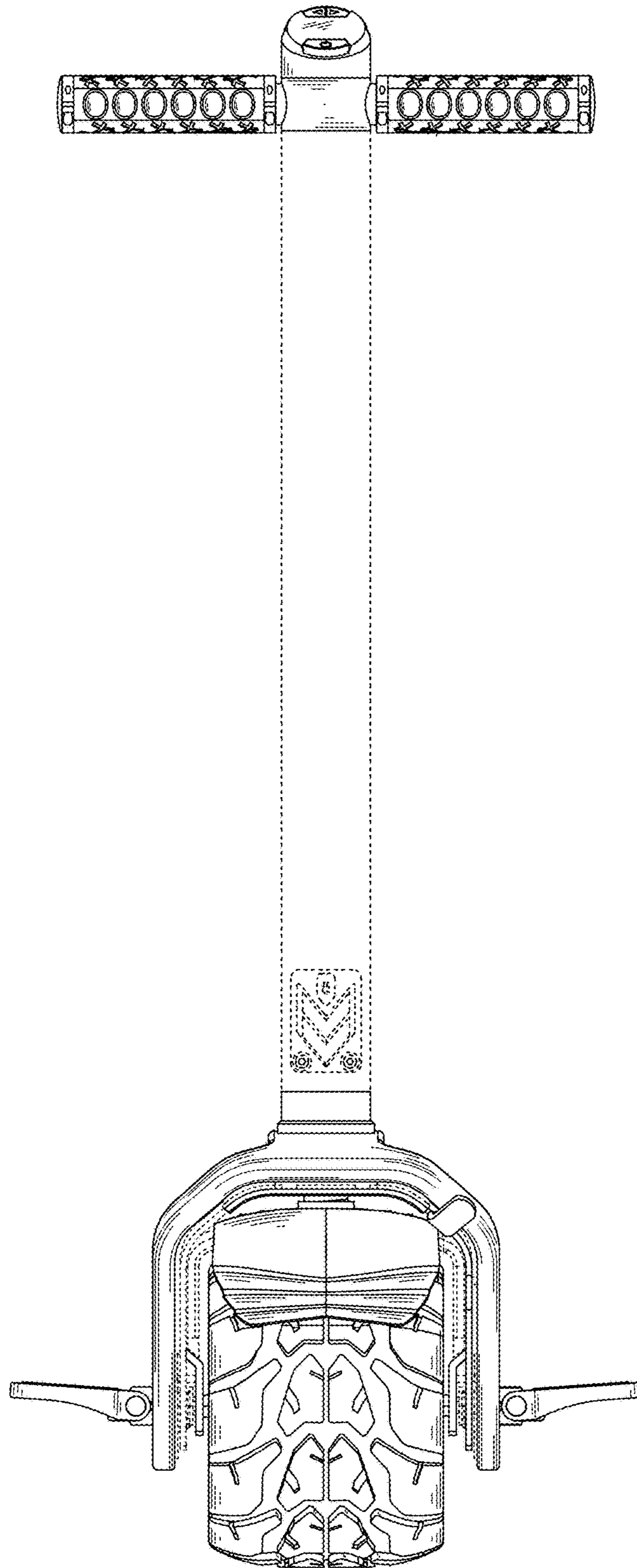

FIG. 2

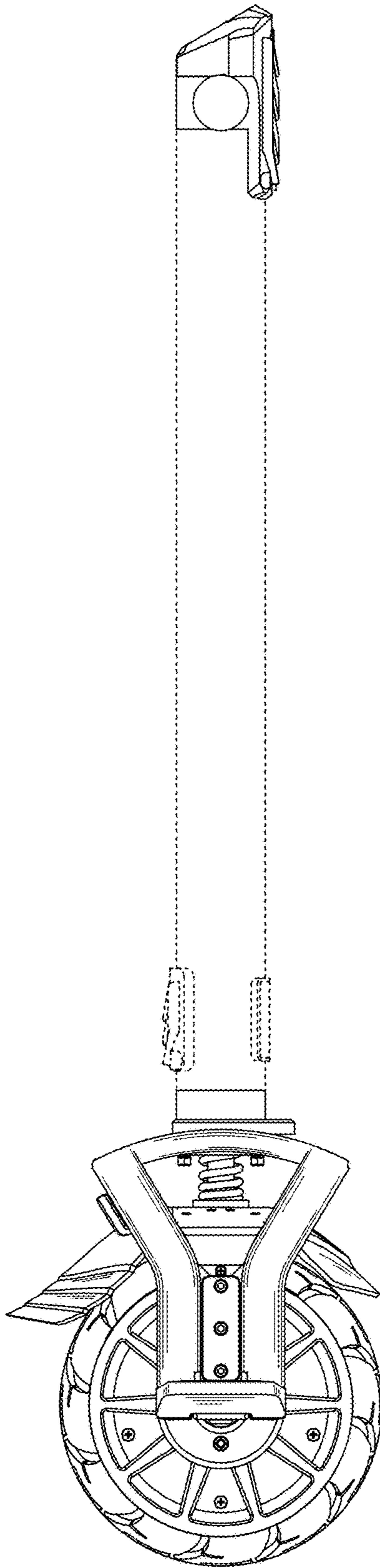

FIG. 3

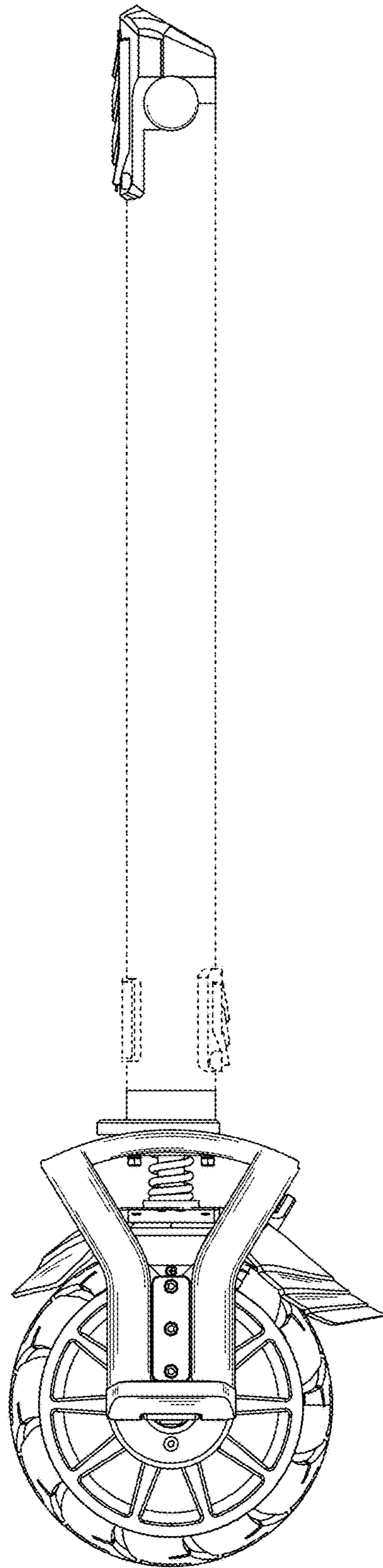

FIG. 4

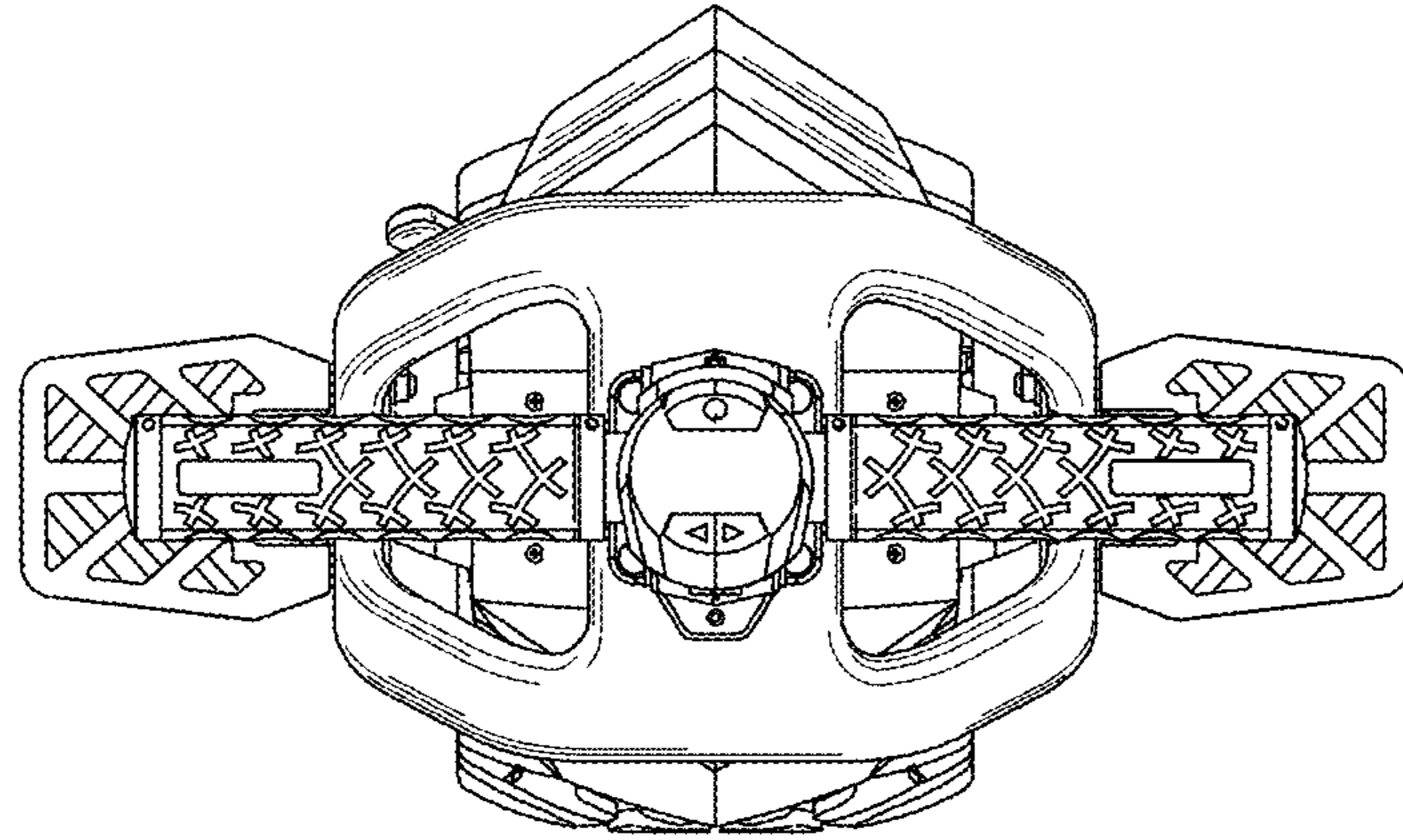

FIG. 5

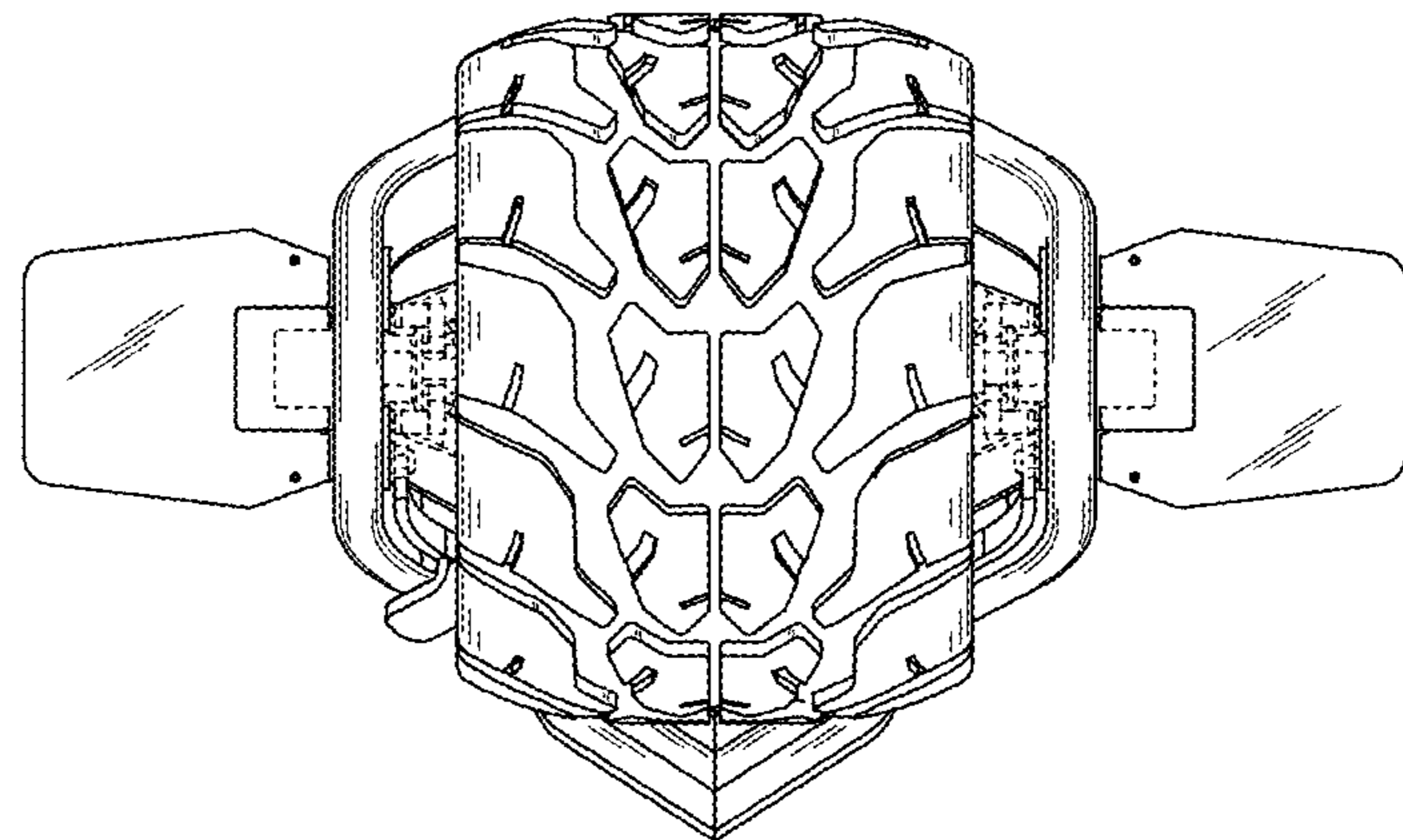

FIG. 6

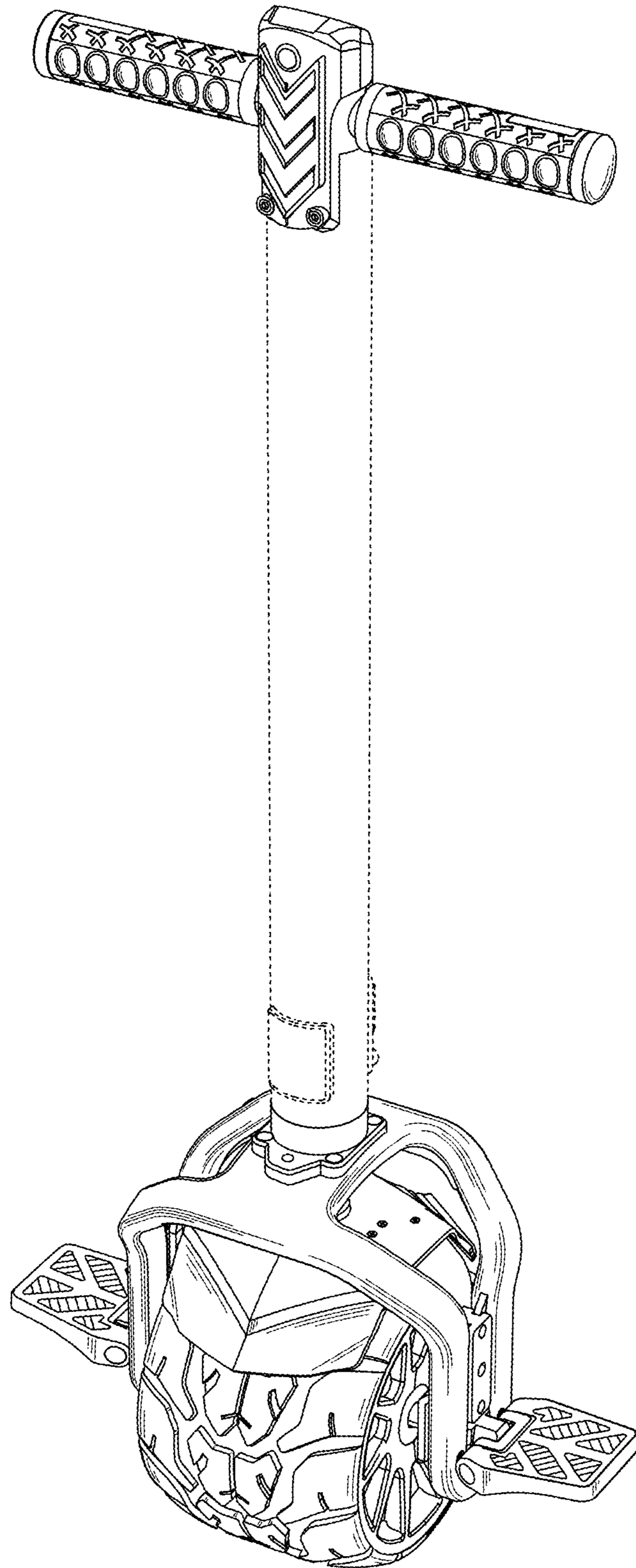

FIG. 7

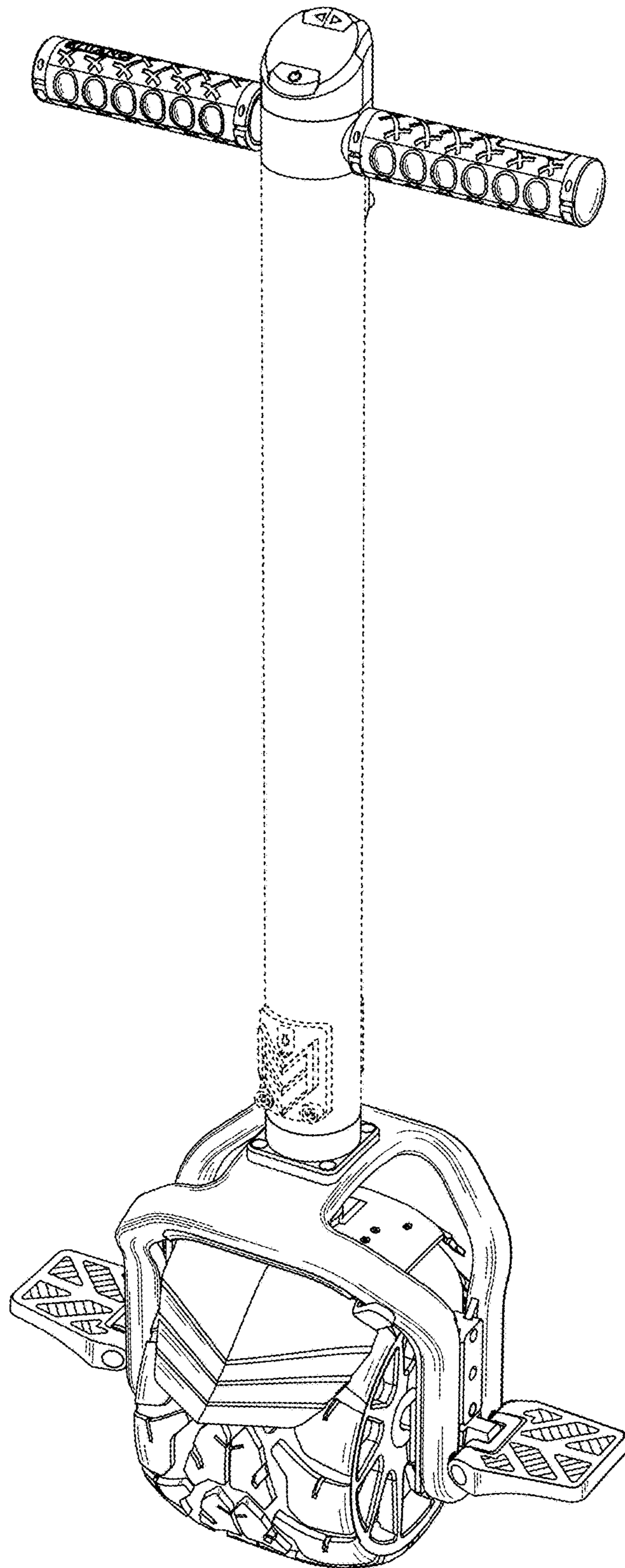

FIG. 8