



US00D832418S

(12) **United States Design Patent**
Porter et al.

(10) **Patent No.:** **US D832,418 S**
(45) **Date of Patent:** **** Oct. 30, 2018**

- (54) **ORAL IRRIGATOR BASE**
- (71) Applicant: **WATER PIK, INC.**, Fort Collins, CO (US)
- (72) Inventors: **Austin Rand Porter**, Seattle, WA (US); **Jeffrey Ladwig**, Seattle, WA (US)
- (73) Assignee: **WATER PIK, INC.**, Fort Collins, CO (US)
- (**) Term: **15 Years**
- (21) Appl. No.: **29/587,854**
- (22) Filed: **Dec. 15, 2016**
- (51) **LOC (11) Cl.** **29-02**
- (52) **U.S. Cl.**
USPC **D24/111**
- (58) **Field of Classification Search**
USPC D24/108, 111-113, 133, 152, 176;
D4/101, 138
See application file for complete search history.

2,709,227 A	5/1955	Foley et al.	
2,733,713 A	2/1956	Kabnick	
2,783,919 A	3/1957	Ansell	
2,794,437 A	6/1957	Tash	
2,870,932 A	1/1959	Davis	
2,984,452 A	5/1961	Hooper	
3,089,490 A	5/1963	Goldberg	
3,096,913 A	7/1963	Jousson	
3,144,867 A	8/1964	Trupp et al.	
D202,041 S	8/1965	Burzloff	
3,209,956 A	10/1965	McKenzie	
3,216,619 A	11/1965	Richards et al.	
3,225,759 A	12/1965	Drapen et al.	
3,227,158 A	1/1966	Mattingly	
3,266,623 A	8/1966	Poferl	
3,297,558 A	1/1967	Hillquist	
D208,778 S	10/1967	Koch	
D209,202 S	11/1967	Fulton et al.	
D209,203 S	11/1967	Mattingly et al.	
D209,204 S	11/1967	St. Clair et al.	
D209,395 S	11/1967	Gilbert	
D210,018 S	1/1968	Mattingly et al.	
D210,019 S *	1/1968	Johnson et al.	601/162
3,370,214 A	2/1968	Aymar	
3,391,696 A	7/1968	Woodward	
3,393,673 A	7/1968	Mattingly et al.	
3,400,999 A	9/1968	Goldstein	
3,418,552 A	12/1968	Holmes	
3,420,228 A	1/1969	Kalbfeld	
3,425,410 A	2/1969	Cammack	
3,453,969 A	7/1969	Mattingly	
3,465,751 A	9/1969	Powers	
3,467,083 A	9/1969	Mattingly	
3,467,286 A	9/1969	Ostrowsky	
D215,920 S	11/1969	McCarty et al.	
3,487,828 A	1/1970	Troy	
3,489,268 A	1/1970	Meierhoefer	
3,495,587 A	2/1970	Freedman	
3,496,933 A	2/1970	Lloyd	
3,499,440 A	3/1970	Gibbs	
3,500,824 A	3/1970	Gilbert	
3,501,203 A	3/1970	Falk	
3,502,072 A	3/1970	Stillman	
3,517,669 A	6/1970	Buono et al.	
D218,270 S	8/1970	Soper	
3,522,801 A	8/1970	Robinson	
3,532,221 A	10/1970	Kaluhiokalani et al.	
3,536,065 A	10/1970	Moret	
3,537,444 A	11/1970	Garn	
3,538,950 A	11/1970	Porteners	
3,547,110 A	12/1970	Balamuth	
3,561,433 A	2/1971	Kovach	
D220,334 S	3/1971	Mackay et al.	

(56) **References Cited**
U.S. PATENT DOCUMENTS

555,588 A	3/1896	Spencer
1,278,225 A	9/1918	Schamberg
1,452,258 A	4/1923	Smith
1,464,419 A	8/1923	Gill
1,480,310 A	1/1924	Smith
1,498,267 A	6/1924	Hachman
1,602,742 A	10/1926	Bennet
1,650,686 A	11/1927	Binks
1,669,889 A	5/1928	Andrews et al.
1,681,320 A	8/1928	Bergl et al.
1,933,454 A	10/1933	Sidney
1,940,111 A	12/1933	Austin
D93,019 S	8/1934	Hose
1,977,782 A	10/1934	Roy
2,107,686 A	2/1938	Bramsen et al.
2,421,498 A	6/1947	Guedel
D159,872 S	8/1950	Skold
2,531,730 A	11/1950	Henderson
2,595,666 A	5/1952	Hutson
2,669,233 A	2/1954	Friend

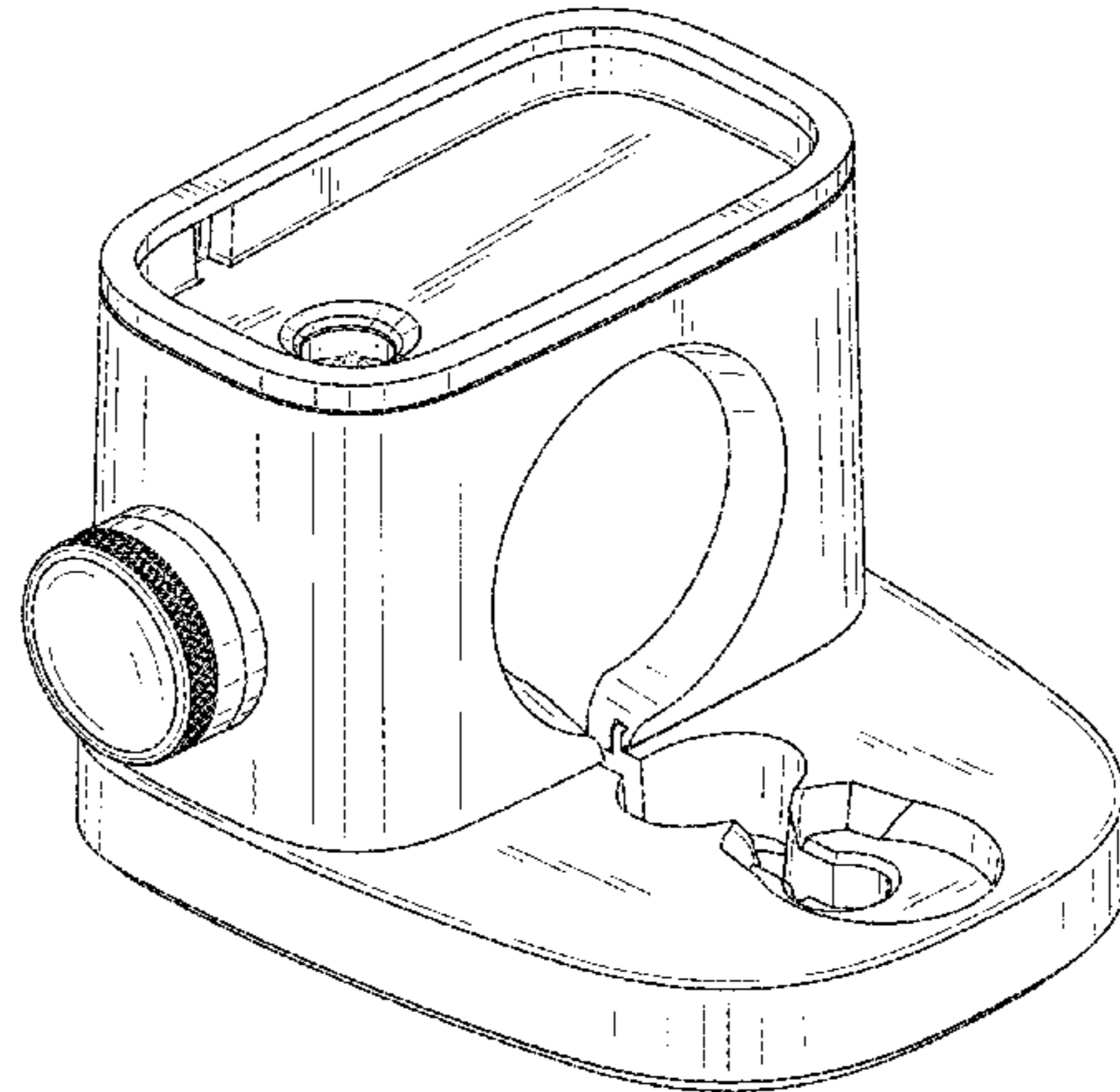
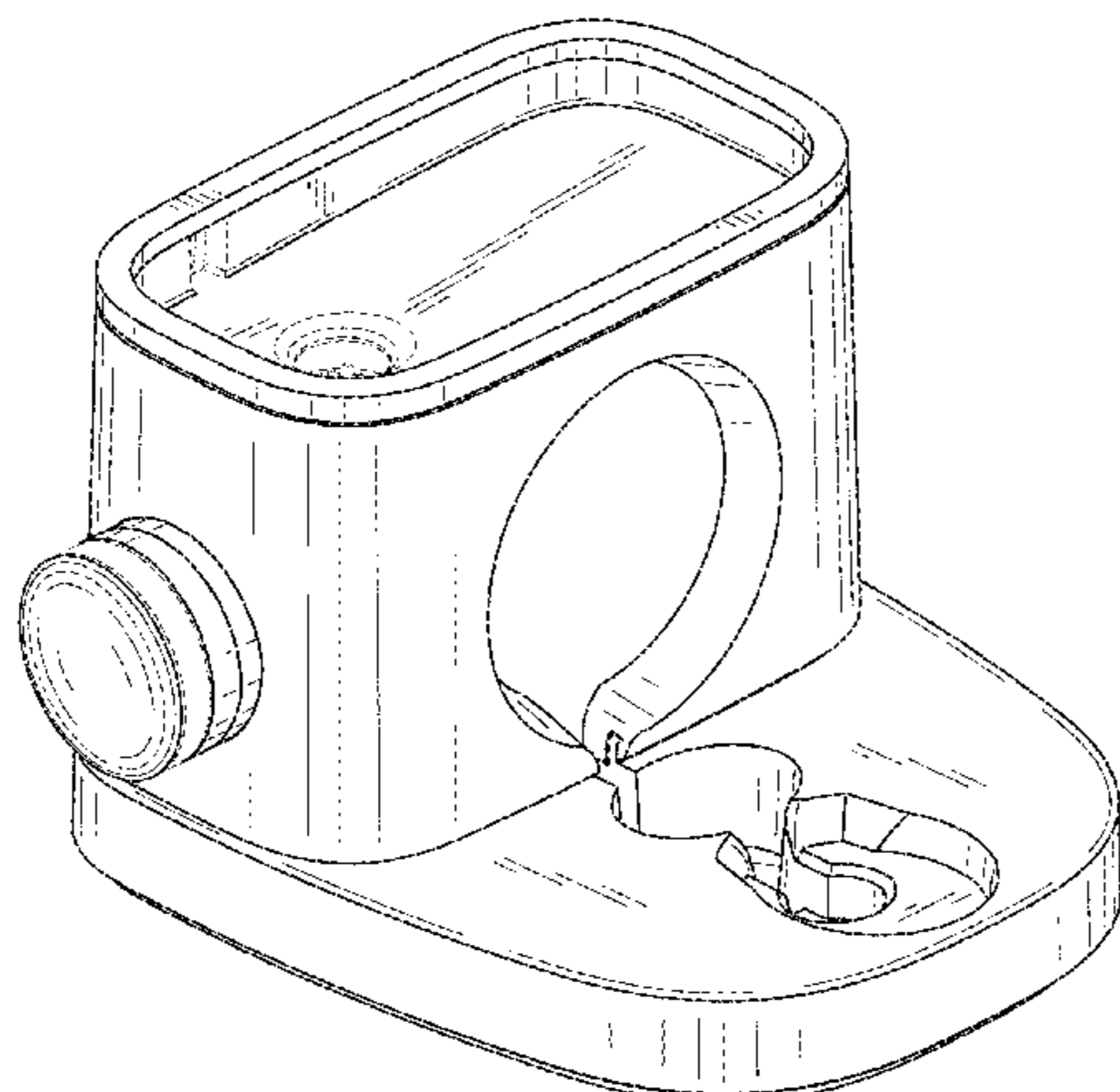

US D832,418 S

Page 2

3,570,525 A	3/1971	Borsum	4,303,070 A	12/1981	Ichikawa et al.
3,572,375 A	3/1971	Rosenberg	4,306,862 A	12/1981	Knox
3,578,884 A	5/1971	Jacobson	4,315,741 A	2/1982	Reichl
D220,996 S	6/1971	Irons	4,319,568 A	3/1982	Tregoning
3,583,609 A	6/1971	Oppenheimer	4,331,422 A	5/1982	Heyman
3,590,813 A	7/1971	Roszyk	4,337,040 A	6/1982	Cammack et al.
3,608,548 A	9/1971	Lewis	4,340,365 A	7/1982	Pisanu
3,612,045 A	10/1971	Dudas	4,340,368 A	7/1982	Lococo
D222,862 S	1/1972	Cook	D266,117 S	9/1982	Oberheim
3,636,947 A	1/1972	Balamuth	4,353,694 A	10/1982	Pelerin
3,651,576 A	3/1972	Massa	4,363,626 A	12/1982	Schmidt et al.
3,669,101 A	6/1972	Kleiner	4,365,376 A	12/1982	Oda et al.
3,703,170 A	11/1972	Ryckman, Jr.	4,370,131 A	1/1983	Banko
3,718,974 A	3/1973	Buchtel et al.	4,374,354 A	2/1983	Petrovic et al.
3,747,595 A	7/1973	Grossan	4,382,167 A	5/1983	Maruyama et al.
3,768,472 A	10/1973	Hodosh et al.	4,382,786 A	5/1983	Lohn
3,771,186 A	11/1973	Moret et al.	D270,000 S	8/1983	Ketler
3,783,364 A	1/1974	Gallanis et al.	4,396,011 A	8/1983	Mack et al.
3,809,506 A	5/1974	Malcosky	4,412,823 A	11/1983	Sakai et al.
3,809,977 A	5/1974	Balamuth et al.	4,416,628 A	11/1983	Cammack
3,811,432 A	5/1974	Moret	4,442,830 A	4/1984	Markau
3,820,532 A	6/1974	Eberhardt et al.	4,442,831 A	4/1984	Trenary
3,827,147 A	8/1974	Condon	4,452,238 A	6/1984	Kerr
3,837,166 A	9/1974	Hiraoka	4,454,866 A	6/1984	Fayen
3,840,795 A	10/1974	Roszyk et al.	4,512,769 A	4/1985	Kozam et al.
3,847,145 A	11/1974	Grossan	4,517,962 A	5/1985	Heckele
3,854,209 A	12/1974	Franklin et al.	4,531,912 A	7/1985	Schuss et al.
3,863,628 A	2/1975	Vit	4,531,913 A	7/1985	Taguchi
3,871,560 A	3/1975	Crippa	4,534,340 A	8/1985	Kerr et al.
3,874,506 A	4/1975	Hill et al.	4,552,130 A	11/1985	Kinoshita
3,911,796 A	10/1975	Hull et al.	4,561,214 A	12/1985	Inoue
3,912,125 A	10/1975	Acklin	D283,374 S	4/1986	Cheuk-Yiu
3,943,628 A	3/1976	Kronman et al.	4,585,415 A	4/1986	Hommann
3,959,883 A	6/1976	Walls et al.	4,591,777 A	5/1986	McCarty et al.
3,973,558 A	8/1976	Stouffer et al.	4,592,728 A	6/1986	Davis
3,977,084 A	8/1976	Sloan	4,602,906 A	7/1986	Grunenfelder
4,001,526 A	1/1977	Olson	4,607,627 A	8/1986	Leber et al.
4,004,302 A	1/1977	Hori	4,613,074 A	9/1986	Schulze
4,007,739 A	2/1977	Bron et al.	4,619,009 A	10/1986	Rosenstatter
4,013,227 A	3/1977	Herrera	4,619,612 A	10/1986	Weber et al.
4,022,114 A	5/1977	Hansen, III	4,629,425 A	12/1986	Detsch
4,052,002 A	10/1977	Stouffer et al.	4,636,198 A	1/1987	Stade
D246,667 S	12/1977	Mackay et al.	4,642,037 A	2/1987	Fritchman
D246,668 S	12/1977	Mackay et al.	4,644,937 A	2/1987	Hommann
4,060,870 A	12/1977	Cannarella	4,645,488 A	2/1987	Matukas
4,075,761 A	2/1978	Behne et al.	4,647,831 A	3/1987	O'Malley et al.
4,078,558 A	3/1978	Woog et al.	4,648,838 A	3/1987	Schlachter
4,094,311 A	6/1978	Hudson	4,650,475 A	3/1987	Smith et al.
4,108,167 A	8/1978	Hickman et al.	4,655,198 A	4/1987	Hommann
4,108,178 A	8/1978	Betush	4,669,453 A	6/1987	Atkinson et al.
4,109,650 A	8/1978	Peclard	4,672,953 A	6/1987	DiVito
4,122,845 A	10/1978	Stouffer et al.	4,673,396 A	6/1987	Urbaniak
4,133,971 A	1/1979	Boyd et al.	D291,354 S	8/1987	Camens
4,135,501 A	1/1979	Leunissan	4,716,352 A	12/1987	Hum et al.
4,141,352 A	2/1979	Ebner et al.	4,749,340 A	6/1988	Ikeda et al.
4,144,646 A	3/1979	Takemoto et al.	4,770,632 A	9/1988	Ryder et al.
4,149,315 A	4/1979	Page, Jr. et al.	D298,565 S	11/1988	Kohler, Jr. et al.
4,154,375 A	5/1979	Bippus	4,783,321 A	11/1988	Spence
4,160,383 A	7/1979	Rauschenberger	4,787,845 A	11/1988	Valentine
4,171,572 A	10/1979	Nash	4,787,847 A	11/1988	Martin et al.
4,182,038 A	1/1980	Fleer	4,798,292 A	1/1989	Hauze
4,200,235 A	4/1980	Monschke	4,803,974 A	2/1989	Powell
4,201,200 A	5/1980	Hubner	4,804,364 A	2/1989	Dieras et al.
4,210,380 A	7/1980	Brzostek	4,810,148 A	3/1989	Aisa et al.
4,215,476 A	8/1980	Armstrong	4,818,229 A	4/1989	Vasile
4,219,618 A	8/1980	Leonard	4,820,152 A	4/1989	Warrin et al.
4,227,878 A	10/1980	Lohn	4,821,923 A	4/1989	Skorka
4,229,634 A	10/1980	Hickman et al.	4,824,368 A	4/1989	Hickman
4,236,889 A	12/1980	Wright	4,826,431 A	5/1989	Fujimura et al.
D258,097 S	2/1981	Wistrand	4,827,551 A	5/1989	Maser et al.
4,248,589 A	2/1981	Lewis	4,832,683 A	5/1989	Idemoto et al.
4,249,899 A	2/1981	Davis	4,854,869 A	8/1989	Lawhorn
4,257,458 A	3/1981	Kondo et al.	4,861,340 A	8/1989	Smith et al.
4,262,799 A	4/1981	Perrett	4,862,876 A	9/1989	Lih-Sheng
4,266,934 A	5/1981	Pernot	4,864,918 A	9/1989	Martin
4,276,023 A	6/1981	Phillips et al.	4,869,720 A	9/1989	Chernack
4,276,880 A	7/1981	Malmin	4,880,382 A	11/1989	Moret et al.
4,302,186 A	11/1981	Cammack et al.	4,886,452 A	12/1989	Lohn
4,303,064 A	12/1981	Bufa	4,900,252 A	2/1990	Liefke et al.

US D832,418 S

4,902,225 A	2/1990	Lohn	5,269,684 A	12/1993	Fischer
4,903,687 A	2/1990	Lih-Sheng	5,281,137 A	1/1994	Jousson
4,906,187 A	3/1990	Amadera	5,281,139 A	1/1994	Frank et al.
4,907,744 A	3/1990	Jousson	5,282,745 A	2/1994	Wiltrout et al.
4,915,304 A	4/1990	Campani	5,286,192 A	2/1994	Dixon
4,925,450 A	5/1990	Imonti et al.	5,286,201 A	2/1994	Yu
4,928,675 A	5/1990	Thornton	5,295,832 A	3/1994	Evans
4,930,660 A	6/1990	Porteous	5,297,962 A	3/1994	O'Connor et al.
4,941,459 A	7/1990	Mathur	D346,212 S	4/1994	Hosl
4,950,159 A	8/1990	Hansen	5,301,381 A	4/1994	Klupt
4,958,629 A	9/1990	Peace et al.	5,302,123 A	4/1994	Bechard
4,958,751 A	9/1990	Curtis et al.	5,317,691 A	5/1994	Traeger
4,959,199 A	9/1990	Brewer	5,321,865 A	6/1994	Kaerer
4,961,698 A	10/1990	Vlock	5,323,770 A	6/1994	Ito et al.
4,966,551 A	10/1990	Betush	5,331,704 A	7/1994	Rosen et al.
4,969,874 A	11/1990	Michel et al.	5,344,317 A	9/1994	Pacher et al.
4,973,246 A	11/1990	Black	5,346,677 A	9/1994	Risk
4,973,247 A	11/1990	Varnes et al.	5,349,896 A	9/1994	Delaney
4,973,250 A	11/1990	Milman	D351,892 S	10/1994	Wolf et al.
4,975,054 A	12/1990	Esrock	5,360,338 A	11/1994	Waggoner
4,979,503 A	12/1990	Chernack	5,368,548 A	11/1994	Jousson
4,979,504 A	12/1990	Mills	5,370,534 A	12/1994	Wolf et al.
4,989,590 A *	2/1991	Baum A61C 1/0092 137/493.3	D354,168 S	1/1995	Hartwein
			D354,559 S	1/1995	Knute
4,998,880 A	3/1991	Nerli	5,378,149 A	1/1995	Stropko
5,013,241 A	5/1991	Von Gutfeld et al.	5,380,201 A	1/1995	Kawata
5,014,884 A	5/1991	Wunsch	D356,864 S	3/1995	Woog
5,019,054 A	5/1991	Clement et al.	5,399,089 A	3/1995	Eichman et al.
5,027,798 A	7/1991	Primiano	D358,883 S	5/1995	Vos
5,029,576 A	7/1991	Evans, Sr.	5,456,672 A	10/1995	Diederich et al.
5,033,617 A	7/1991	Hartwein et al.	5,465,445 A	11/1995	Yeh
5,033,961 A	7/1991	Kandler et al.	5,467,495 A	11/1995	Boland et al.
D318,918 S	8/1991	Hartwein	5,468,148 A	11/1995	Ricks
5,046,486 A	9/1991	Grulke et al.	5,470,305 A	11/1995	Arnett et al.
5,049,071 A	9/1991	Davis et al.	5,474,450 A	12/1995	Chronister
5,060,825 A	10/1991	Palmer et al.	5,474,451 A	12/1995	Dalrymple et al.
5,061,180 A	10/1991	Wiele	5,476,379 A	12/1995	Disel
5,062,795 A	11/1991	Woog	5,484,281 A	1/1996	Renow et al.
5,064,168 A	11/1991	Raines et al.	5,487,877 A	1/1996	Choi
D322,314 S	12/1991	Ohbayashi	5,490,779 A	2/1996	Malmin
5,071,346 A	12/1991	Domaas	5,505,916 A	4/1996	Berry, Jr.
5,082,115 A	1/1992	Hutcheson	D369,656 S	5/1996	Vos
5,082,443 A	1/1992	Lohn	D370,125 S	5/1996	Craft et al.
5,085,317 A	2/1992	Jensen et al.	5,525,058 A	6/1996	Gallant et al.
5,086,756 A	2/1992	Powell	5,526,841 A	6/1996	Detsch et al.
5,095,893 A	3/1992	Rawden, Jr.	5,540,587 A	7/1996	Malmin
5,098,291 A	3/1992	Curtis et al.	5,547,374 A	8/1996	Coleman
5,098,676 A	3/1992	Brooks, Jr.	D373,631 S	9/1996	Maeda et al.
5,100,319 A	3/1992	Baum	5,554,014 A	9/1996	Becker
5,117,871 A	6/1992	Gardner et al.	5,554,025 A	9/1996	Kinsel
5,125,835 A	6/1992	Young	5,556,001 A	9/1996	Weissman et al.
5,127,831 A	7/1992	Bab	5,564,629 A	10/1996	Weissman et al.
5,142,723 A	9/1992	Lustig et al.	D376,893 S	12/1996	Gornet
5,150,841 A	9/1992	Silvenis et al.	D377,091 S	12/1996	Scott, Sr.
5,172,810 A	12/1992	Brewer	5,613,259 A	3/1997	Craft et al.
5,173,273 A	12/1992	Brewer	5,616,028 A	4/1997	Hafele et al.
5,183,035 A	2/1993	Weir	5,626,472 A	5/1997	Pennetta
5,197,458 A	3/1993	Ito et al.	5,634,791 A	6/1997	Matsuura et al.
5,197,460 A	3/1993	Ito et al.	5,636,987 A	6/1997	Serfaty
5,199,871 A	4/1993	Young	5,640,735 A	6/1997	Manning
5,203,697 A	4/1993	Malmin	D382,407 S	8/1997	Craft et al.
5,203,769 A	4/1993	Clement et al.	5,653,591 A	8/1997	Loge
5,204,004 A	4/1993	Johnston et al.	5,659,995 A	8/1997	Hoffman
5,208,933 A	5/1993	Lustig et al.	5,667,483 A	9/1997	Santos
5,215,193 A	6/1993	Dennis	D386,576 S	11/1997	Wang et al.
5,218,956 A	6/1993	Handler et al.	5,683,192 A	11/1997	Kilfoil
5,220,914 A	6/1993	Thompson	5,685,829 A	11/1997	Allen
5,228,646 A	7/1993	Raines	5,685,851 A	11/1997	Murphy et al.
5,230,624 A	7/1993	Wolf et al.	5,697,784 A	12/1997	Hafele et al.
5,232,687 A	8/1993	Geimer	D388,612 S	1/1998	Stutzer et al.
5,235,968 A	8/1993	Woog	D388,613 S	1/1998	Stutzer et al.
5,241,714 A	9/1993	Barry	D389,091 S	1/1998	Dickinson
5,246,367 A	9/1993	Ito et al.	5,709,545 A	1/1998	Johnston et al.
5,252,064 A	10/1993	Baum et al.	D390,934 S	2/1998	McKeone
D341,200 S	11/1993	Yoshimoto	5,716,007 A	2/1998	Nottingham et al.
5,257,933 A	11/1993	Jousson	5,718,668 A	2/1998	Arnett et al.
5,261,448 A	11/1993	Furuya et al.	5,746,595 A	5/1998	Ford
D341,943 S	12/1993	Si-Hoe	5,749,726 A	5/1998	Kinsel
5,267,586 A	12/1993	Jankavaara	5,759,502 A	6/1998	Spencer et al.

US D832,418 S

Page 4

5,779,471 A	7/1998	Tseng et al.	6,663,386 B1	12/2003	Moelsgaard
5,779,654 A	7/1998	Foley et al.	6,669,059 B2	12/2003	Mehta
5,795,153 A	8/1998	Rechmann	D484,971 S	1/2004	Hartwein
5,796,325 A	8/1998	Lundell et al.	6,681,418 B1	1/2004	Bierend
5,833,065 A	11/1998	Burgess	D486,573 S	2/2004	Callaghan et al.
5,836,030 A	11/1998	Hazeu et al.	6,689,078 B1	2/2004	Rehkemper et al.
D402,744 S	12/1998	Zuege	6,699,208 B2	3/2004	Bachman et al.
5,851,079 A	12/1998	Horstman et al.	6,719,561 B2	4/2004	Gugel et al.
D403,511 S	1/1999	Serbinski	D489,183 S	5/2004	Akahori et al.
D406,334 S	3/1999	Rosenthal et al.	6,739,782 B1	5/2004	Rehkemper et al.
5,876,201 A	3/1999	Wilson et al.	6,740,053 B2	5/2004	Kaplowitz
D408,511 S	4/1999	Allen et al.	D490,899 S	6/2004	Gagnon
5,901,397 A	5/1999	Häfele et al.	D491,728 S	6/2004	Jimenez
5,934,902 A	8/1999	Abahusayn	D492,996 S	7/2004	Rehkemper et al.
D413,975 S	9/1999	Maeda	6,761,324 B2	7/2004	Chang
D416,999 S	11/1999	Miyamoto	6,766,549 B2	7/2004	Klupt
D417,082 S	11/1999	Classen et al.	D495,142 S	8/2004	Berde
5,993,402 A	11/1999	Sauer et al.	D495,143 S	8/2004	Berde
6,030,215 A	2/2000	Ellion et al.	6,779,216 B2	8/2004	Davies et al.
6,038,960 A	3/2000	Fukushima et al.	6,783,004 B1	8/2004	Rinner
6,039,180 A	3/2000	Grant	6,783,505 B1	8/2004	Lai
6,047,429 A	4/2000	Wu	6,796,796 B2	9/2004	Segal
D424,181 S	5/2000	Caplow	6,808,331 B2	10/2004	Hall et al.
D425,615 S	5/2000	Bachman et al.	D498,643 S	11/2004	Pryor
D425,981 S	5/2000	Bachman et al.	6,814,259 B1	11/2004	Foster et al.
6,056,548 A	5/2000	Neuberger et al.	D499,885 S	12/2004	Xi
6,056,710 A	5/2000	Bachman et al.	6,835,181 B2	12/2004	Hippensteel
D426,633 S	6/2000	Bachman et al.	D500,599 S	1/2005	Callaghan
6,089,865 A	7/2000	Edgar	6,836,917 B2	1/2005	Blaustein et al.
6,116,866 A	9/2000	Tomita et al.	6,837,708 B2	1/2005	Chen et al.
6,120,755 A	9/2000	Jacobs	6,884,069 B2	4/2005	Goldman
6,124,699 A	9/2000	Suzuki et al.	6,902,337 B1	6/2005	Kuo
D434,500 S	11/2000	Pollock et al.	6,907,879 B2	6/2005	Drinan et al.
6,159,006 A	12/2000	Cook et al.	D509,585 S	9/2005	Kling et al.
6,164,967 A	12/2000	Sale et al.	D513,638 S	1/2006	Pan
D435,905 S	1/2001	Bachman et al.	D515,215 S	2/2006	Wang
D437,049 S	1/2001	Hartwein	D522,652 S	6/2006	Massey
6,193,512 B1	2/2001	Wallace	7,080,980 B2	7/2006	Klupt
6,193,932 B1	2/2001	Wu et al.	D529,661 S	10/2006	Schmidt
6,199,239 B1	3/2001	Dickerson	D530,010 S	10/2006	Luetzgen et al.
6,200,134 B1	3/2001	Kovac	7,117,555 B2	10/2006	Fattori et al.
D439,781 S	4/2001	Spore	D532,570 S	11/2006	Vizcarra
6,217,835 B1	4/2001	Riley et al.	7,131,838 B2	11/2006	Suzuki et al.
D441,861 S	5/2001	Hafliger	D533,720 S	12/2006	Vu
6,233,773 B1	5/2001	Karge et al.	7,147,468 B2	12/2006	Snyder et al.
6,234,205 B1	5/2001	D'Amelio et al.	D538,474 S	3/2007	Sheppard et al.
6,237,178 B1	5/2001	Krammer et al.	D548,334 S	8/2007	Izumi
6,247,929 B1	6/2001	Bachman et al.	D550,097 S	9/2007	Lepoitevin
6,280,190 B1	8/2001	Hoffman	D553,980 S	10/2007	VerWeyst
D448,236 S	9/2001	Murray	7,276,035 B2	10/2007	Lu
6,293,792 B1	9/2001	Hanson	7,314,456 B2	1/2008	Shaw
D449,884 S	10/2001	Tobin et al.	D563,674 S	3/2008	Beedham
6,299,419 B1	10/2001	Hunklinger	D565,175 S	3/2008	Boyd et al.
D453,453 S	2/2002	Lun	7,344,510 B1	3/2008	Yande
D455,201 S	4/2002	Jones	D565,713 S	4/2008	Gao
D455,203 S	4/2002	Jones	7,367,803 B2	5/2008	Egeresi
6,363,565 B1	4/2002	Paffrath	D574,952 S	8/2008	Boyd et al.
D457,949 S	5/2002	Krug	7,414,337 B2	8/2008	Wilkinson et al.
D464,799 S	10/2002	Crossman et al.	D577,198 S	9/2008	Jimenez
6,468,482 B1	10/2002	Frieze et al.	D577,814 S	9/2008	Seki et al.
6,475,173 B1	11/2002	Bachman et al.	D581,279 S	11/2008	Oates
6,485,451 B1	11/2002	Roberts et al.	7,455,521 B2	11/2008	Fishburne, Jr.
6,497,375 B1	12/2002	Srinath et al.	7,469,440 B2	12/2008	Boland et al.
6,497,572 B2	12/2002	Hood et al.	D585,132 S	1/2009	Pukall
D468,422 S	1/2003	McCurrach	D588,262 S	3/2009	Pukall
6,502,584 B1	1/2003	Fordham	7,500,584 B2	3/2009	Schutz
D470,660 S	2/2003	Schaber	D590,492 S	4/2009	Powell
6,532,837 B1	3/2003	Magussen, Jr.	D592,748 S	5/2009	Boulton
6,558,344 B2	5/2003	McKinnon et al.	D595,136 S	6/2009	Canamasas Puigbo
6,561,808 B2	5/2003	Neuberger et al.	D601,694 S	10/2009	Rocklin
D475,346 S	6/2003	McCurrach et al.	D601,697 S	10/2009	Sobeich et al.
D476,743 S	7/2003	D'Silva	D603,708 S	11/2009	Handy
6,589,477 B1	7/2003	Frieze et al.	D608,430 S	1/2010	Slothower
6,602,071 B1	8/2003	Ellion et al.	7,670,141 B2	3/2010	Thomas et al.
6,632,091 B1	10/2003	Cise et al.	7,677,888 B1	3/2010	Halm
D482,451 S	11/2003	Page et al.	D613,550 S	4/2010	Picozza et al.
6,640,999 B2	11/2003	Peterson	D621,949 S	8/2010	Seki et al.
6,647,577 B2	11/2003	Tam	D622,928 S	9/2010	Griebel
6,659,674 B2	12/2003	Carlucci et al.	D623,376 S	9/2010	Griebel

US D832,418 S

D625,105 S	10/2010	Winkler	2002/0119415 A1	8/2002	Bailey
D625,406 S	10/2010	Seki et al.	2002/0152565 A1	10/2002	Klupt
7,814,585 B1	10/2010	Reich	2003/0060743 A1	3/2003	Chang
D626,647 S	11/2010	Amborn	2003/0098249 A1	5/2003	Rollock
D629,884 S	12/2010	Stephens	2003/0162146 A1	8/2003	Shortt et al.
7,857,623 B2	12/2010	Grez	2003/0204155 A1	10/2003	Egeresi
7,862,536 B2	1/2011	Chen et al.	2003/0213075 A1	11/2003	Hui et al.
7,959,597 B2	6/2011	Baker et al.	2004/0045107 A1	3/2004	Egeresi
D640,872 S	7/2011	Nanda	2004/0076921 A1	4/2004	Gofman et al.
D648,539 S	11/2011	Wai	2004/0122377 A1	6/2004	Fischer et al.
D648,941 S	11/2011	Leung	2004/0126730 A1	7/2004	Panagotacos
D651,409 S	1/2012	Papenfu	2004/0180569 A1	10/2004	Chiou
D651,805 S	1/2012	Hay	2004/0209222 A1	10/2004	Snyder
D653,340 S	1/2012	Goerge et al.	2005/0049620 A1	3/2005	Chang
8,113,832 B2	2/2012	Snyder et al.	2005/0064371 A1	3/2005	Soukos et al.
D655,380 S	3/2012	Taylor	2005/0101894 A1	5/2005	Hippensteel
D658,381 S	5/2012	Gebski	2005/0102773 A1	5/2005	Obermann et al.
D658,538 S	5/2012	Korzeniowski	2005/0144745 A1	7/2005	Russell
8,220,726 B2	7/2012	Qiu et al.	2005/0177079 A1	8/2005	Pan
D666,912 S	9/2012	Kawai	2005/0271531 A1	12/2005	Brown et al.
8,256,979 B2	9/2012	Hilscher et al.	2006/0008373 A1	1/2006	Schutz
D668,339 S	10/2012	Luoto	2006/0010624 A1	1/2006	Cleland
D669,169 S	10/2012	Washington et al.	2006/0026784 A1	2/2006	Moskovich et al.
8,297,534 B2	10/2012	Li et al.	2006/0057539 A1	3/2006	Sodo
D670,373 S	11/2012	Taylor et al.	2006/0078844 A1	4/2006	Goldman et al.
D670,958 S	11/2012	Picozza et al.	2006/0079818 A1	4/2006	Yande
D671,637 S	11/2012	Gebski et al.	2006/0207052 A1	9/2006	Tran
D672,018 S	12/2012	Bucher	2007/0082316 A1	4/2007	Zhadanov et al.
8,366,024 B2	2/2013	Leber et al.	2007/0082317 A1	4/2007	Chuang
8,403,577 B2	3/2013	Khoshnevis	2007/0113360 A1	5/2007	Tsai
8,403,665 B2	3/2013	Thomas et al.	2007/0202459 A1	8/2007	Boyd et al.
8,408,483 B2	4/2013	Boyd et al.	2007/0203439 A1	8/2007	Boyd et al.
8,418,300 B2	4/2013	Miller et al.	2007/0254260 A1	11/2007	Alden
D686,311 S	7/2013	Mori	2008/0189951 A1	8/2008	Molema et al.
D694,378 S	11/2013	Bates	2008/0213719 A1	9/2008	Giniger et al.
D694,398 S	11/2013	Taylor	2008/0253906 A1	10/2008	Strong
D700,343 S	2/2014	Liu	2009/0070949 A1	3/2009	Sagel et al.
D702,819 S	4/2014	Garland	2009/0071267 A1	3/2009	Mathus et al.
D702,821 S	4/2014	Garland	2009/0082706 A1	3/2009	Shaw
D707,350 S	6/2014	Woodard	2009/0124945 A1	5/2009	Reich et al.
D709,183 S	7/2014	Kemlein	2009/0139351 A1	6/2009	Reichmuth
D714,929 S	10/2014	Kim et al.	2009/0163839 A1	6/2009	Alexander
D714,930 S	10/2014	Kim et al.	2009/0188780 A1	7/2009	Watanabe
D717,412 S	11/2014	Bucher	2009/0281454 A1	11/2009	Baker et al.
D717,427 S	11/2014	Kim	2010/0010524 A1	1/2010	Barrington
D717,547 S	11/2014	Adriaenssen	2010/0015566 A1	1/2010	Shaw
D718,855 S	12/2014	Kim et al.	2010/0049177 A1	2/2010	Boone, III et al.
D719,737 S	12/2014	Adriaenssen	2010/0190132 A1	7/2010	Taylor et al.
D723,387 S	3/2015	Fath	2010/0239998 A1	9/2010	Snyder et al.
D725,770 S *	3/2015	Kim D24/111	2010/0261134 A1	10/2010	Boyd et al.
D731,640 S	6/2015	Kim et al.	2010/0261137 A1	10/2010	Boyd et al.
D735,305 S	7/2015	Obara	2010/0326536 A1	12/2010	Nan
D740,936 S *	10/2015	Kim D24/111	2010/0330527 A1	12/2010	Boyd et al.
D745,329 S	12/2015	Ong	2011/0027749 A1	2/2011	Syed
D745,423 S	12/2015	Khattak	2011/0076090 A1	3/2011	Wu et al.
D746,975 S	1/2016	Schenck	2011/0097683 A1	4/2011	Boyd et al.
D747,464 S	1/2016	Taylor	2011/0139826 A1	6/2011	Hair et al.
D754,330 S	4/2016	Kim et al.	2011/0144588 A1	6/2011	Taylor et al.
D756,122 S	5/2016	Taylor	2011/0184341 A1	7/2011	Baker et al.
D764,051 S *	8/2016	Wang D24/111	2011/0307039 A1	12/2011	Cornell
D766,423 S	9/2016	Kim et al.	2012/0021374 A1	1/2012	Cacka et al.
D772,396 S	11/2016	Kim et al.	2012/0045730 A1	2/2012	Snyder et al.
D772,397 S	11/2016	Kim et al.	2012/0064480 A1	3/2012	Hegemann
D773,822 S	12/2016	Sikora	2012/0077145 A1	3/2012	Tsurukawa
D774,651 S	12/2016	Kaib	2012/0141952 A1	6/2012	Snyder et al.
D776,253 S	1/2017	Li	2012/0179118 A1	7/2012	Hair
D782,326 S	3/2017	Fath	2012/0189976 A1	7/2012	McDonough et al.
D782,656 S	3/2017	Au	2012/0266396 A1	10/2012	Leung
D782,657 S	3/2017	Williams	2012/0277663 A1	11/2012	Millman et al.
D786,422 S	5/2017	Au	2012/0277677 A1	11/2012	Taylor et al.
9,642,677 B2	5/2017	Luetttgen et al.	2012/0277678 A1	11/2012	Taylor et al.
D788,907 S *	6/2017	Kim D24/111	2012/0279002 A1	11/2012	Sokol et al.
D798,059 S	7/2017	McGarry	2012/0295220 A1	11/2012	Thomas et al.
D798,440 S *	9/2017	Kim D24/111	2013/0089832 A1	4/2013	Lee
D799,217 S	10/2017	Massee	2013/0295520 A1	11/2013	Hsieh
D802,119 S	11/2017	Kim	2014/0106296 A1	4/2014	Woodard et al.
D809,650 S	2/2018	Kim	2014/0193774 A1	7/2014	Snyder et al.
2002/0090252 A1	7/2002	Hall et al.	2014/0259474 A1	9/2014	Sokol et al.
2002/0108193 A1	8/2002	Gruber	2014/0272769 A1	9/2014	Luetttgen et al.

2014/0272782	A1	9/2014	Luetzgen et al.
2014/0352088	A1	12/2014	Wu
2015/0004559	A1	1/2015	Luetzgen et al.
2015/0147717	A1	5/2015	Taylor et al.
2015/0173850	A1*	6/2015	Garrigues A61C 1/0092 433/80
2015/0182319	A1	7/2015	Wagner et al.
2016/0100921	A1	4/2016	Ungar
2016/0151133	A1	6/2016	Luetzgen et al.
2017/0049530	A1	2/2017	Cacka
2017/0239132	A1	8/2017	Luetzgen et al.

FOREIGN PATENT DOCUMENTS

CA	851479	9/1970
CH	655237	4/1986
CN	204049908	12/2014
DE	1466963	5/1969
DE	2019003	11/1971
DE	2409752	9/1975
DE	2545936	4/1977
DE	2714876	10/1978
DE	2910982	2/1980
DE	3346651	7/1985
EP	0023672	7/1980
EP	0515983	2/1992
EP	1825827	8/2007
FR	2556954	6/1985
FR	2654627	5/1991
GB	838564	6/1960
GB	1182031	2/1970
GB	2018605	10/1979
JP	2-134150	5/1990
JP	2009-39455	2/2009
KR	20120126265	11/2012
WO	WO95/016404	6/1995
WO	WO01/10327	2/2001
WO	WO04/021958	3/2004
WO	WO04/039205	5/2004
WO	WO2004/060259	7/2004
WO	WO2004/062518	7/2004
WO	WO2008/070730	6/2008
WO	WO2008/157585	12/2008
WO	WO2013/124691	8/2013

OTHER PUBLICATIONS

US RE27,274, 01/1972, Mattingly (withdrawn)

Waterpik Classic Professional Water Flosser, WP-72, posted at amazon.com, earliest date reviewed on Mar. 5, 2016, [online], acquired on Feb. 23, 2018. Available from Internet, <URL: https://www.amazon.com/Waterpik-Classic-Professional-Flosser-WP-72/dp/B00HFQQ0U6/ref=cm_cr_arp_d_product_top?ie=UTF8> (Year: 2016).*

AliExpress. Date reviewed: Jan. 12, 2017. <<https://www.aliexpress.com/item/Cordless-Water-Floss-Portable-Oral-Irrigator-Dental-Water-Flosser-Waterpic-Whatepick-Dental-Water-Pic-Whater-Pick/32769416341.html?spm=2114.40010308.4.75.Owuzfj>>.

The Right Tool, Electron Fusion Devices, Inc., 2 pages, at least as early as Feb. 1991.

Japanese Packaging, 2 pages, at least as early as Dec. 2002.

Japanese Instruction Brochure, 20 pages, at least as early as Dec. 2002.

Brochure: Woog International, "You have a 98% chance of getting gum disease. Unless you read this.", Lancaster, Pennsylvania, 5 pages, Feb. 1987.

Brochure: Woog International, "We put the control of home dental care back into the hands of the professional", Lancaster, Pennsylvania, 2 pages, Feb. 1987.

Brochure: Woog International, "Products at a Glance: Home Dental Care System" Woog Orajet, 3 pages, at least as early as Dec. 18, 1998.

Website: http://www.just4teeth.com/product/Panasonic/Panasonic_Portable_Irrigator.htm, 2 pages, at least as early as Jun. 20, 2003.

Website: http://www.videodirectstore.com/store/merchant.mv?Screen=PROD&Product_Code=EW1'..., 2 pages, at least as early as Jun. 20, 2003.

Website: <http://products.consumerguide.com/cp/family/review/index.cfm/id/18742>, 2 pages, at least as early as Jun. 20, 2003.

Website: <http://www.racekarteng.com/images/walbroparts.gif> and <http://www.muller.net/mullermachine/docs/walbro1.html>, 4 pages, at least as early as Jun. 20, 2003.

European Search Report, EPO Application No. 07250799.9, dated Jul. 5, 2007.

European Search Report, EPO Application No. 07252693.2, 14 pages, dated Apr. 28, 2008.

European Examination Report, EPO Application No. 07250799.9, dated Feb. 5, 2009.

International Search Report, Application No. PCT/US2010/028180, 2 pages, dated May 18, 2010.

International Search Report, PCT/US2010/060800, 2 pages, dated Feb. 11, 2011.

International Search Report, PCT/US2011/052795, 10 pages, dated Jan. 17, 2012.

Waterpik SinuSense Website: <http://www.insightsbyapril.com/2012/03/waterpik-natural-remedy-for-sinus.html>, 8 pages, retrieved on May 31, 2012.

Website: <https://www.waterpik.com/about-us/>, 3 pages.

Waterpik WP350W Oral Irrigator. Dentist.net. Copyright date 2013. Date accessed: Mar. 30, 2017, 2 pages.

iPik Portable Oral Irrigator. AliExpress. Date reviewed: Oct. 5, 2016. https://www.aliexpress.com/...e-Oral-Care-Product-Nasal-Irrigator-Tooth-Flosser-Water/1525541997.html?aff_platform=aaf&cpt=1490913714609&sk=yfAeyJa&aff_trace_key=c5a300c4f02e46d08c042f5292e1762f-1490913714609-07517-yfAeyJa, 18 pages.

Brite Leaf Professional Portable 2-in-1 Nasal Sinus & Oral Irrigator. Brite Leaf. Copyright date 2012, <http://www.briteleafs.com/product6.html>, 1 page.

Suvo. "Helical Gears vs Spur Gears—Advantages and Disadvantages Compared." BrightHub Engineering, Aug. 18, 2010, www.brighthubengineering.com/manufacturing-technology/33535-helical-gears-vs-spur-gears/, 7 pages.

Waterpik ADA Accepted WP-663, posted at amazon.com, earliest date reviewed on Feb. 6, 2014, [online], acquired on Feb. 12, 2018. Available from Internet, <URL: https://www.amazon.com/Waterpik-Accepted-WP-663-Aquarius-Flosser/dp/B072JFVXSY/ref=cm_cr_arp_d_product_top?ie=UTF8&th=1> (Year: 2014).

Waterpik Complete Care 5.0 Toothbrush, posted at amazon.com, earliest date reviewed on Mar. 14, 2016, [online], acquired on Feb. 23, 2018. Available from Internet, <URL: https://www.amazon.com/Waterpik-Complete-Toothbrush-Water-Flosser/dp/B01CRZ939Y/ref=cm_cr_arp_d_product_top?ie=UTF8> (Year: 2016).

* cited by examiner

Primary Examiner — Marianne N Pandozzi
 Assistant Examiner — Aula Soroush
 (74) Attorney, Agent, or Firm — Dorsey & Whitney LLP

(57) CLAIM

We claim the ornamental design for an oral irrigator base, as shown and described.

DESCRIPTION

FIG. 1 is a front isometric view of a first embodiment of an oral irrigator base with a toothbrush, hose, reservoir, and lid shown for environment.

FIG. 2 is a front isometric view of the oral irrigator base of FIG. 1.

FIG. 3 is a front elevation view of the oral irrigator base of FIG. 2.

FIG. 4 is a rear elevation view of the oral irrigator base of FIG. 2.

FIG. 5 is a left side elevation view of the oral irrigator base of FIG. 2.

FIG. 6 is a right side elevation view of the oral irrigator base of FIG. 2.

FIG. 7 is a top plan view of the oral irrigator base of FIG. 2.

FIG. 8 is a bottom plan view of the oral irrigator base of FIG. 2.

FIG. 9 is a front isometric view of a second embodiment of an oral irrigator base.

FIG. 10 is a front elevation view of the oral irrigator base of FIG. 9.

FIG. 11 is a rear elevation view of the oral irrigator base of FIG. 9.

FIG. 12 is a left side elevation view of the oral irrigator base of FIG. 9.

FIG. 13 is a right side elevation view of the oral irrigator base of FIG. 9.

FIG. 14 is a top plan view of the oral irrigator base of FIG. 9; and,

FIG. 15 is a bottom plan view of the oral irrigator base of FIG. 9.

The broken line showing of the toothbrush, hose, reservoir, and lid in FIG. 1 illustrates environment and forms no part of the claimed design. All other broken lines illustrate portions of the oral irrigator base that form no part of the claimed design.

1 Claim, 15 Drawing Sheets

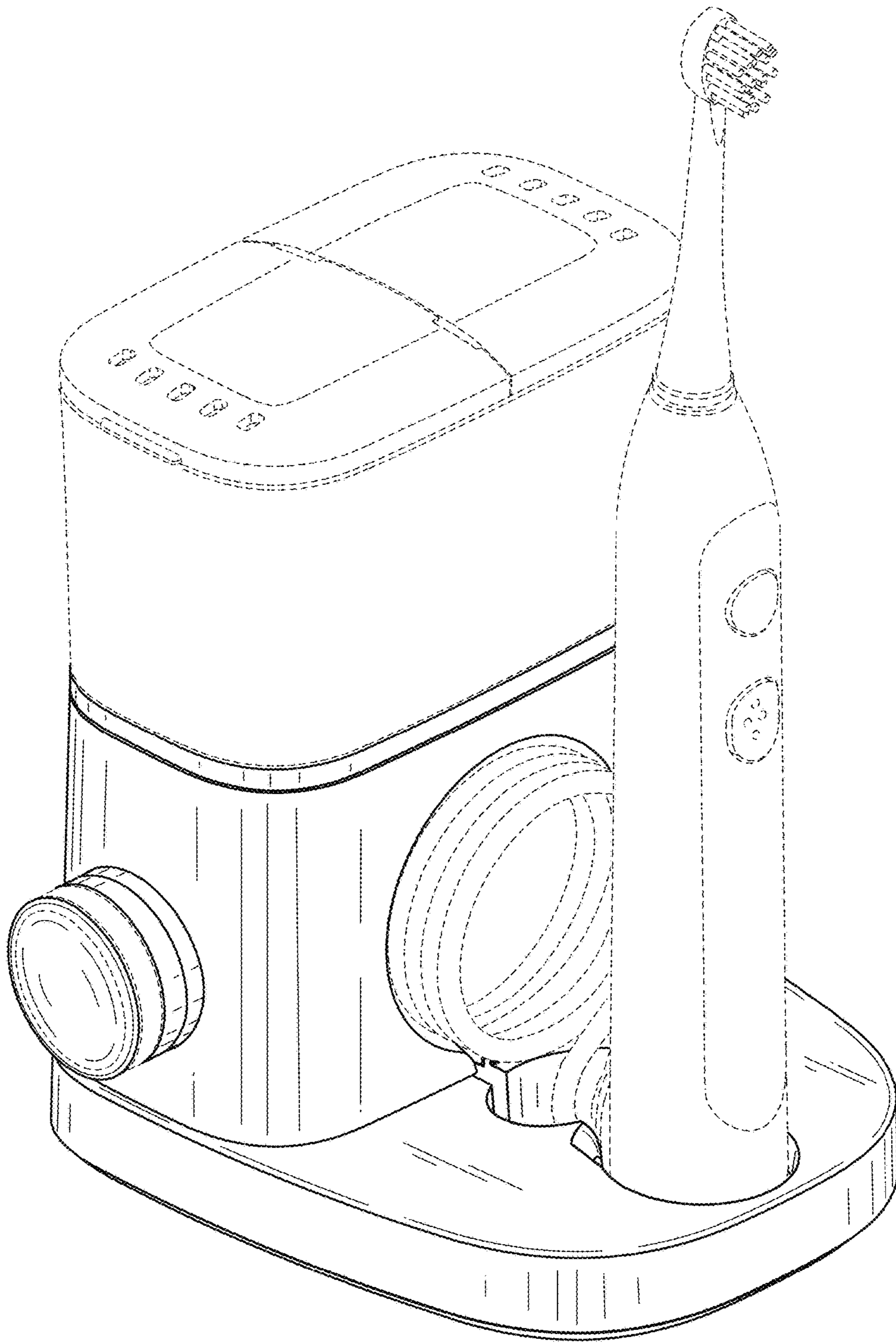

FIG. 1

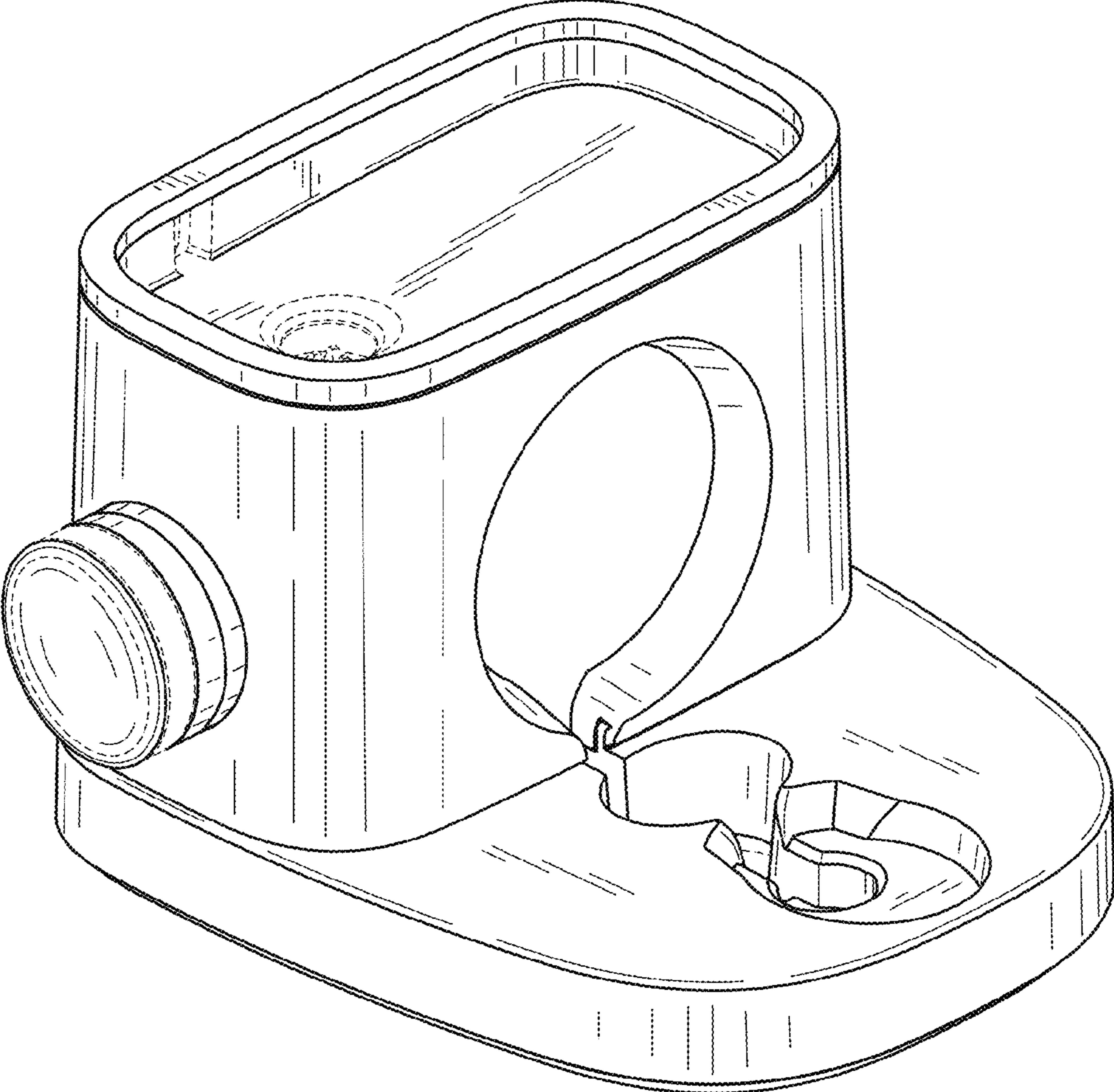

FIG. 2

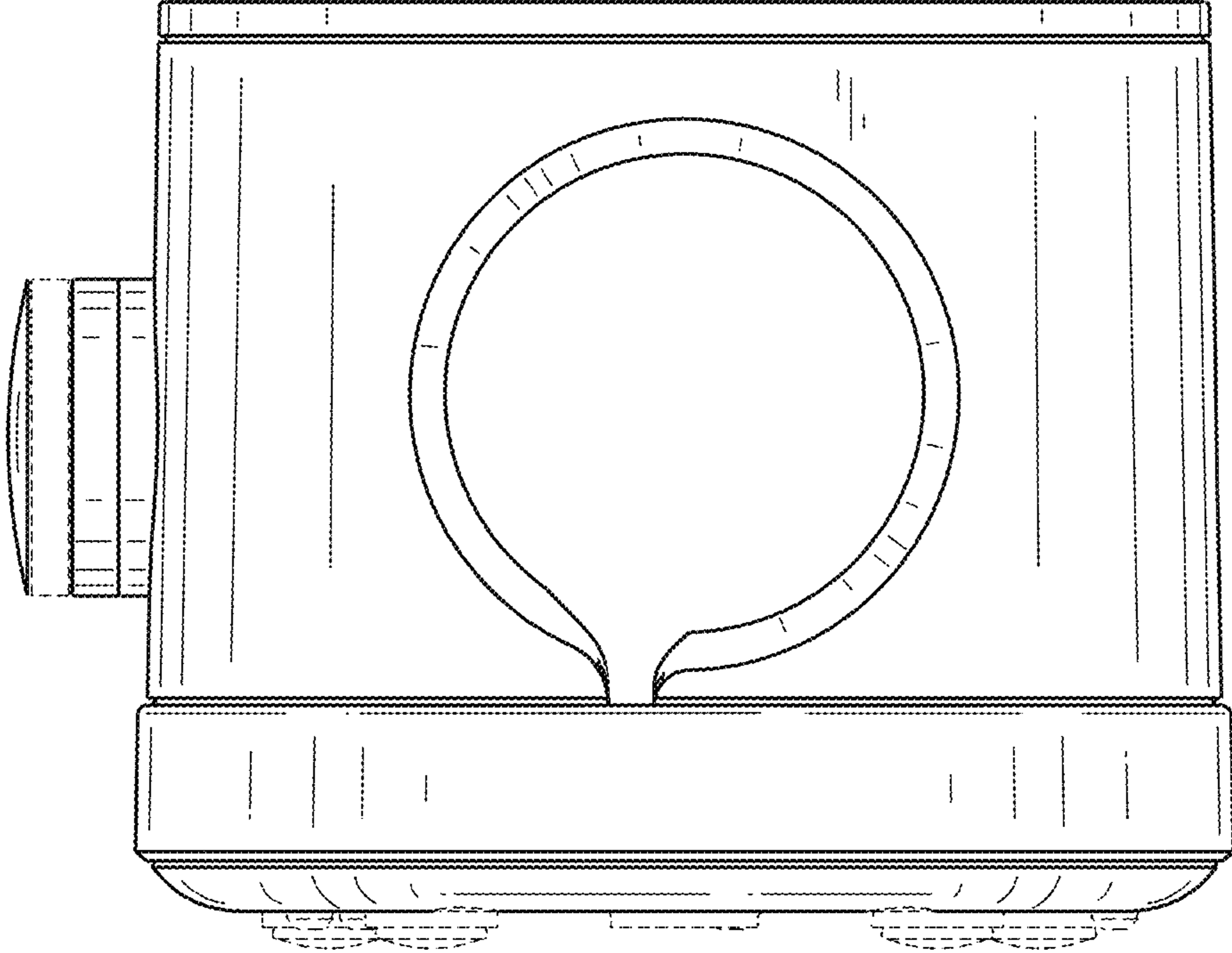

FIG. 3

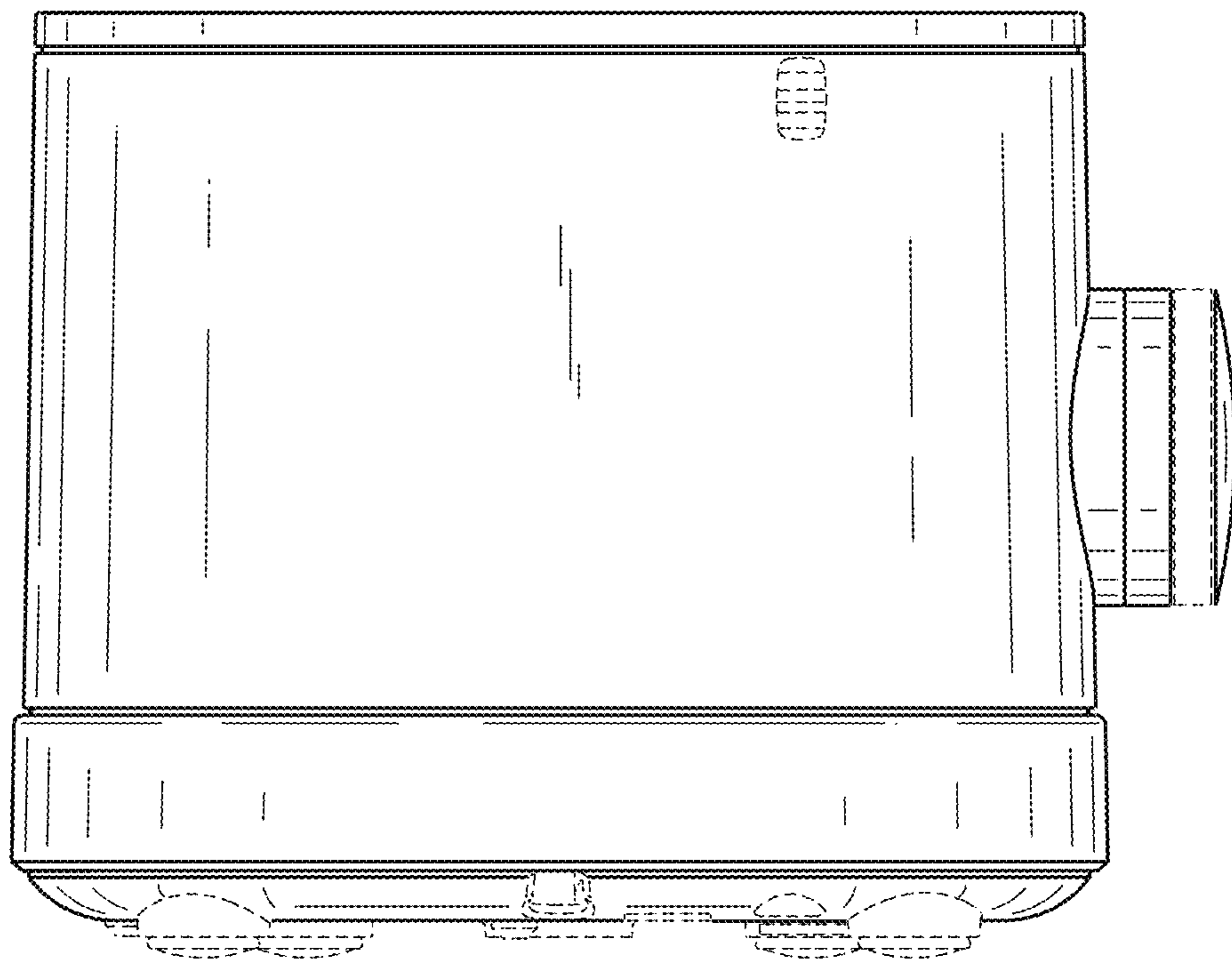

FIG. 4

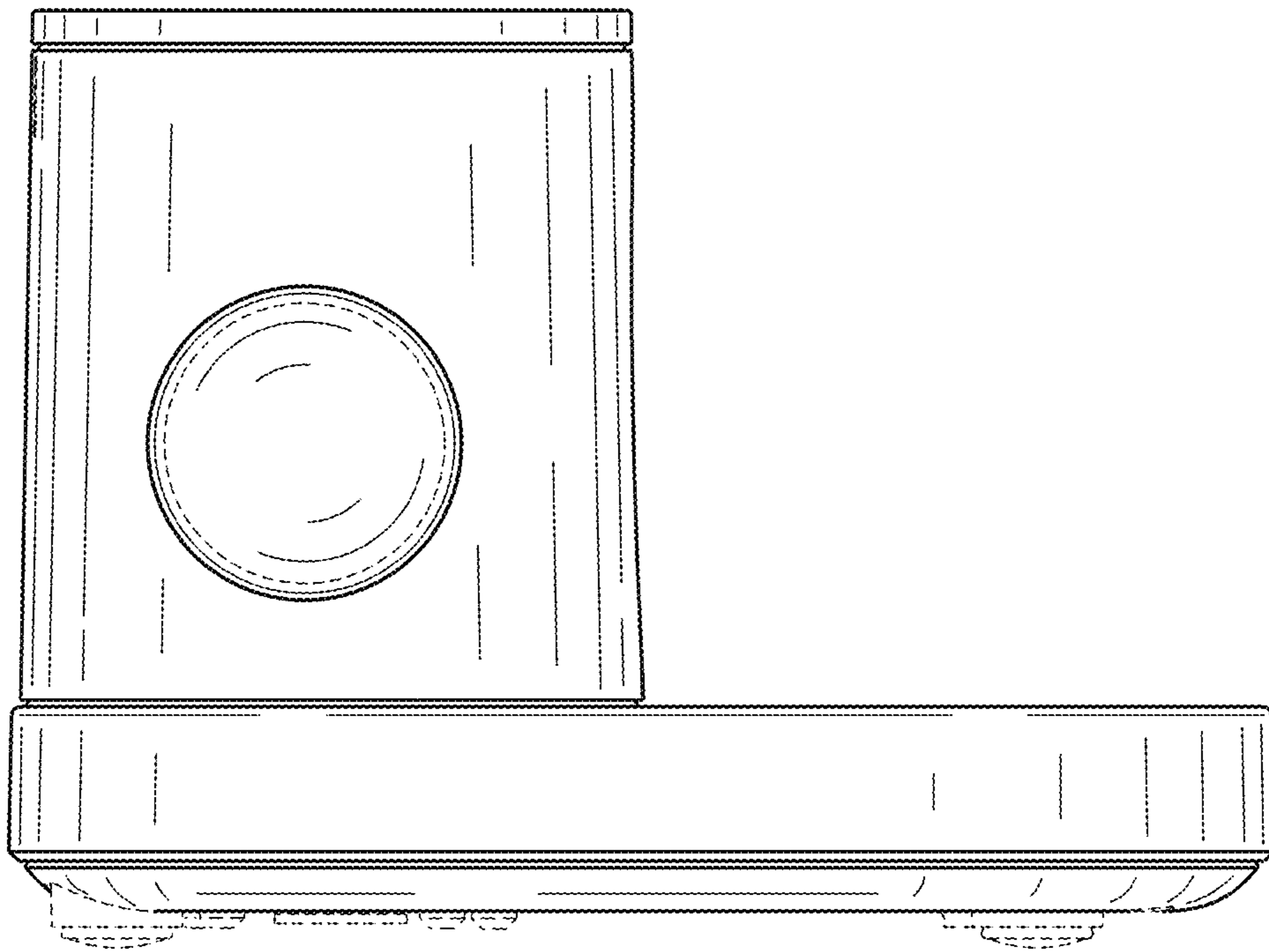

FIG. 5

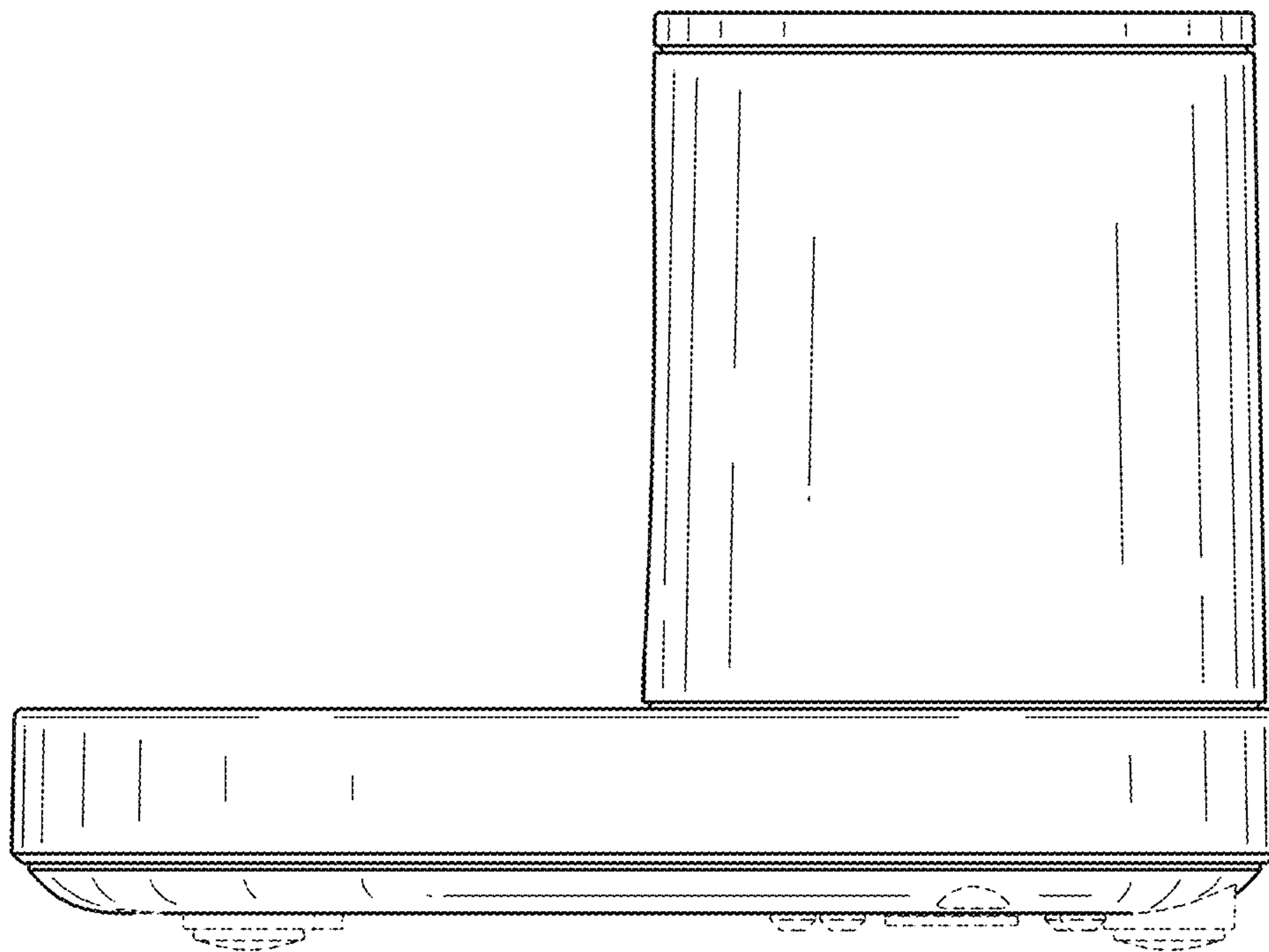

FIG. 6

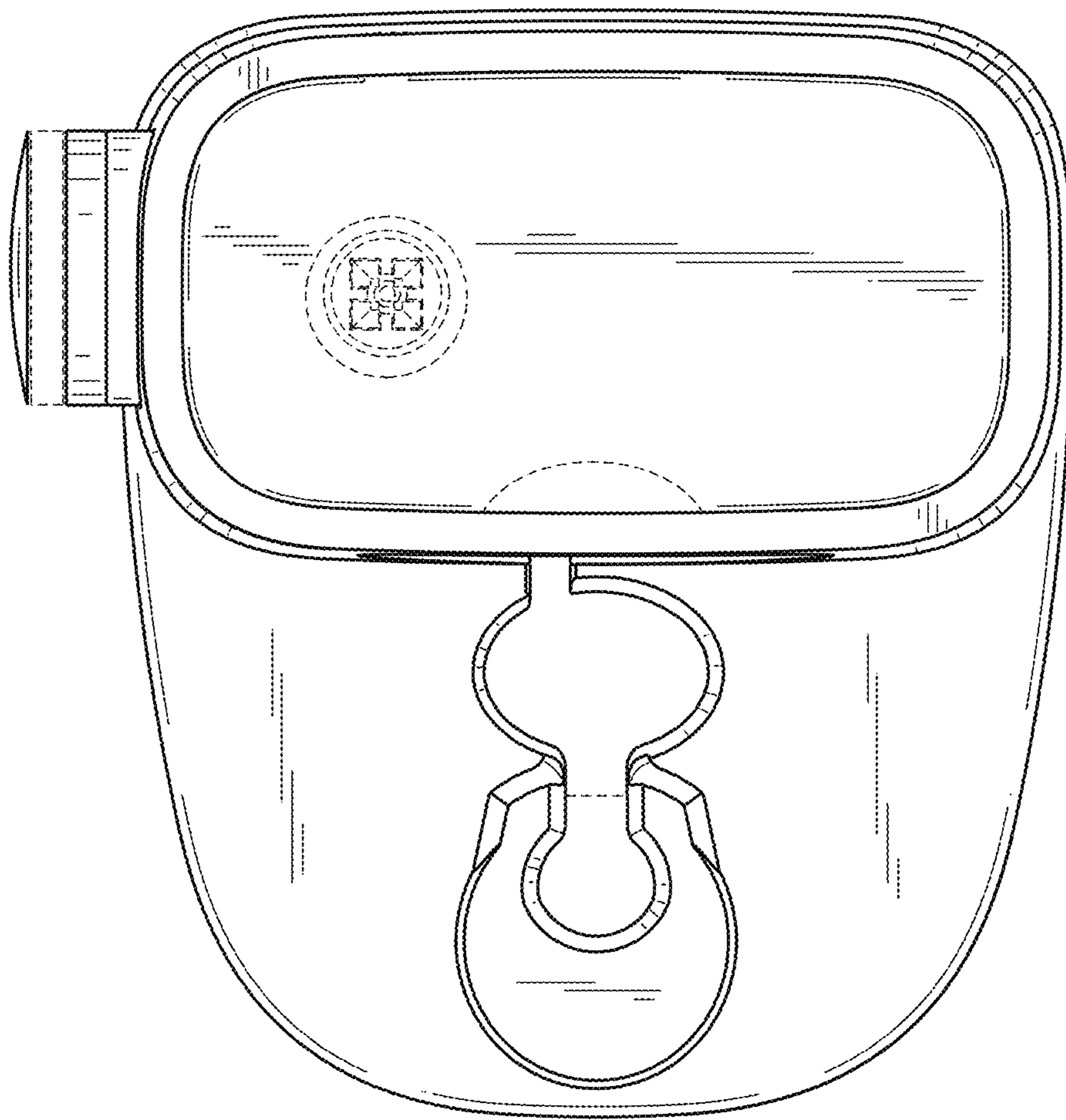

FIG. 7

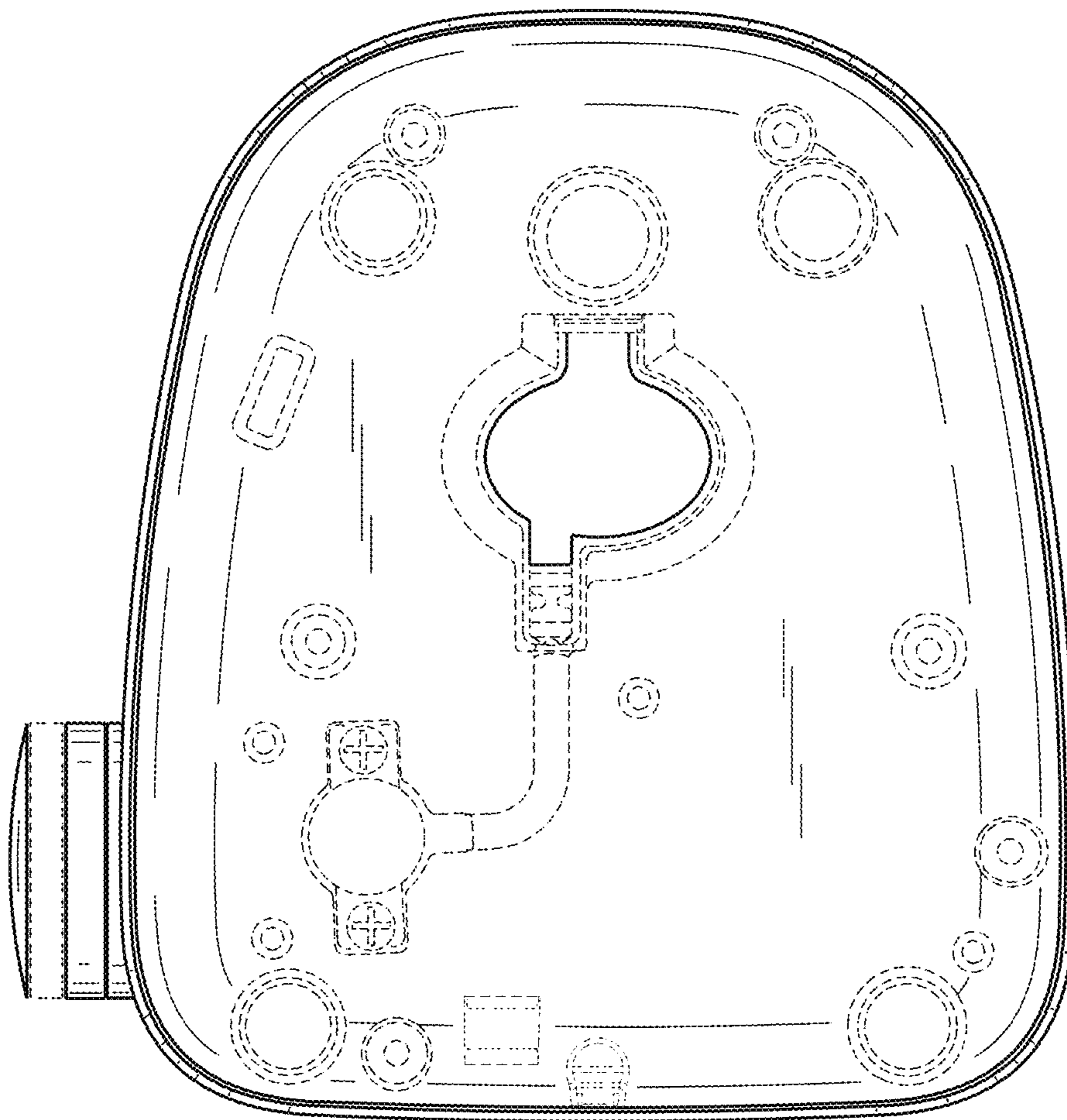

FIG. 8

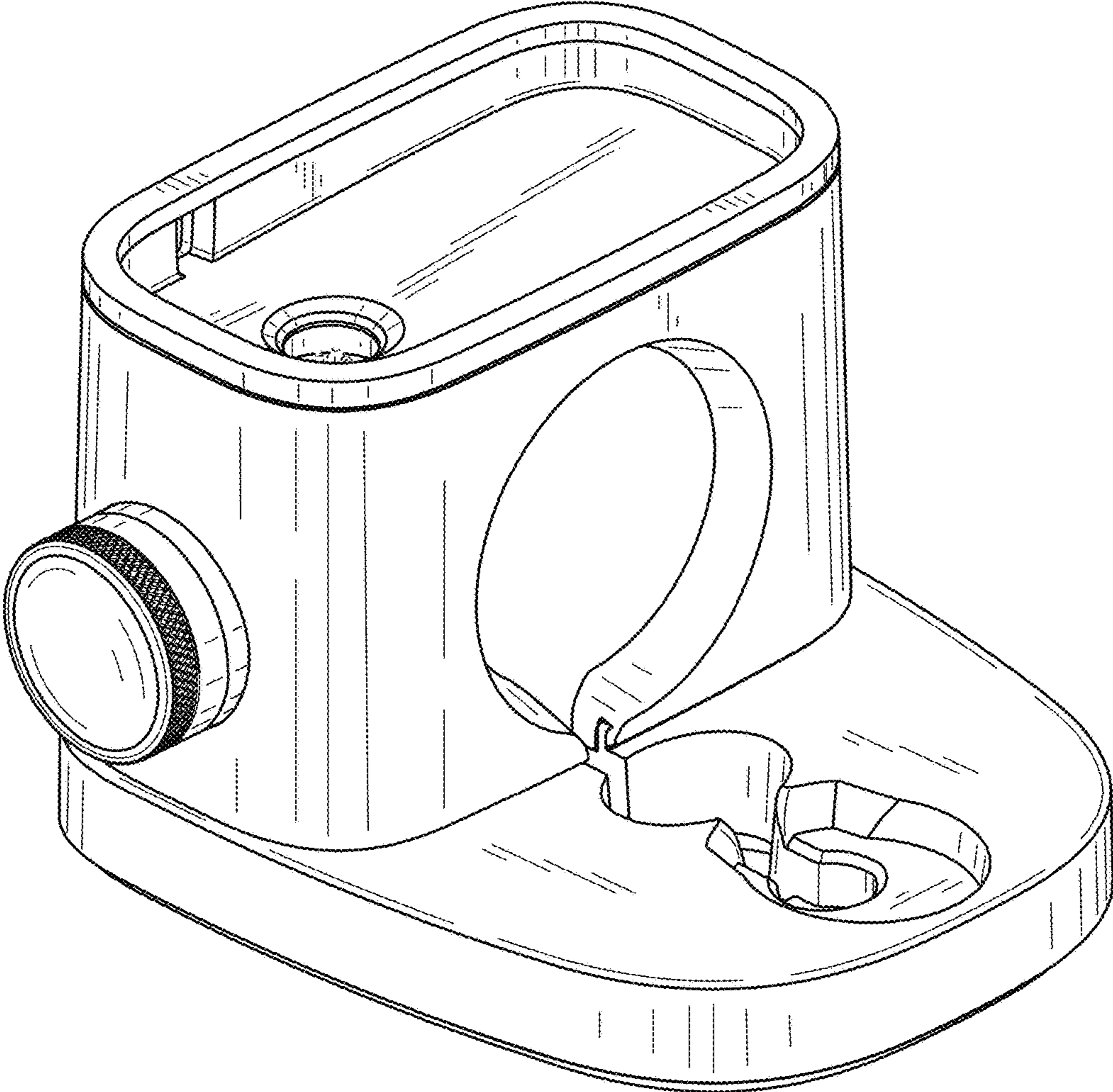

FIG. 9

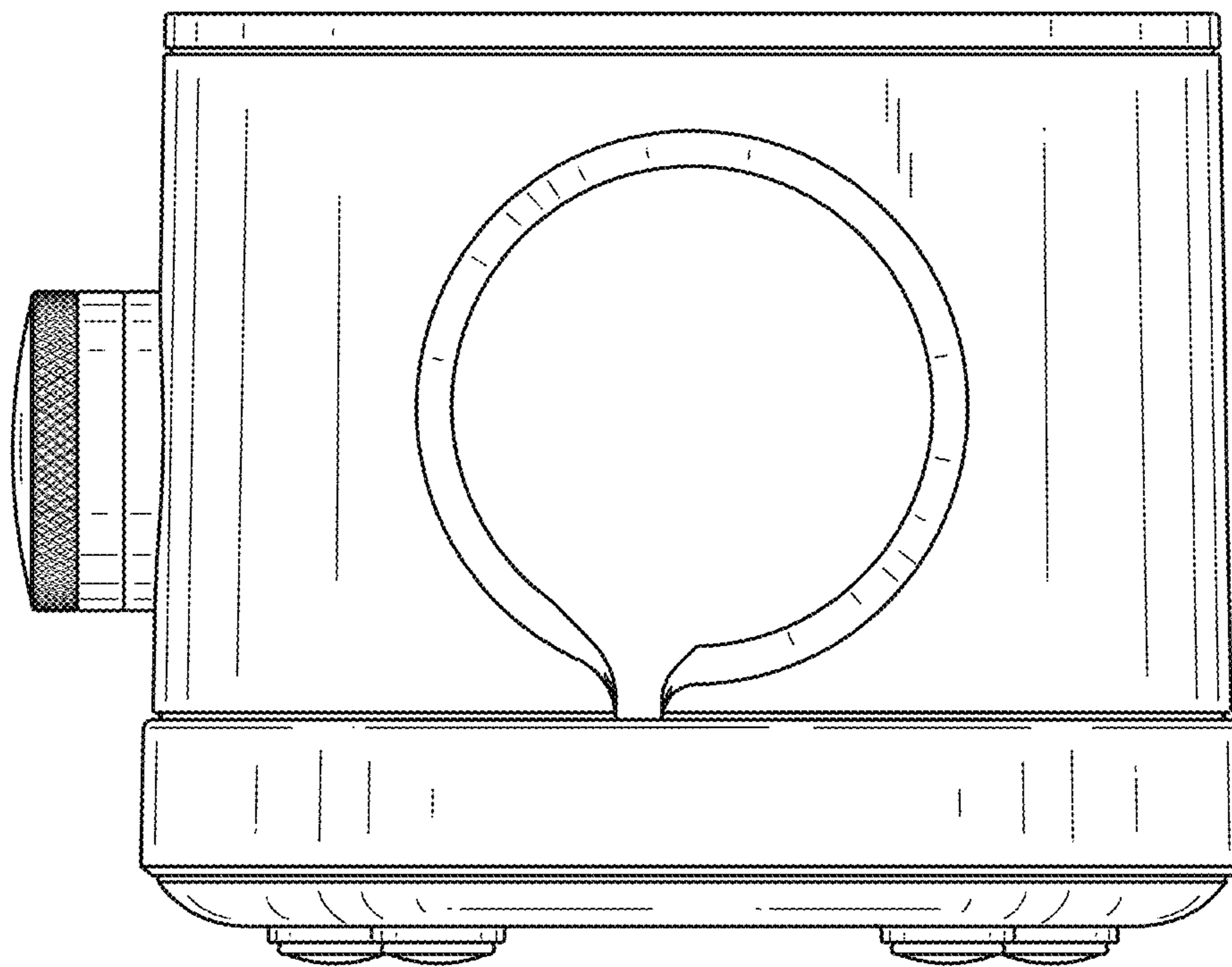

FIG. 10

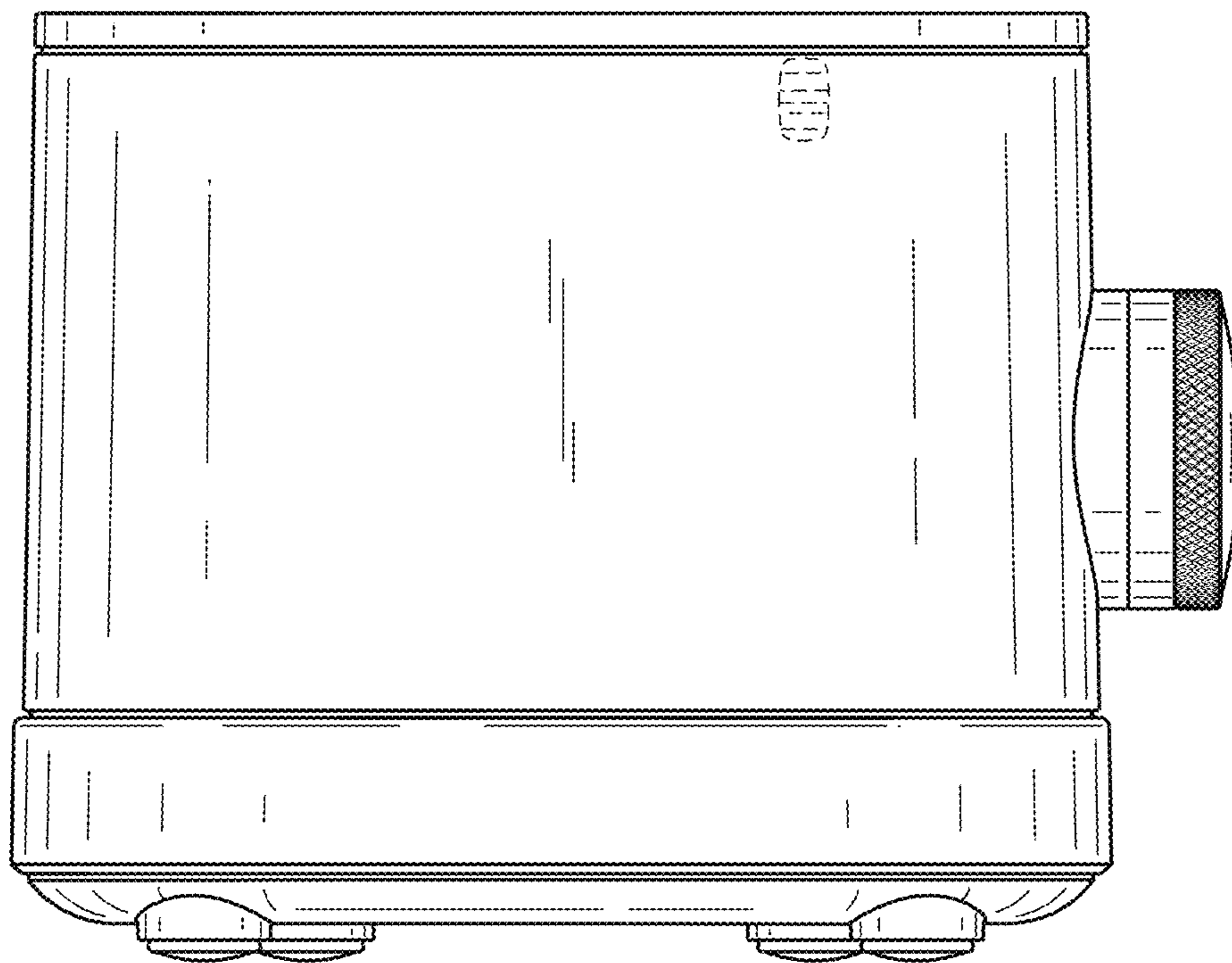

FIG. 11

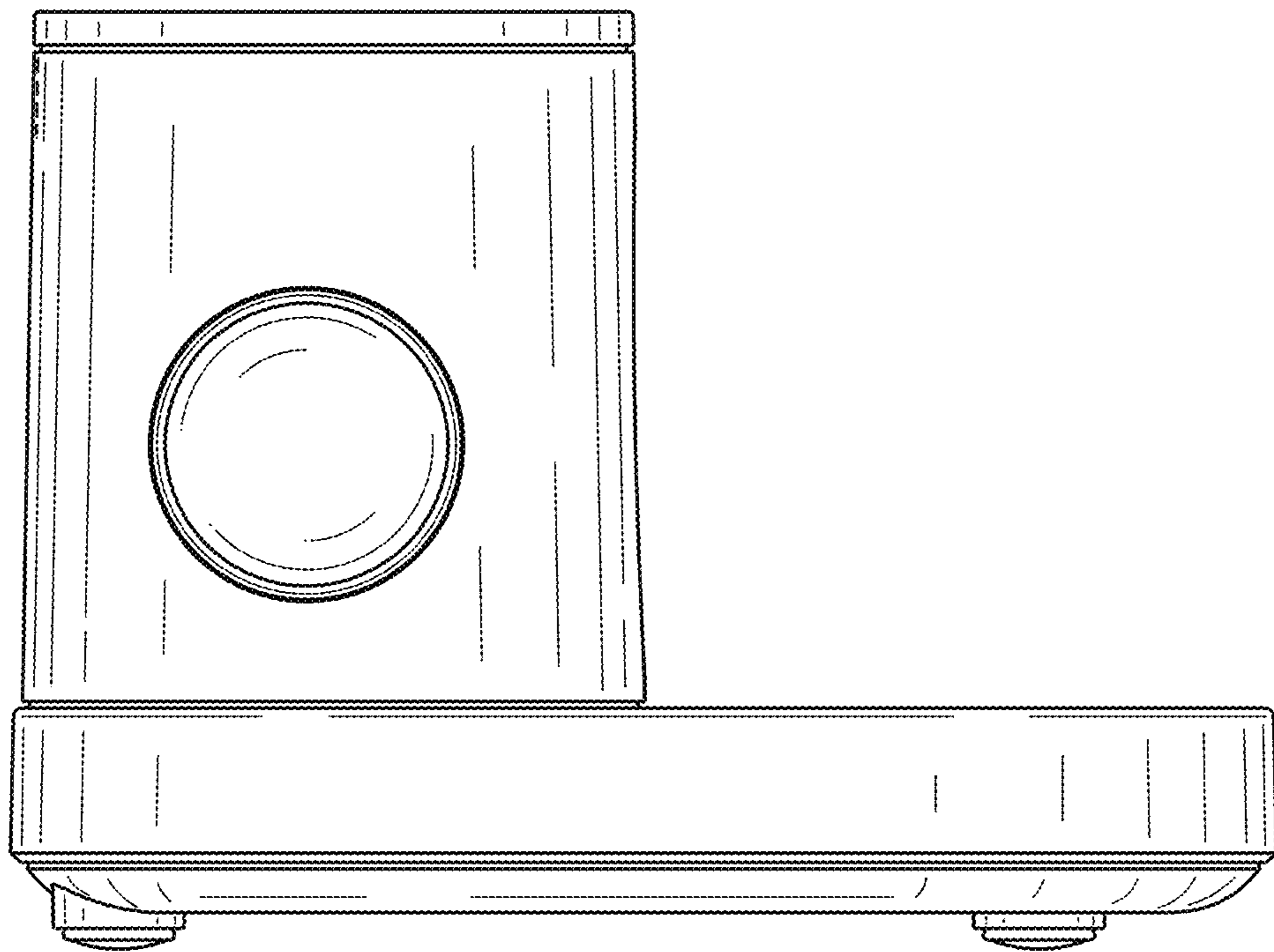

FIG. 12

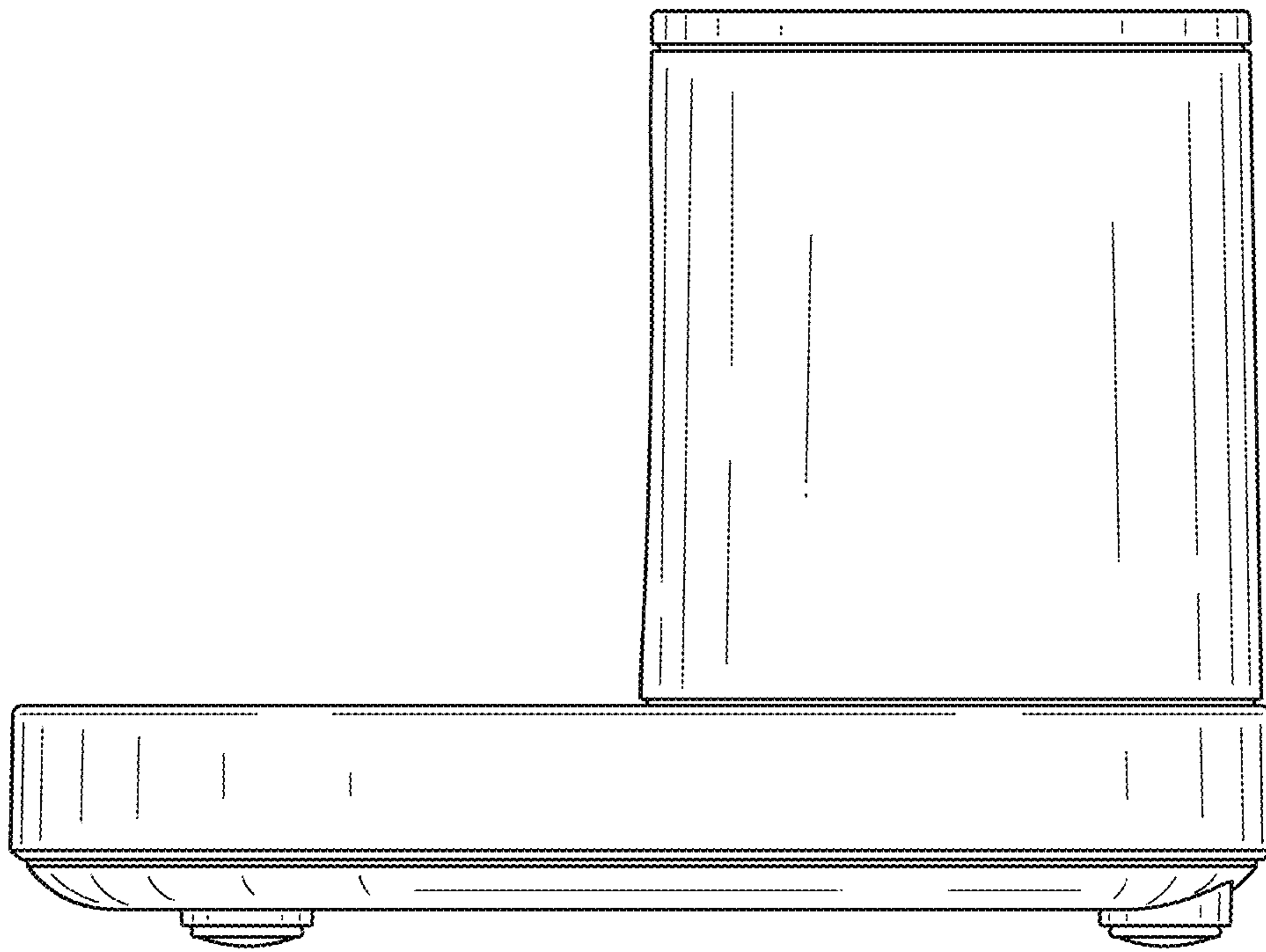

FIG. 13

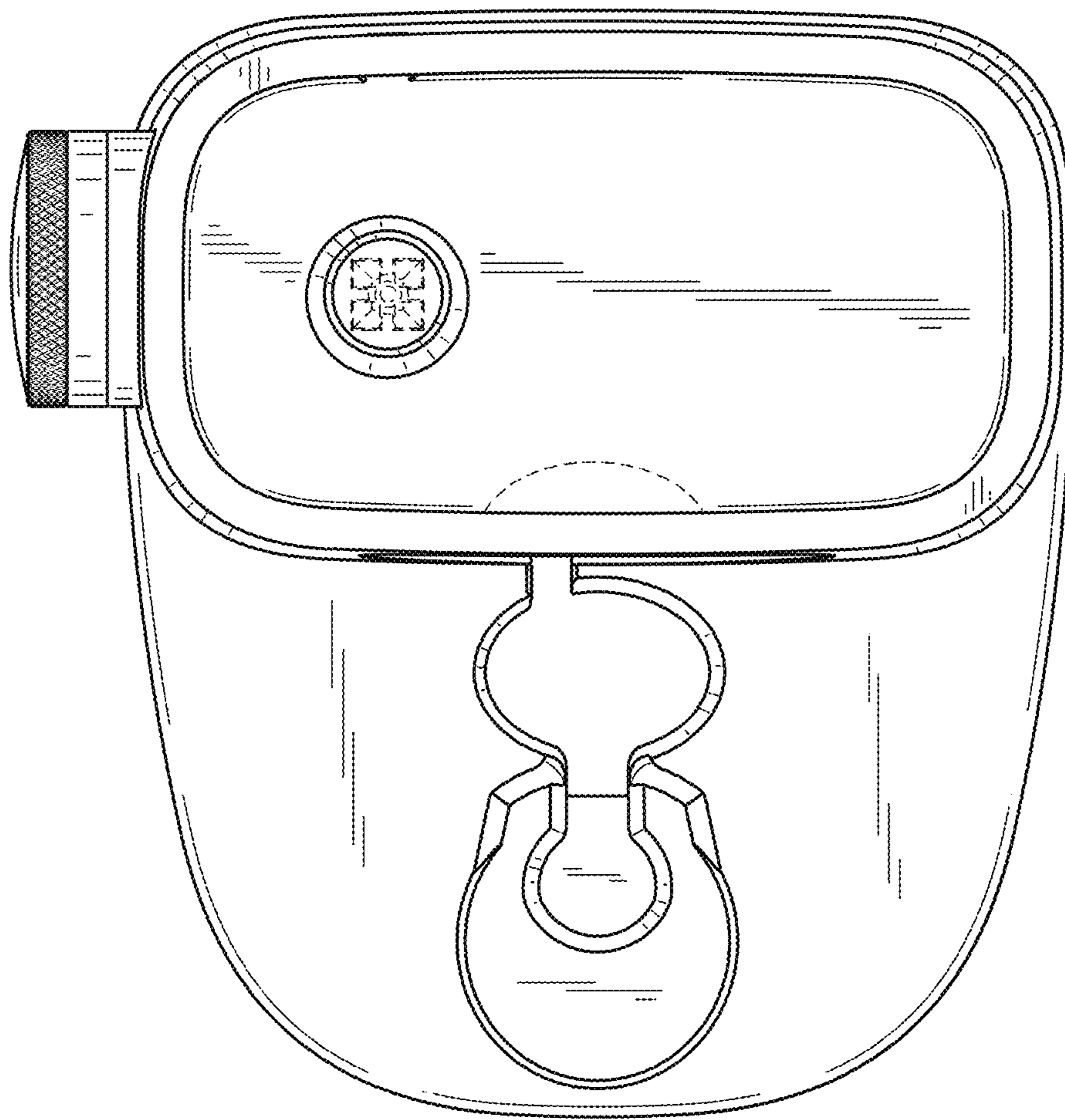

FIG. 14

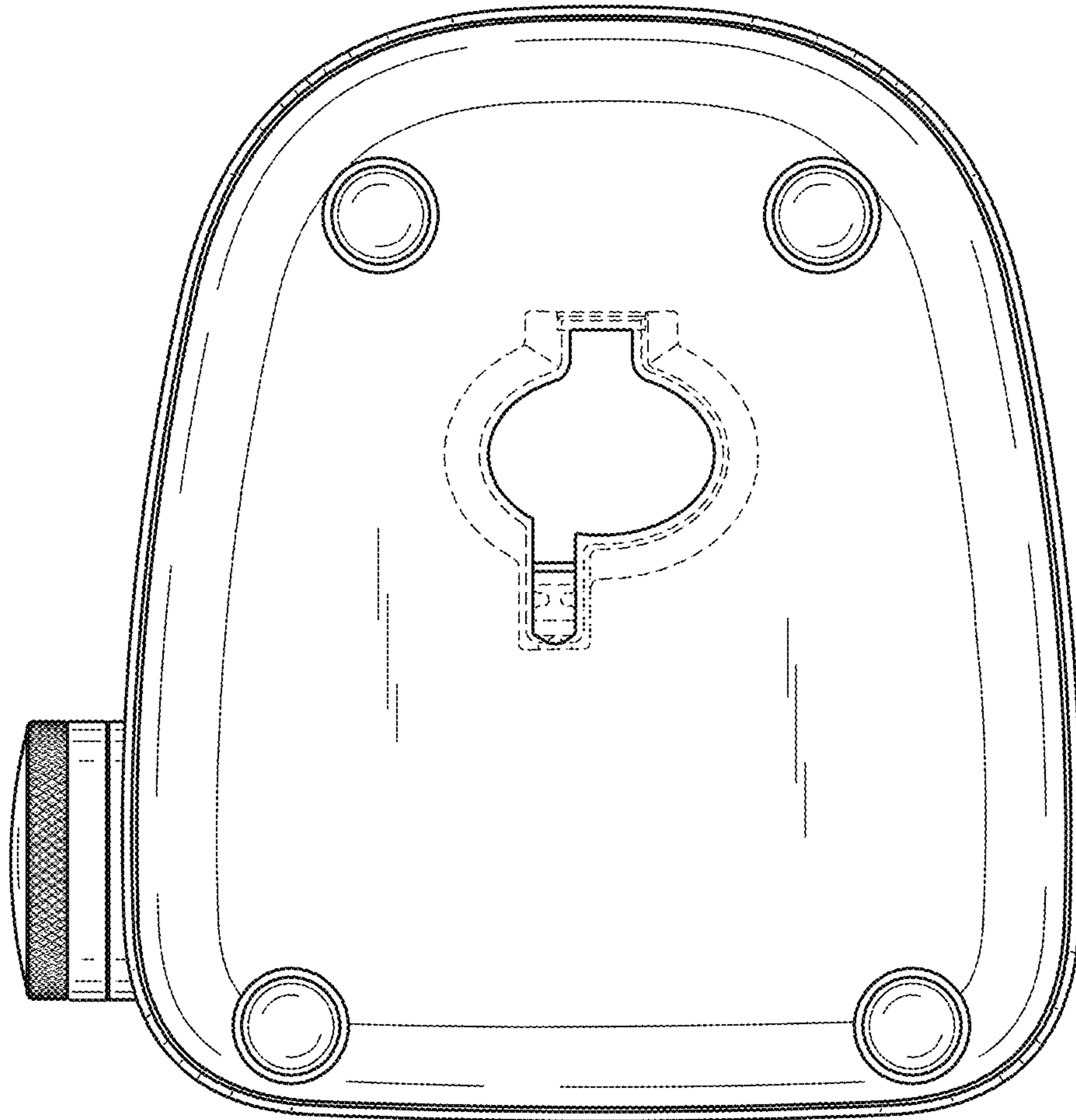

FIG. 15