



US00D832413S

(12) **United States Design Patent**  
**Chiang et al.**

(10) **Patent No.:** **US D832,413 S**  
(45) **Date of Patent:** **\*\* Oct. 30, 2018**

(54) **AIR-DUCT TYPE HEATING MODULE**

(71) Applicant: **Kogaku Technology Inc.**, Miaoli County (TW)

(72) Inventors: **Yueh-Lin Chiang**, Miaoli County (TW); **Hsin-Jan Pai**, Miaoli County (TW); **Ying-Feng Lee**, Miaoli County (TW); **Ling-Chiao Huang**, Miaoli County (TW)

(73) Assignee: **Kogaku Technology Inc.**, Miaoli County (TW)

(\*\*) Term: **15 Years**

(21) Appl. No.: **29/609,571**

(22) Filed: **Jun. 30, 2017**

(30) **Foreign Application Priority Data**

Jun. 9, 2017 (TW) ..... 106303138

(51) **LOC (11) Cl.** ..... **23-03**

(52) **U.S. Cl.**  
USPC ..... **D23/329**

(58) **Field of Classification Search**  
USPC ..... D23/314, 325, 329, 333, 334, 335, 342, D23/355, 356, 358, 359, 364, 386, 387, D23/388, 389, 390, 391, 317, 318, 323, D23/393, 392, 397, 499  
CPC ..... F28F 2215/00; H01L 21/67178; H01L 21/67173; H01L 21/67167; H01L 21/67098; F24F 2007/005; F24F 7/04; F24F 2012/008; F24F 12/001; F24F 12/003; F24F 13/04

See application file for complete search history.

(56) **References Cited**

**U.S. PATENT DOCUMENTS**

3,907,050 A \* 9/1975 Mullings ..... F24F 13/20 138/157  
D348,727 S \* 7/1994 Sawyer ..... D23/354

D378,402 S \* 3/1997 Ahmady ..... D23/330  
D560,276 S \* 1/2008 Whittenberger ..... D23/386  
D566,256 S \* 4/2008 Abate ..... D23/364  
D579,101 S \* 10/2008 Whittenberger ..... D23/386  
7,952,869 B2 \* 5/2011 Lewis, II ..... H05K 7/20736 165/104.33  
8,040,673 B2 \* 10/2011 Krietzman ..... H05K 7/20736 165/104.19  
8,107,238 B2 \* 1/2012 Krietzman ..... H05K 7/20745 165/104.19  
8,973,951 B2 \* 3/2015 Nicewicz ..... H05K 7/20745 285/145.1

(Continued)

*Primary Examiner* — T Chase Nelson

*Assistant Examiner* — Ania Aman

(74) *Attorney, Agent, or Firm* — Martine Penilla Group, LLP

(57) **CLAIM**

The ornamental design for an air-duct type heating module, as shown and described.

**DESCRIPTION**

FIG. 1 is a perspective view from the top of an air-duct type heating module.  
FIG. 2 is a front view of the air-duct type heating module.  
FIG. 3 is a rear view of the air-duct type heating module.  
FIG. 4 is a left side view of the air-duct type heating module.  
FIG. 5 is a right side view of the air-duct type heating module.  
FIG. 6 is a top view of the air-duct type heating module.  
FIG. 7 is a bottom view of the air-duct type heating module; and,  
FIG. 8 is a perspective view from the bottom of the air-duct type heating module.

**1 Claim, 8 Drawing Sheets**

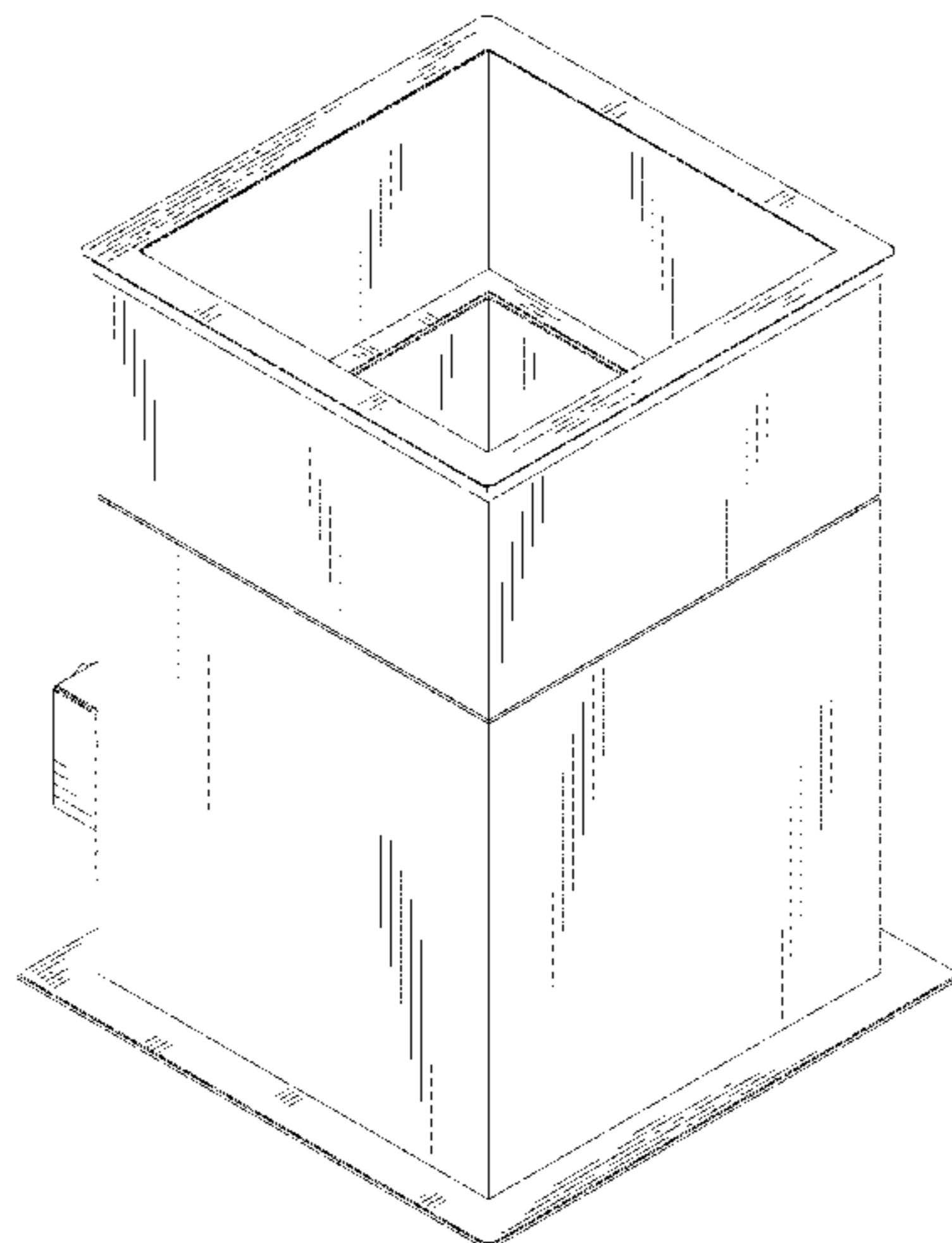

(56)

**References Cited**

U.S. PATENT DOCUMENTS

2003/0213853 A1\* 11/2003 Demster ..... E04B 9/02  
236/49.3  
2004/0144316 A1\* 7/2004 Lee ..... C23C 14/566  
118/719  
2007/0218706 A1\* 9/2007 Matsuoka ..... F27B 5/04  
438/781  
2009/0190307 A1\* 7/2009 Krietzman ..... H05K 7/20736  
361/690  
2015/0079719 A1\* 3/2015 Can ..... H01L 31/18  
438/61  
2016/0013084 A1\* 1/2016 Kamata ..... H01L 21/67775  
34/476  
2018/0010720 A1\* 1/2018 Duggan ..... F16L 23/006

\* cited by examiner

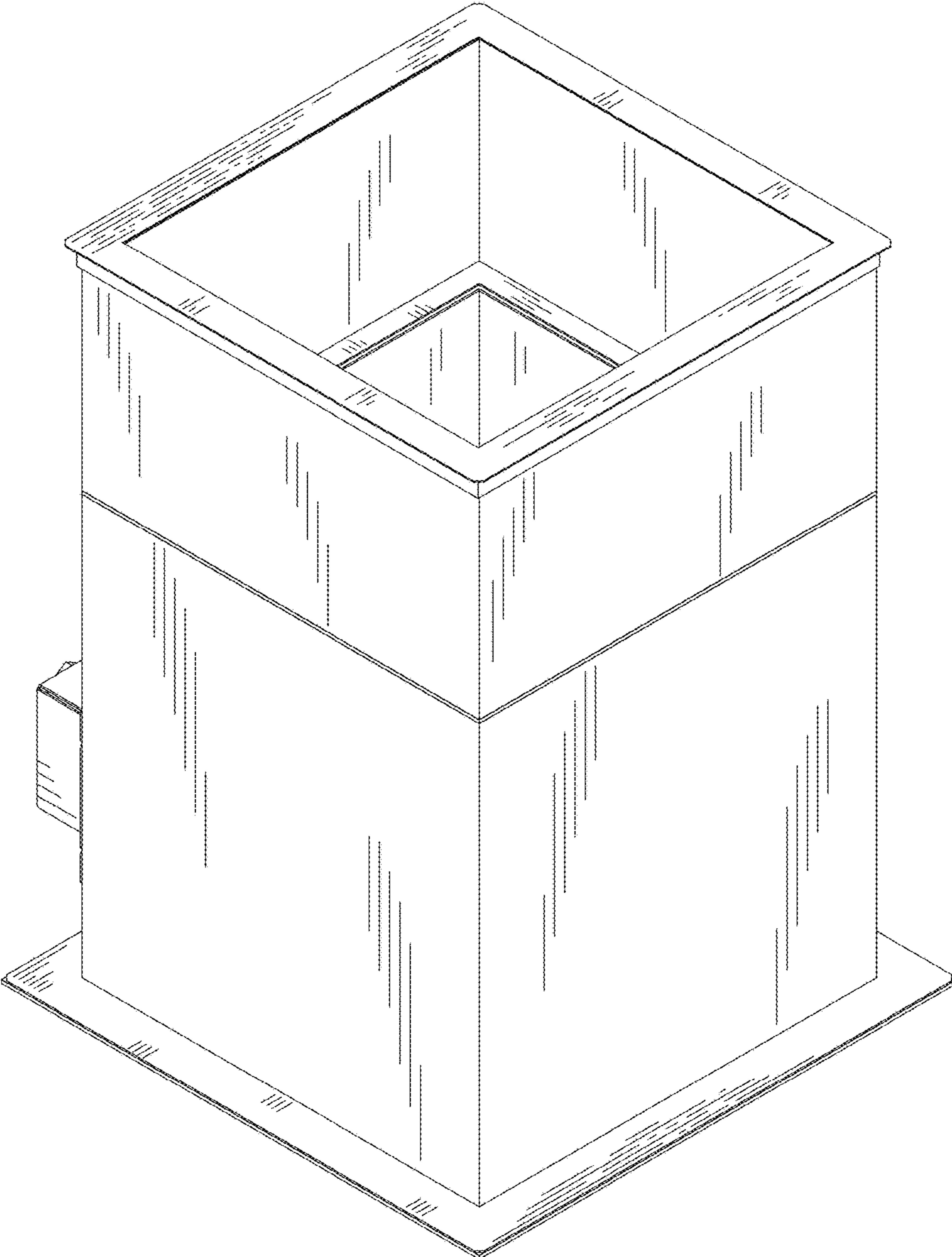

FIG. 1

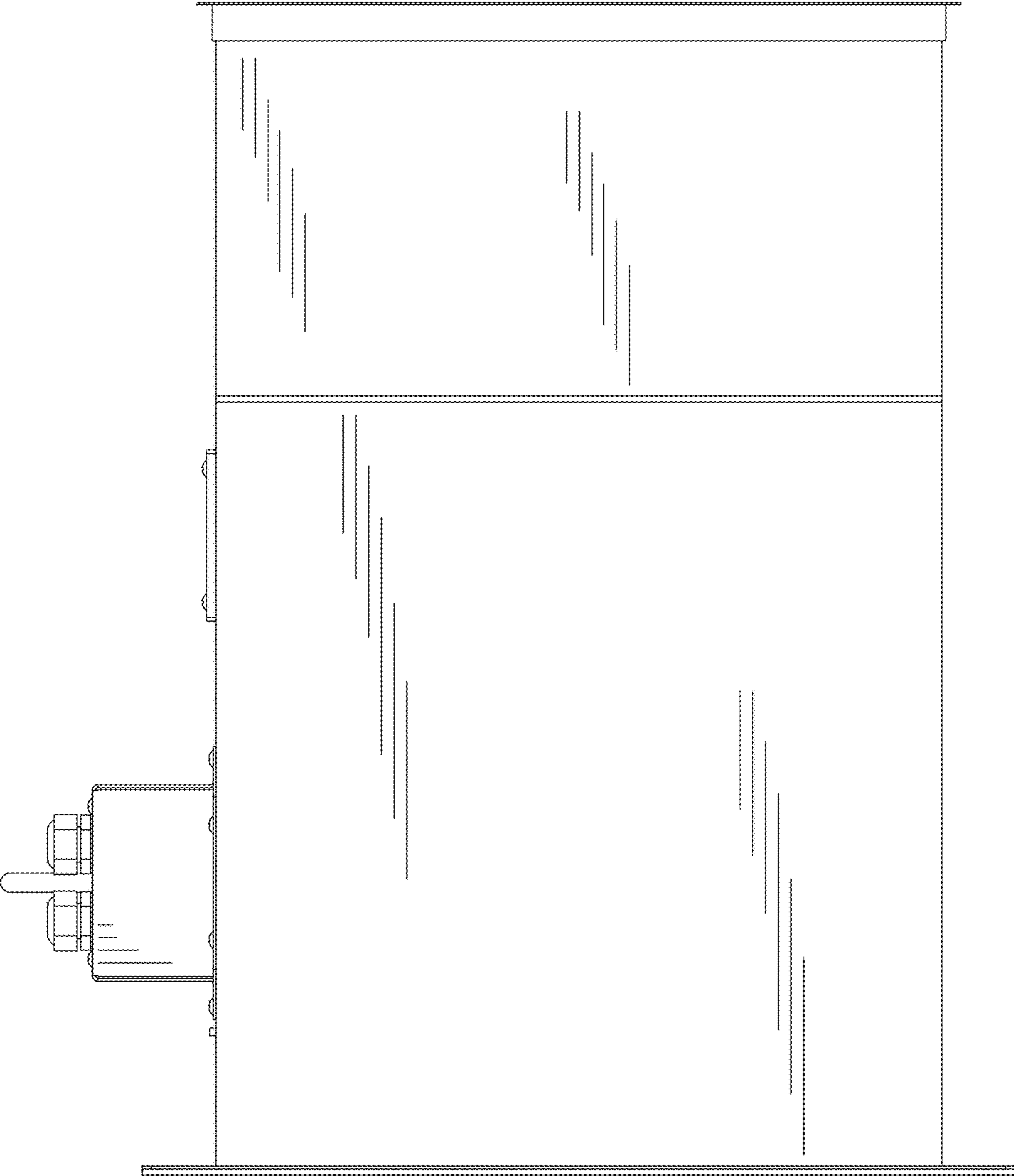

FIG. 2

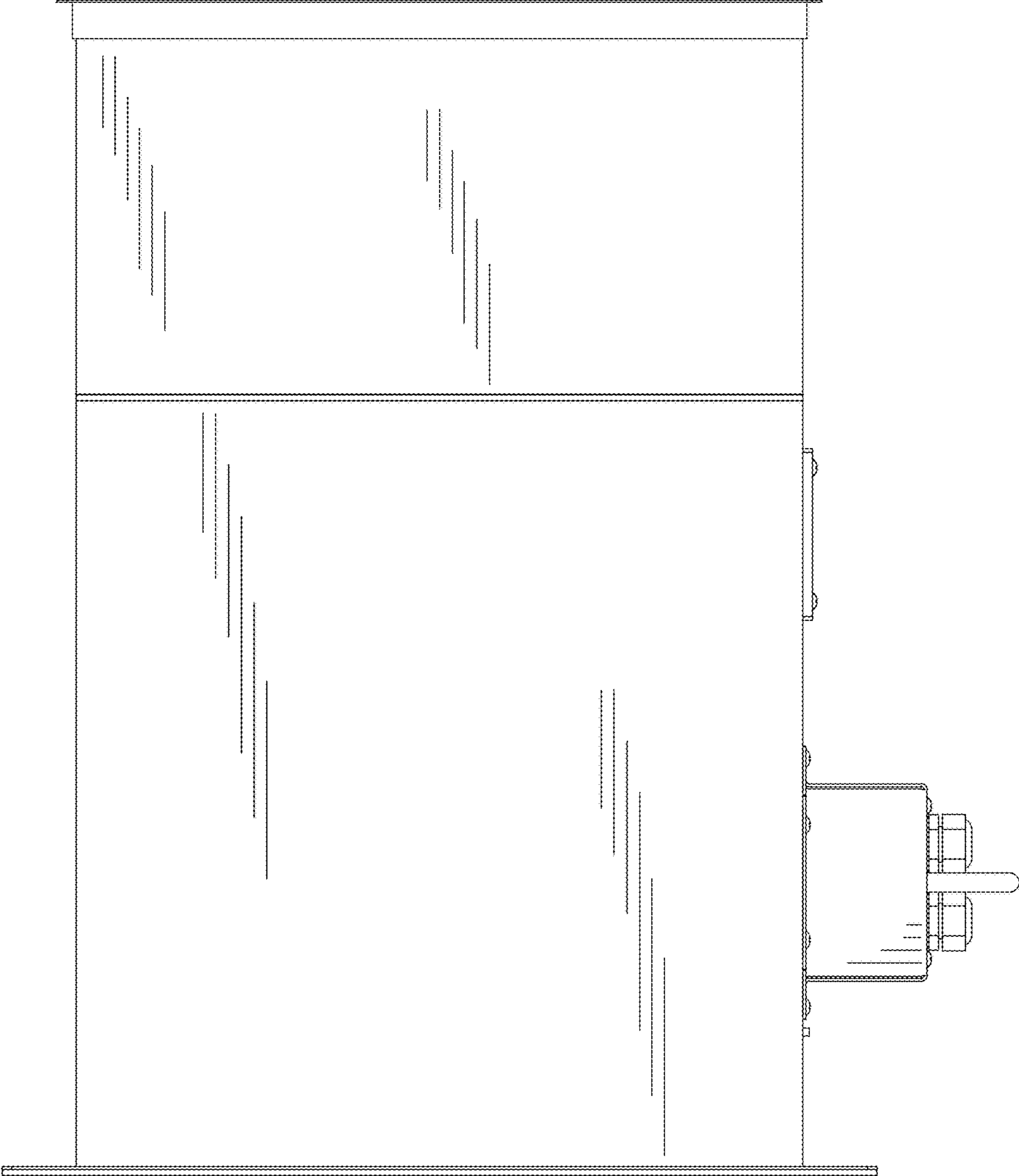

FIG. 3

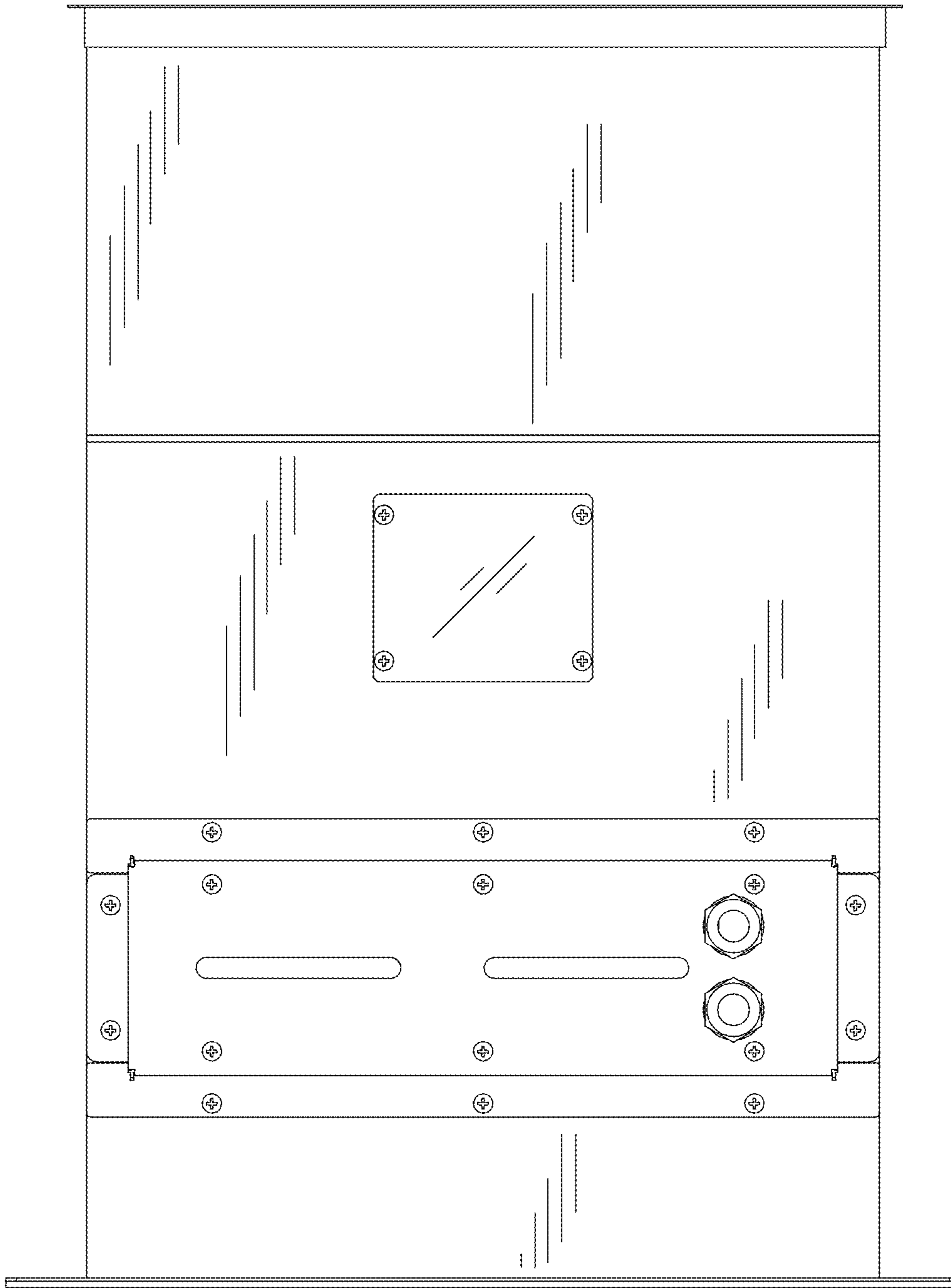

FIG. 4



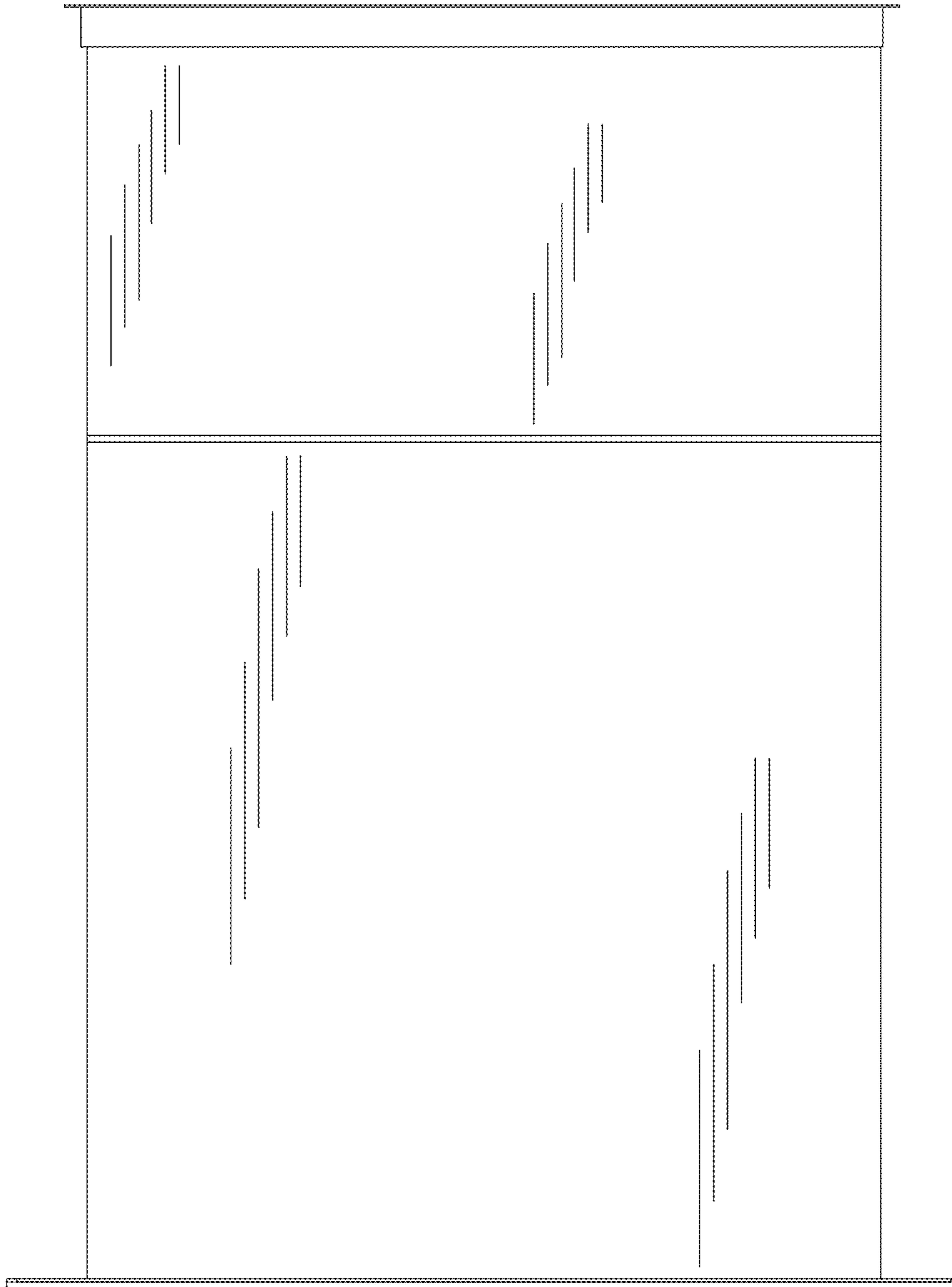

FIG. 5

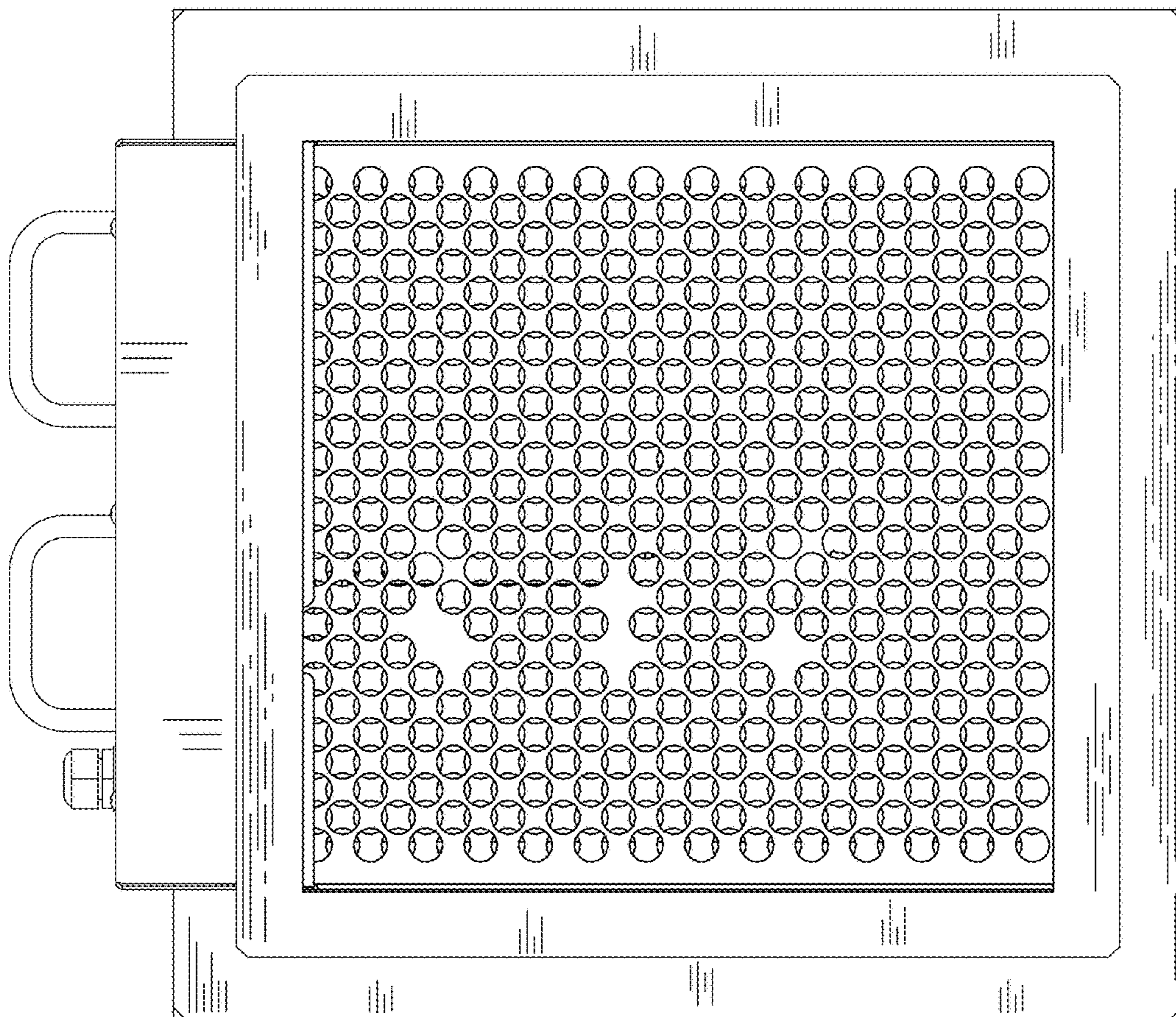

FIG. 6



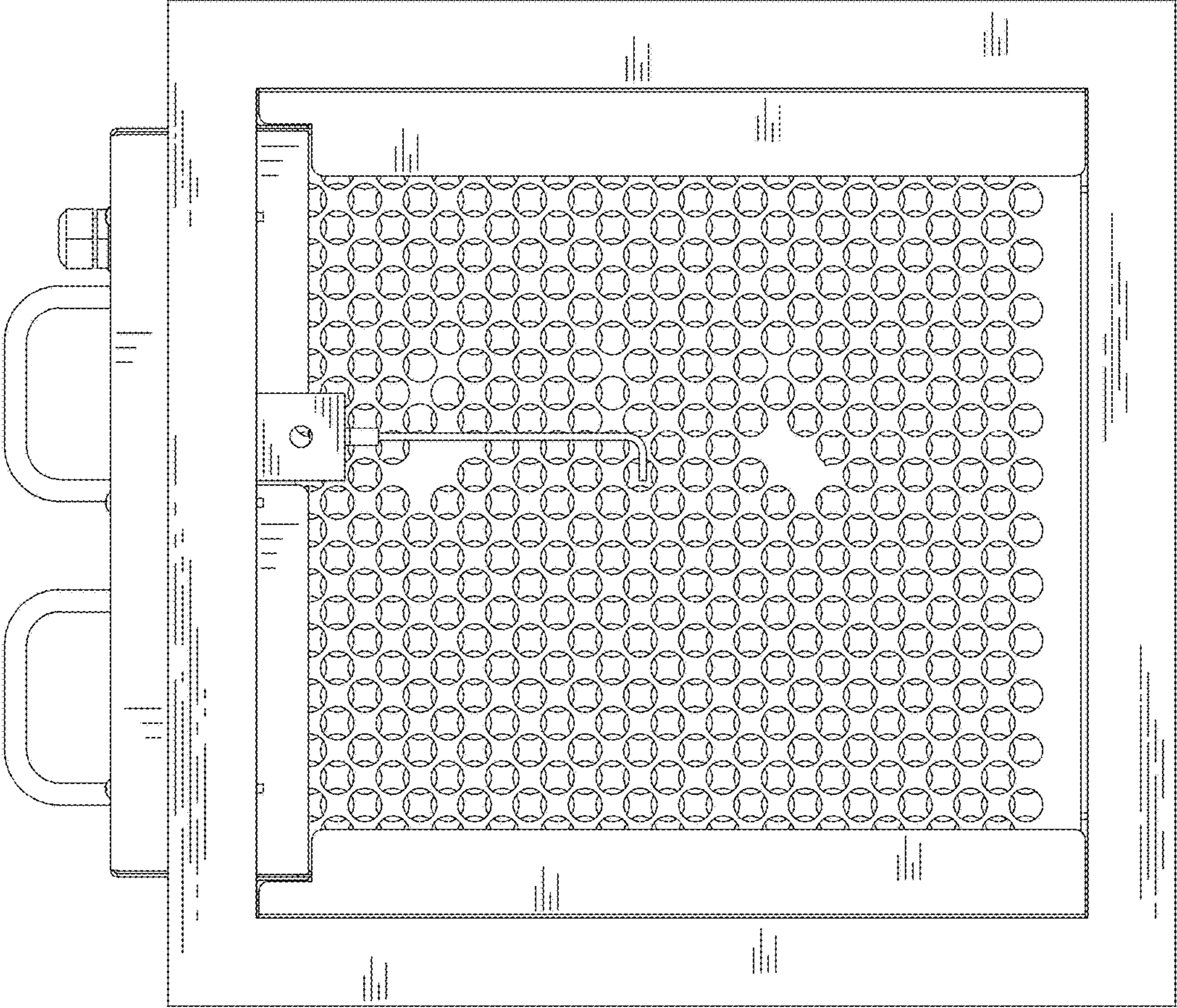

FIG. 7

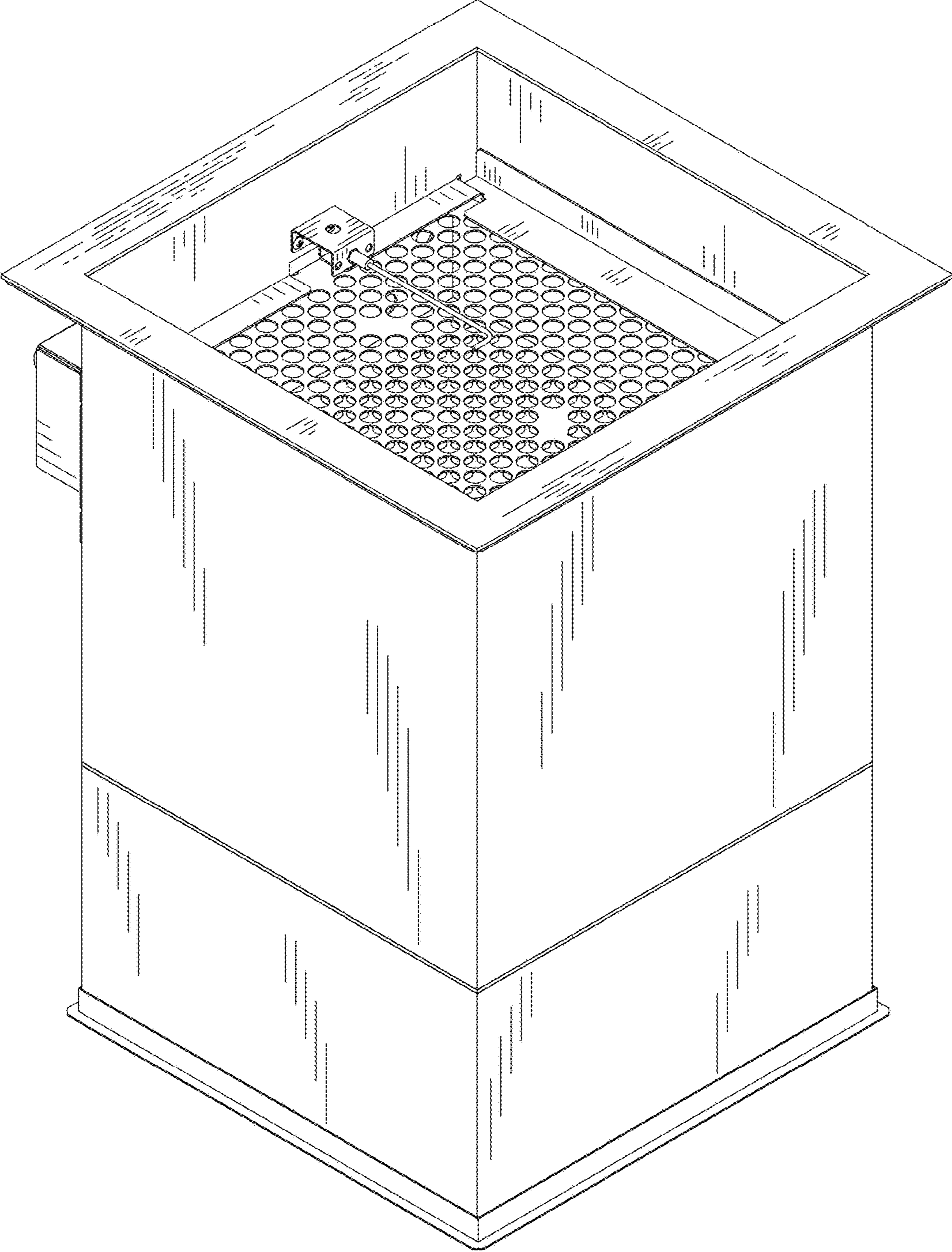

FIG. 8