



US00D832182S

(12) **United States Design Patent**
Peat

(10) **Patent No.:** **US D832,182 S**

(45) **Date of Patent:** **** Oct. 30, 2018**

(54) **WHEEL**

(71) Applicant: **Jaguar Land Rover Limited**, Whitley,
Coventry (GB)

(72) Inventor: **Anthony Peat**, Coventry (GB)

(73) Assignee: **Jaguar Land Rover Limited**, Whitley
Coventry (GB)

(**) Term: **15 Years**

(21) Appl. No.: **29/627,040**

(22) Filed: **Nov. 22, 2017**

Related U.S. Application Data

(62) Division of application No. 29/579,547, filed on Sep.
30, 2016, now Pat. No. Des. 806,632.

(30) **Foreign Application Priority Data**

Apr. 25, 2016 (EM) 003085992-0001

(51) **LOC (11) Cl.** **12-16**

(52) **U.S. Cl.**
USPC **D12/211**

(58) **Field of Classification Search**

USPC D12/204–213
CPC B60B 7/00; B60B 7/02; B60B 7/04; B60B
7/01; B60B 7/06; B60B 3/02; B60B 3/04;
B60B 3/06; B60B 3/10; B60B 1/00;
B60B 1/08; B60B 1/10; B60B 1/12

See application file for complete search history.

(56) **References Cited**

U.S. PATENT DOCUMENTS

D617,719 S * 6/2010 Zhao D12/211
D618,156 S * 6/2010 Zhao D12/211
D619,952 S * 7/2010 Juergens D12/211
D667,769 S * 9/2012 Pollmann D12/209

D671,480 S * 11/2012 Cepkova D12/209
D688,185 S * 8/2013 Baum D12/209
D712,331 S * 9/2014 Breyton D12/209
D723,996 S * 3/2015 Zhao D12/211
D751,488 S * 3/2016 Zhao D12/211
D768,048 S * 10/2016 Johnson D12/211

(Continued)

Primary Examiner — Stacia A Cadmus

(74) *Attorney, Agent, or Firm* — Wood Herron & Evans
LLP

(57) **CLAIM**

The ornamental design for a wheel, as shown and described.

DESCRIPTION

FIG. 1 is a left front perspective view of a wheel according
to the present invention.

FIG. 2 is a right front perspective view of the wheel shown
in FIG. 1.

FIG. 3 is a front view thereof.

FIG. 4 is a left side view thereof, the right side view being
a mirror image thereof.

FIG. 5 is a rear view thereof.

FIG. 6 is a left rear perspective view thereof.

FIG. 7 is a left front perspective view of a wheel according
to a second embodiment of the present invention.

FIG. 8 is a right front perspective view of the wheel shown
in FIG. 7.

FIG. 9 is a front view thereof.

FIG. 10 is a left side view thereof, the right side view being
a mirror image thereof.

FIG. 11 is a rear view thereof; and,

FIG. 12 is a left rear perspective view thereof.

The broken lines comprise claim boundaries and neither the
portions inside the broken lines nor the broken lines them-
selves form any part of the claimed invention. Also, the
broken lines shown adjacent to the shaded portions form an
unclaimed boundary of the design.

1 Claim, 8 Drawing Sheets

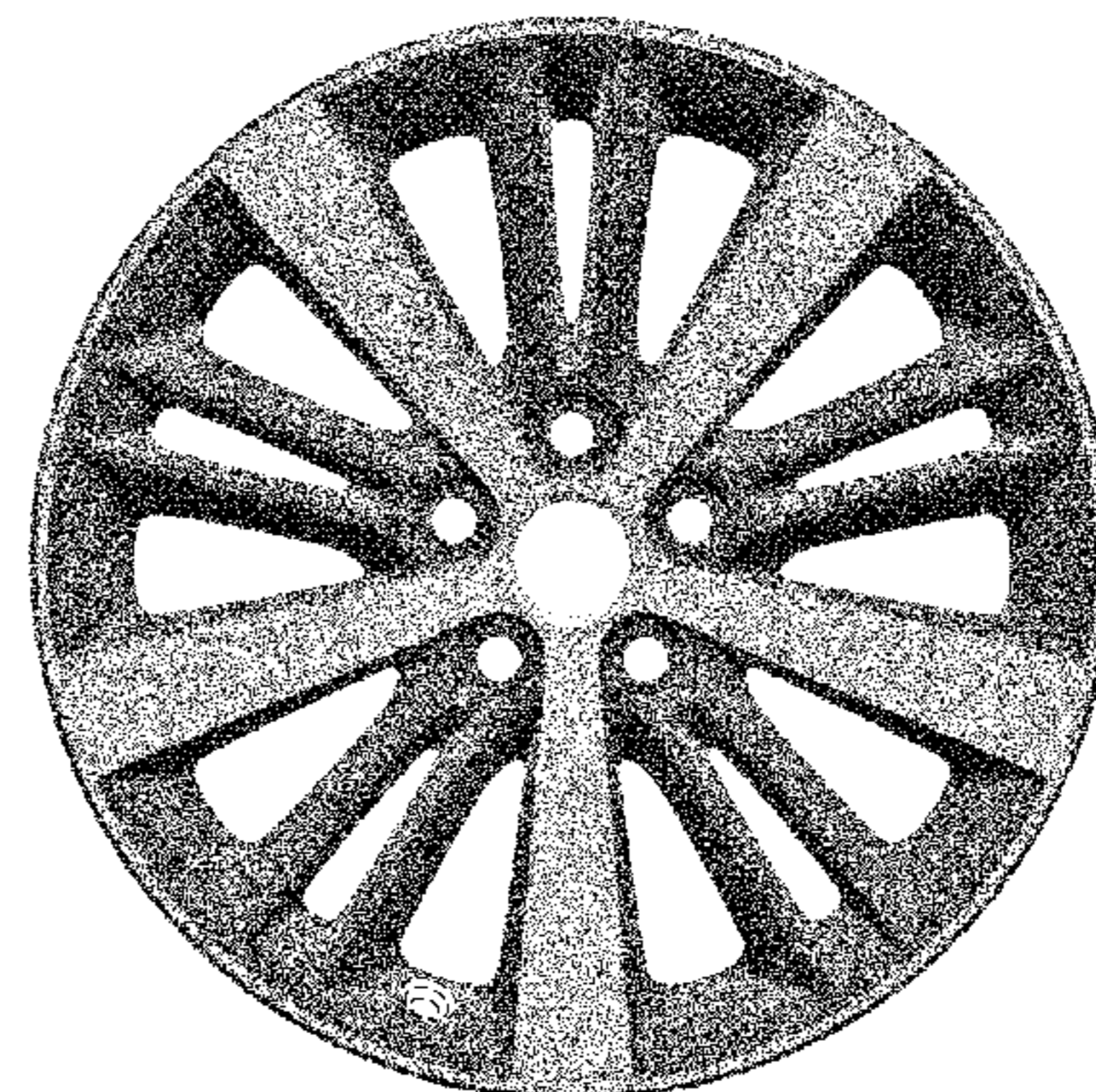
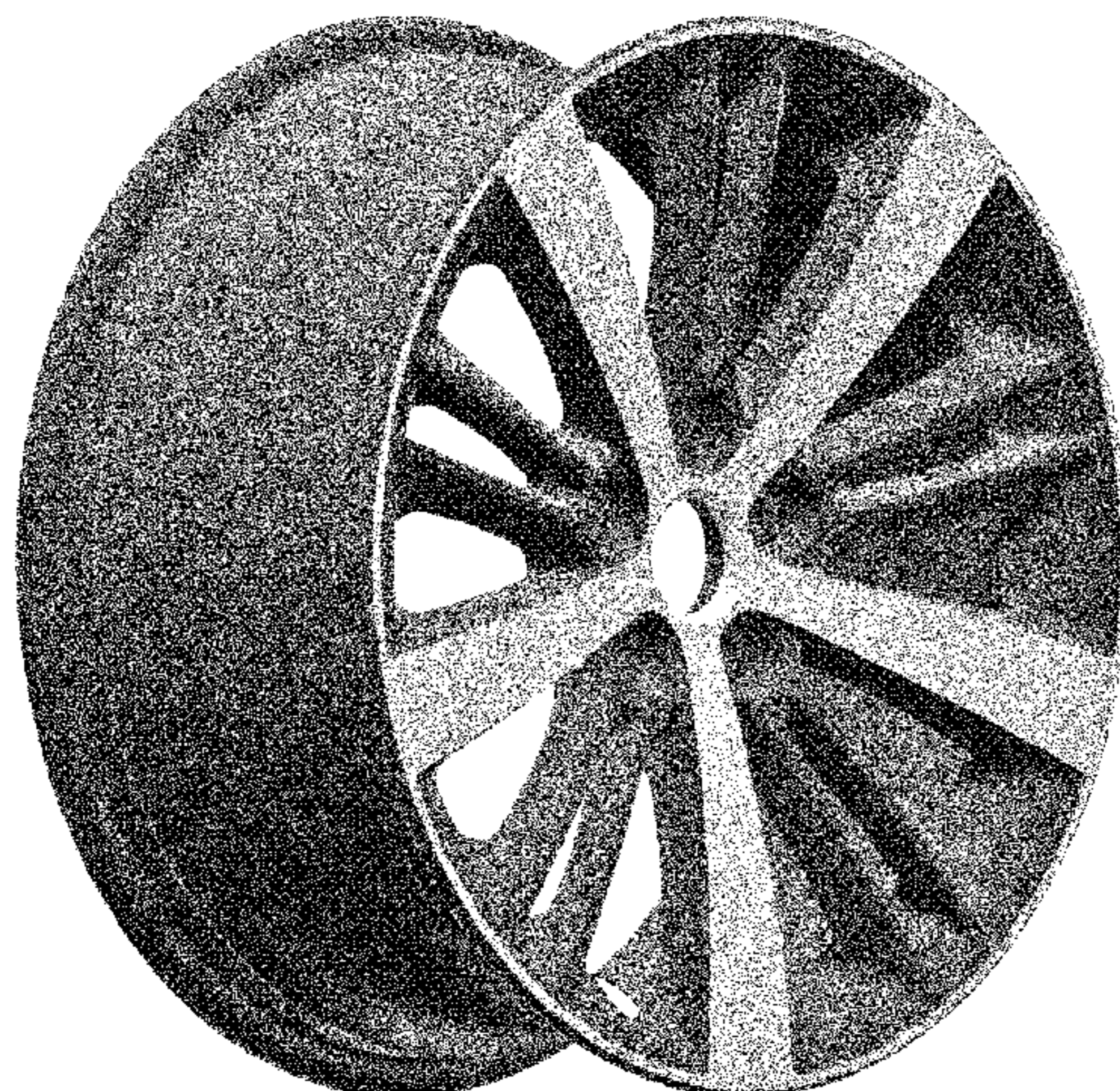

(56)

References Cited

U.S. PATENT DOCUMENTS

D777,640 S * 1/2017 Bazinski D12/211
D792,311 S * 7/2017 Gallert D12/211
D806,632 S * 1/2018 Peat D12/211

* cited by examiner



FIG. 1

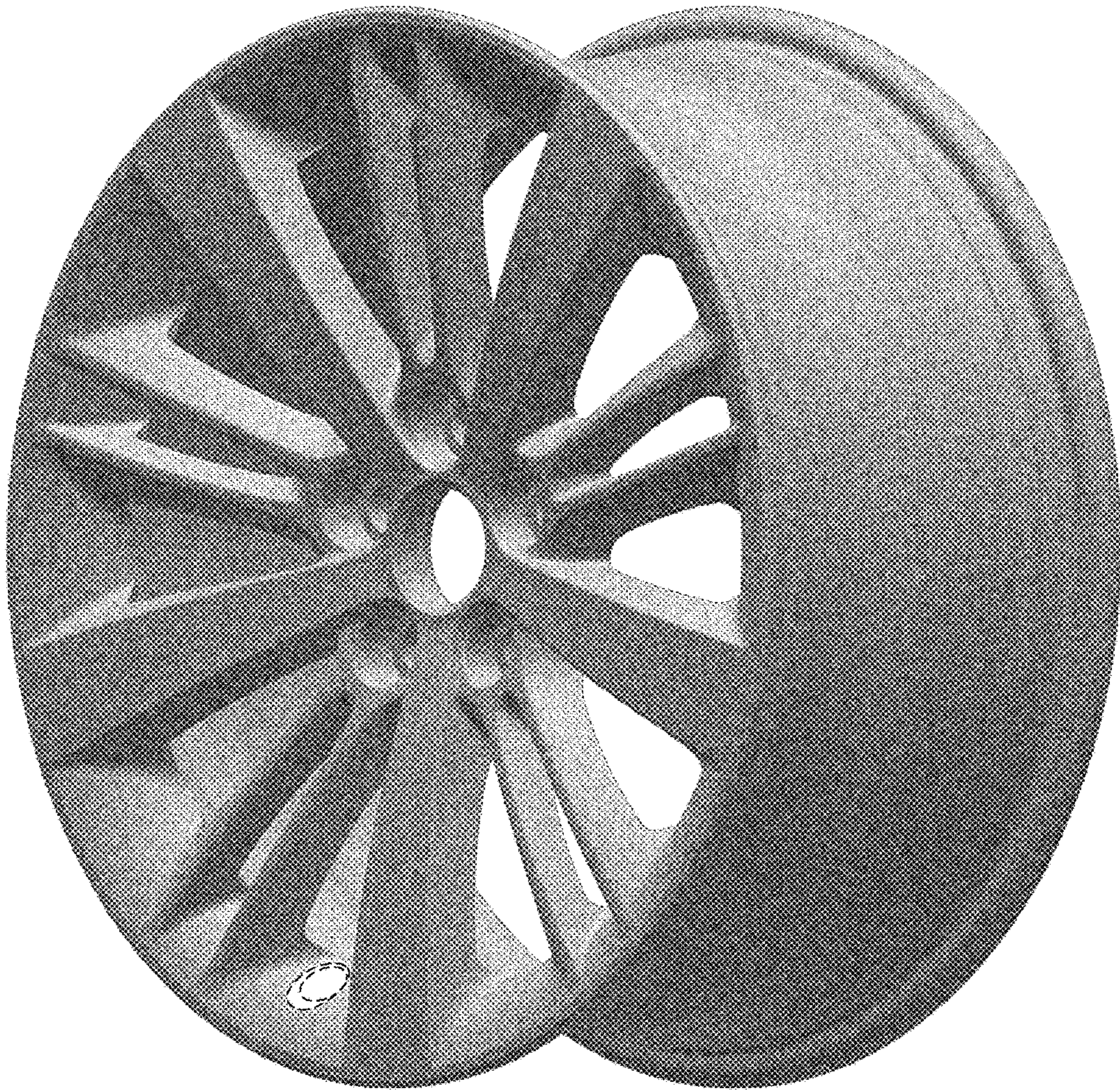

FIG. 2

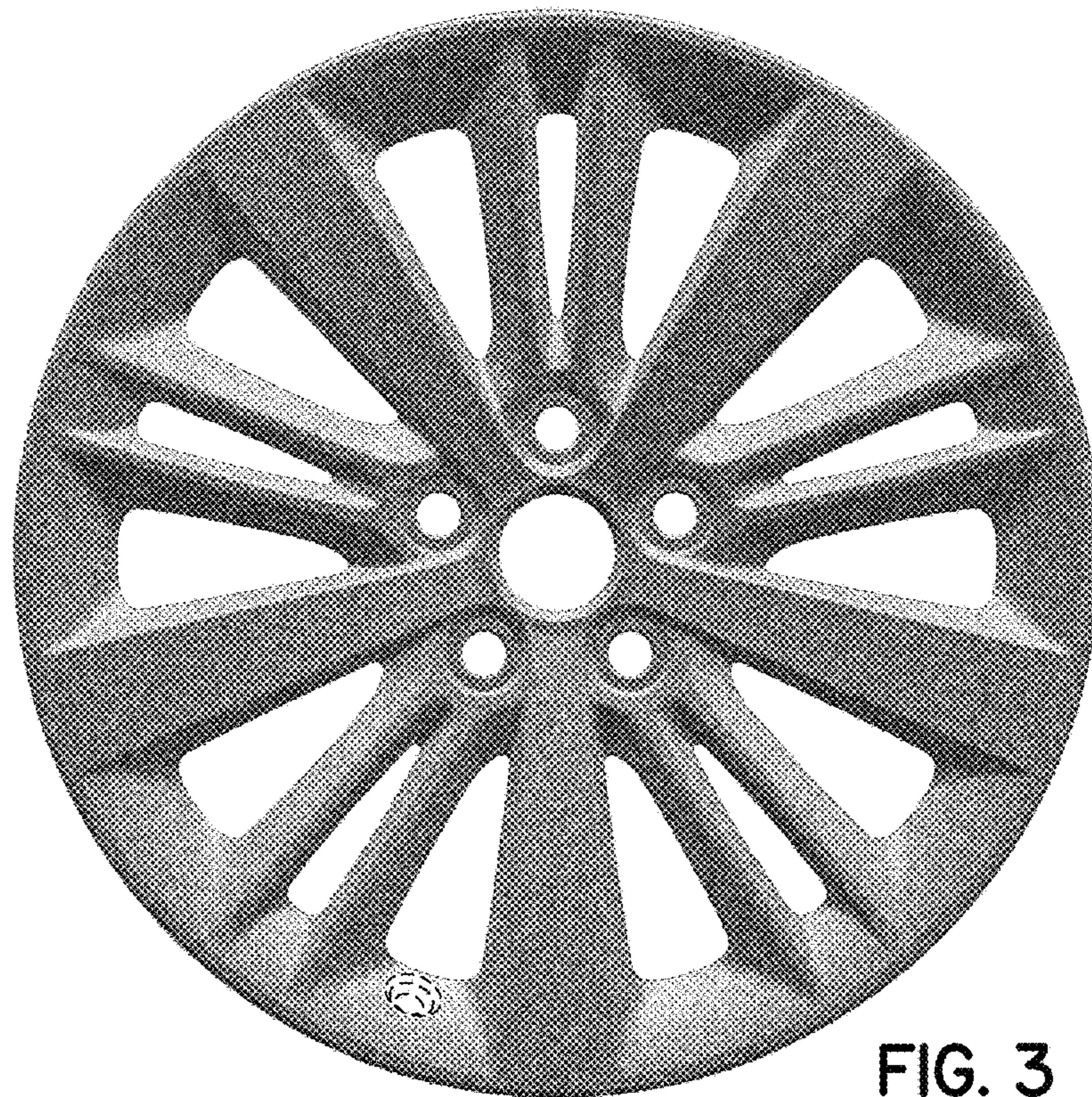

FIG. 3

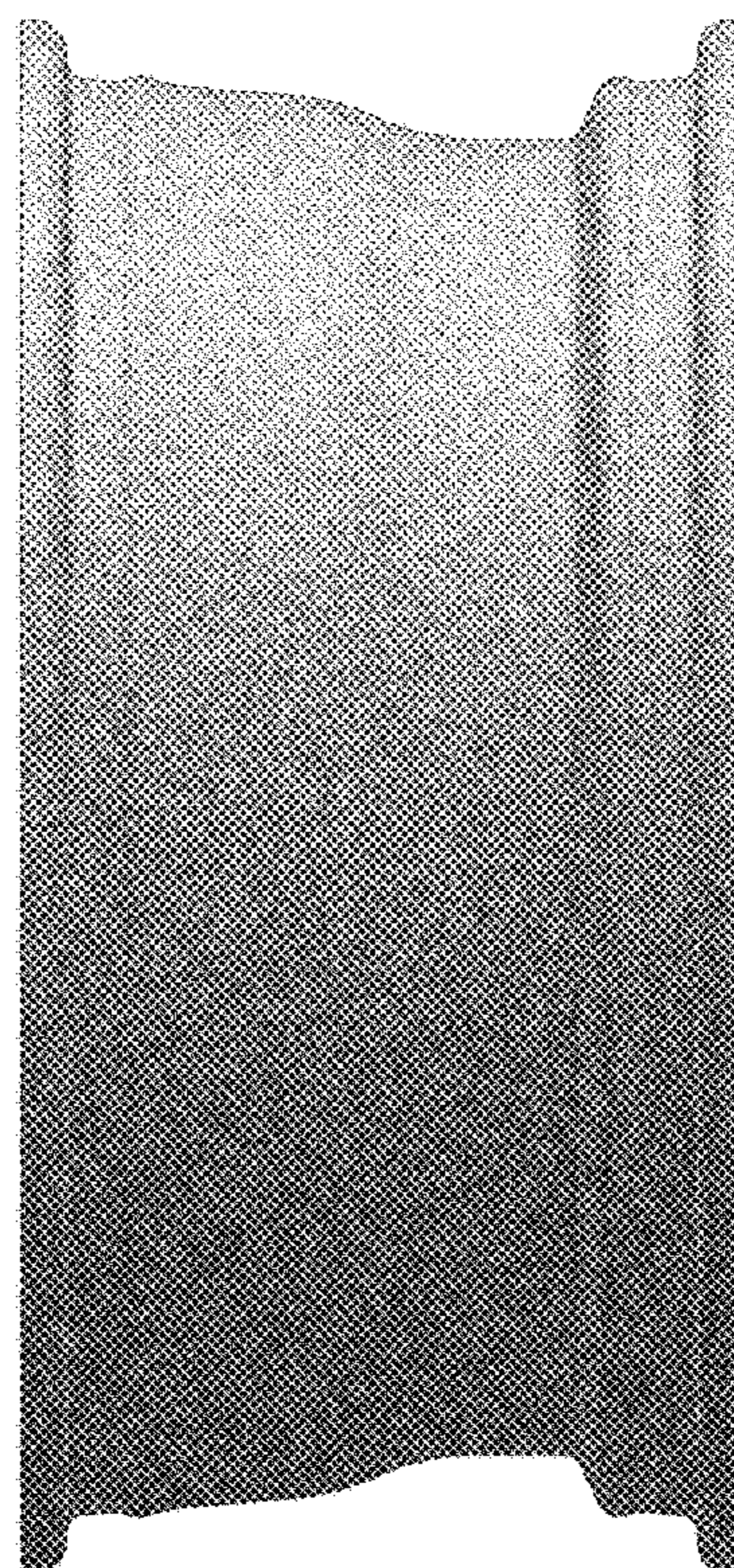

FIG. 4

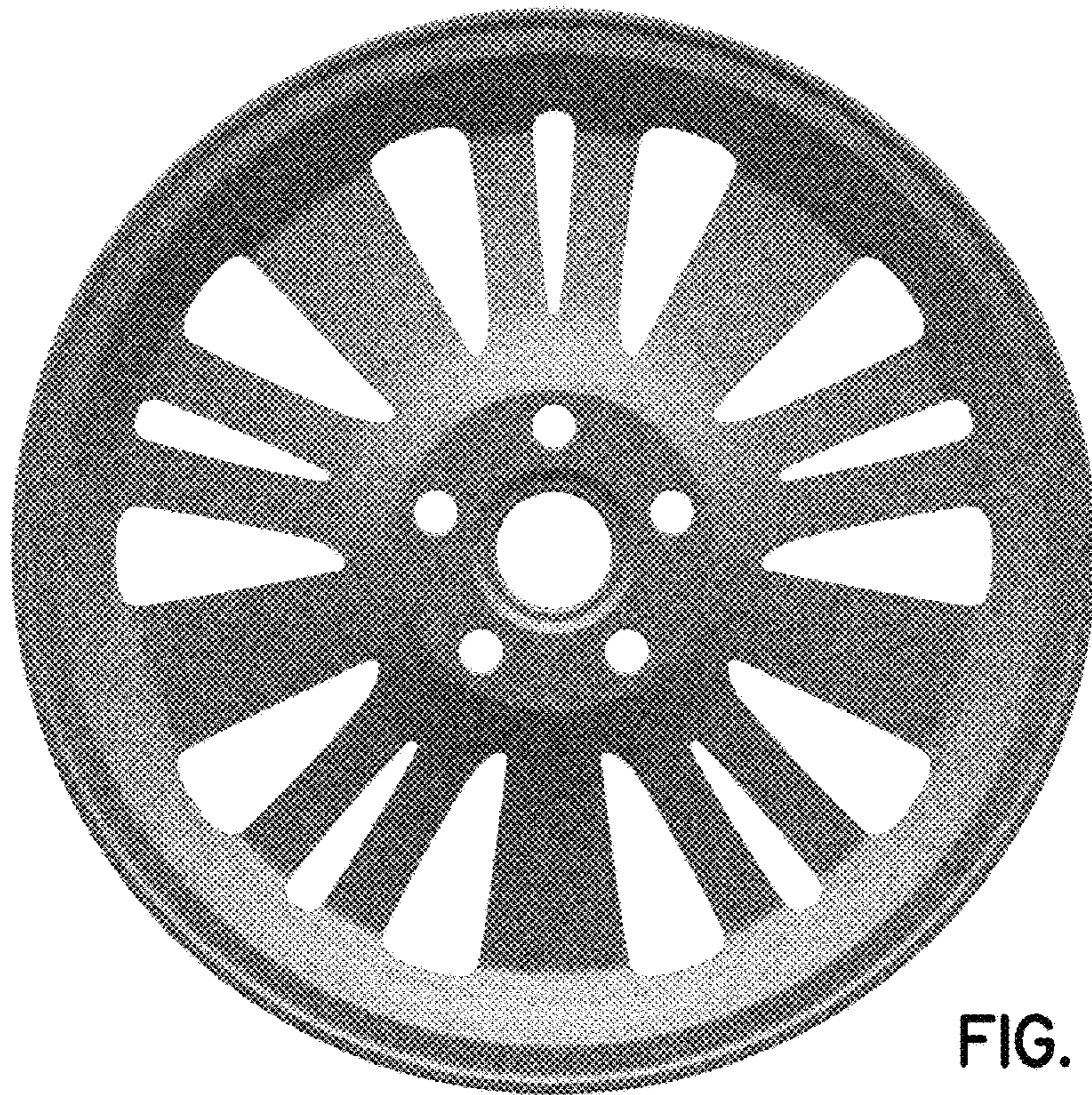

FIG. 5

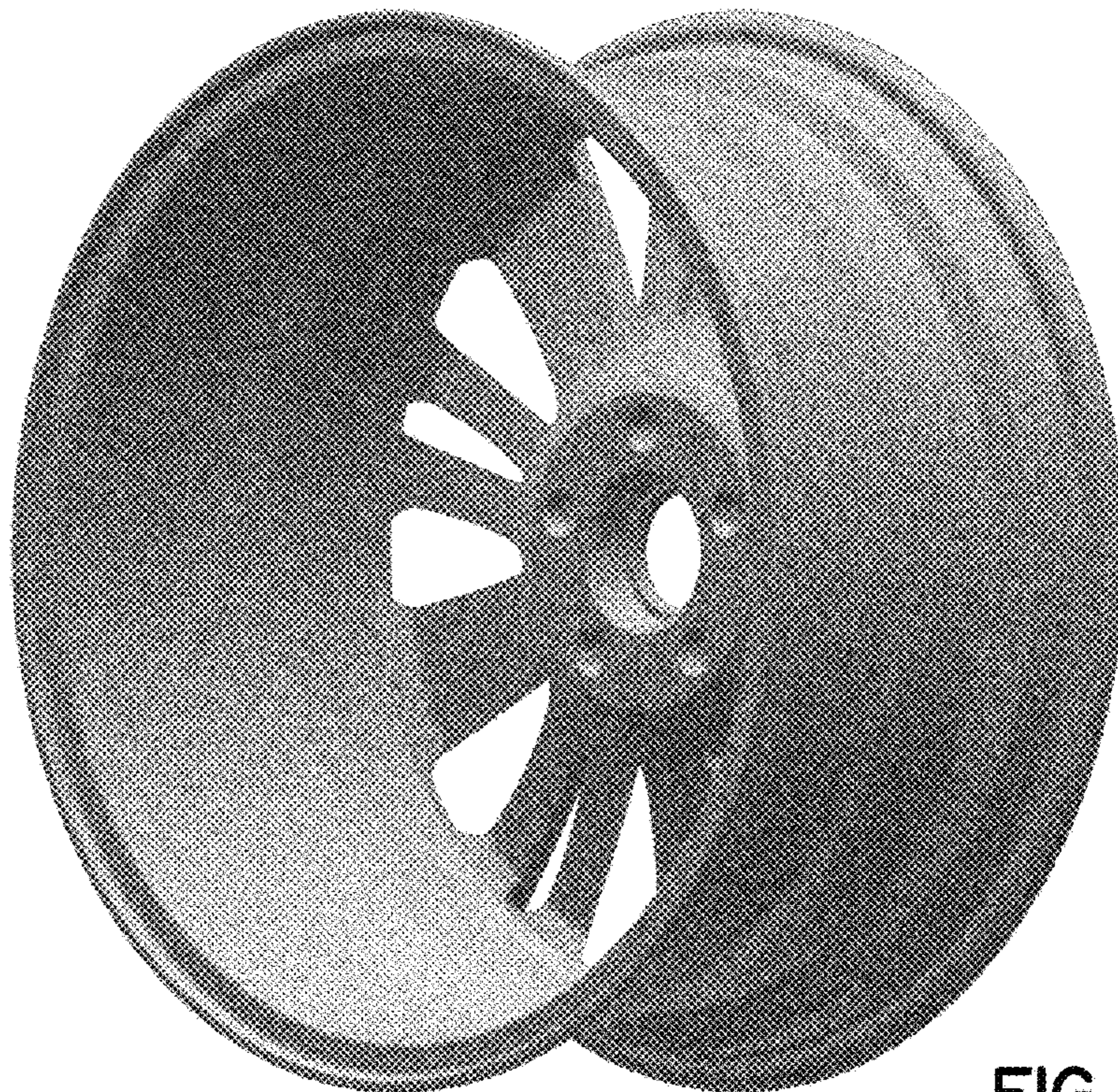

FIG. 6



FIG. 7



FIG. 8

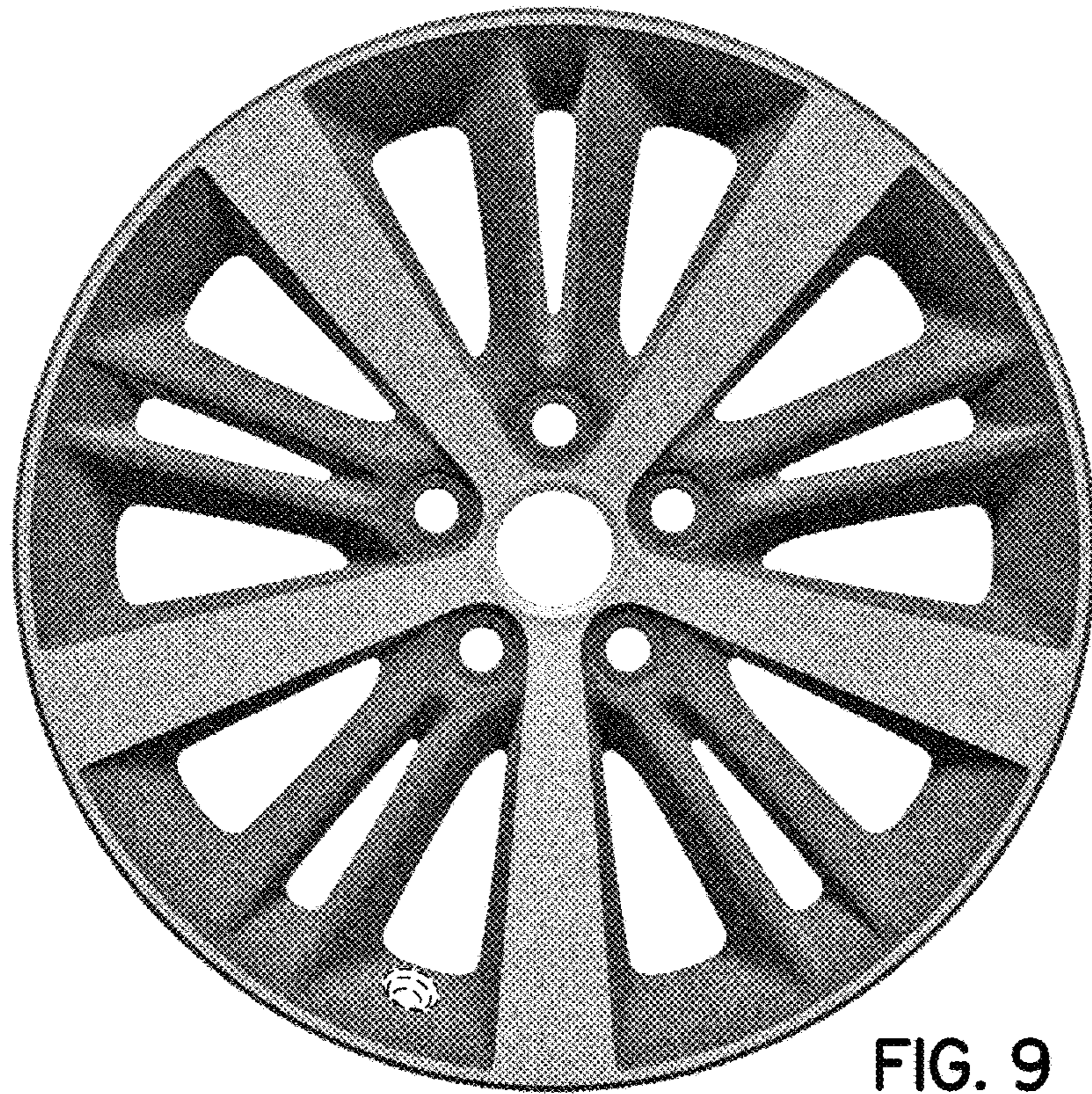

FIG. 9

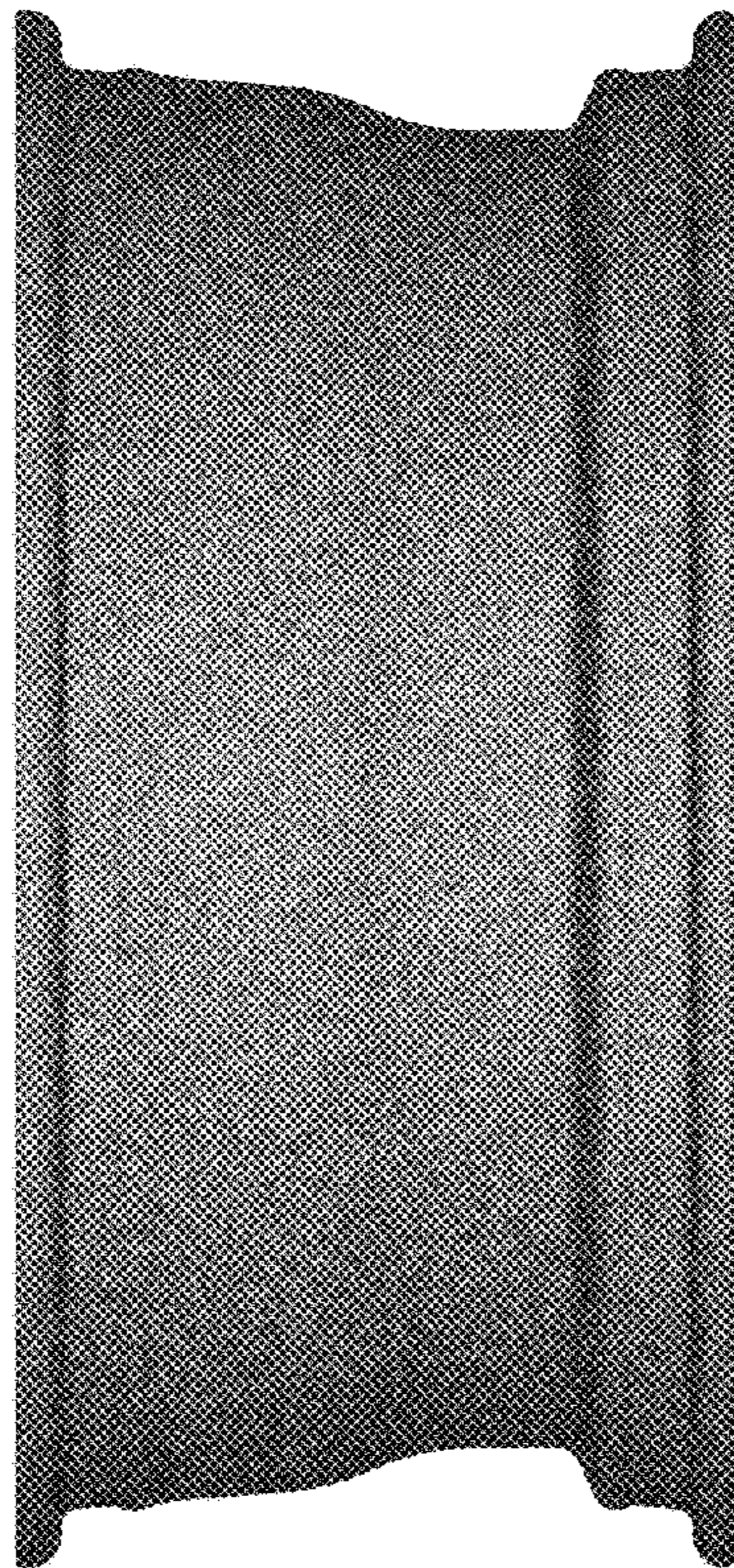

FIG. 10

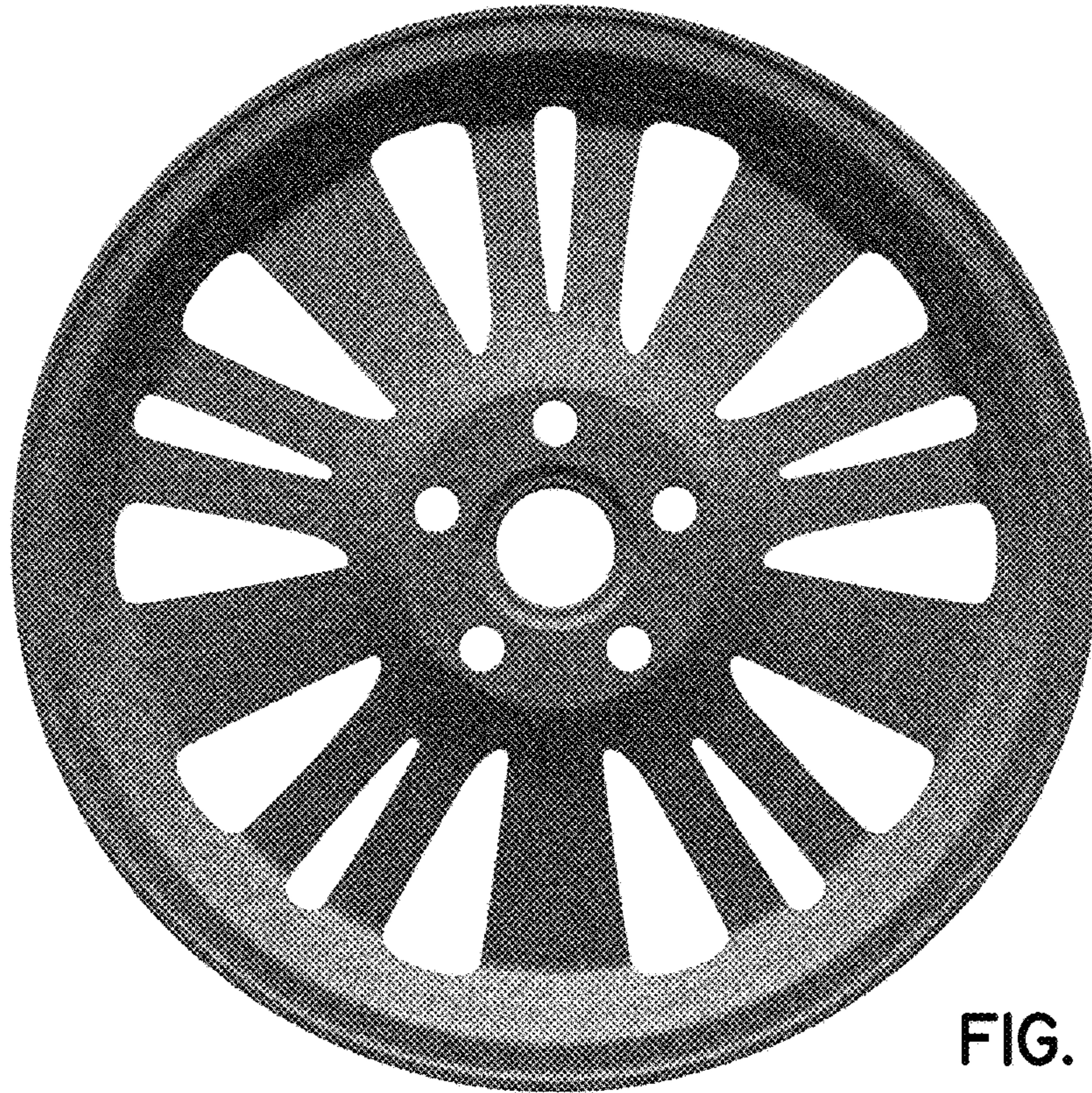

FIG. 11

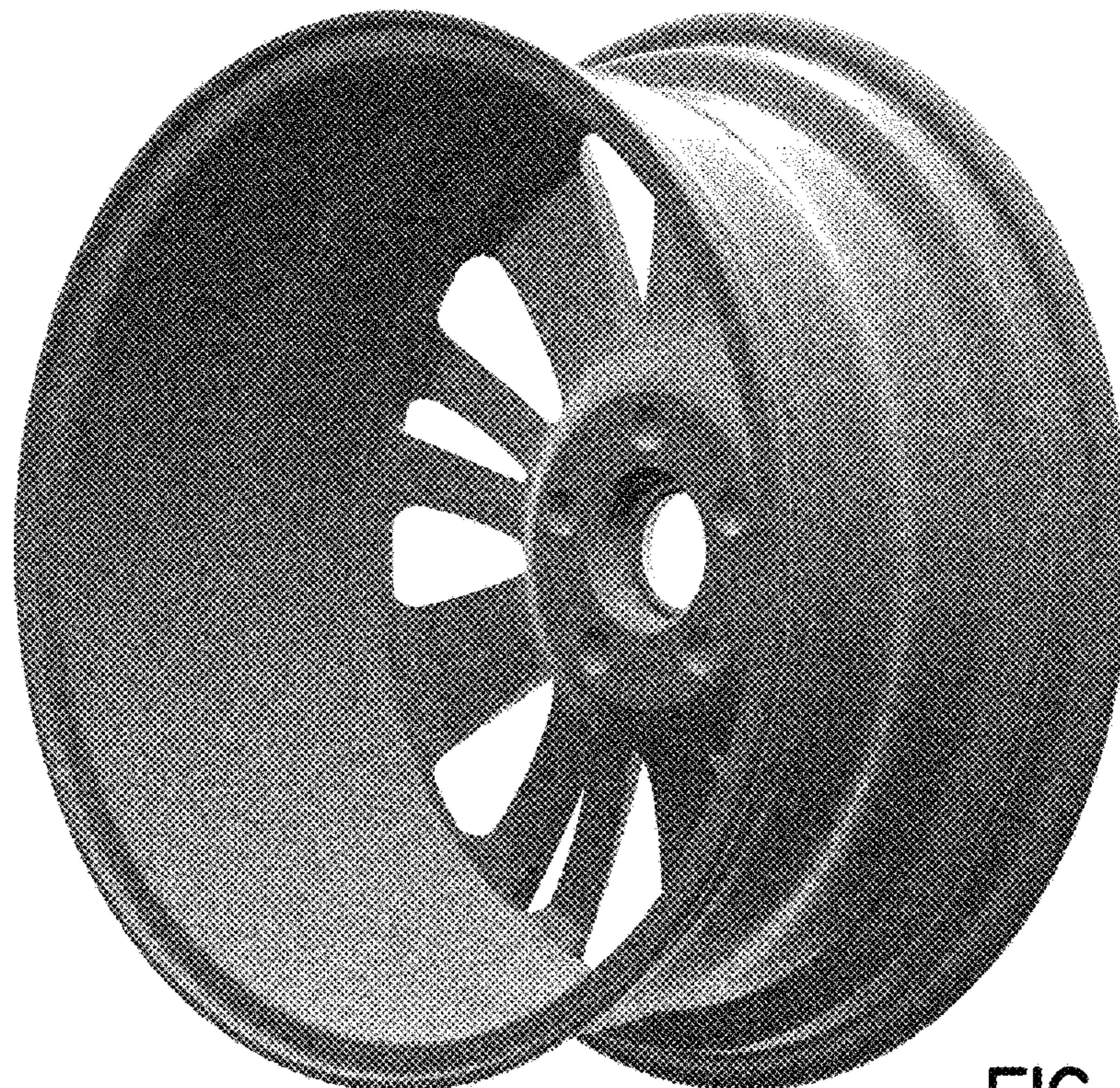

FIG. 12