



US00D832177S

(12) **United States Design Patent**  
**Grewer**

(10) **Patent No.:** **US D832,177 S**

(45) **Date of Patent:** **\*\* Oct. 30, 2018**

(54) **WHEEL**

(71) Applicant: **Jaguar Land Rover Limited**, Whitley,  
Coventry (GB)

(72) Inventor: **Dale Grewer**, Coventry (GB)

(73) Assignee: **Jaguar Land Rover Limited**, Whitley  
Coventry (GB)

(\*\*) Term: **15 Years**

(21) Appl. No.: **29/627,368**

(22) Filed: **Nov. 27, 2017**

**Related U.S. Application Data**

(62) Division of application No. 29/556,427, filed on Mar.  
1, 2016, now Pat. No. Des. 805,989.

(30) **Foreign Application Priority Data**

Sep. 4, 2015 (EM) ..... 002766766

(51) **LOC (11) Cl.** ..... **12-16**

(52) **U.S. Cl.**  
USPC ..... **D12/209**

(58) **Field of Classification Search**

USPC ..... D12/204–213  
CPC .... B60B 7/00; B60B 7/02; B60B 7/04; B60B  
7/01; B60B 7/06; B60B 3/02; B60B 3/04;  
B60B 3/06; B60B 3/10; B60B 1/00;  
B60B 1/08; B60B 1/10; B60B 1/12  
See application file for complete search history.

(56) **References Cited**

**U.S. PATENT DOCUMENTS**

D669,833 S \* 10/2012 Pollmann ..... D12/209  
D671,475 S \* 11/2012 Juergens ..... D12/209

D683,681 S \* 6/2013 Juergens ..... D12/209  
D685,709 S \* 7/2013 Hanaoka ..... D12/209  
D709,427 S \* 7/2014 Clottu ..... D12/209  
D715,209 S \* 10/2014 Tovey ..... D12/209  
D726,086 S \* 4/2015 Muntada Roura ..... D12/209  
D727,235 S \* 4/2015 Hans ..... D12/211  
D748,553 S \* 2/2016 Miyazawa ..... D12/209  
D754,047 S \* 4/2016 Frascella ..... D12/209  
D762,543 S \* 8/2016 Hara ..... D12/209  
D774,434 S \* 12/2016 Nakahara ..... D12/209  
D780,083 S \* 2/2017 Wheel ..... D12/209  
D781,763 S \* 3/2017 Webber ..... D12/209  
D805,989 S \* 12/2017 Grewer ..... D12/209  
D819,535 S \* 6/2018 Austin ..... D12/209

\* cited by examiner

*Primary Examiner* — Stacia A Cadmus

(74) *Attorney, Agent, or Firm* — Wood Herron & Evans  
LLP

(57) **CLAIM**

The ornamental design for a wheel, as shown and described.

**DESCRIPTION**

FIG. 1 is a front left perspective view of a wheel for a vehicle according to the present invention.  
FIG. 2 is a front view of the wheel shown in FIG. 1.  
FIG. 3 is a left side view thereof, the right side view being a mirror image thereof.  
FIG. 4 is a rear view thereof; and,  
FIG. 5 is a rear right perspective view thereof.  
The broken line showing of the valve stem and the valve stem hole are included for the purpose of illustrating environment and form no part of the claimed design.

**1 Claim, 3 Drawing Sheets**

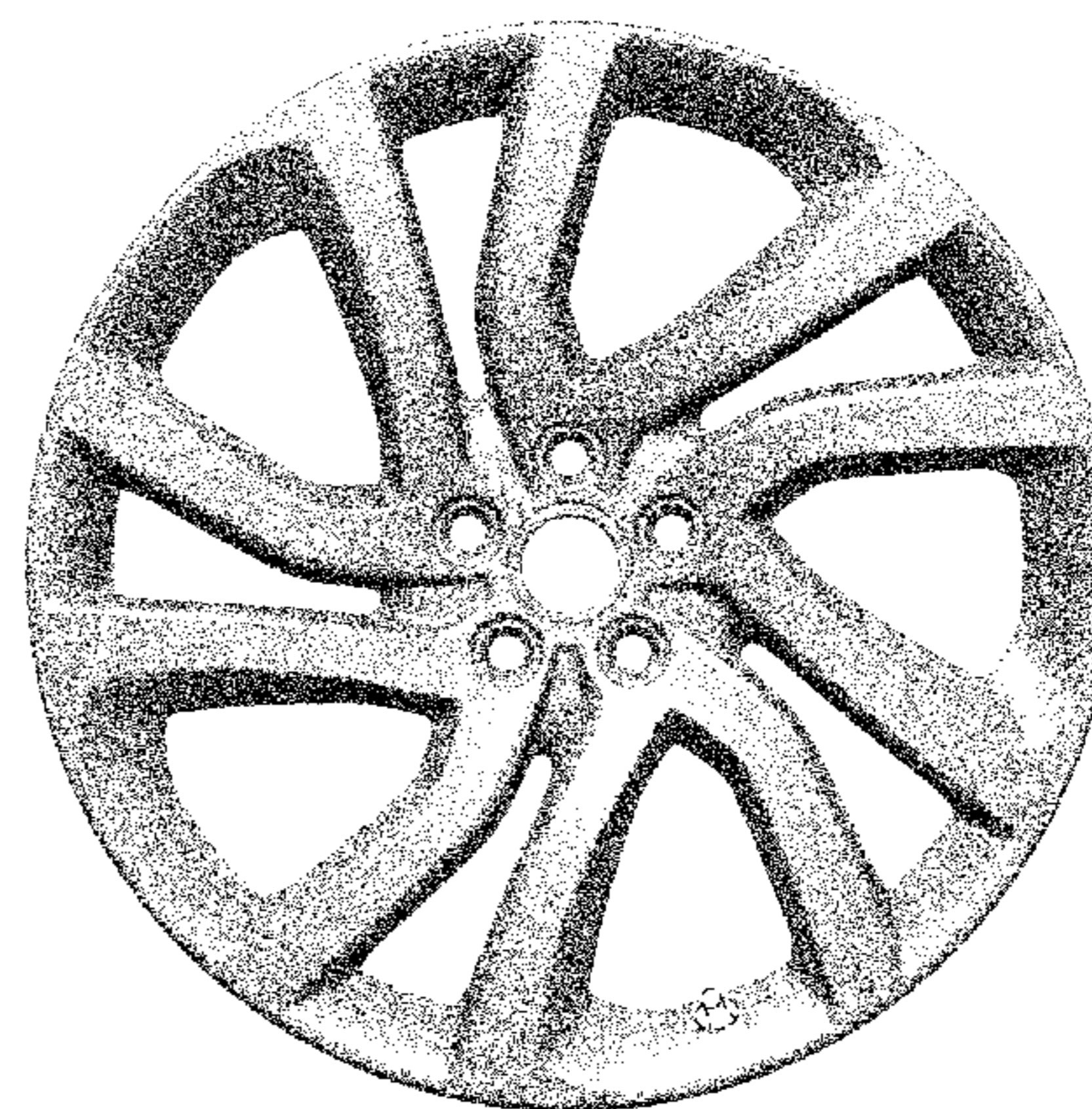



FIG. 1

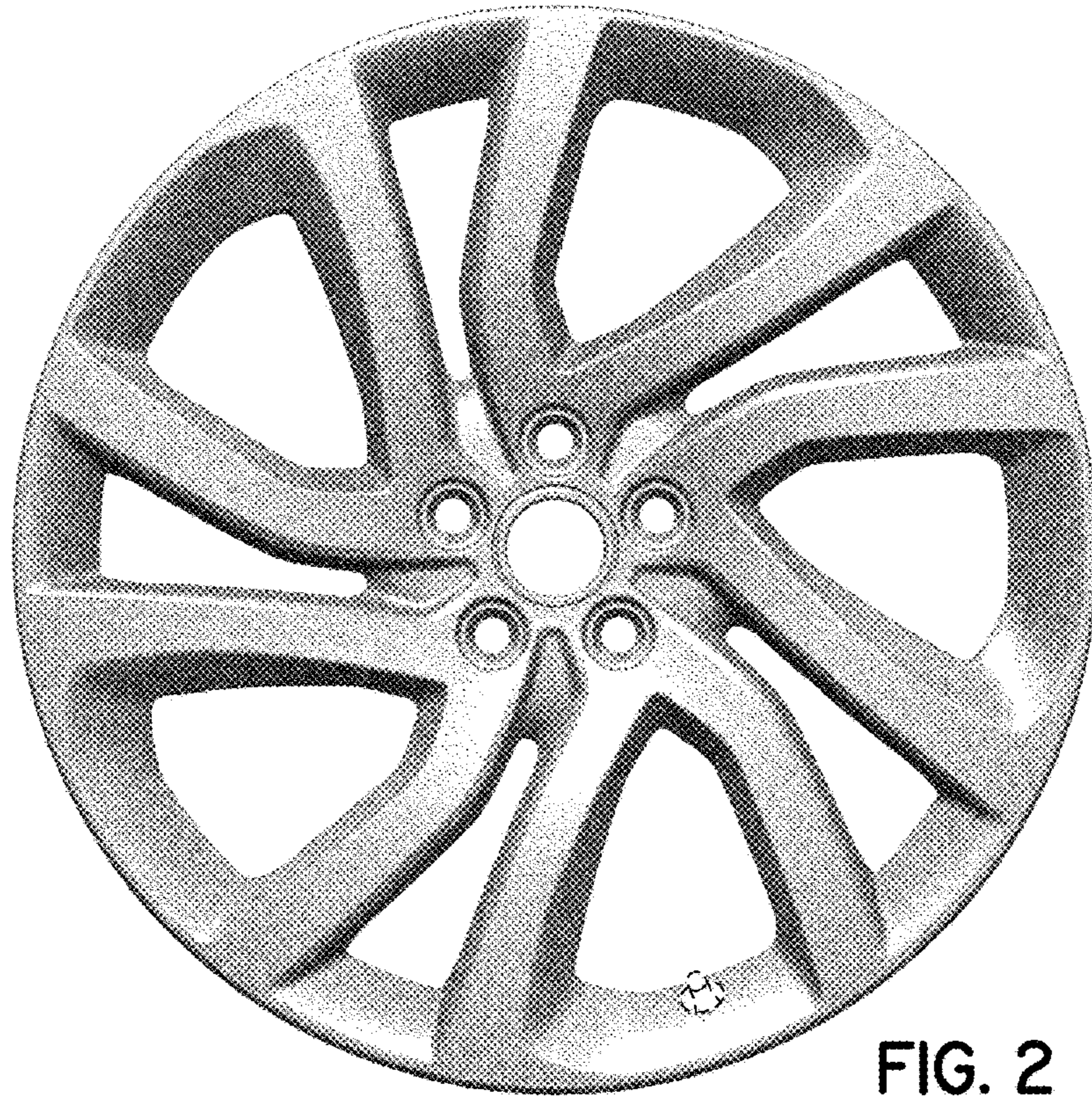

FIG. 2

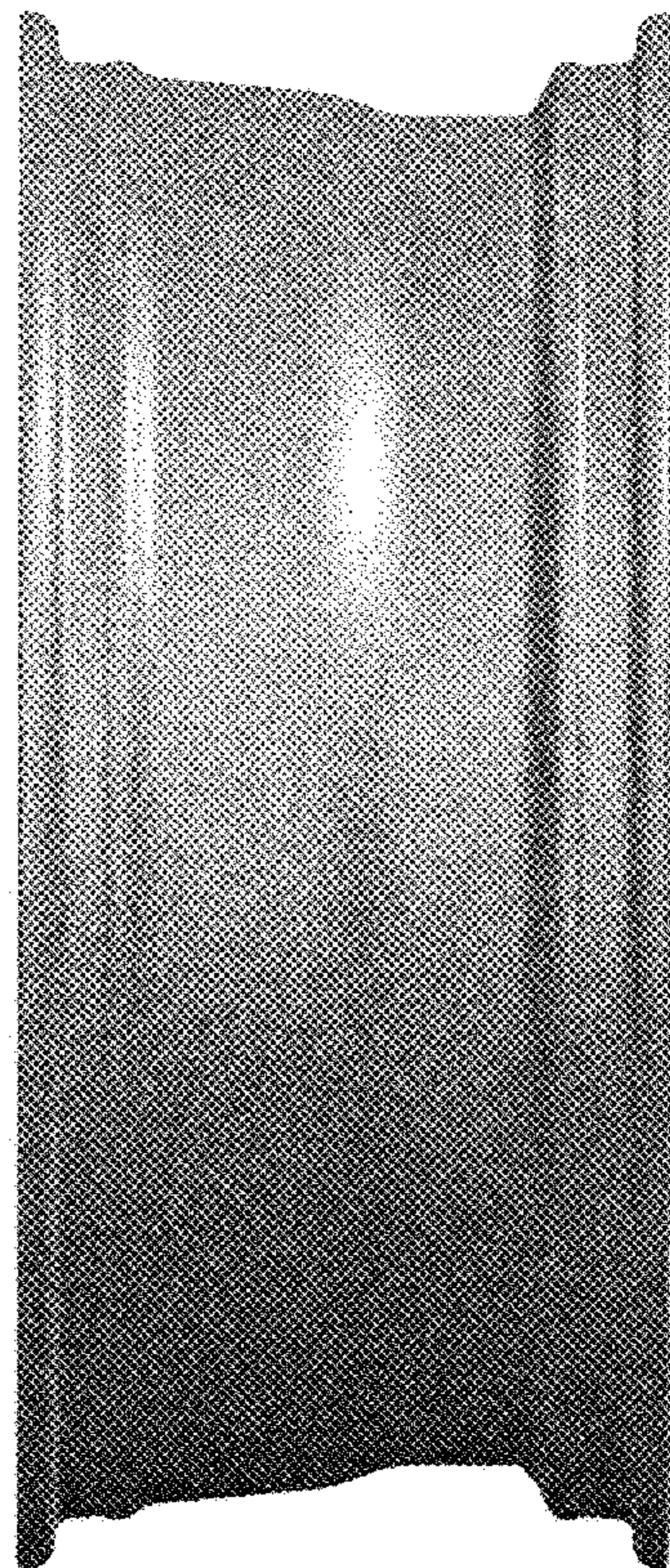

FIG. 3

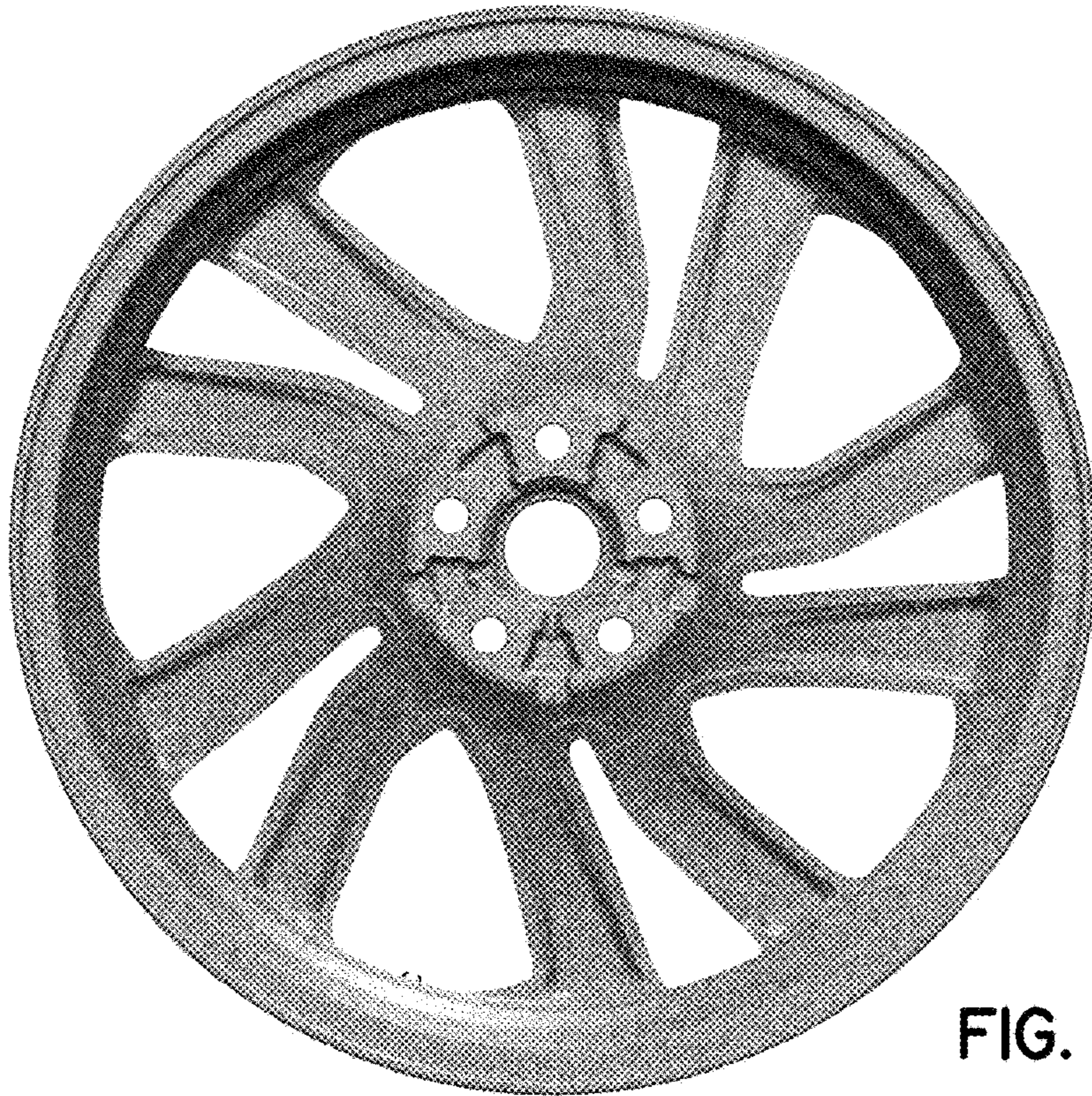

FIG. 4



FIG. 5