

US00D832169S

(12) **United States Design Patent**
Lee

(10) **Patent No.:** **US D832,169 S**
(45) **Date of Patent:** **** Oct. 30, 2018**

(54) **CAR WING ATTACHMENT**

D618,602 S * 6/2010 Ridzon D12/181
D768,808 S * 10/2016 Byrd D22/146

(71) Applicant: **Thomas Yu Lee**, Hillsborough, CA
(US)

* cited by examiner

(72) Inventor: **Thomas Yu Lee**, Hillsborough, CA
(US)

Primary Examiner — Abraham Bahta
(74) *Attorney, Agent, or Firm* — Christensen, Fonder,
Dardi & Herbert PLLC
(57) **CLAIM**

(**) Term: **15 Years**

The ornamental design for a car wing attachment, as shown and described.

(21) Appl. No.: **29/610,190**

DESCRIPTION

(22) Filed: **Jul. 10, 2017**

(51) **LOC (11) Cl.** **12-08**

(52) **U.S. Cl.**
USPC **D12/190**

(58) **Field of Classification Search**
USPC D12/319, 330-342, 345, 181, 191, 400,
D12/169; D21/436, 447; 160/131-132;
280/848, 727; 296/180.1, 180.2, 91
CPC . F03D 1/0633; F03D 1/00; F03D 3/00; F03D
3/04; B62D 35/00; B62D 35/005; B62D
35/007; B62D 35/008
See application file for complete search history.

FIG. 1 is a first perspective view of a car wing attachment showing the claimed design;
FIG. 2 is second perspective view of FIG. 1;
FIG. 3 is third perspective view of FIG. 1;
FIG. 4 is a front elevational view of FIG. 1;
FIG. 5 is a rear elevational view of FIG. 1;
FIG. 6 is a left side elevational view of FIG. 1;
FIG. 7 is a right side elevational view of FIG. 1;
FIG. 8 is a top plan view of FIG. 1;
FIG. 9 is a bottom plan view of FIG. 1;
FIG. 10 is a referential cross-sectional view taken from line 10-10 in FIG. 8;
FIG. 11 is a referential cross-sectional view taken from line 11-11 in FIG. 8;
FIG. 12 is a perspective referential view of a pair of car wing attachments mounted on a car tail; and,
FIG. 13 is another perspective referential view of a pair of car wing attachments in use.
The broken lines in the figures represent environment and portions of the article which form no part of the claimed design.

(56) **References Cited**

U.S. PATENT DOCUMENTS

D376,341 S * 12/1996 Kovach D12/181
D435,817 S * 1/2001 Lai D12/181
D445,742 S * 7/2001 Tampi D12/181
D473,831 S * 4/2003 Saleen D12/181
D487,040 S * 2/2004 Iwata D12/181
D491,121 S * 6/2004 Yokomaku D12/181
D547,707 S * 7/2007 Kulla D12/181
D559,750 S * 1/2008 Kulla D12/181

1 Claim, 13 Drawing Sheets

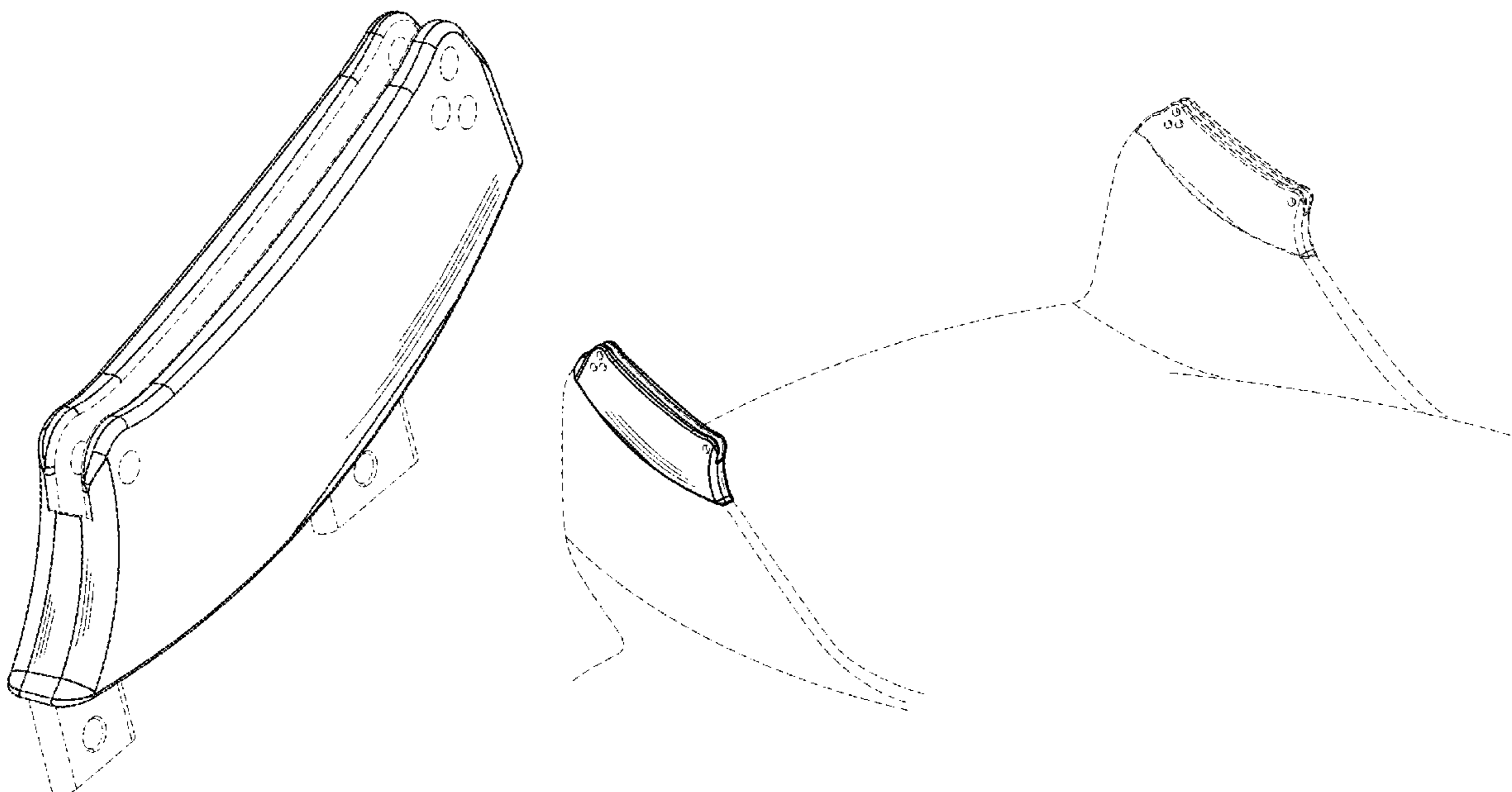

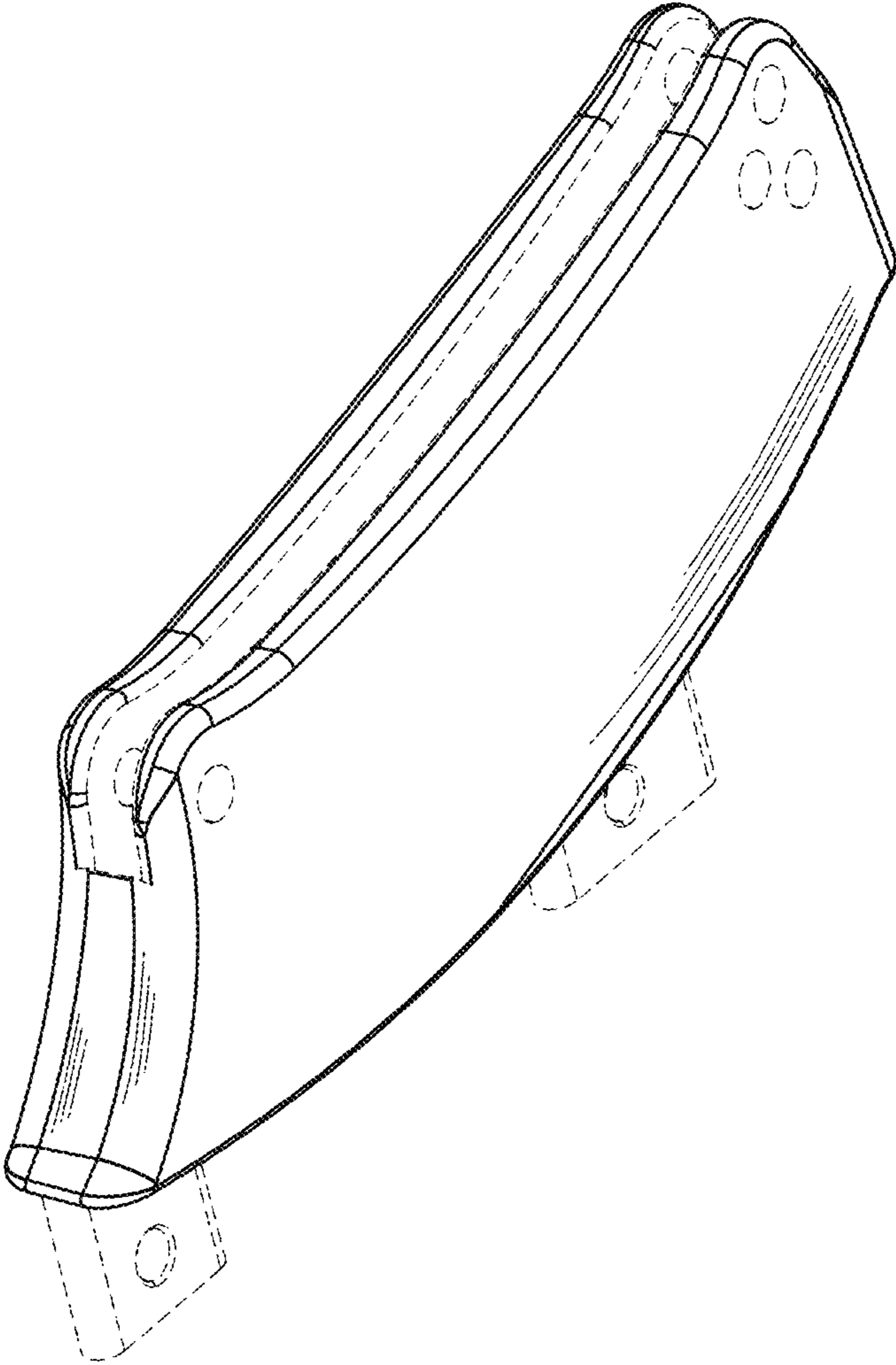

FIG.1

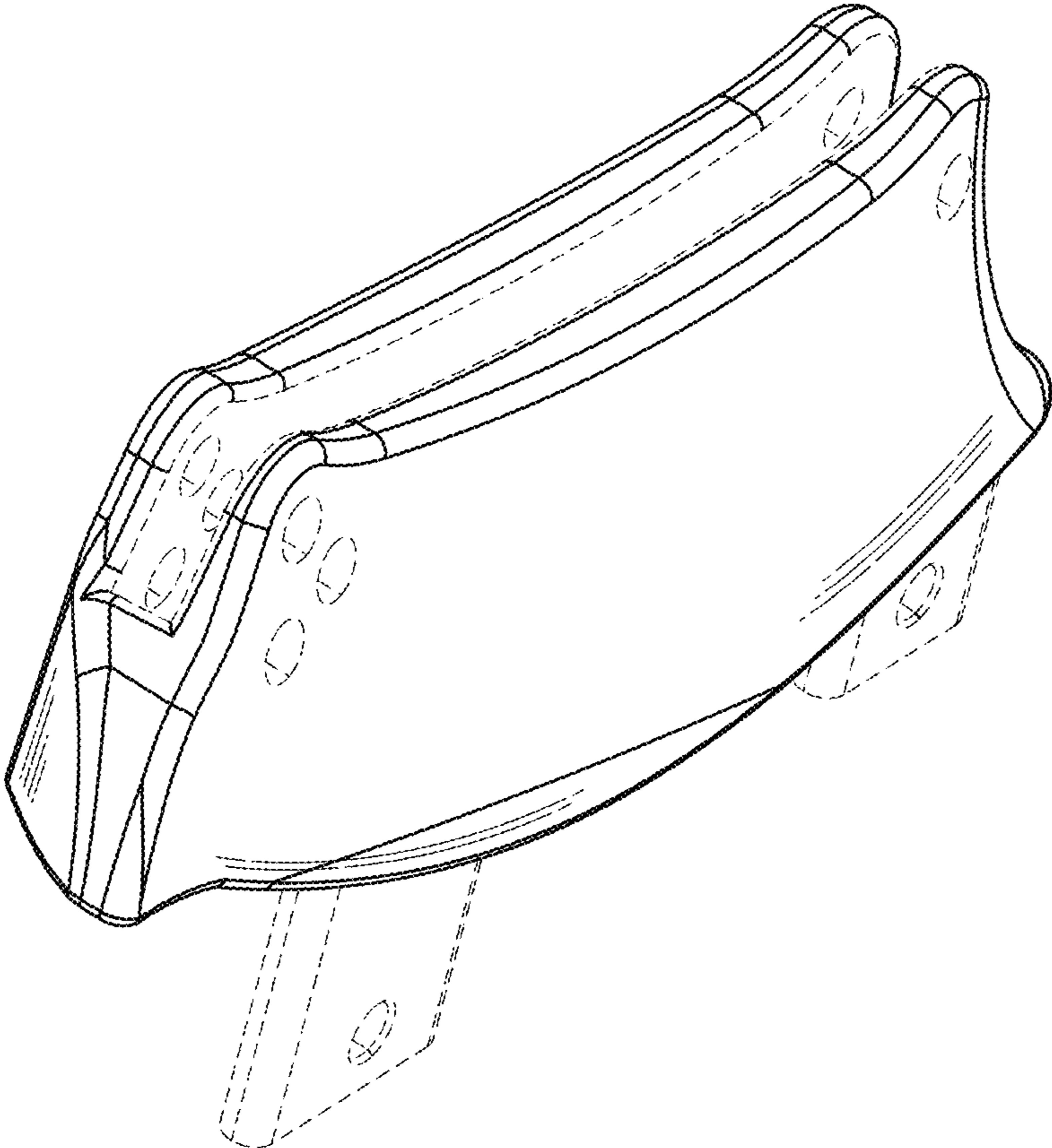

FIG.2

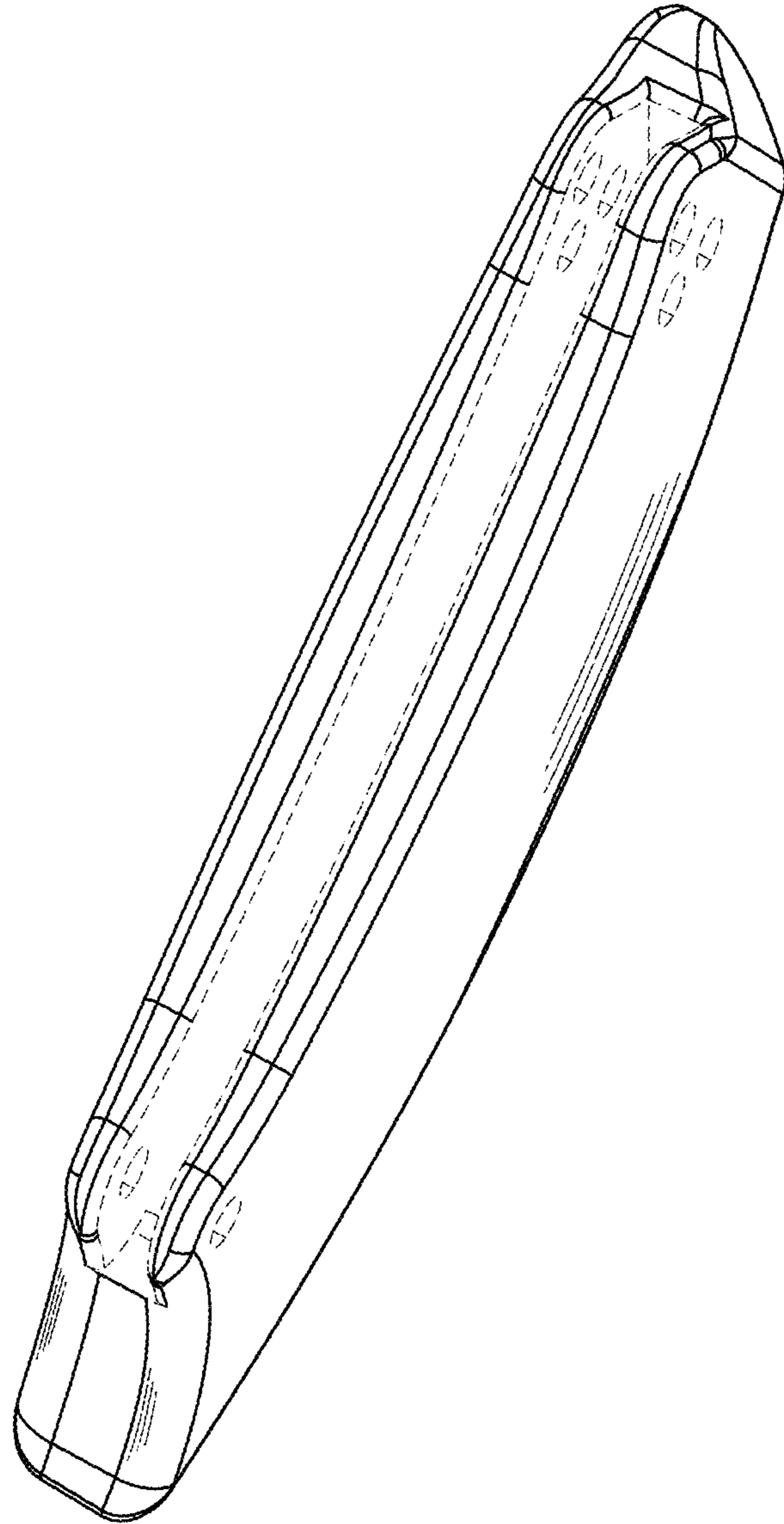

FIG.3

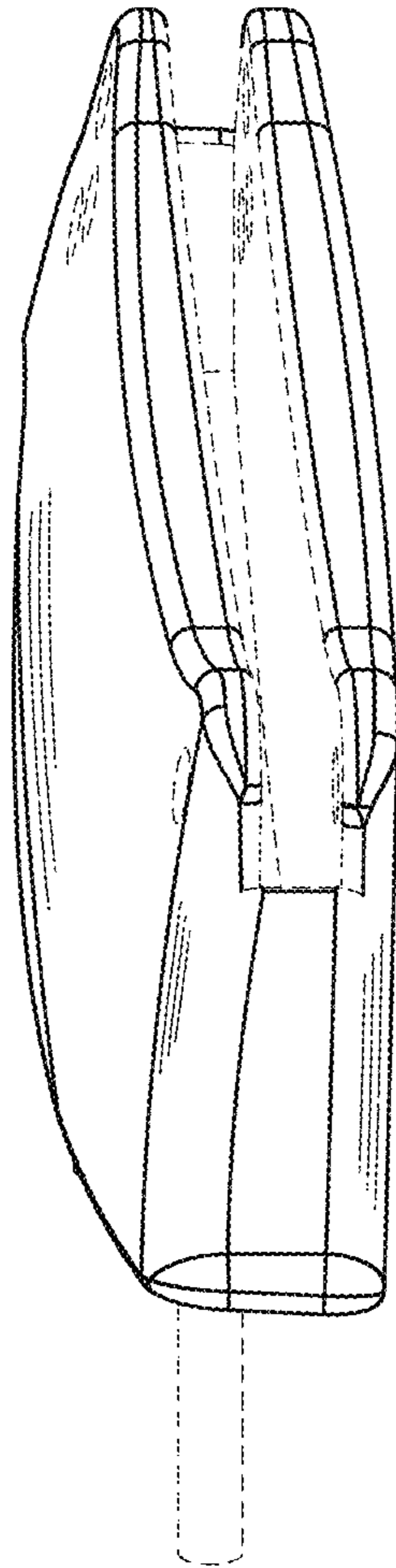

FIG. 4

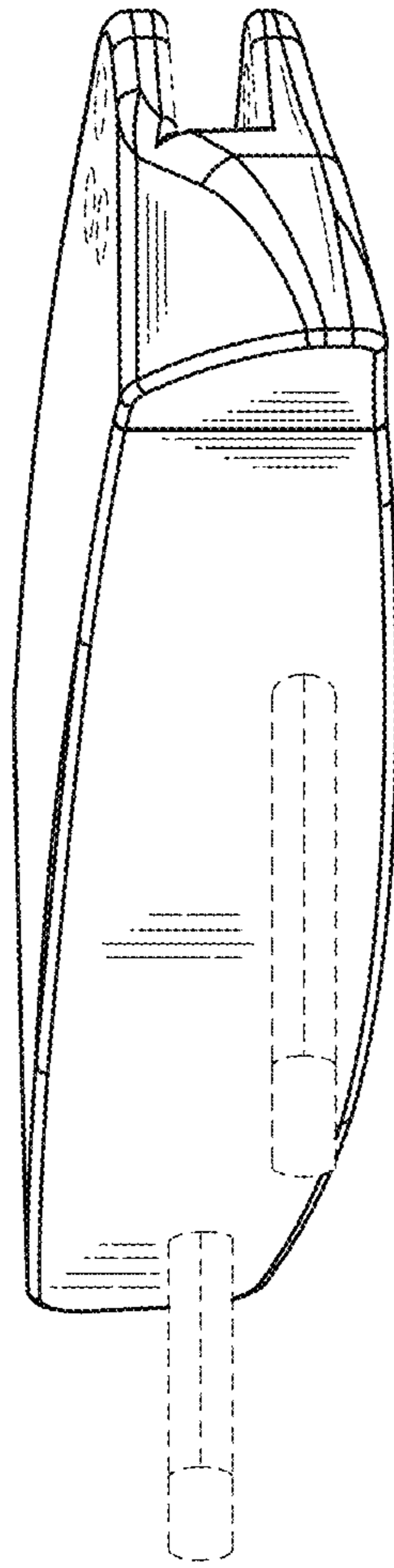

FIG.5

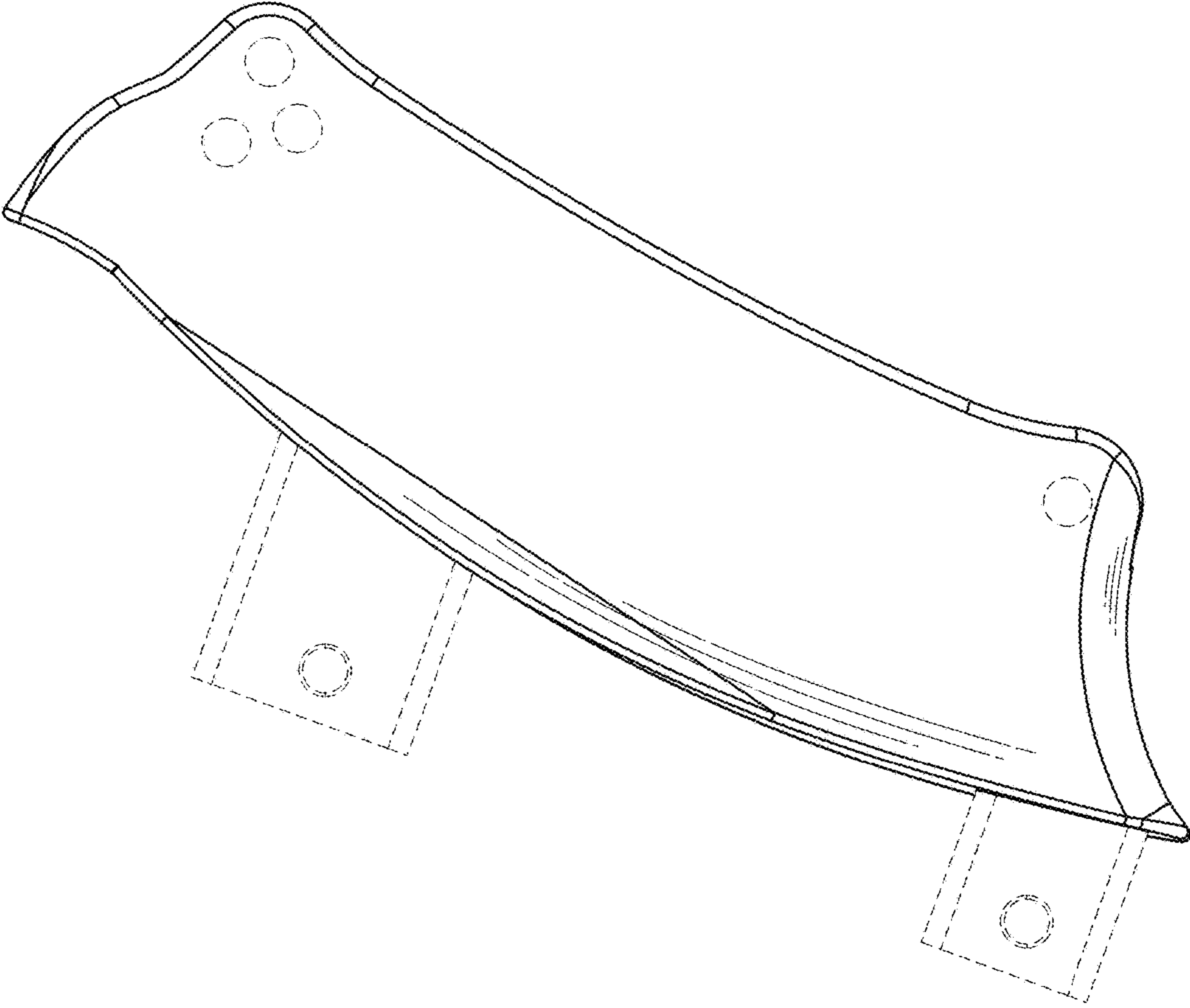

FIG.6

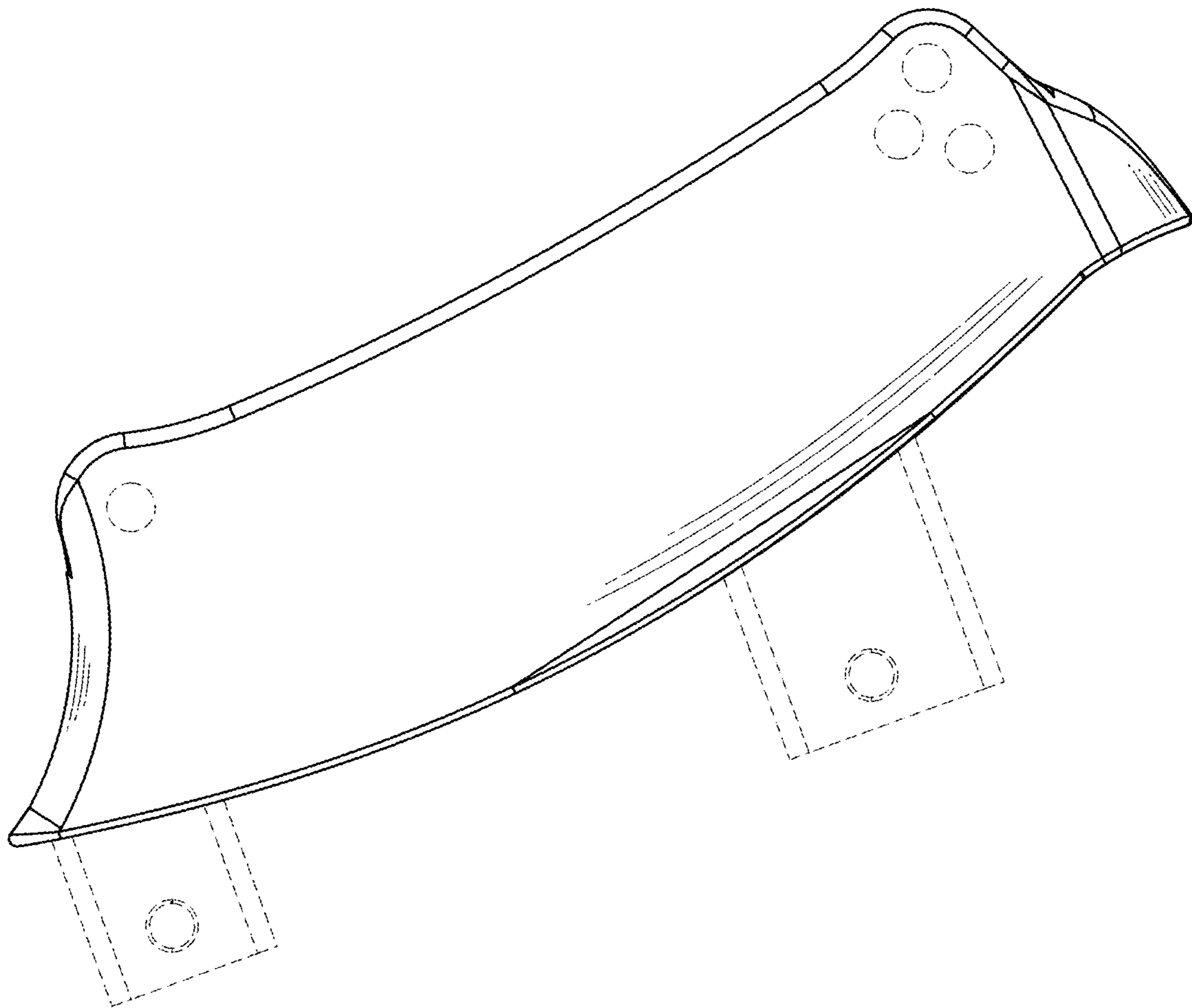

FIG.7

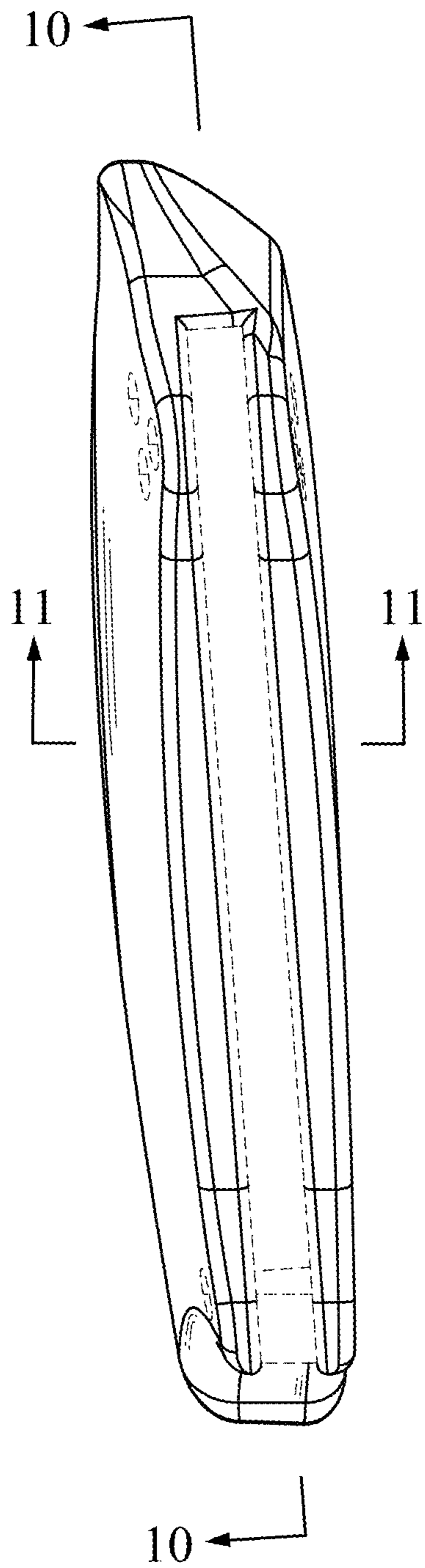

FIG.8

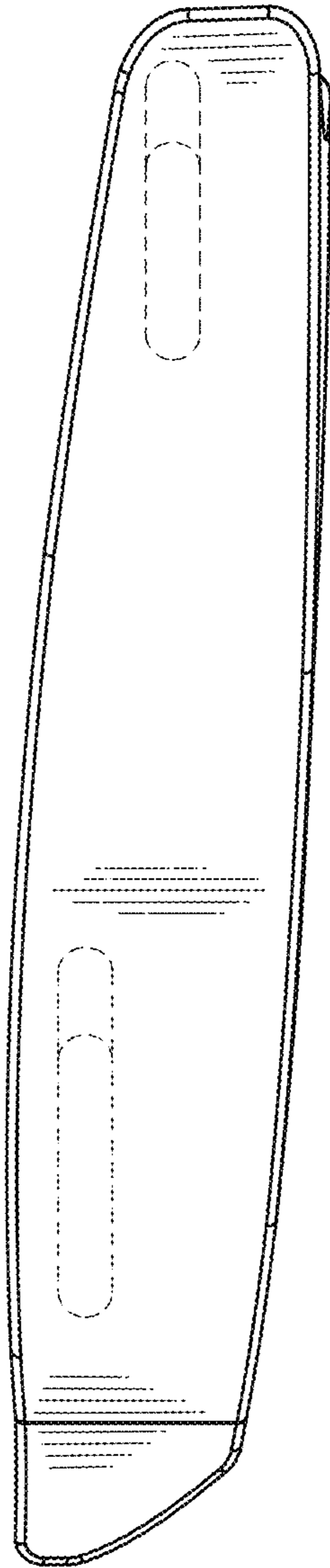

FIG.9

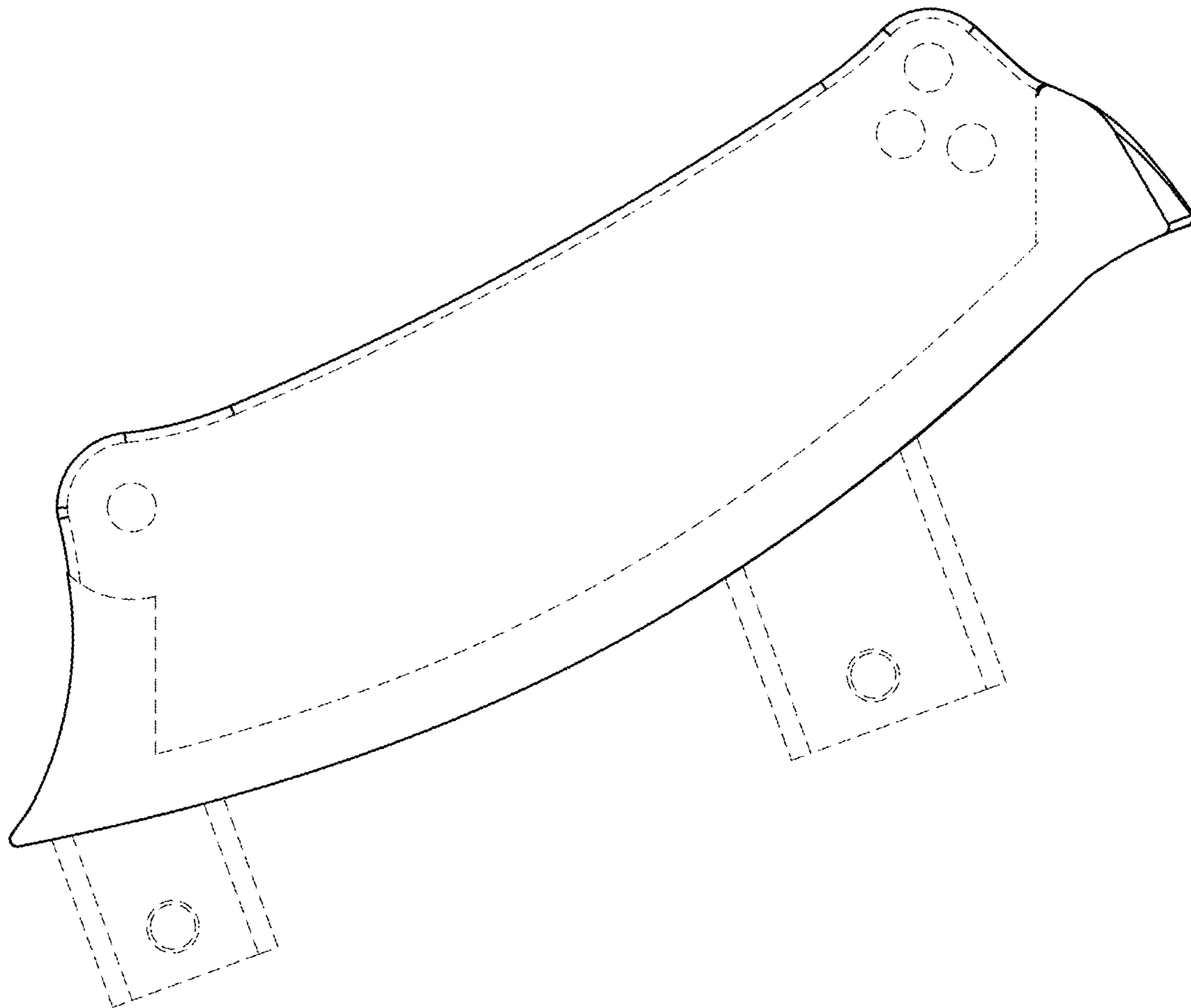

FIG.10

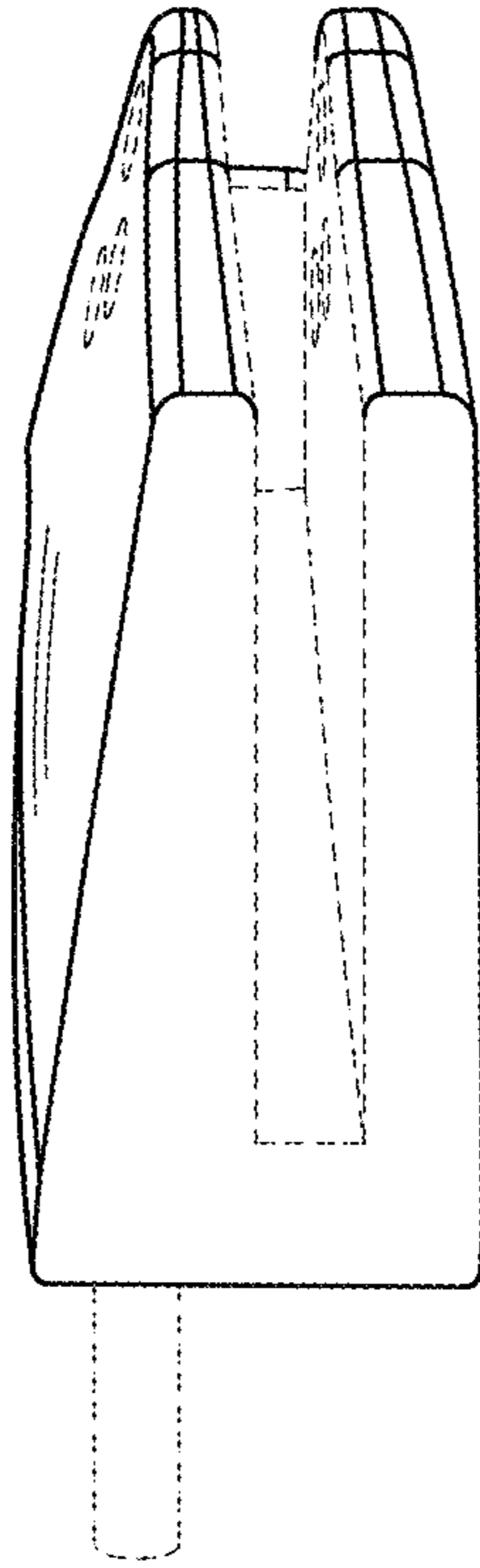

FIG. 11

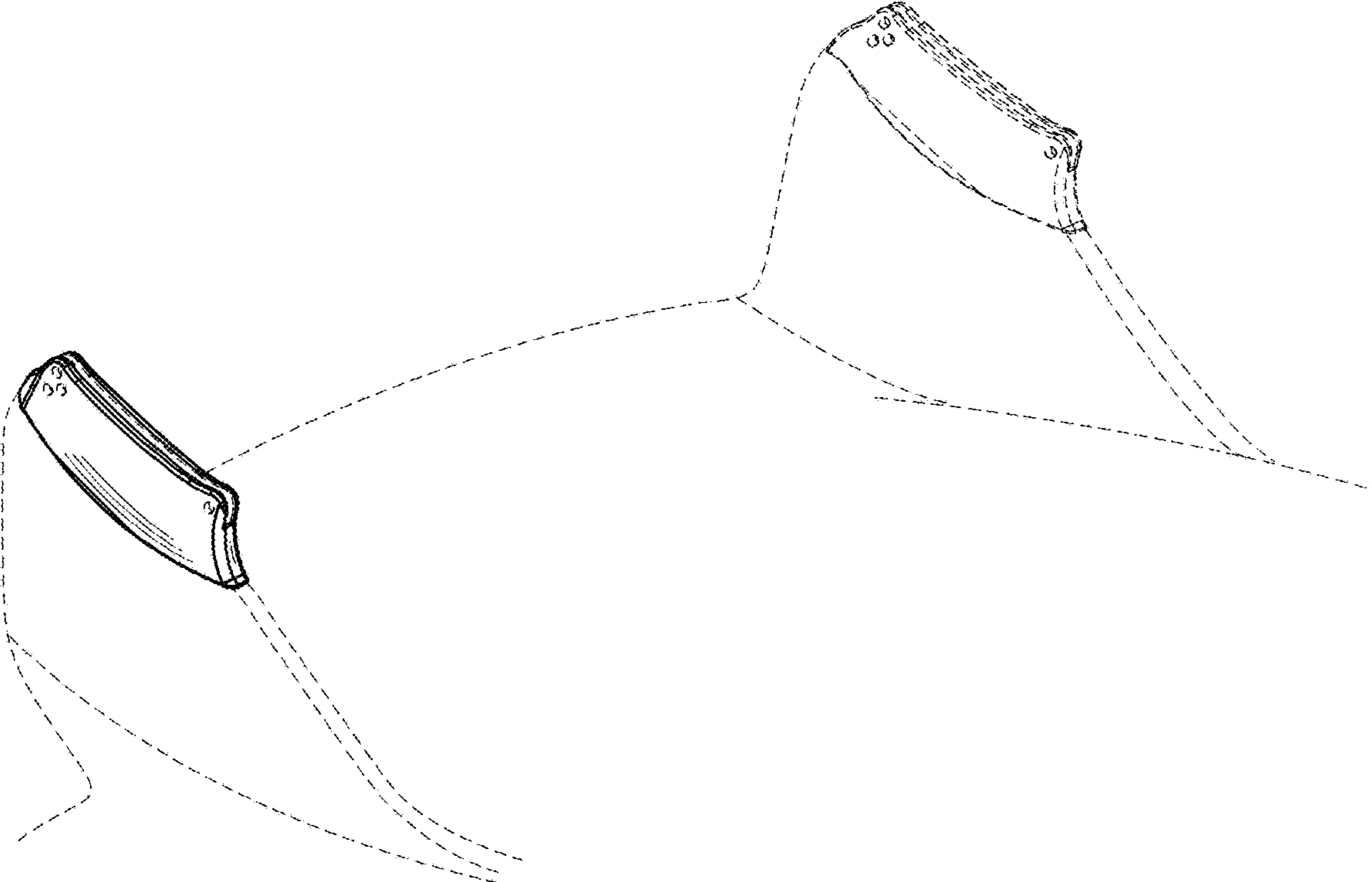

FIG.12

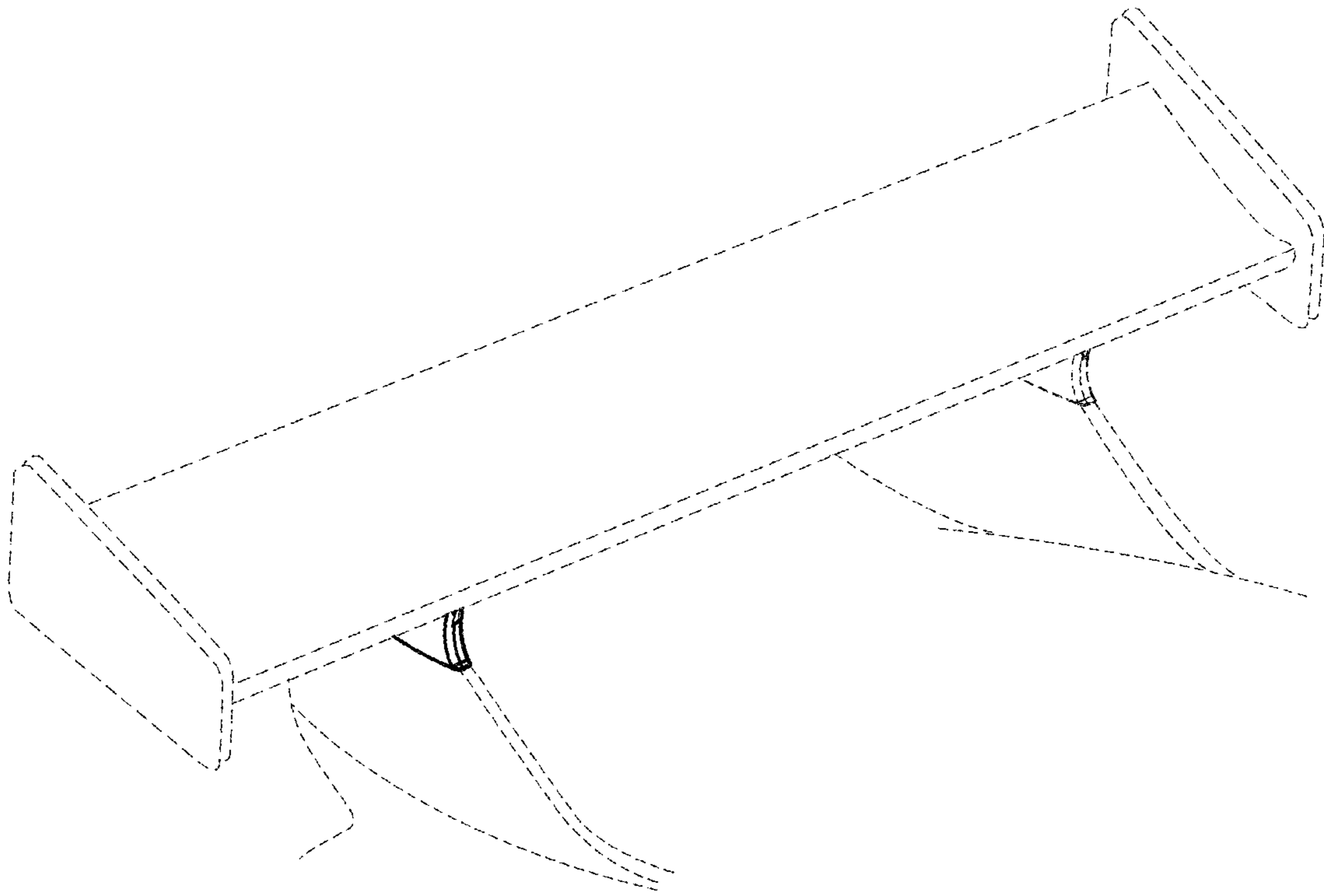

FIG.13