



US00D832163S

(12) **United States Design Patent**
Smith

(10) **Patent No.:** **US D832,163 S**

(45) **Date of Patent:** **** Oct. 30, 2018**

(54) **HANDLEBAR**

(71) Applicant: **Robert Smith**, Spicewood, TX (US)

(72) Inventor: **Robert Smith**, Spicewood, TX (US)

(**) Term: **15 Years**

(21) Appl. No.: **29/607,566**

(22) Filed: **Jun. 14, 2017**

(51) **LOC (11) Cl.** **12-11**

(52) **U.S. Cl.**
USPC **D12/178**

(58) **Field of Classification Search**
USPC D12/111, 114, 178; D8/303
CPC B62K 19/16; B62K 21/12; B62K 21/18;
B62K 21/125; B62K 23/06
See application file for complete search history.

(56) **References Cited**

U.S. PATENT DOCUMENTS

D223,072 S *	3/1972	Pawsat et al.	D12/178
D224,696 S *	8/1972	Pawsat et al.	74/551.1
5,257,552 A *	11/1993	Boyer	B62K 21/12 74/551.1
D342,475 S *	12/1993	Haro	D12/178
D425,463 S *	5/2000	Clarkson	D12/178
D458,566 S *	6/2002	Carlini	D12/178
D477,798 S *	7/2003	Bean	D12/178
D496,893 S *	10/2004	Sieve	D12/178
D497,858 S *	11/2004	Fabian	D12/178
D542,197 S *	5/2007	Carlini	D12/178
7,350,437 B2 *	4/2008	Mangano	B62K 21/12 74/551.1
D572,181 S *	7/2008	Lujan	D12/178
D604,212 S *	11/2009	Carlini	D12/178
D612,307 S *	3/2010	Lujan	D12/178
D621,755 S *	8/2010	Carlini	D12/178

D629,343 S *	12/2010	Carlini	D12/178
D639,211 S *	6/2011	Lujan	D12/110
D658,098 S *	4/2012	Plainfield	D12/178
D664,079 S *	7/2012	Lujan	D12/178
D687,753 S *	8/2013	Carlini	D12/178
D689,418 S *	9/2013	Menefee	D12/178
D725,455 S *	3/2015	Carlini	D8/303
D726,607 S *	4/2015	Rickard	D12/178
D727,808 S *	4/2015	Heinz	D12/178
2012/0210821 A1 *	8/2012	Carlini	B62K 19/30 74/551.8

* cited by examiner

Primary Examiner — Darlington Ly

(74) *Attorney, Agent, or Firm* — Vincent J. Allen; Krista Y. Chan; Carstens & Cahoon, LLP

(57) **CLAIM**

The ornamental design for a handlebar, as shown and described.

DESCRIPTION

FIG. 1 is a front perspective view of a handlebar showing my new design;
FIG. 2 is a front elevation view thereof;
FIG. 3 is a rear elevation view thereof;
FIG. 4 is a right side elevation view thereof;
FIG. 5 is a left side elevation view thereof;
FIG. 6 is a top plan view thereof; and,
FIG. 7 is a bottom plan view thereof.

The broken lines in the drawings illustrate portions of the handlebar that form no part of the claimed design. Additionally, the handlebar is shown with symbolic breaks in some of its lengths. The appearance of any portion of the article between these break lines forms no part of the claimed design.

1 Claim, 6 Drawing Sheets

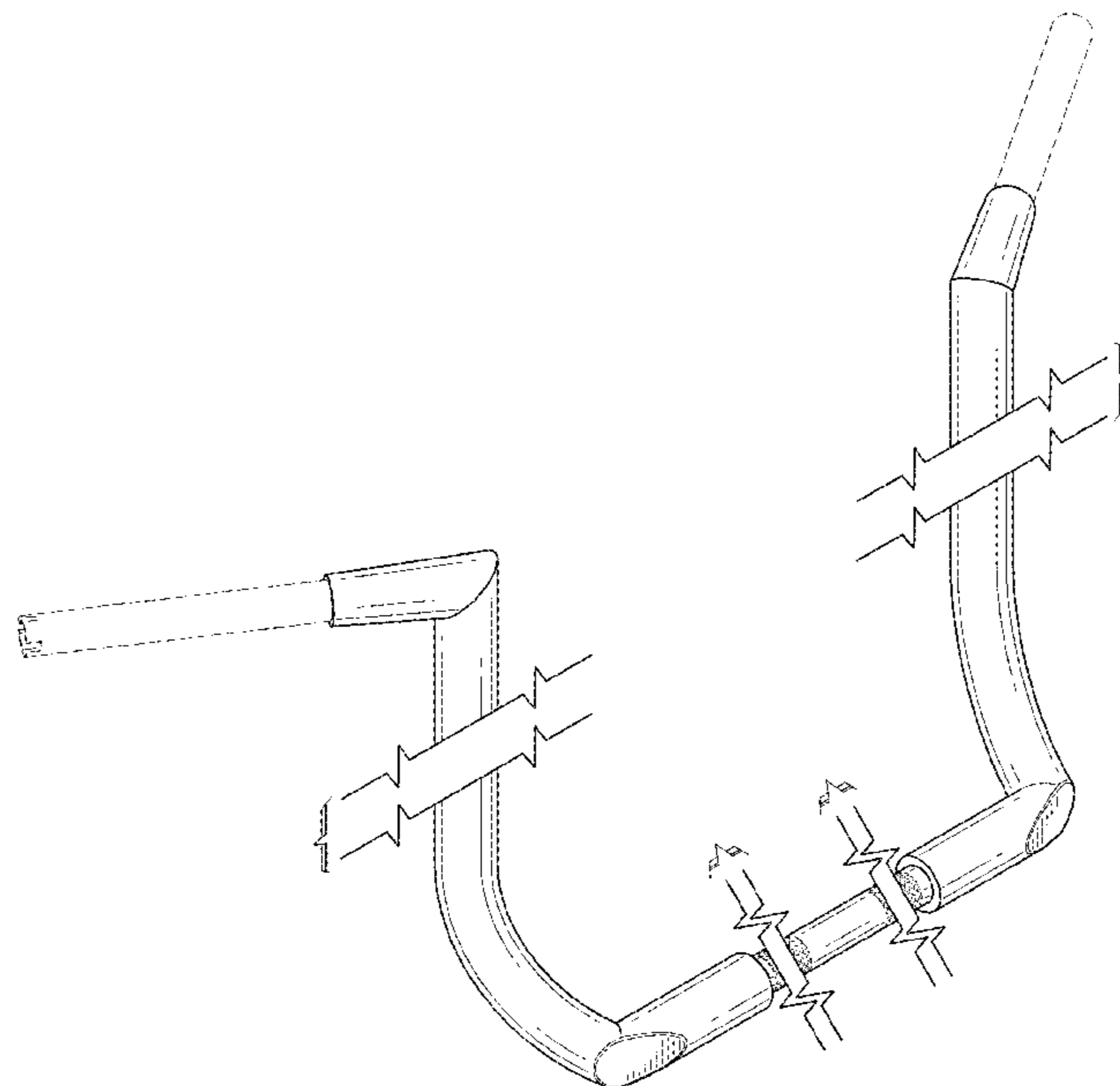

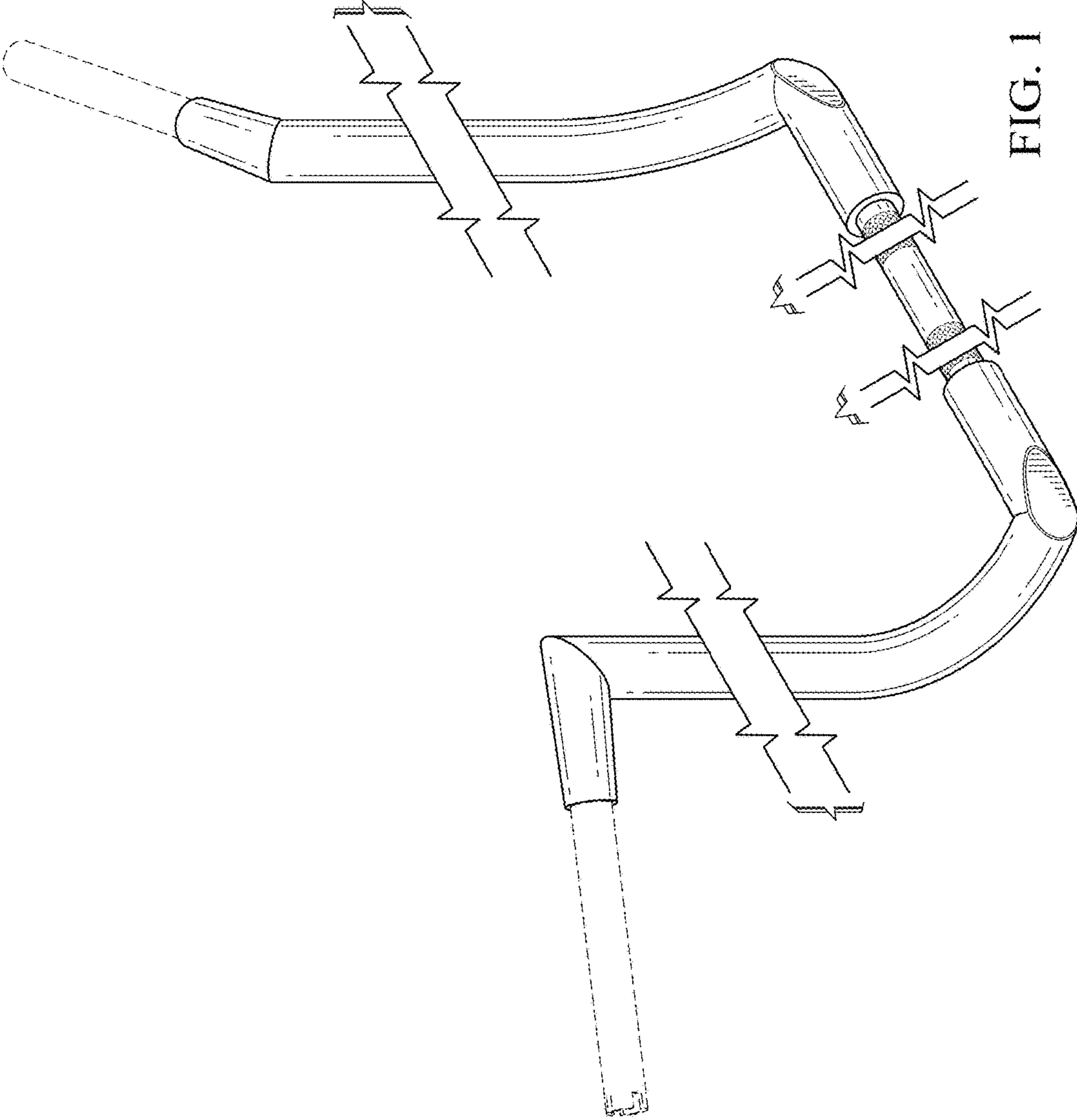

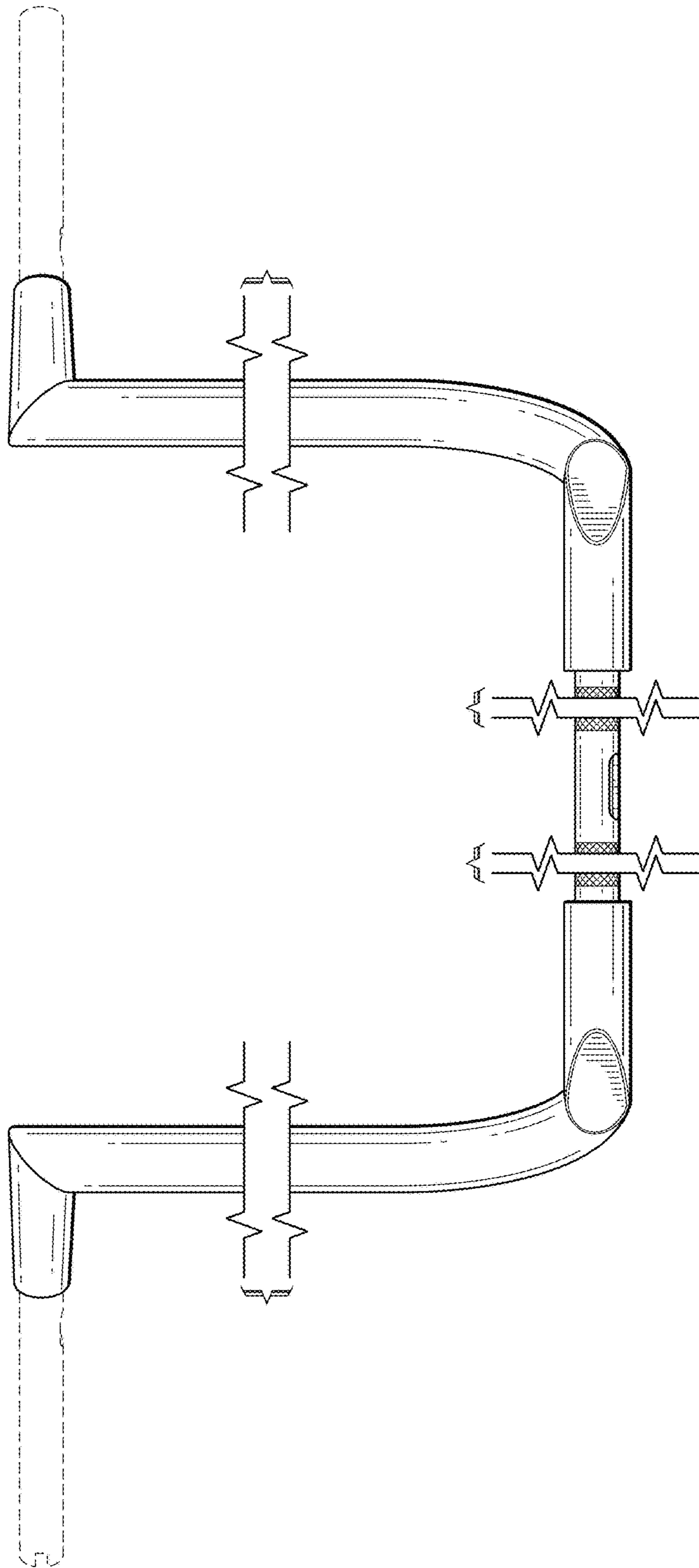

FIG. 2

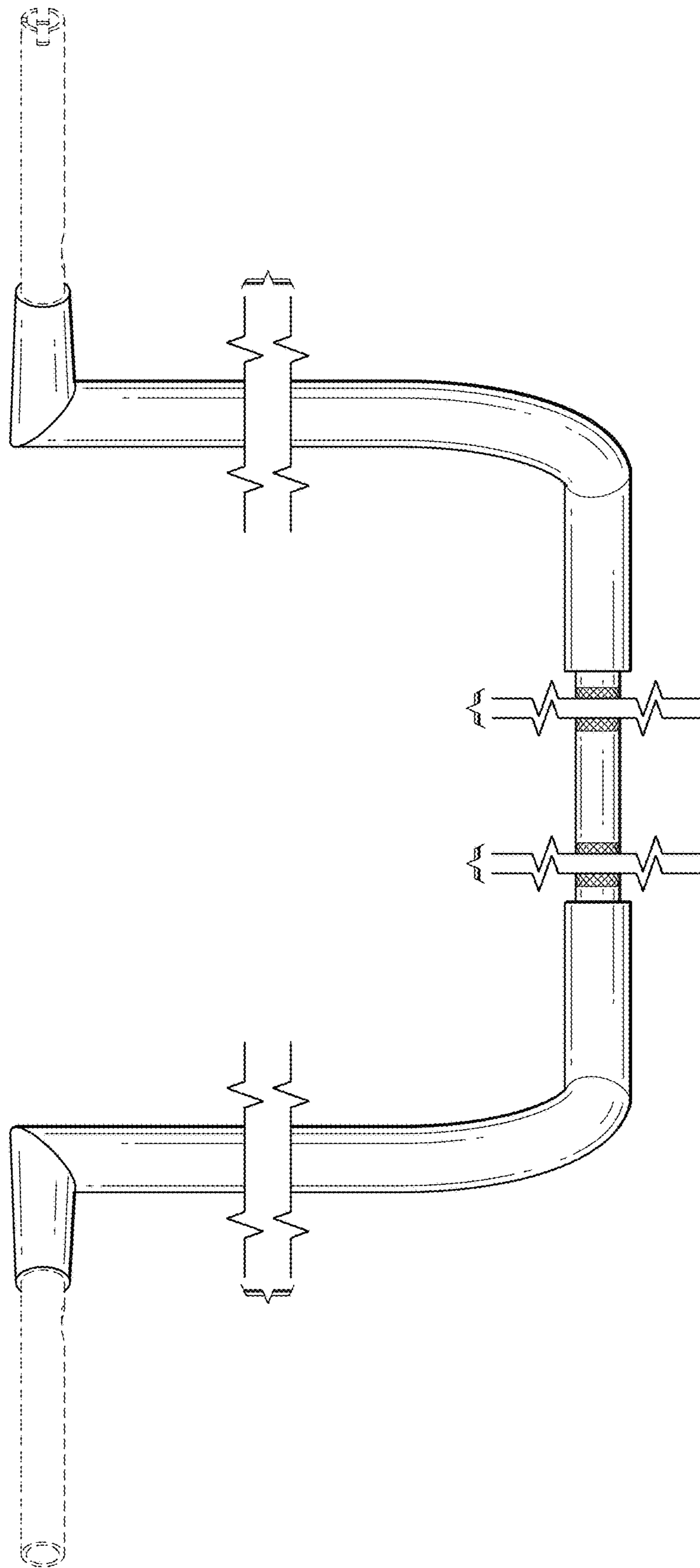

FIG. 3

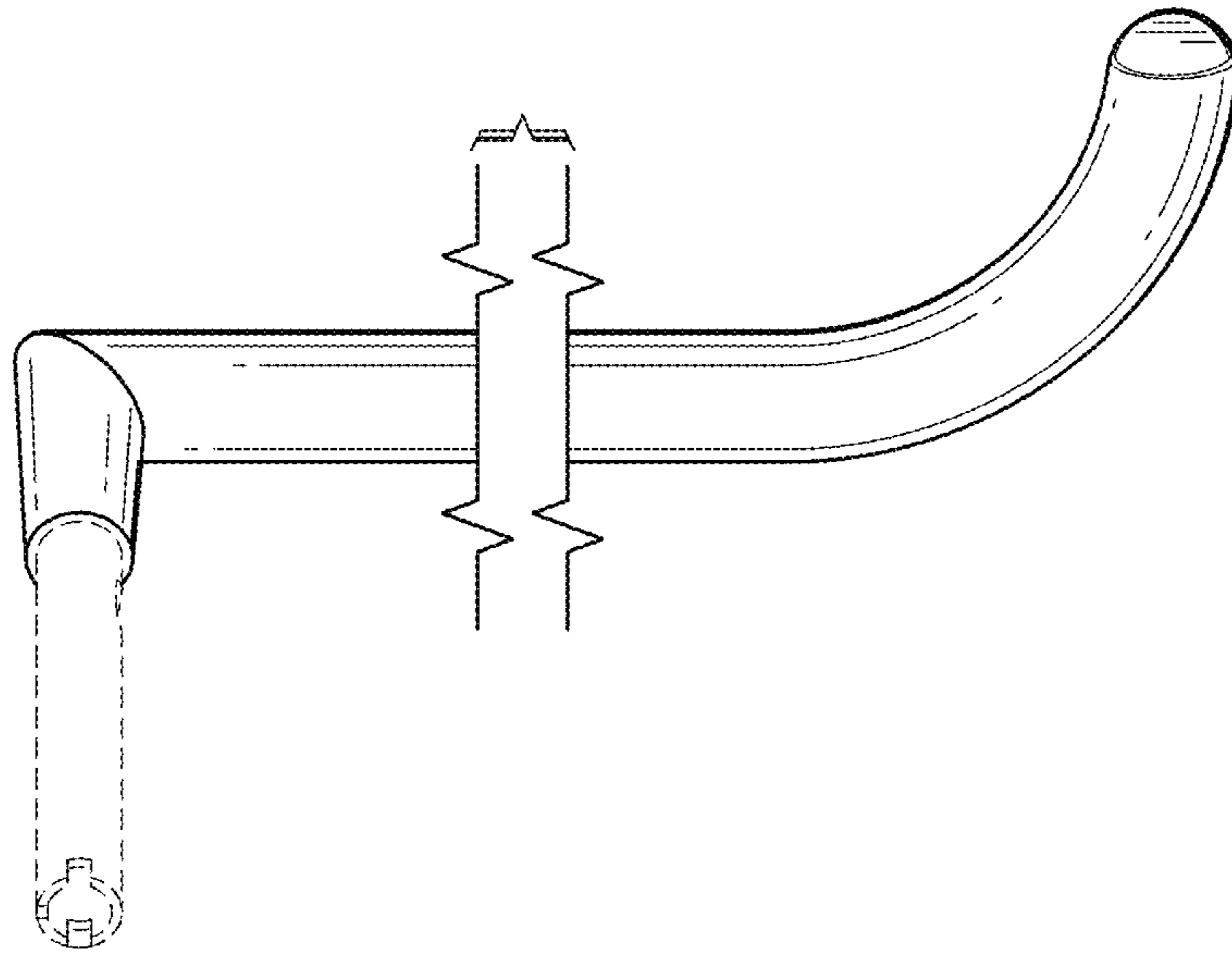

FIG. 5

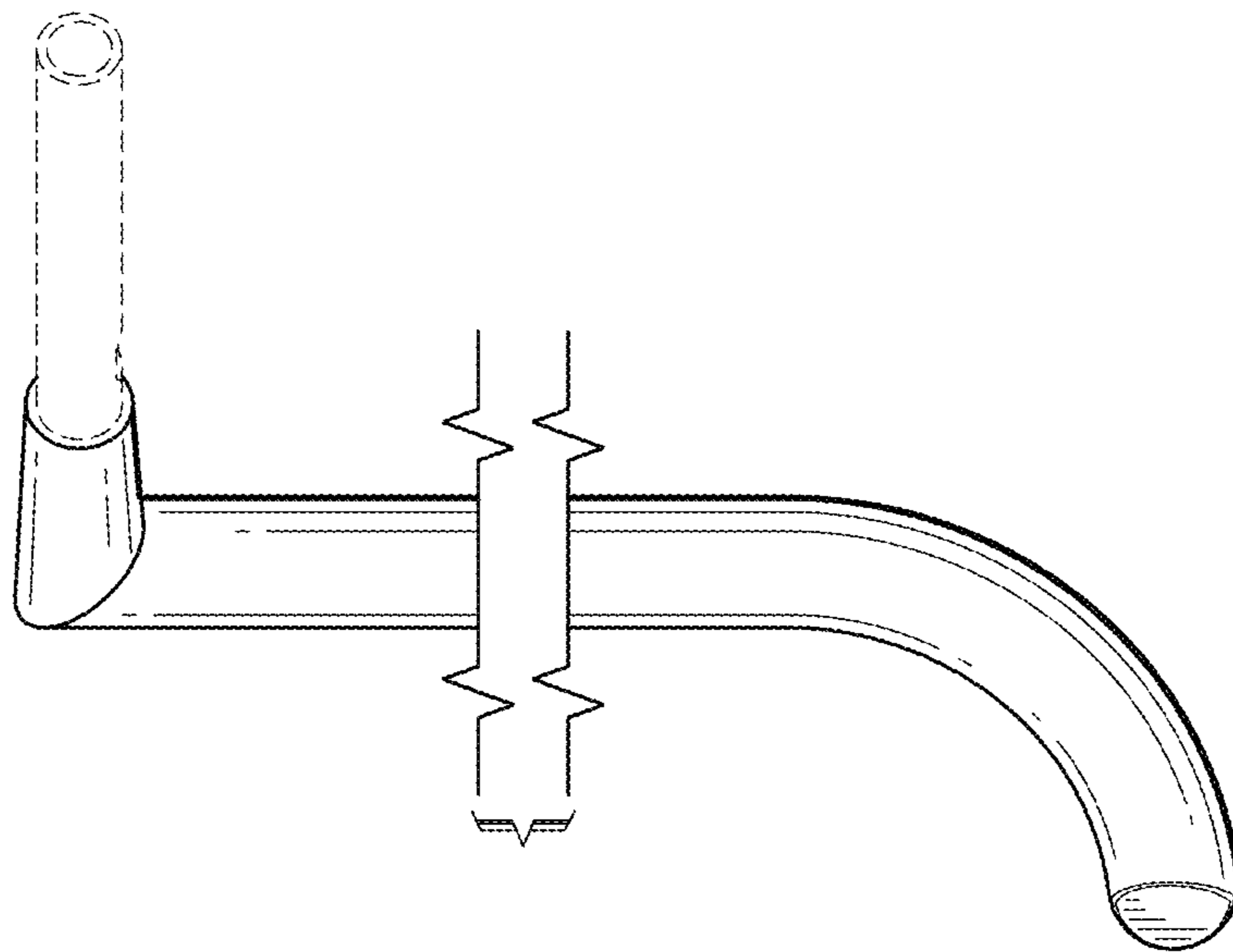

FIG. 4

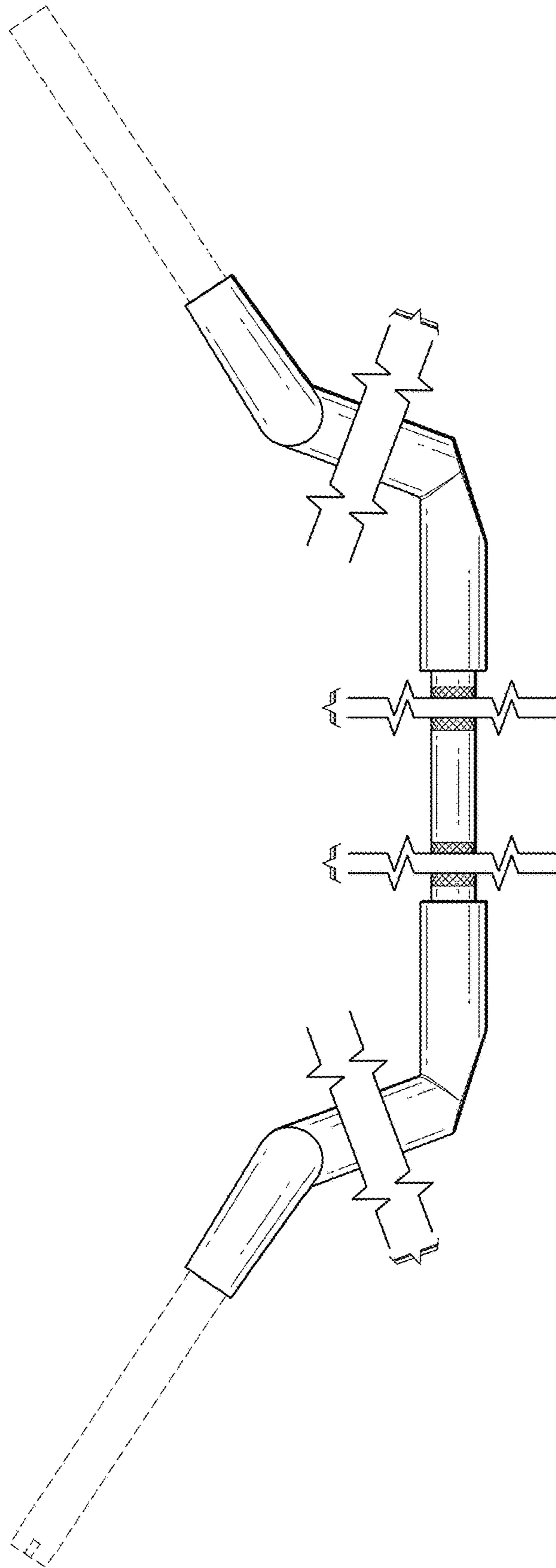

FIG. 6

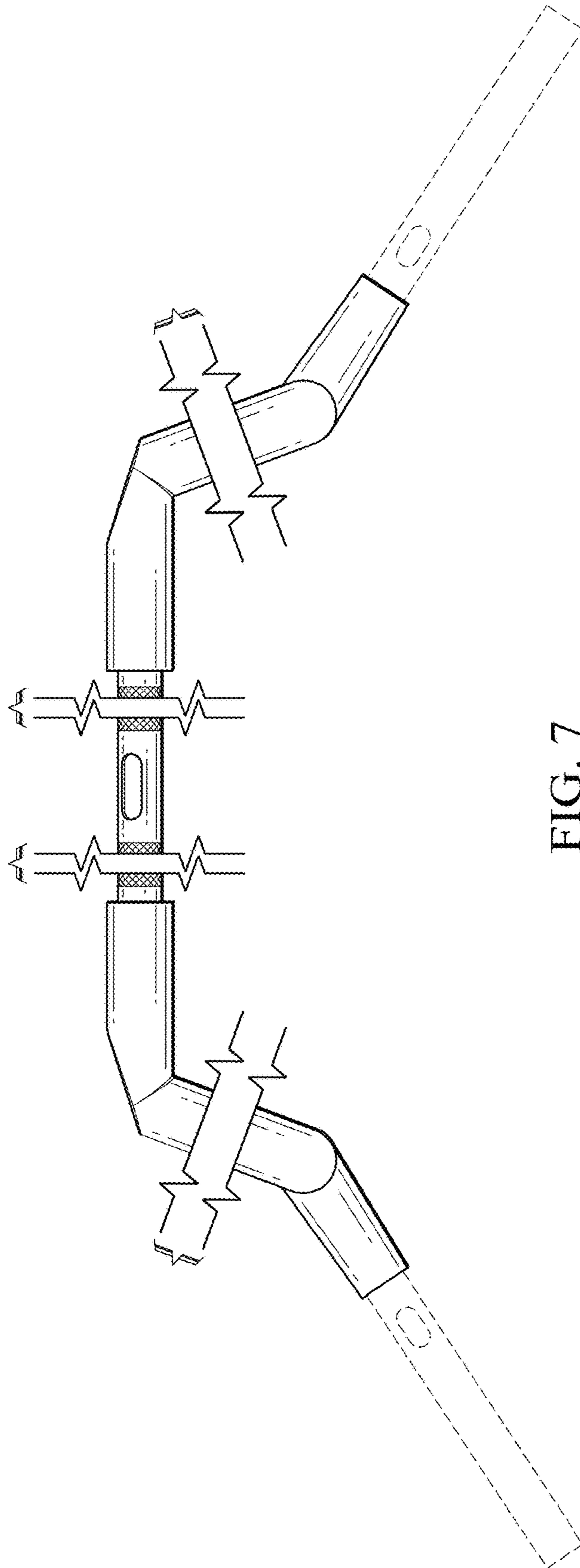

FIG. 7