



US00D831820S

(12) **United States Design Patent** (10) **Patent No.:** **US D831,820 S**  
**Petersen** (45) **Date of Patent:** **\*\* Oct. 23, 2018**

(54) **SYRINGE PUMP HOUSING**  
(71) Applicant: **CSL Behring Recombinant Facility AG, Bern (CH)**  
(72) Inventor: **Carsten Petersen, Hoejbjerg (DK)**  
(73) Assignees: **CSL BEHRING RECOMBINANT FACILITY AG, Bern (CH); MEDICOM INNOVATION PARTNER a/s, Struer (DK)**  
(\*\*) Term: **15 Years**  
(21) Appl. No.: **29/562,963**  
(22) Filed: **Apr. 29, 2016**  
(51) **LOC (11) Cl.** ..... **24-02**  
(52) **U.S. Cl.**  
USPC ..... **D24/111**  
(58) **Field of Classification Search**  
USPC ..... D24/107, 108, 111, 169, 185, 188  
CPC ..... A61M 5/142; A61M 2005/14208; A61M 5/14212; A61M 5/14228; A61M 5/14232; A61M 5/145; A61M 5/1456; A61M 5/14566; A61M 5/1458; A61M 5/1452; A61M 2205/505; A61M 5/14244; A61M 5/1723; A61M 2205/52; G06F 19/3468  
See application file for complete search history.

(56) **References Cited**  
U.S. PATENT DOCUMENTS  
D265,243 S \* 6/1982 Manno ..... D24/111  
4,493,704 A \* 1/1985 Beard ..... A61M 5/1452  
604/154  
4,529,401 A \* 7/1985 Leslie ..... A61M 5/1456  
128/DIG. 1  
4,648,872 A \* 3/1987 Kamen ..... A61M 5/1456  
128/DIG. 12  
4,978,335 A \* 12/1990 Arthur, III ..... A61M 5/1456  
128/DIG. 1

D325,255 S \* 4/1992 Busche ..... D24/108  
D325,781 S \* 4/1992 Moller-Jensen ..... D24/169  
D326,152 S \* 5/1992 Rutter ..... D24/111  
D326,153 S \* 5/1992 Eastman ..... D24/111  
D326,320 S \* 5/1992 Rutter ..... D24/111  
D351,469 S \* 10/1994 Okamoto ..... D24/169  
5,505,709 A \* 4/1996 Funderburk ..... A61M 5/1456  
604/151  
5,637,095 A \* 6/1997 Nason ..... A61M 5/14244  
604/135  
5,954,697 A \* 9/1999 Srisathapat ..... A61M 5/1456  
604/154  
6,302,855 B1 \* 10/2001 Lav ..... A61B 5/14532  
600/584  
D461,241 S \* 8/2002 Moberg ..... D24/111  
D461,891 S \* 8/2002 Moberg ..... D24/111  
D506,007 S \* 6/2005 Best ..... D24/169  
D669,165 S \* 10/2012 Estes ..... D24/111

(Continued)

*Primary Examiner* — Garth Rademaker  
*Assistant Examiner* — Lilyana Bekic  
(74) *Attorney, Agent, or Firm* — Finnegan, Henderson, Farabow, Garrett & Dunner LLP

(57) **CLAIM**

The ornamental design for a syringe pump housing, as shown and described.

**DESCRIPTION**

FIG. 1 is a front bottom right perspective view of a syringe pump housing showing my new design; FIG. 2 is a front elevation view thereof; FIG. 3 is a rear elevation view thereof; FIG. 4 is a top plan view thereof; FIG. 5 is a bottom plan view thereof; FIG. 6 is a left side view thereof; and, FIG. 7 is a right side view thereof. The broken lines shown in the drawings illustrate portions of the syringe pump housing that form no part of the claimed design.

**1 Claim, 5 Drawing Sheets**

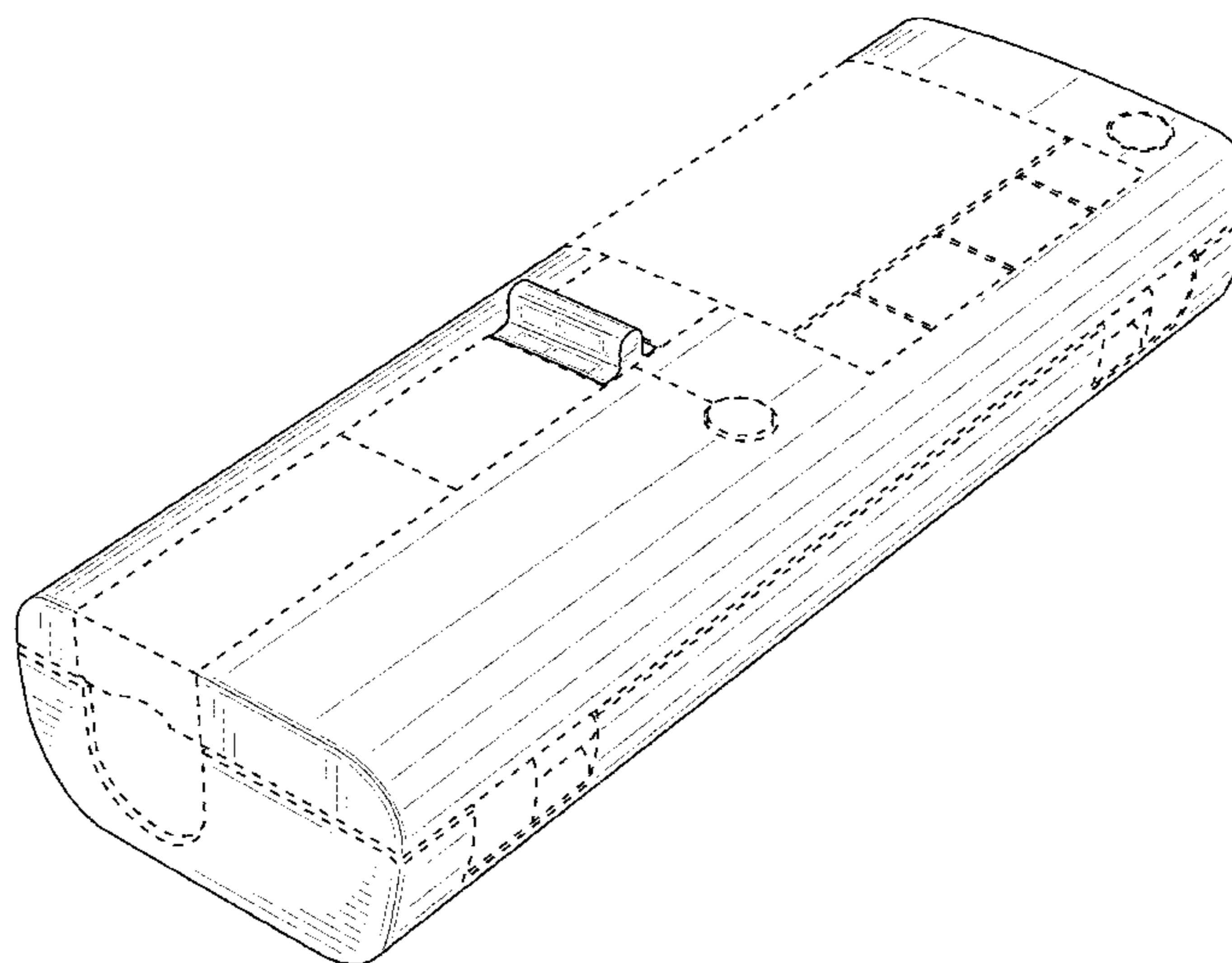

(56)

**References Cited**

U.S. PATENT DOCUMENTS

D669,167	S *	10/2012	Estes .....	D24/111
8,454,562	B1 *	6/2013	Sims .....	A61M 5/14244
				604/151
D689,523	S *	9/2013	Galbraith .....	D15/7
D691,258	S *	10/2013	Estes .....	D24/111
D691,259	S *	10/2013	Estes .....	D24/111
9,427,523	B2 *	8/2016	Qi	
D791,306	S *	7/2017	Clemente et al. ....	D24/111
9,833,569	B2 *	12/2017	Gray .....	A61M 5/14244
D809,134	S *	1/2018	Crothall .....	D24/111
9,861,740	B2 *	1/2018	Adams .....	A61M 5/1452
9,878,095	B2 *	1/2018	Alderete, Jr. ....	A61M 5/16831
9,956,339	B2 *	5/2018	Smith .....	A61M 5/14244
9,962,482	B2 *	5/2018	Patel .....	A61M 5/1413
2001/0034502	A1 *	10/2001	Moberg .....	A61M 5/1456
				604/154
2008/0306449	A1 *	12/2008	Kristensen .....	A61M 5/20
				604/192
2011/0040247	A1 *	2/2011	Mandro .....	A61M 5/142
				604/66
2018/0117253	A1 *	5/2018	Salahshoor Kordestani .....	
				A61M 5/30

\* cited by examiner

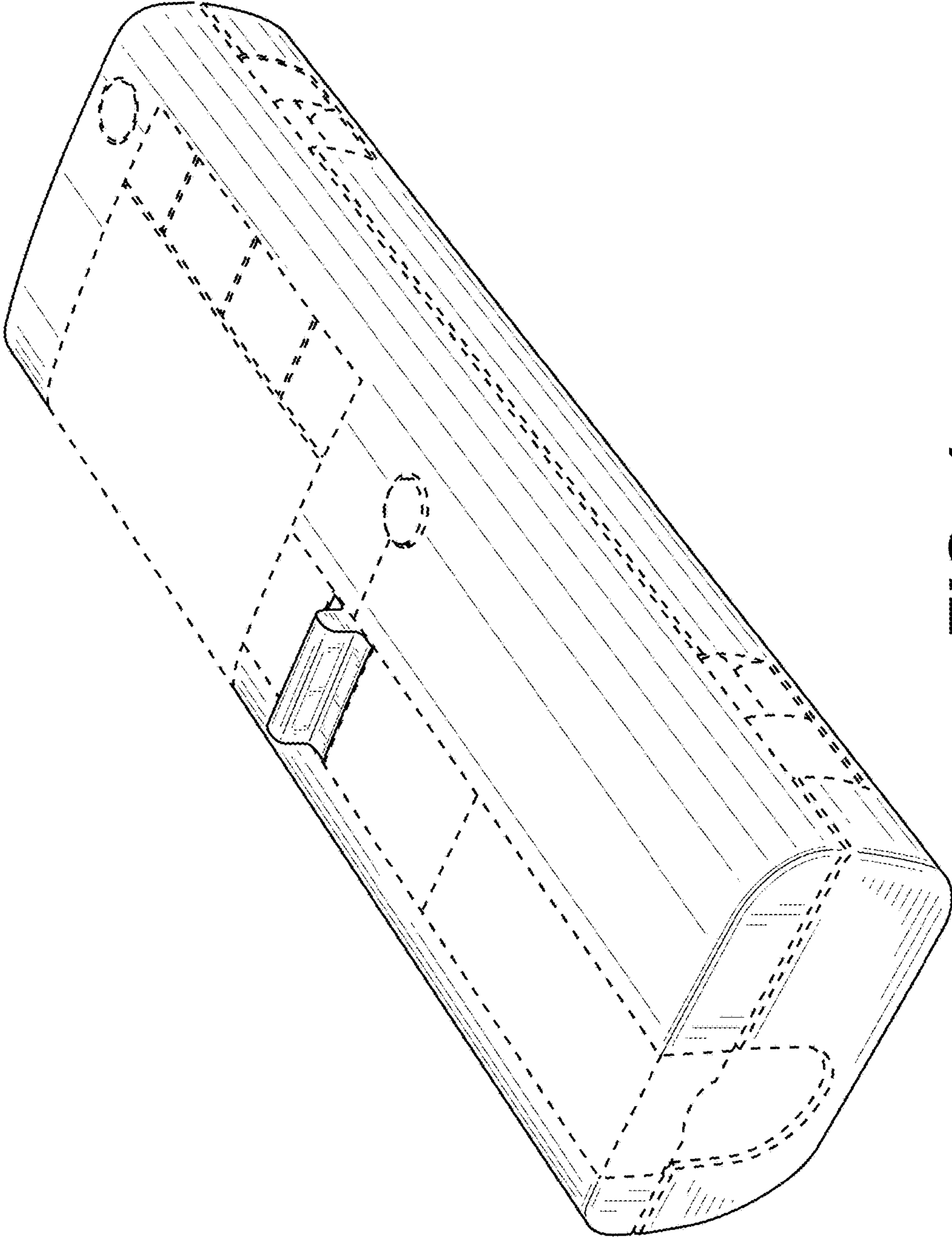

**FIG. 1**

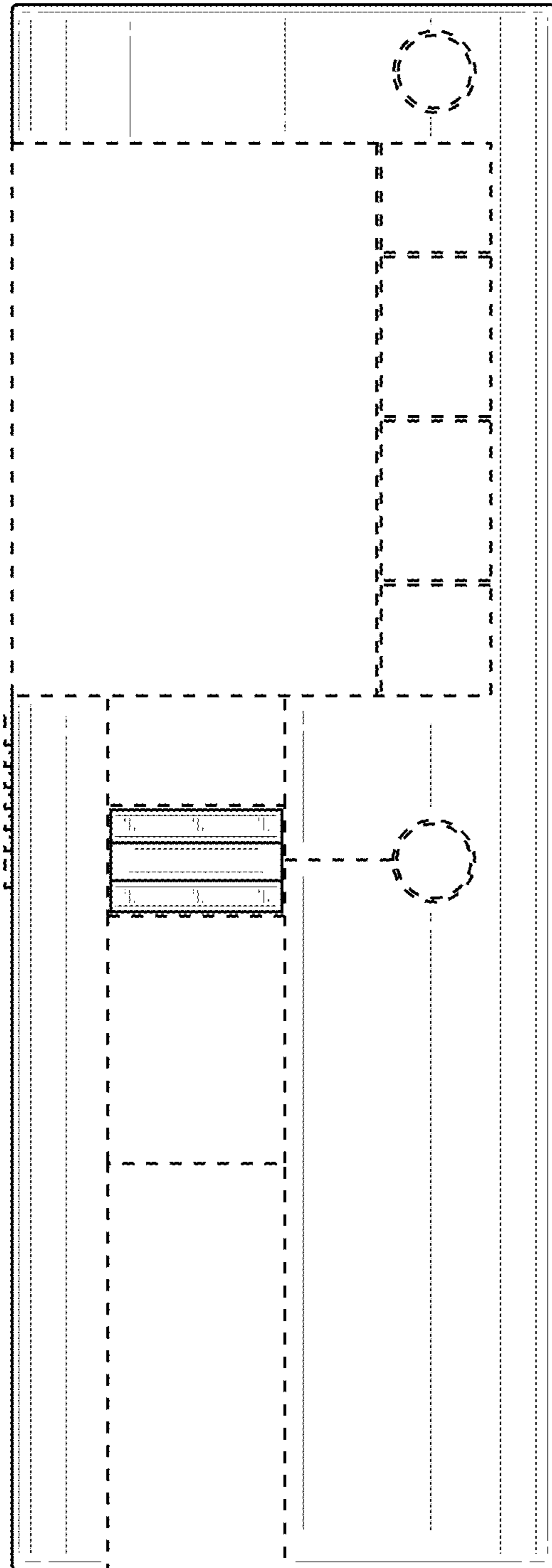

**FIG. 2**

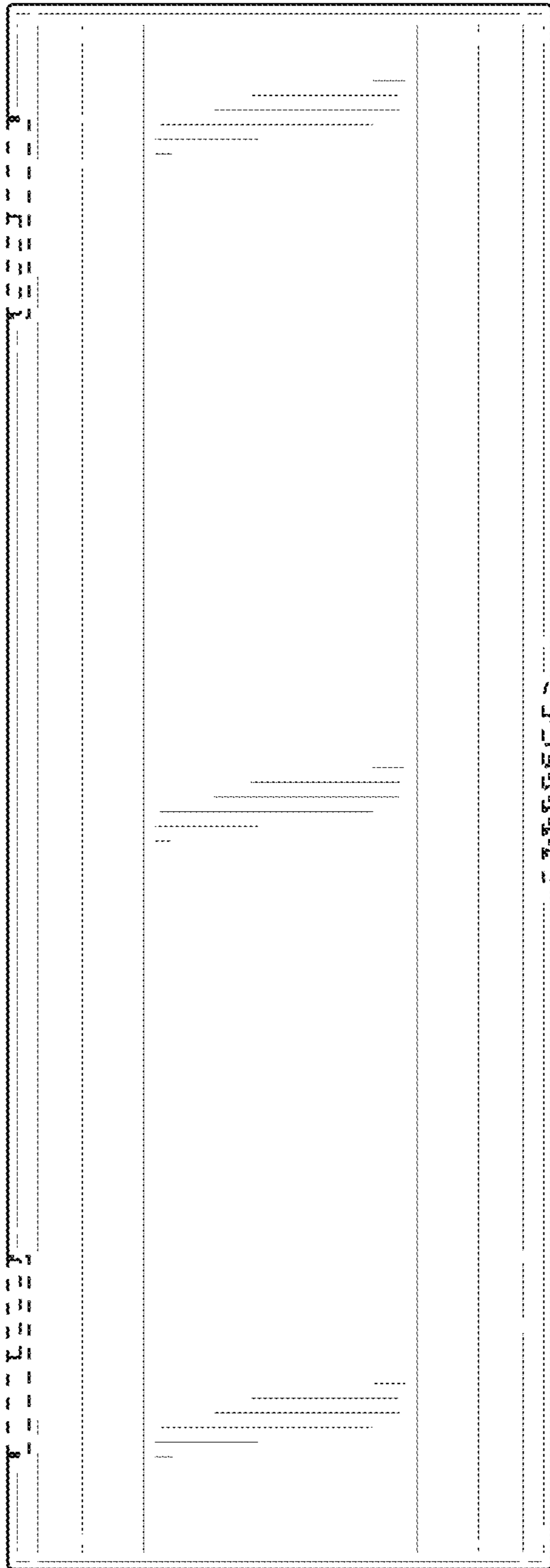

**FIG. 3**

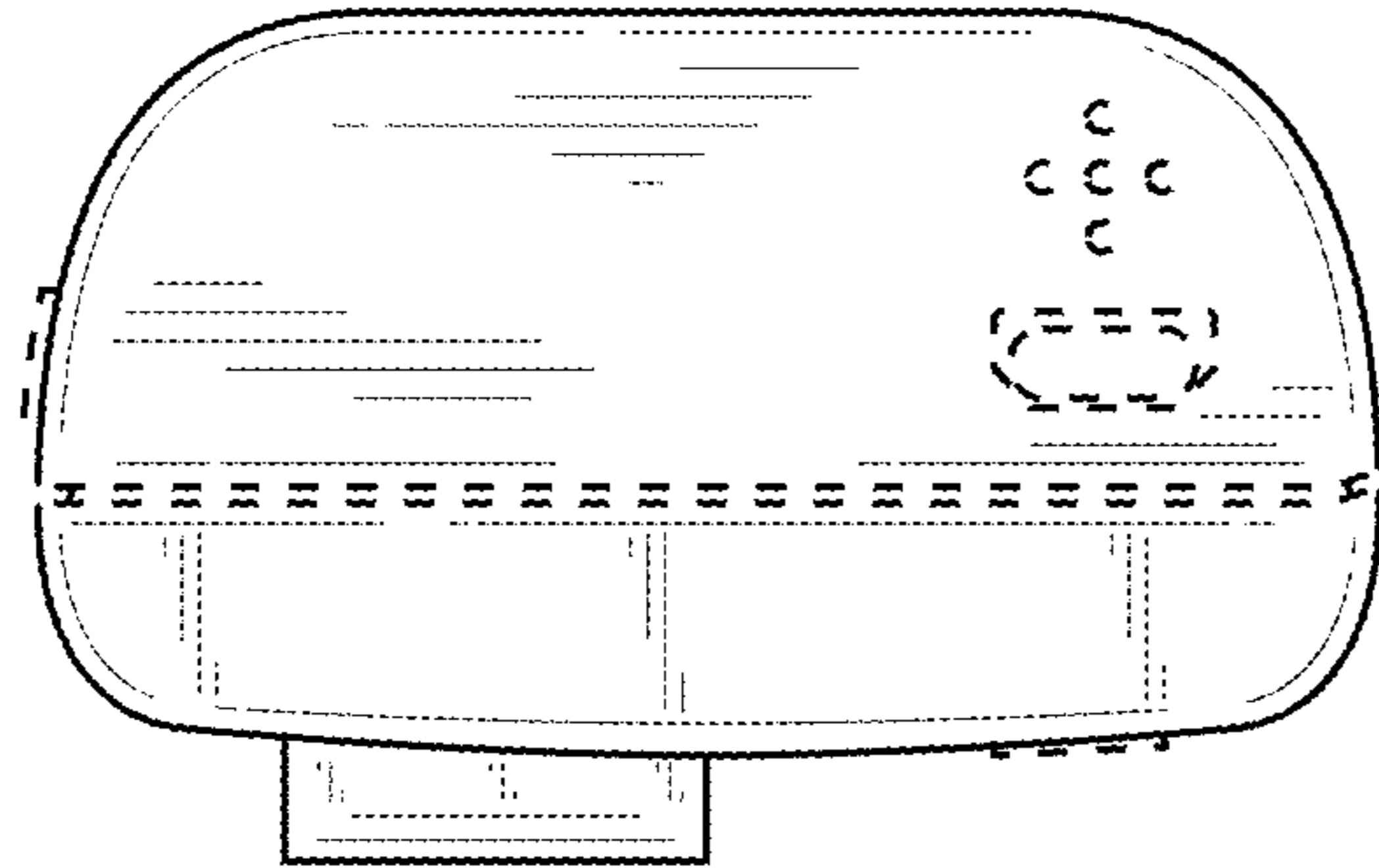

**FIG. 4**

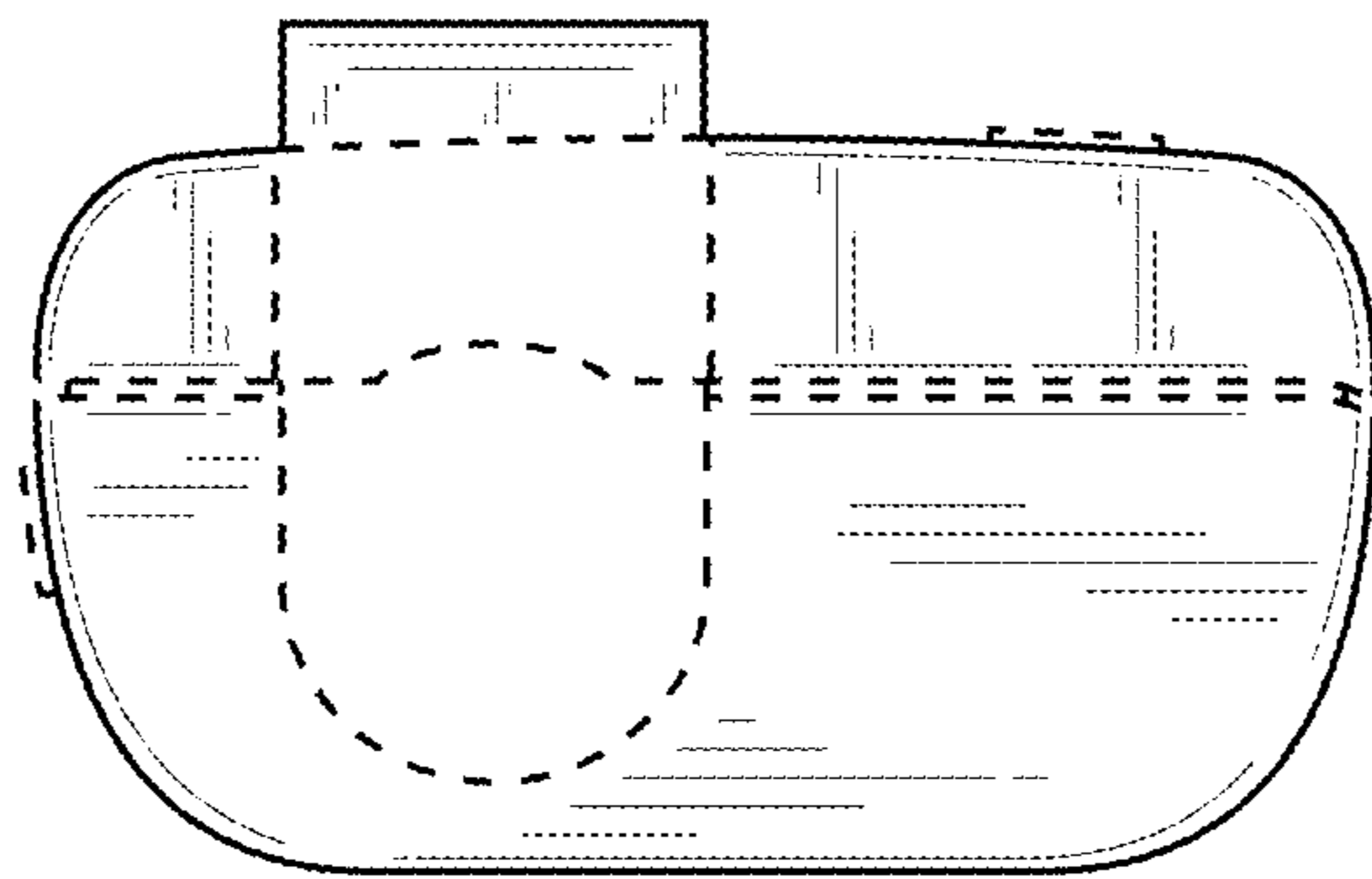

**FIG. 5**

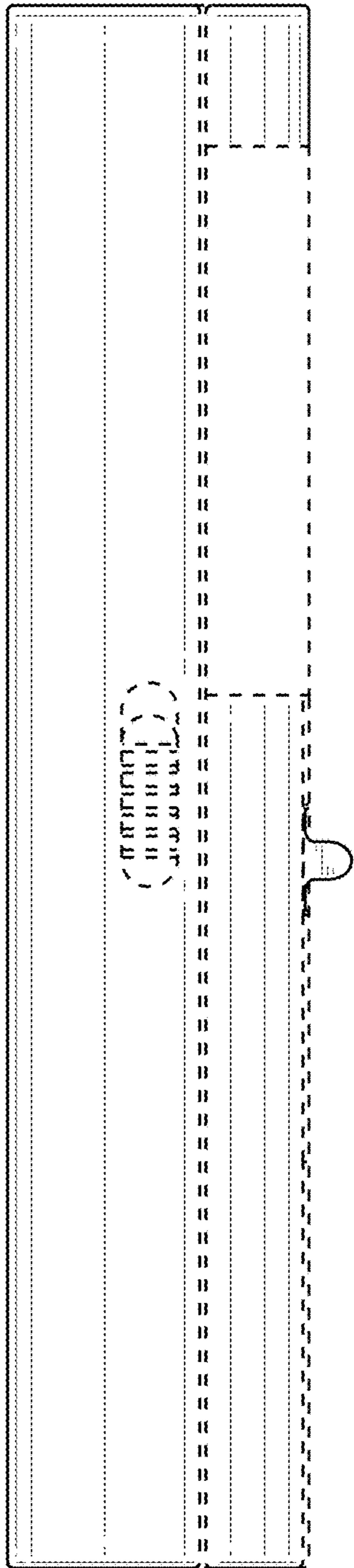

**FIG. 6**

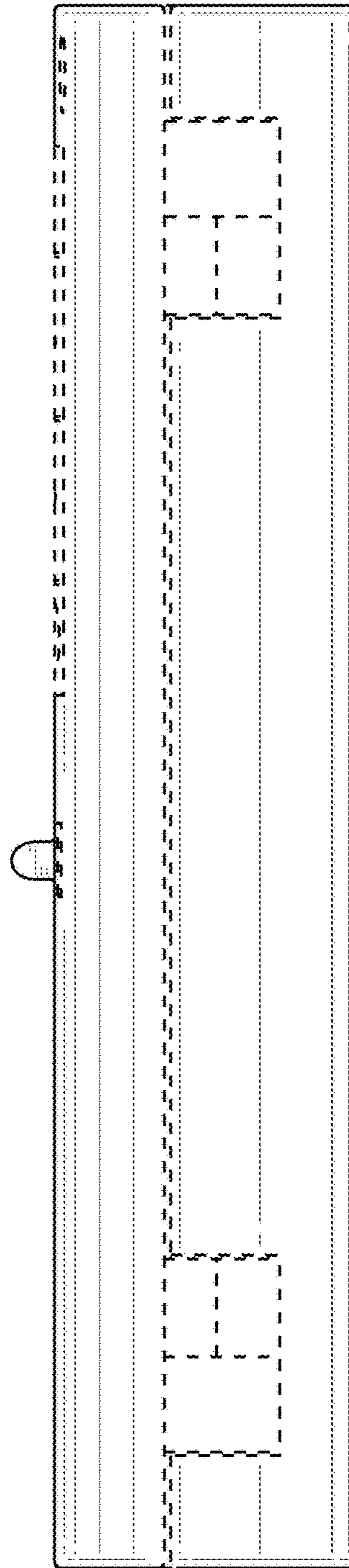

**FIG. 7**