



US00D831143S

(12) **United States Design Patent** (10) **Patent No.:** **US D831,143 S**
Sato (45) **Date of Patent:** **** Oct. 16, 2018**

(54) **ONE-PERSON RIDING MOBILE APPARATUS**

(71) Applicant: **Koichi Sato**, Fukuoka (JP)

(72) Inventor: **Koichi Sato**, Fukuoka (JP)

(73) Assignee: **Koichi Sato**, Fukuoka (JP)

(**) Term: **15 Years**

(21) Appl. No.: **29/600,252**

(22) Filed: **Apr. 11, 2017**

(30) **Foreign Application Priority Data**

Oct. 11, 2016 (JP) 2016-022085

(51) **LOC (11) Cl.** **21-02**

(52) **U.S. Cl.**
USPC **D21/765; D21/419**

(58) **Field of Classification Search**
USPC D21/419, 421, 423, 426, 662, 760, 765,
D21/766, 769, 771, 776, 803; D12/1;
D34/23, 27

CPC A63C 17/01; A63C 17/011; A63C 17/012;
A63C 17/014; A63C 17/015; A63C
17/02; A63C 17/26; A63C 5/003; B60Q
1/326; B62K 3/001

See application file for complete search history.

(56) **References Cited**

U.S. PATENT DOCUMENTS

D255,258 S * 6/1980 Lukes D21/765
D352,586 S * 11/1994 Baucom D34/23
D484,664 S * 12/2003 Arceta D34/27
D650,545 S * 12/2011 Malone, Jr. D34/23
D711,614 S * 8/2014 Shitrit D34/23

9,844,719 B1 * 12/2017 Huang A63C 17/12
D810,218 S * 2/2018 Huang D21/765
2006/0231313 A1 * 10/2006 Ishii A63C 17/12
180/218
2008/0029991 A1 * 2/2008 Su A63C 17/01
280/243
2015/0008058 A1 * 1/2015 Sato A63C 17/011
180/181
2016/0367884 A1 * 12/2016 Chiu A63C 17/12
2017/0087442 A1 * 3/2017 Yang A63C 17/011
2017/0259163 A1 * 9/2017 Zhou A63C 17/12

* cited by examiner

Primary Examiner — Cynthia M. Chin

(74) *Attorney, Agent, or Firm* — Polsinelli PC

(57) **CLAIM**

The ornamental design for a one-person riding mobile apparatus, as shown and described.

DESCRIPTION

FIG. 1 is a front view of the one-person riding mobile apparatus showing my new design;
FIG. 2 is a back view thereof;
FIG. 3 is a top view thereof;
FIG. 4 is a bottom view thereof;
FIG. 5 is a right side view thereof;
FIG. 6 is a left side view thereof;
FIG. 7 is a cross-section view through 7-7 of FIG. 1;
FIG. 8 is a cross-section view through 8-8 of FIG. 4;
FIG. 9 is a top perspective view of FIG. 1;
FIG. 10 is a bottom perspective view of FIG. 2;
FIG. 11 is a front view when a person is riding;
FIG. 12 is a back view when a person is riding; and,
FIG. 13 is a top perspective view when a person is riding.

1 Claim, 7 Drawing Sheets

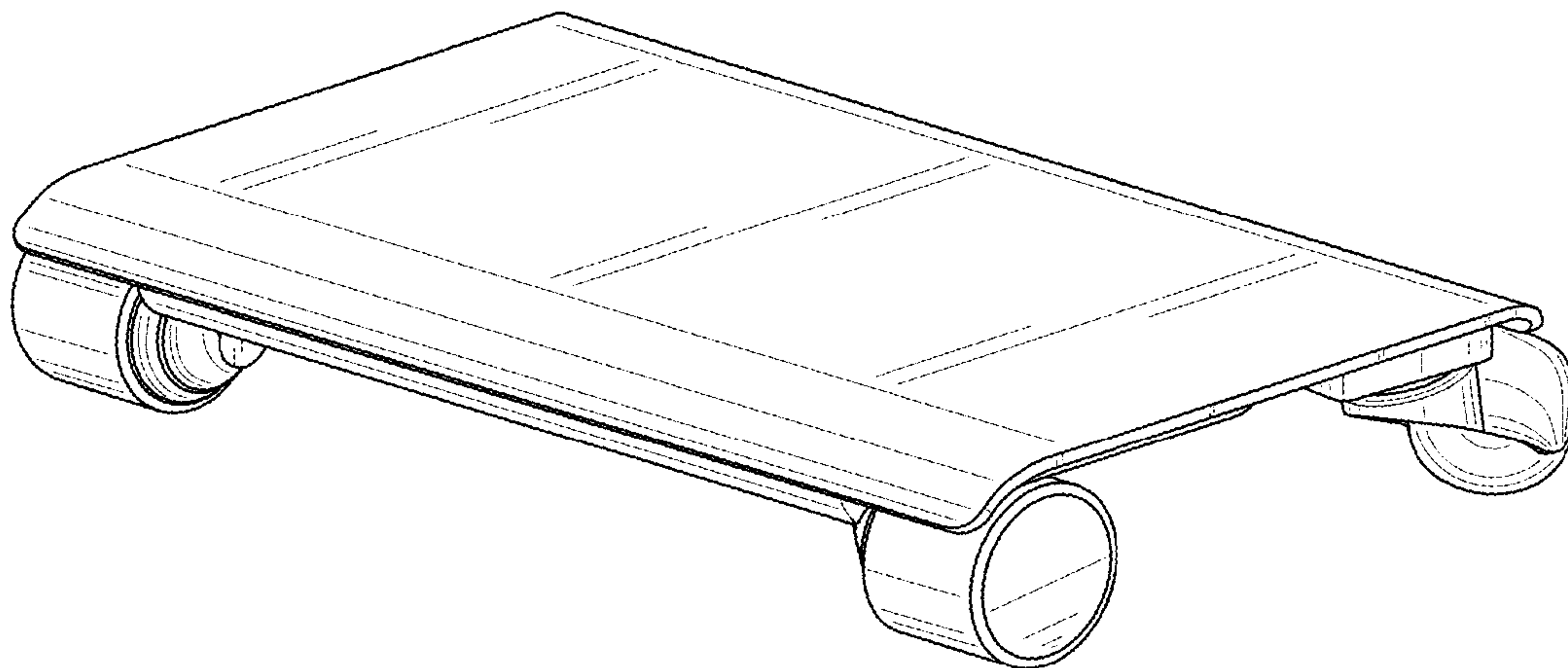

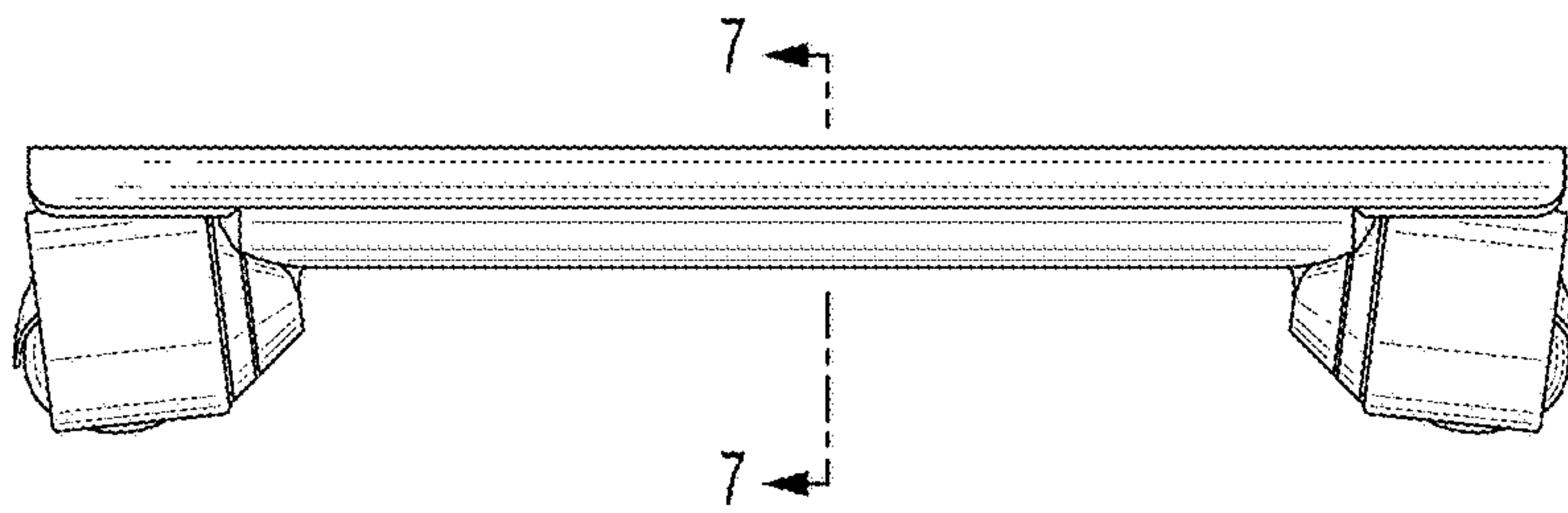

FIG. 1

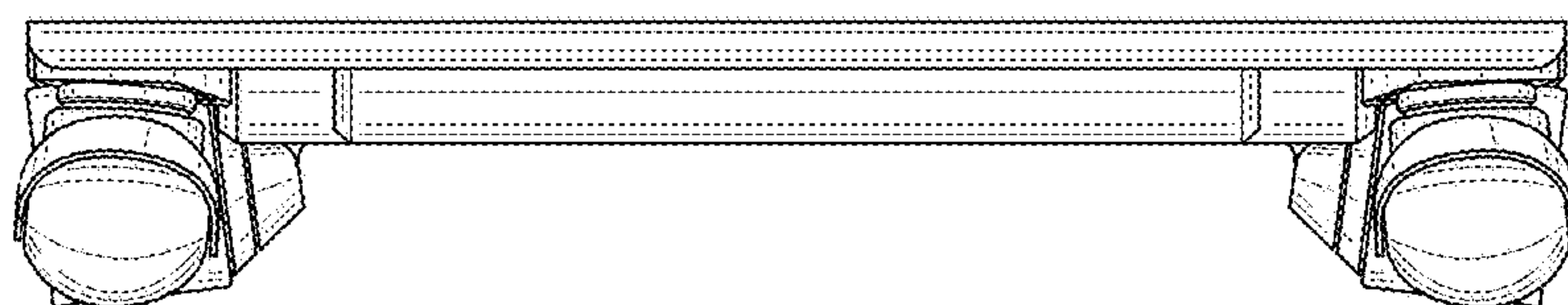

FIG. 2

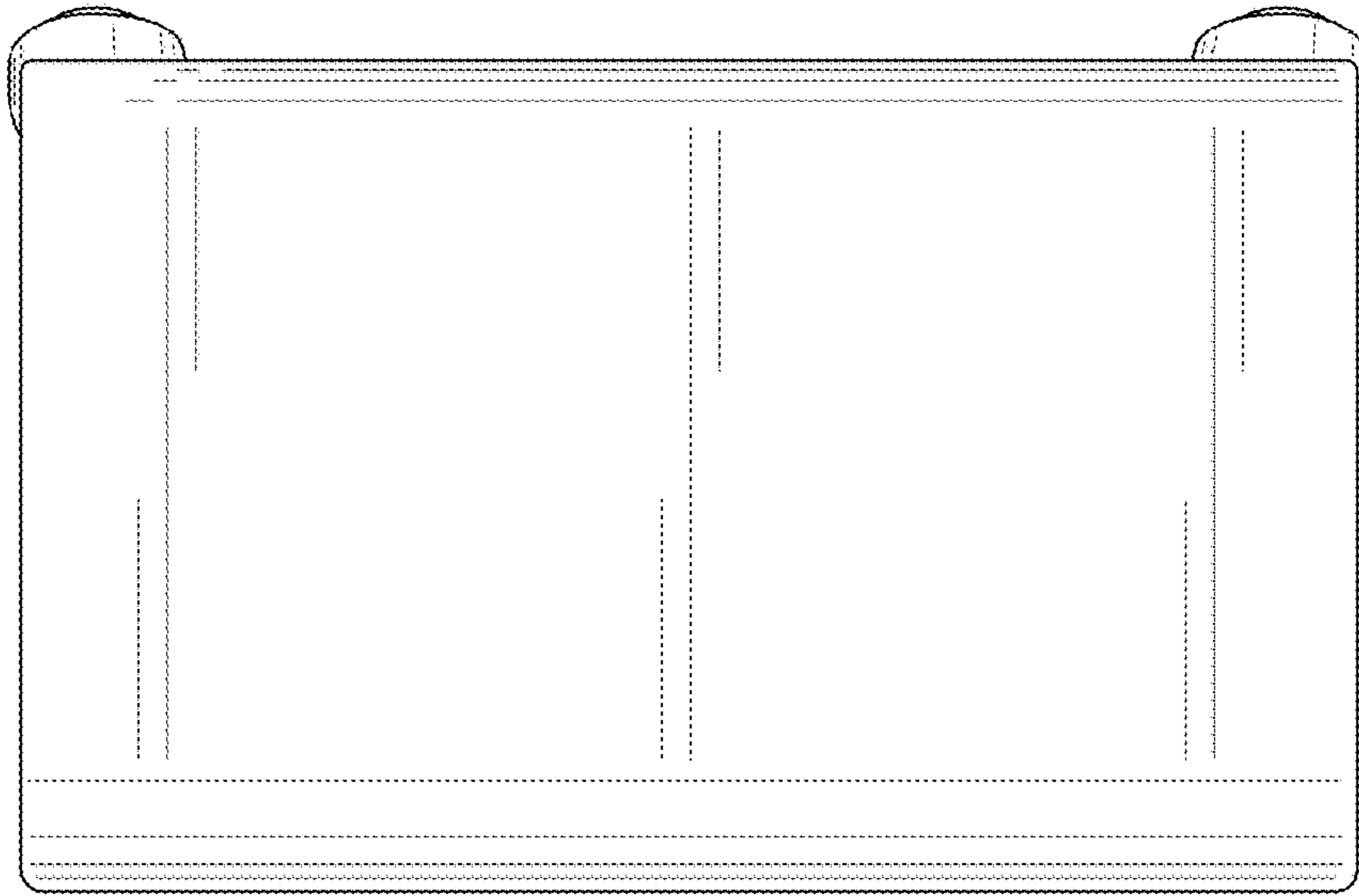

FIG. 3

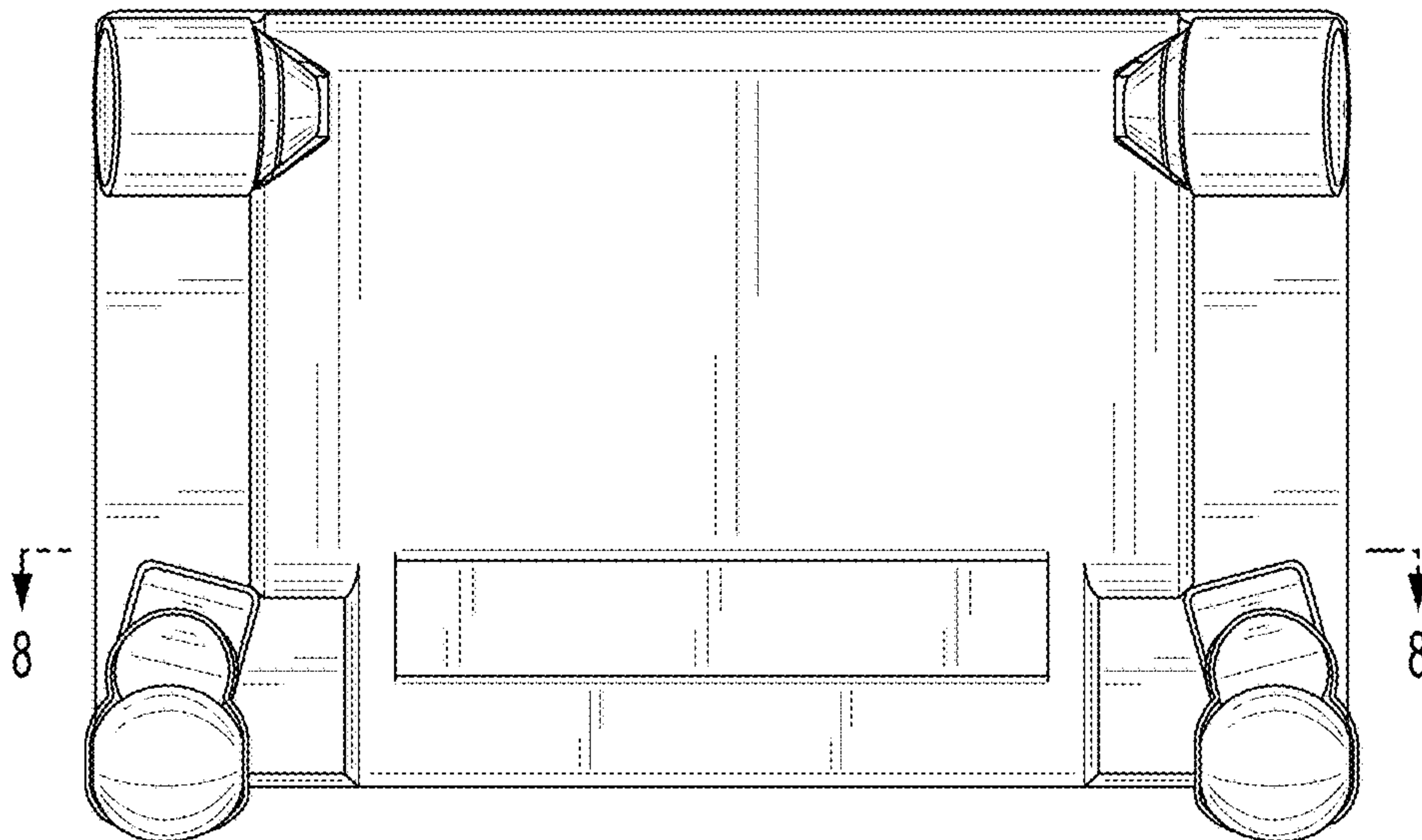

FIG. 4

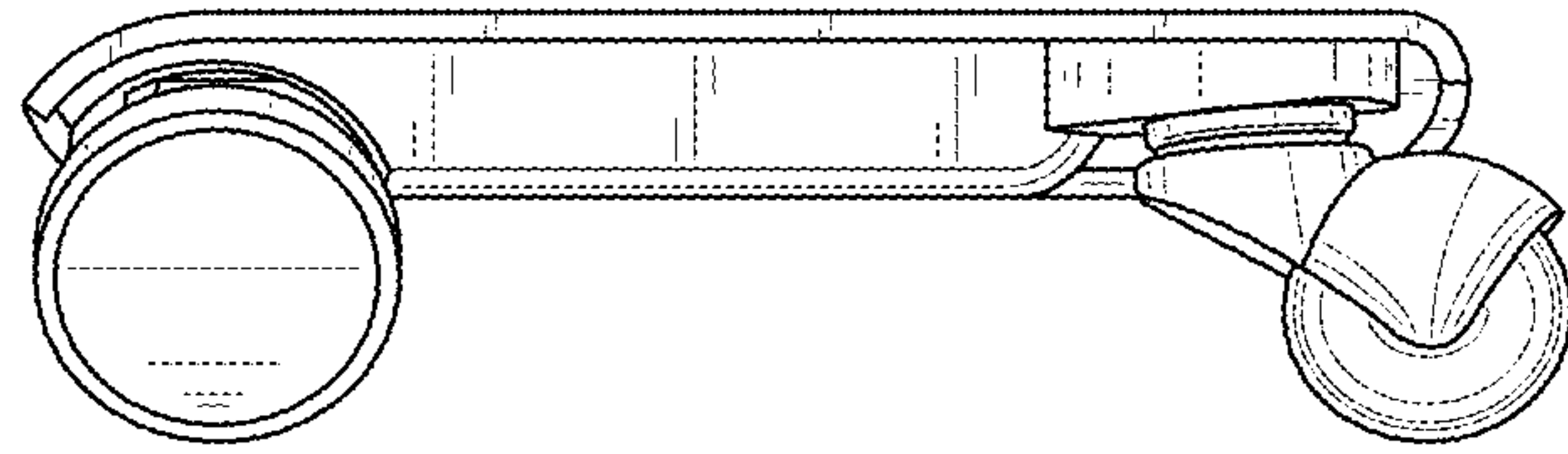

FIG. 5

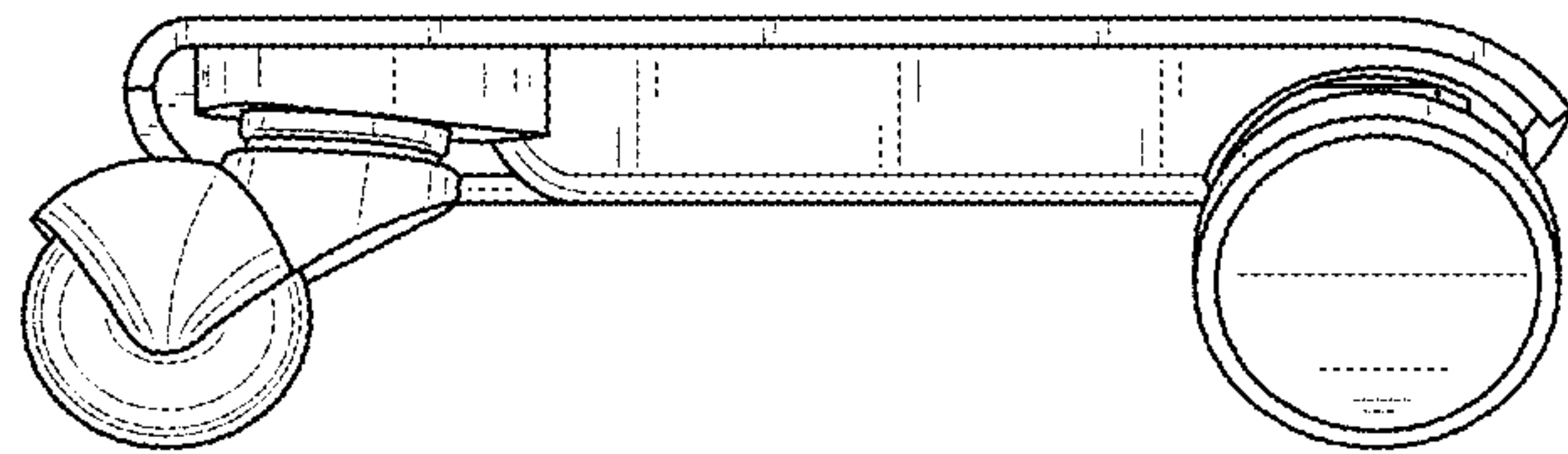

FIG. 6

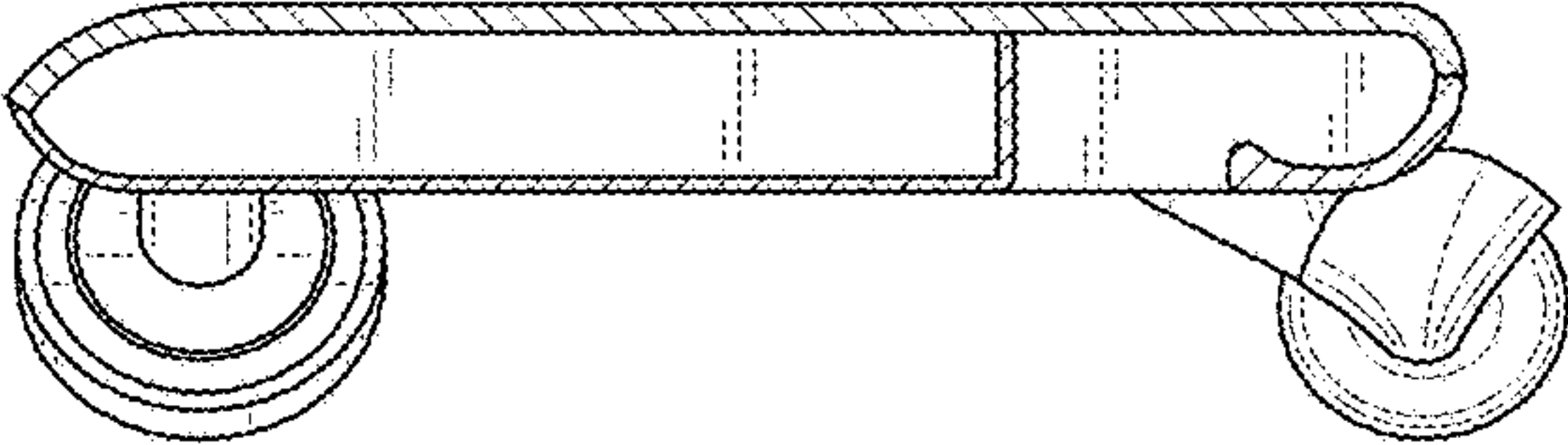

FIG. 7

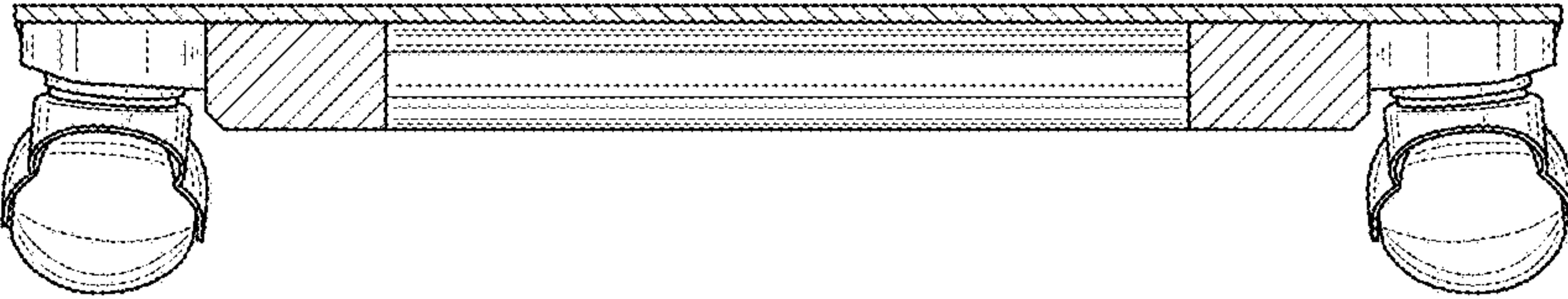

FIG. 8

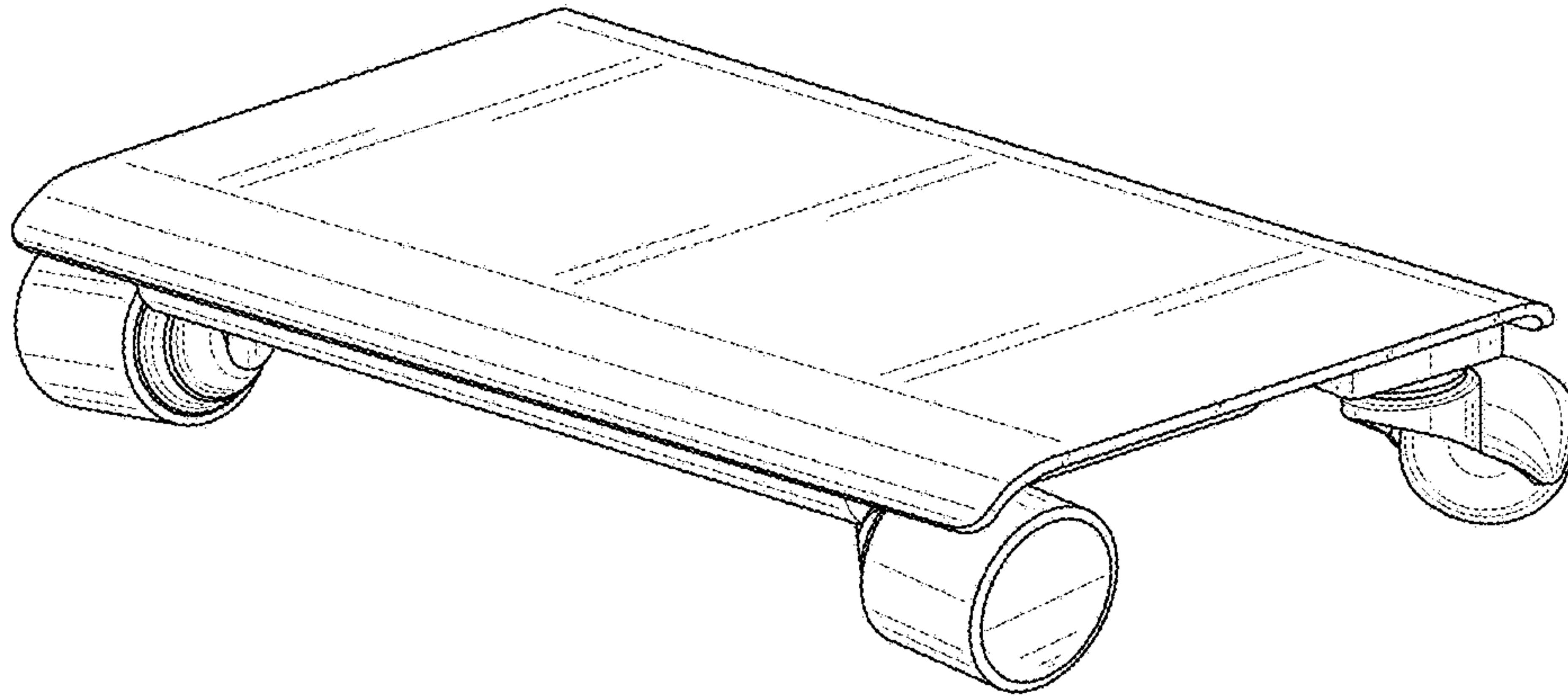

FIG. 9

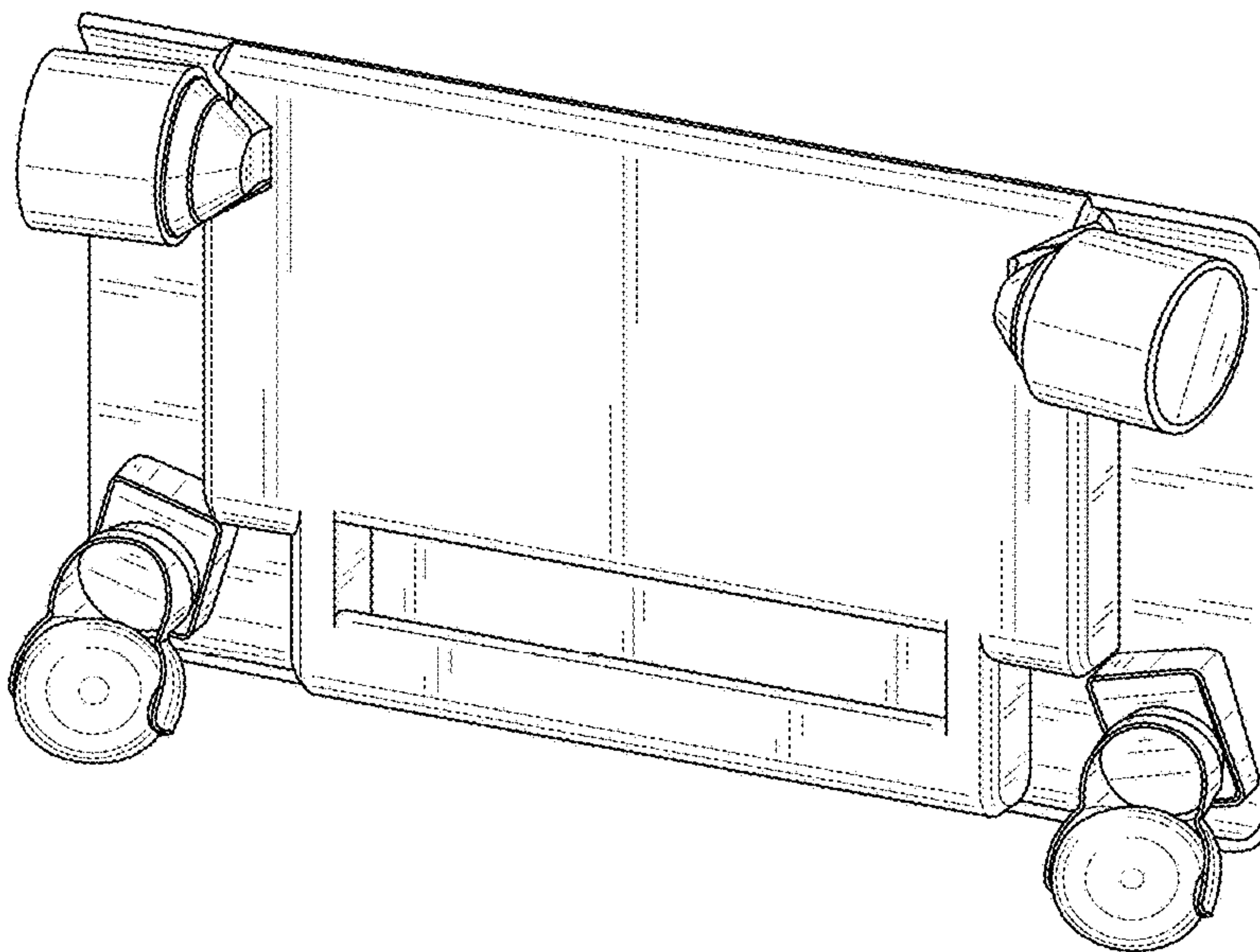

FIG. 10

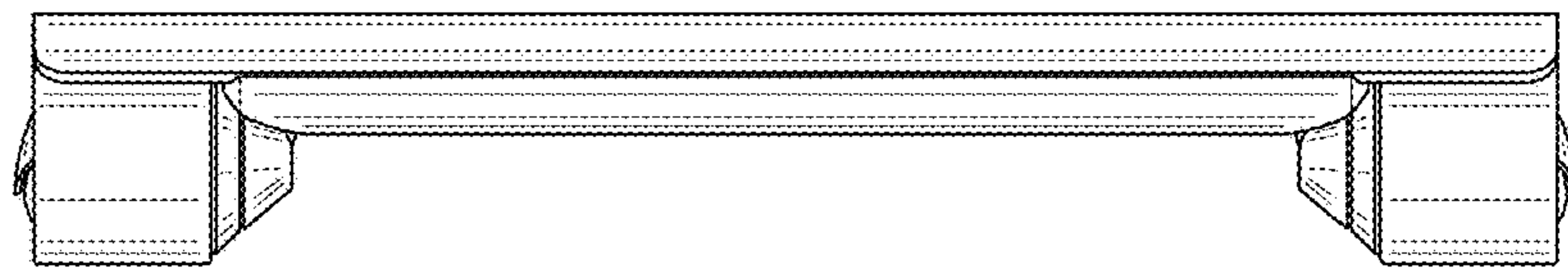

FIG. 11

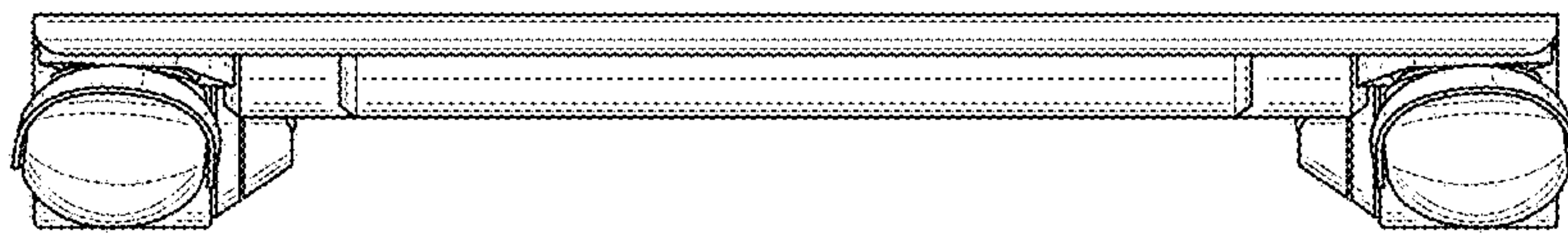

FIG. 12

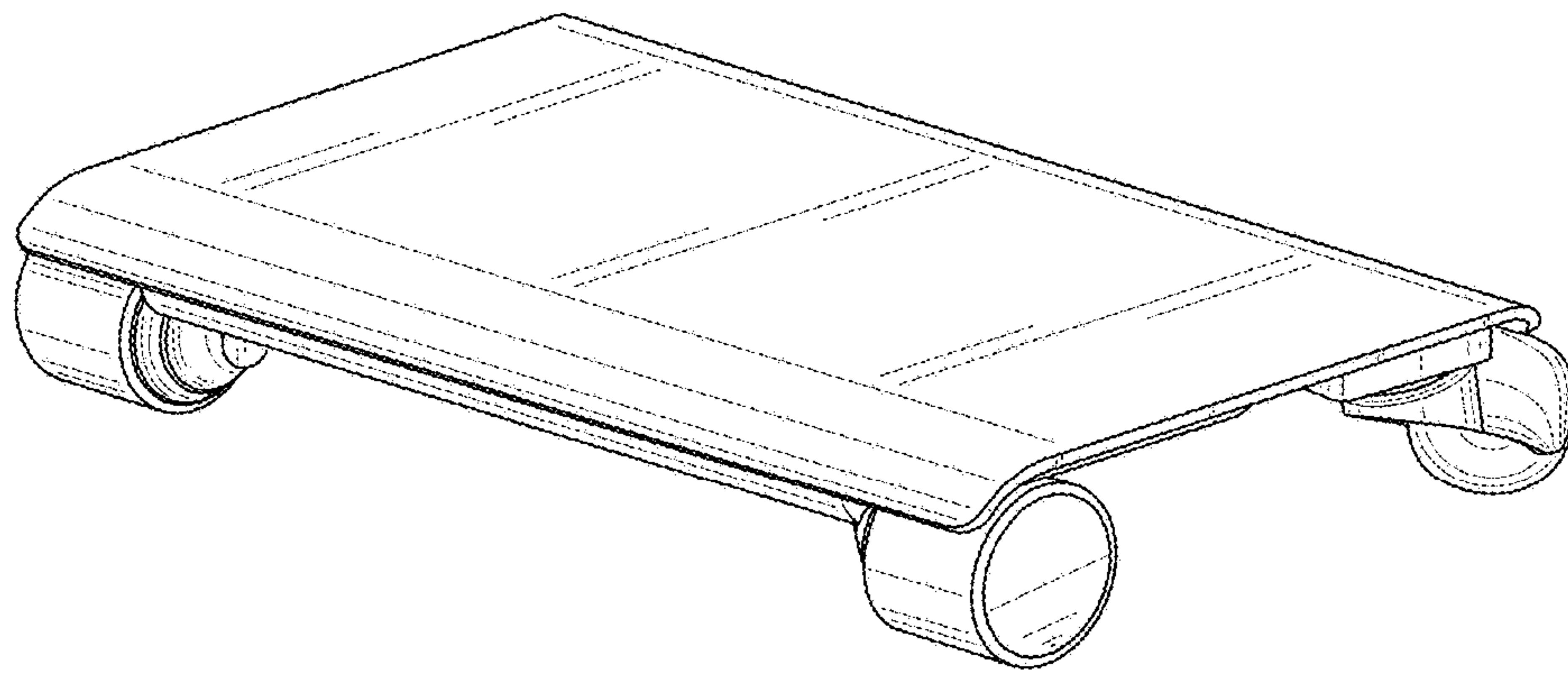

FIG. 13