



US00D830289S

(12) **United States Design Patent**
Mita et al.

(10) **Patent No.:** **US D830,289 S**
(45) **Date of Patent:** **** Oct. 9, 2018**

(54) **AUTOMOBILE TIRE**

(56) **References Cited**

(71) Applicant: **THE YOKOHAMA RUBBER CO., LTD.**, Minato-ku, Tokyo (JP)

U.S. PATENT DOCUMENTS

D609,166 S * 2/2010 Brown D12/583
D796,428 S * 9/2017 Tian D12/583

(72) Inventors: **Masaya Mita**, Hiratsuka (JP); **Makoto Ishii**, Tokyo (JP)

* cited by examiner

Primary Examiner — Robert Middleton Spear

(73) Assignee: **THE YOKOHAMA RUBBER CO., LTD.**, Minato-ku, Tokyo (JP)

(74) *Attorney, Agent, or Firm* — Banner & Witcoff, Ltd.

(**) Term: **15 Years**

(57) **CLAIM**

The ornamental design for an automobile tire, as shown and described.

(21) Appl. No.: **29/590,067**

DESCRIPTION

(22) Filed: **Jan. 6, 2017**

FIG. 1 is a perspective view of an automobile tire showing our new design;

FIG. 2 is a front view thereof;

FIG. 3 is a rear view thereof;

FIG. 4 is a right side view thereof;

FIG. 5 is a left side view thereof;

FIG. 6 is a top view thereof;

FIG. 7 is a bottom view thereof;

FIG. 8 is a partially enlarged view of a portion defined by lines 8-8 shown in FIG. 1;

FIG. 9 is a partially enlarged view of a portion defined by lines 9-9 shown in FIG. 2 and,

FIG. 10 is a cross sectional view of a portion defined by lines 10-10 shown in FIG. 9.

In the drawings, the broken lines depict environmental subject matter only and form no part of the claimed design.

(30) **Foreign Application Priority Data**

Jul. 8, 2016 (JP) 2016-014604

(51) **LOC (11) Cl.** **12-15**

(52) **U.S. Cl.**
USPC **D12/584**

(58) **Field of Classification Search**
USPC D12/570, 582, 583, 584, 585, 596, 597,
D12/598, 602, 603
CPC B60C 11/03; B60C 2011/0344
See application file for complete search history.

1 Claim, 10 Drawing Sheets

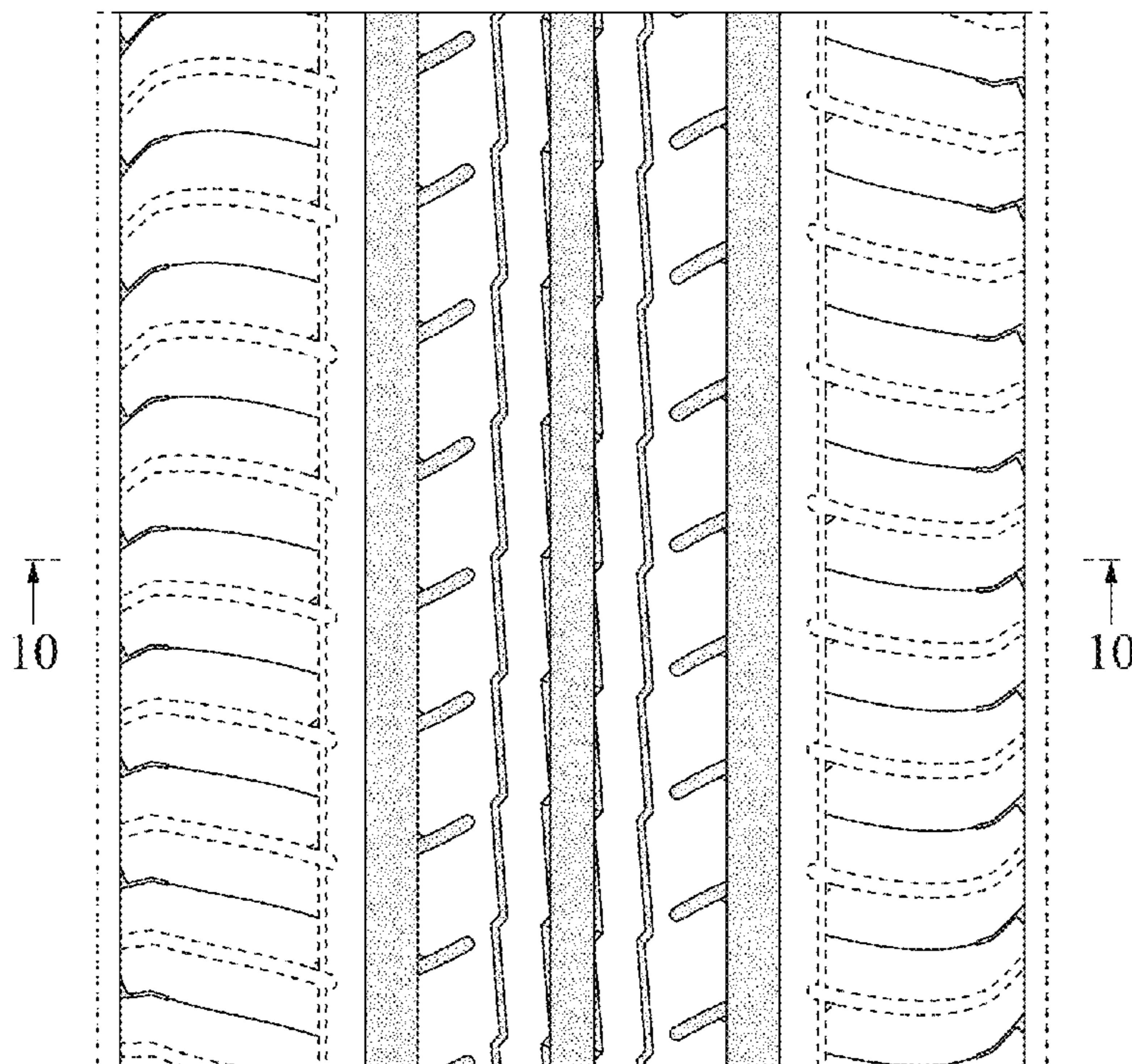

FIG. 1

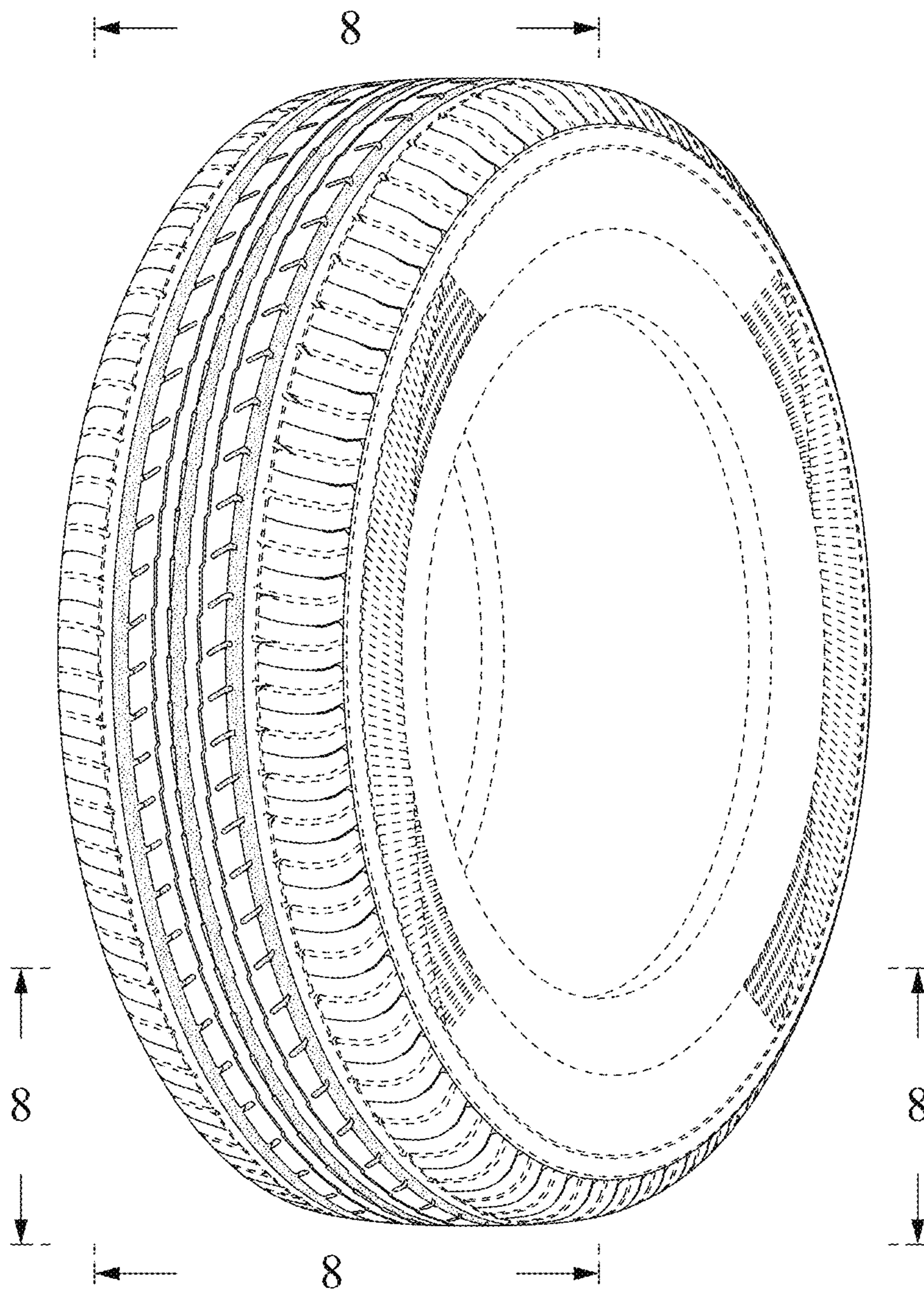

FIG. 2

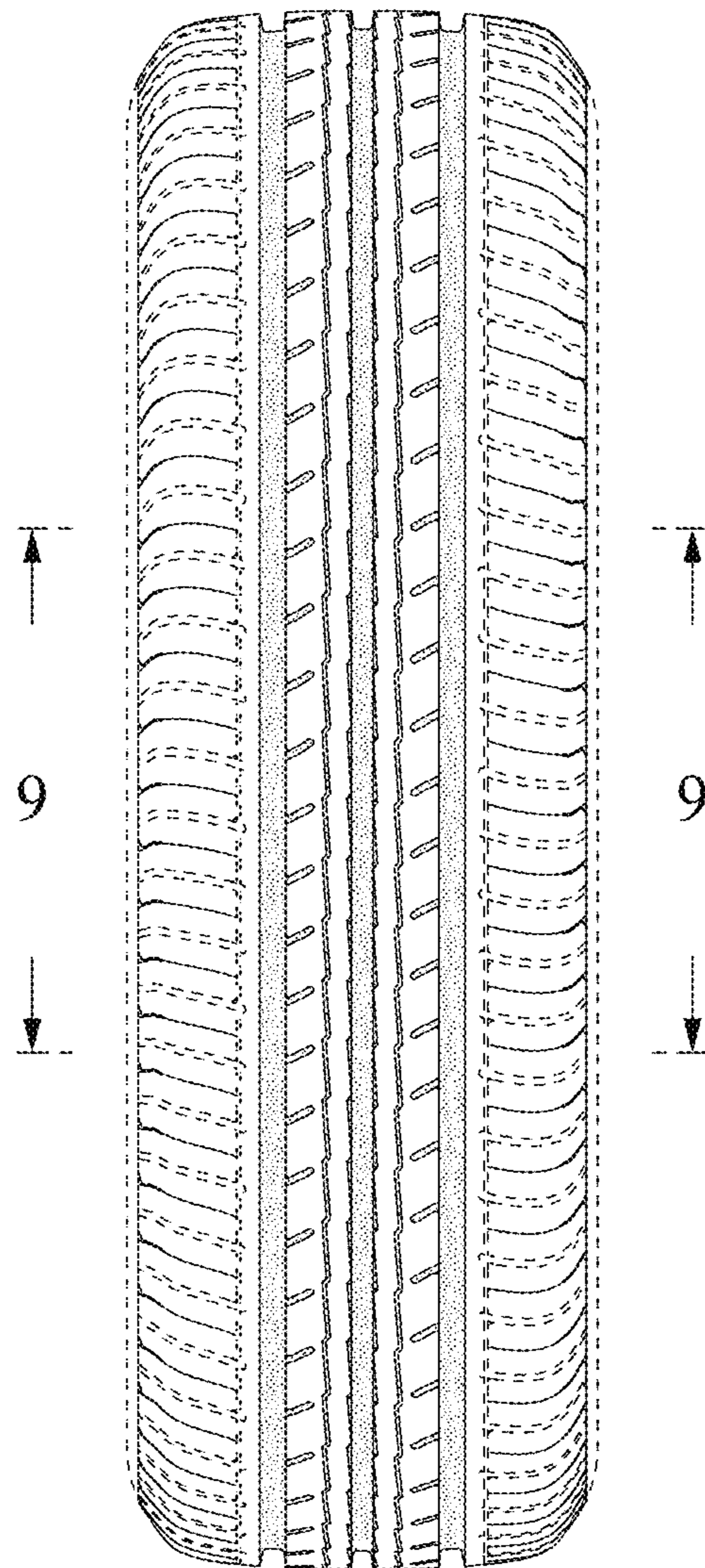

FIG. 3

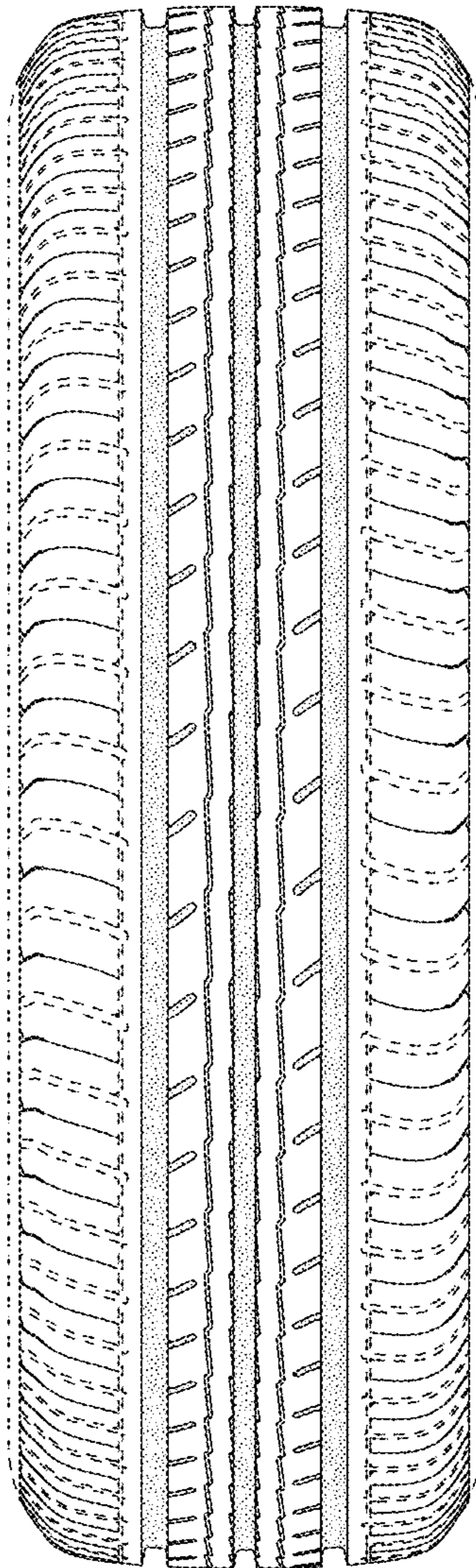

FIG. 4

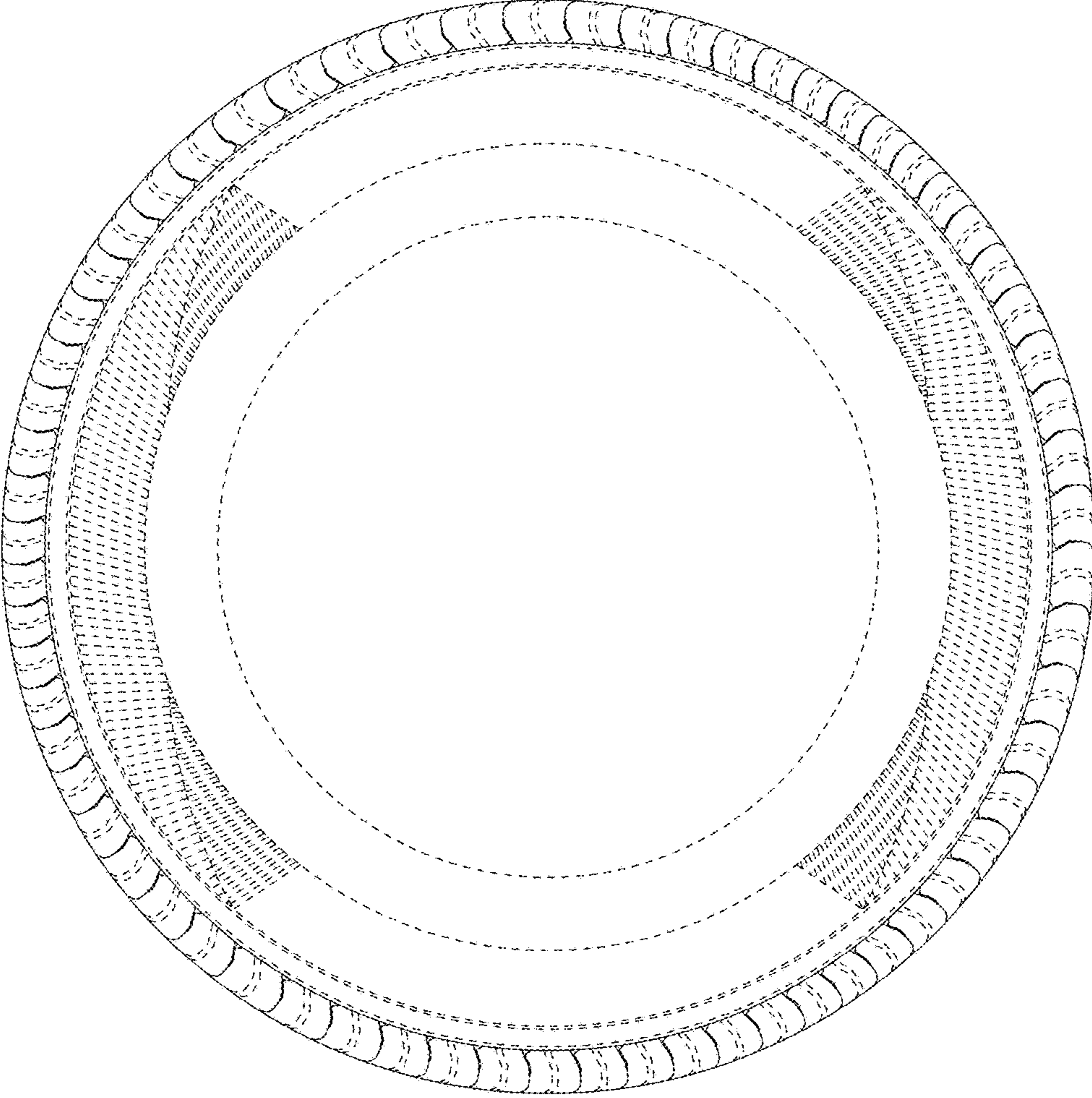

FIG. 5

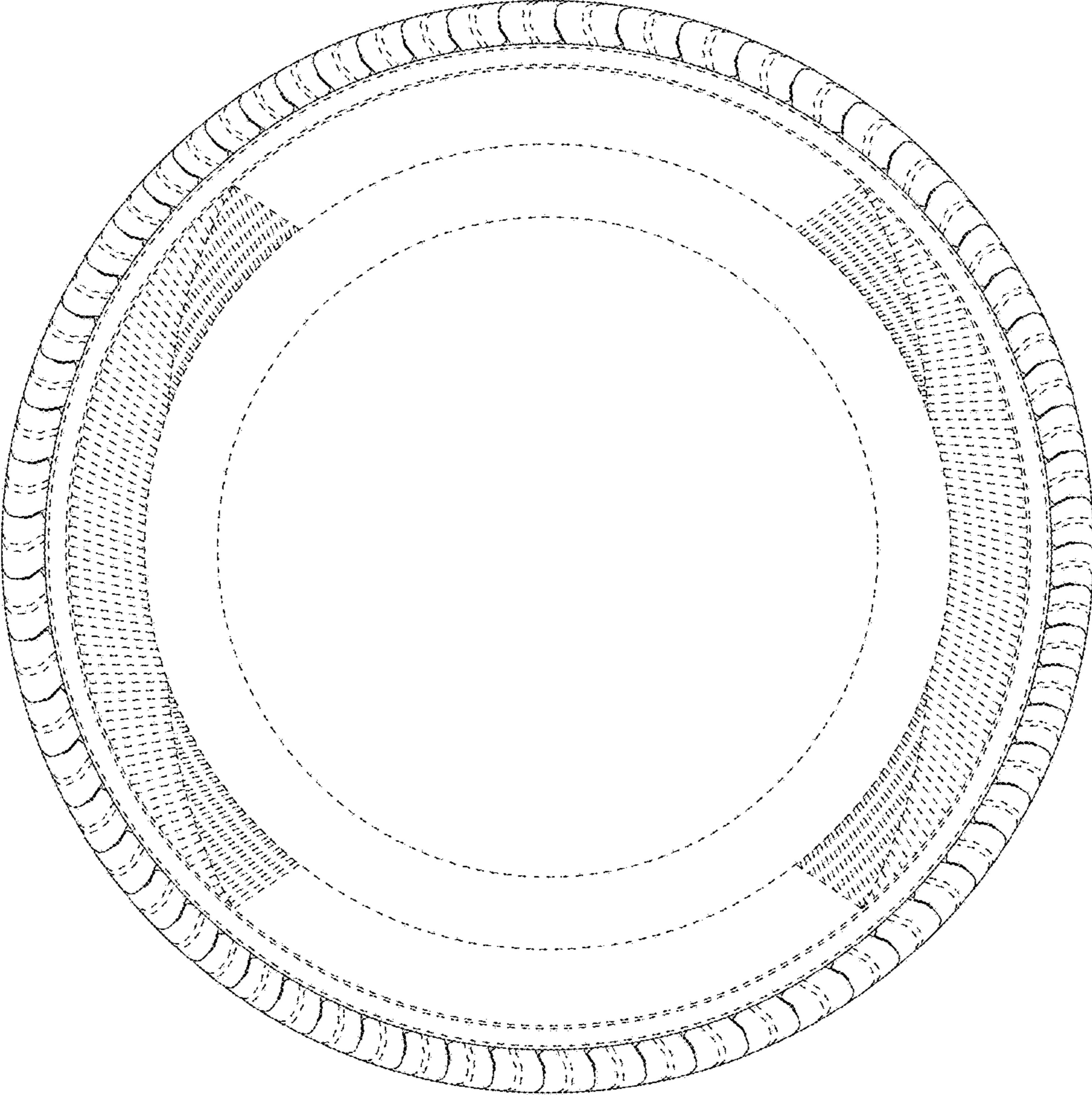

FIG. 6

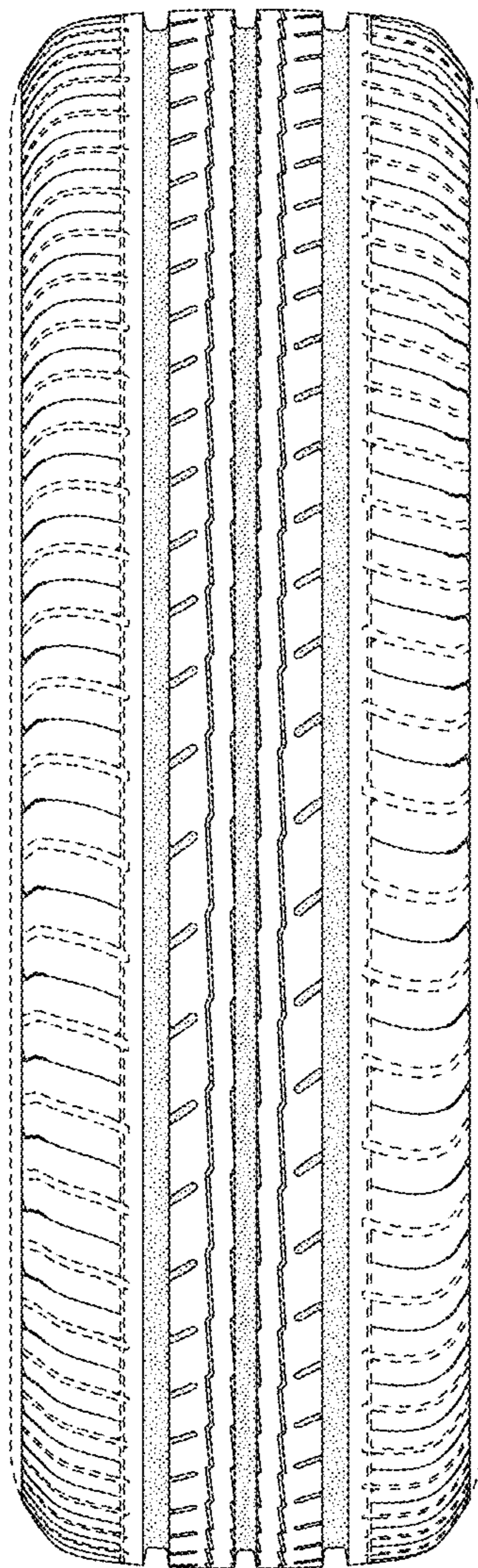

FIG. 7

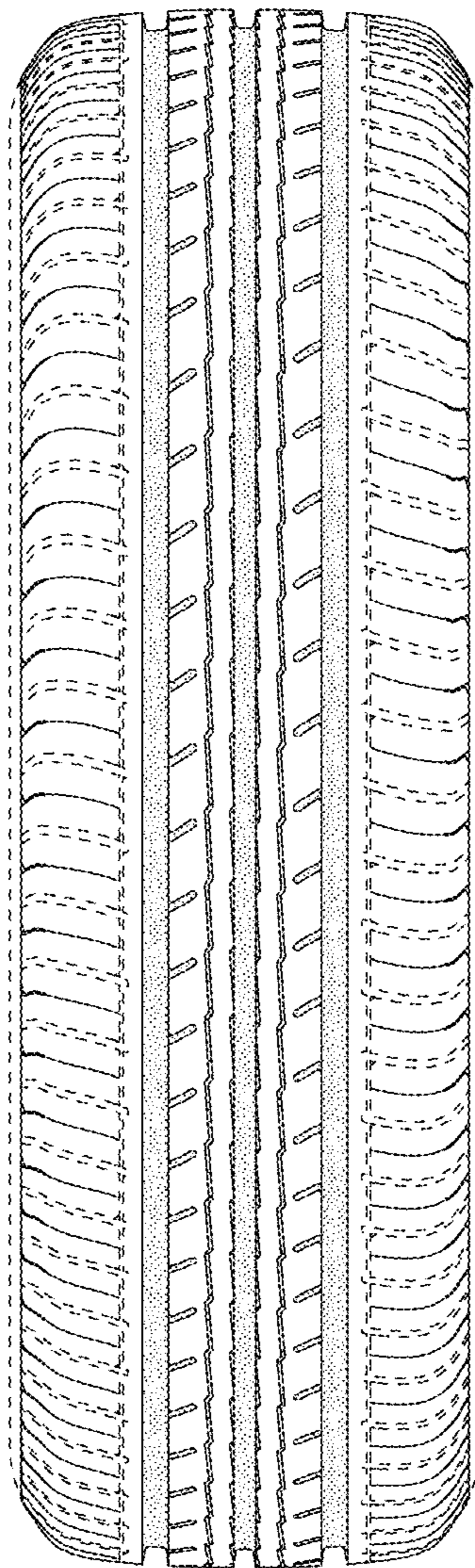

FIG. 8

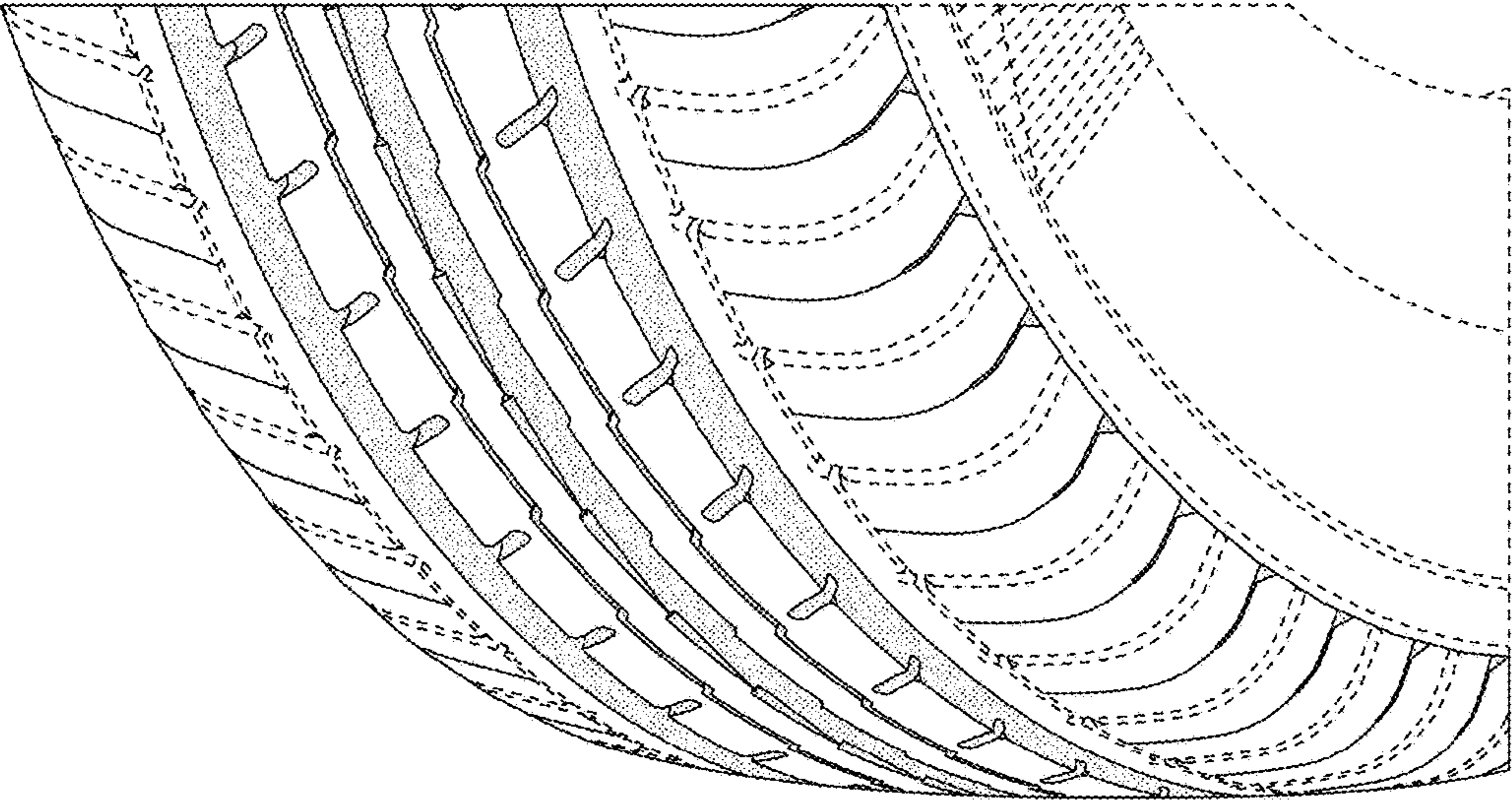

FIG. 9

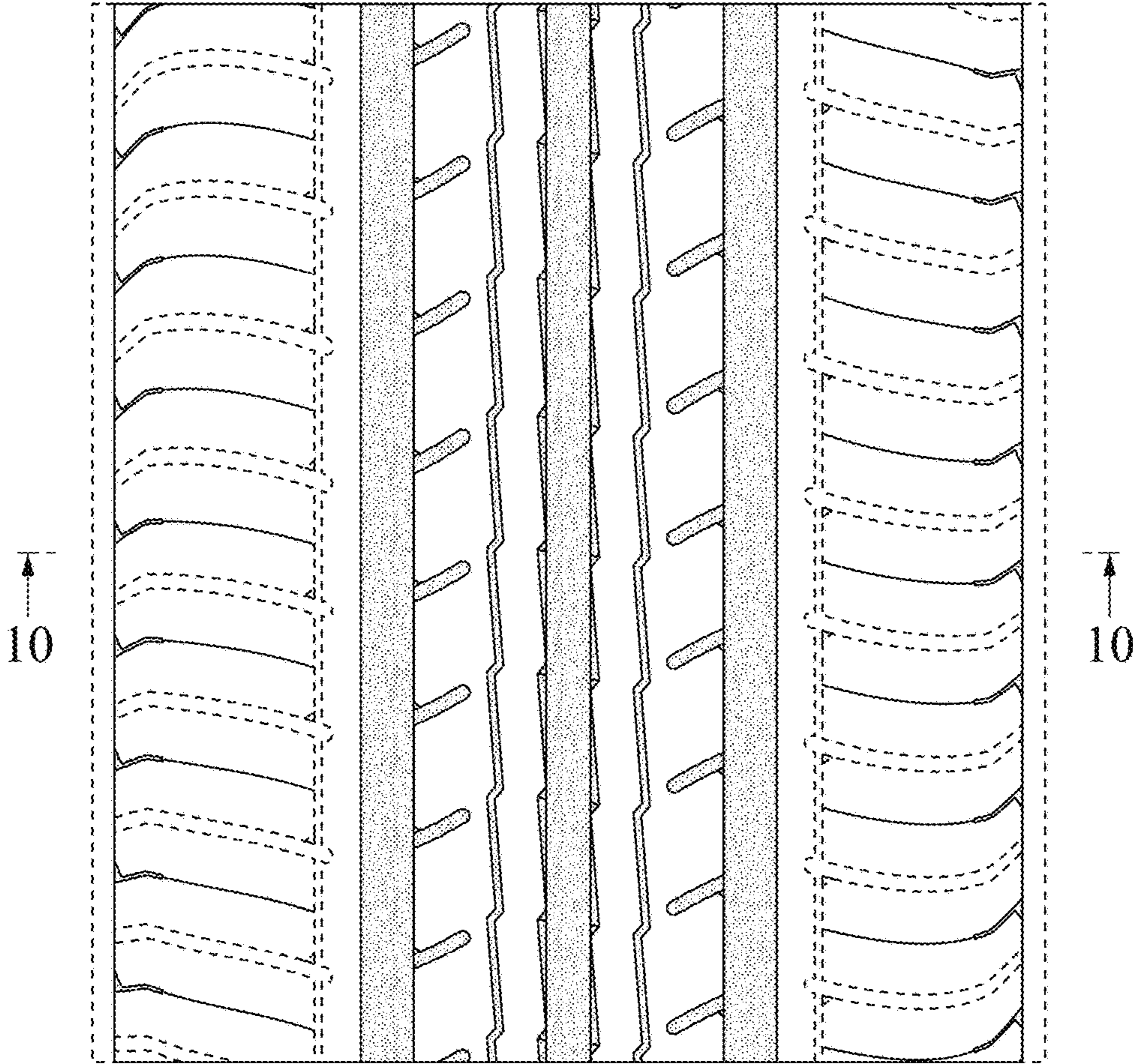

FIG. 10

