



US00D830281S

(12) **United States Design Patent**
Maqbool

(10) **Patent No.:** **US D830,281 S**

(45) **Date of Patent:** **** Oct. 9, 2018**

(54) **UNMANNED VERTICAL TAKEOFF AND LANDING VEHICLE**

(71) Applicant: **North American Wave Engine Corporation**, College Park, MD (US)

(72) Inventor: **Daanish Maqbool**, Hyattsville, MD (US)

(73) Assignee: **NORTH AMERICAN WAVE ENGINE CORPORATION**, College Park, MD (US)

(**) Term: **15 Years**

(21) Appl. No.: **29/616,297**

(22) Filed: **Sep. 5, 2017**

(51) **LOC (11) Cl.** **12-07**

(52) **U.S. Cl.**
USPC **D12/326**

(58) **Field of Classification Search**
USPC D12/16.1, 319-345; D21/436, 441, 442, D21/443, 444, 447-454, 437
CPC B64C 2201/141; B64C 39/024; B64C 2201/127
See application file for complete search history.

(56) **References Cited**

U.S. PATENT DOCUMENTS

D757,859 S *	5/2016	Goitein	D21/453
D759,764 S *	6/2016	Lai	D12/16.1
9,527,588 B1 *	12/2016	Rollefstad	B64C 39/024
D784,854 S *	4/2017	Huang	D12/16.1
D795,785 S *	8/2017	Morrison	D12/16.1
D800,602 S *	10/2017	Hsiao	D12/16.1
D801,223 S *	10/2017	Hsiao	D12/16.1
D808,860 S *	1/2018	Tian	D12/16.1
D809,992 S *	2/2018	Hu	D12/328

D816,582 S *	5/2018	Liang	D12/328
2012/0083945 A1 *	4/2012	Oakley	B64C 27/08 701/2
2014/0339355 A1 *	11/2014	Olm	B64C 27/08 244/17.23
2016/0001879 A1 *	1/2016	Johannesson	B64C 27/50 416/142
2017/0144756 A1 *	5/2017	Rastgaar Aagaah	B64C 39/024
2017/0152035 A1 *	6/2017	Zhao	B64C 39/024
2017/0210470 A1 *	7/2017	Pardell	B64C 39/024
2017/0297707 A1 *	10/2017	Rollefstad	B64C 39/024
2018/0065735 A1 *	3/2018	Ichihara	B64C 27/08

* cited by examiner

Primary Examiner — Brandon M Rosati

Assistant Examiner — Marissa J Cash

(74) *Attorney, Agent, or Firm* — Wilmer Cutler Pickering Hale and Dorr LLP

(57) **CLAIM**

The ornamental design for an unmanned vertical takeoff and landing vehicle, as shown and described.

DESCRIPTION

FIG. 1 is a top, rear, left side perspective view of an unmanned vertical takeoff and landing vehicle showing my new design;

FIG. 2 is a front elevational view thereof;

FIG. 3 is a rear elevational view thereof;

FIG. 4 is a left side elevational view thereof;

FIG. 5 is a right side elevational view thereof;

FIG. 6 is a top plan view thereof; and,

FIG. 7 is a bottom elevational view thereof.

The broken lines shown in the drawings depict portions of the unmanned vertical takeoff and landing vehicle that form no part of the claimed design.

1 Claim, 6 Drawing Sheets

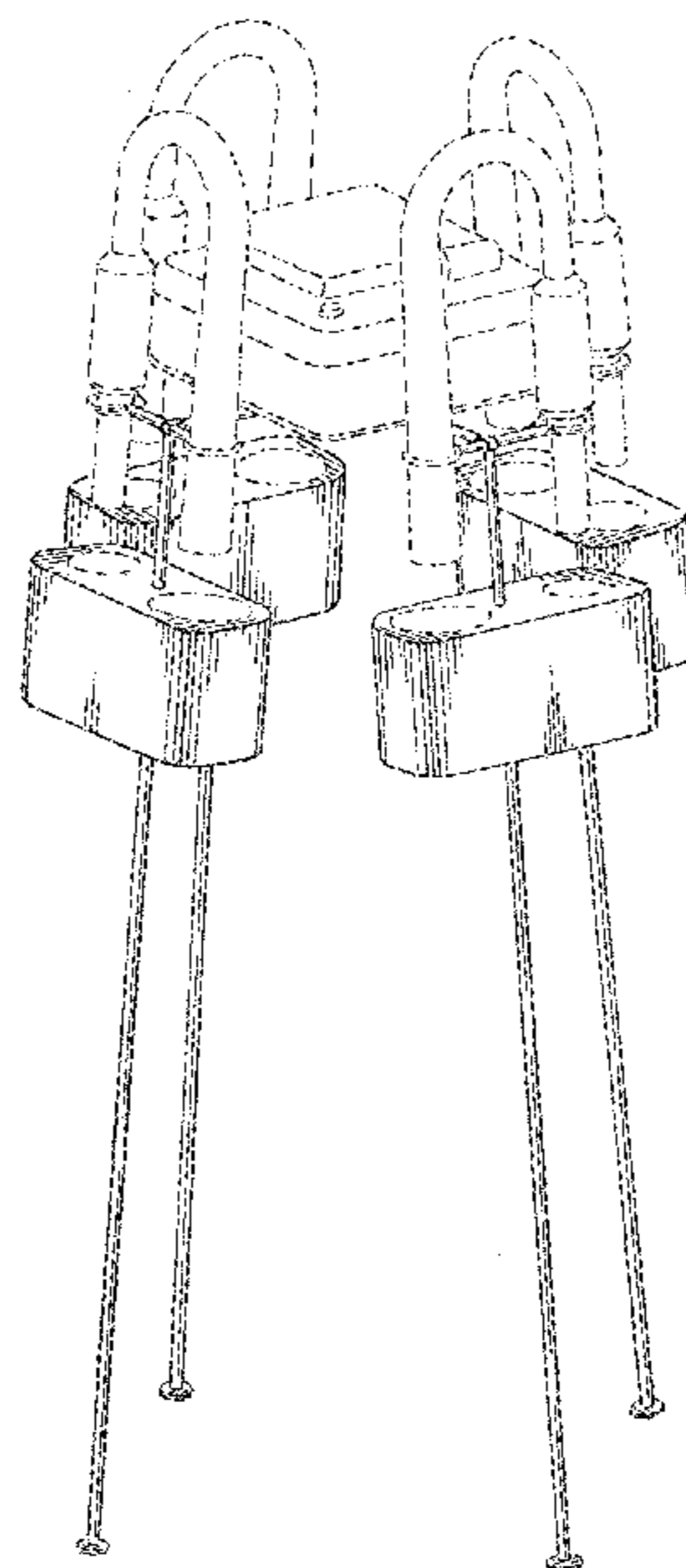

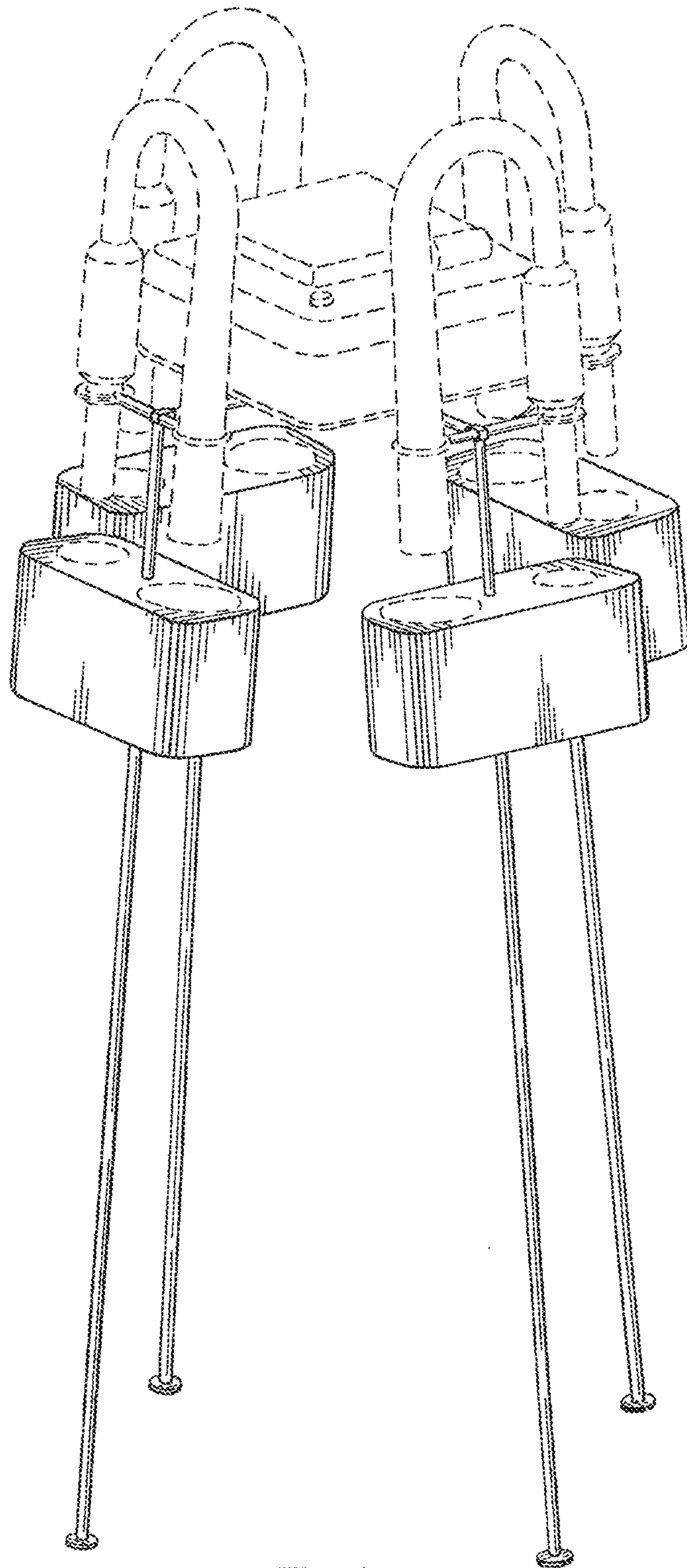

Fig. 1

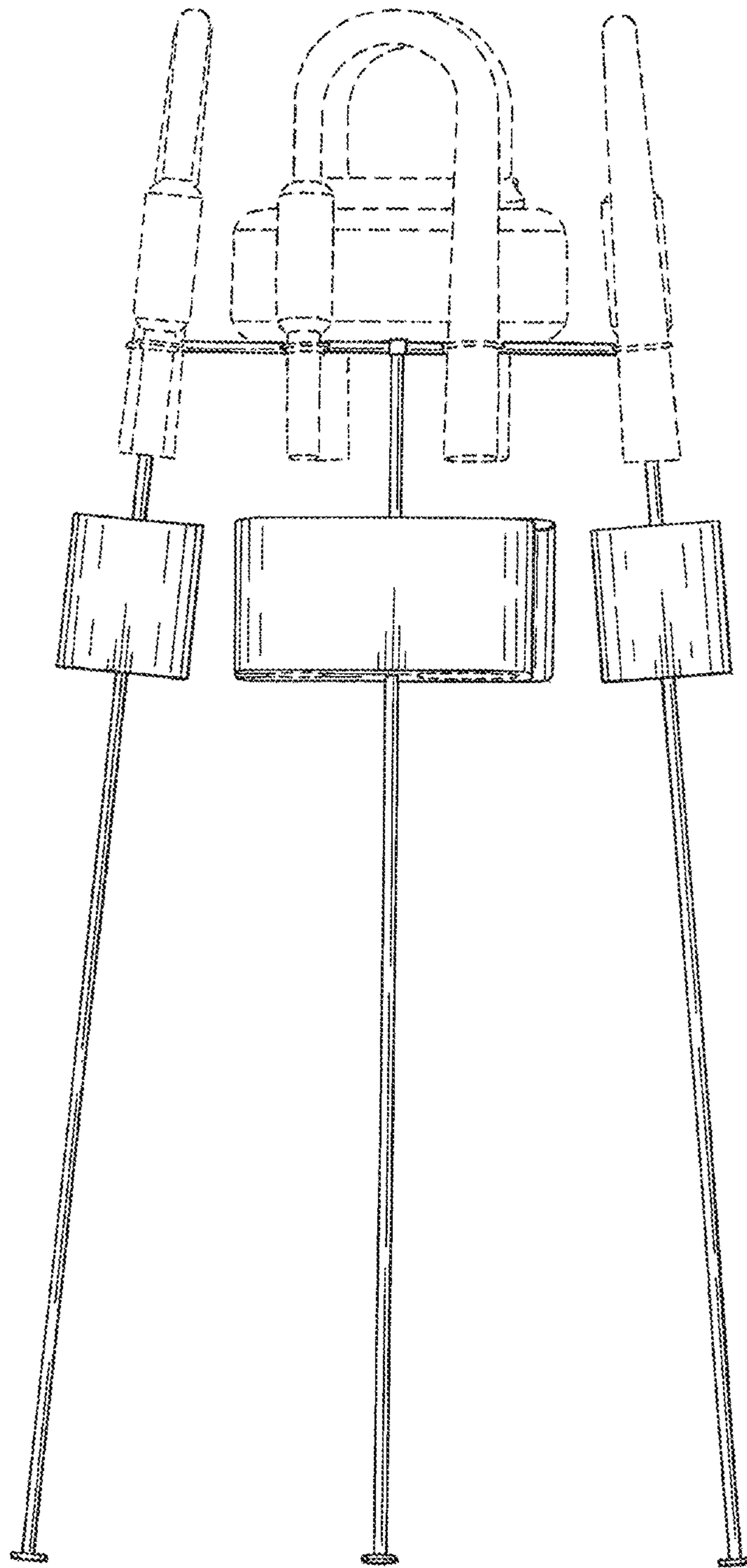

Fig. 2

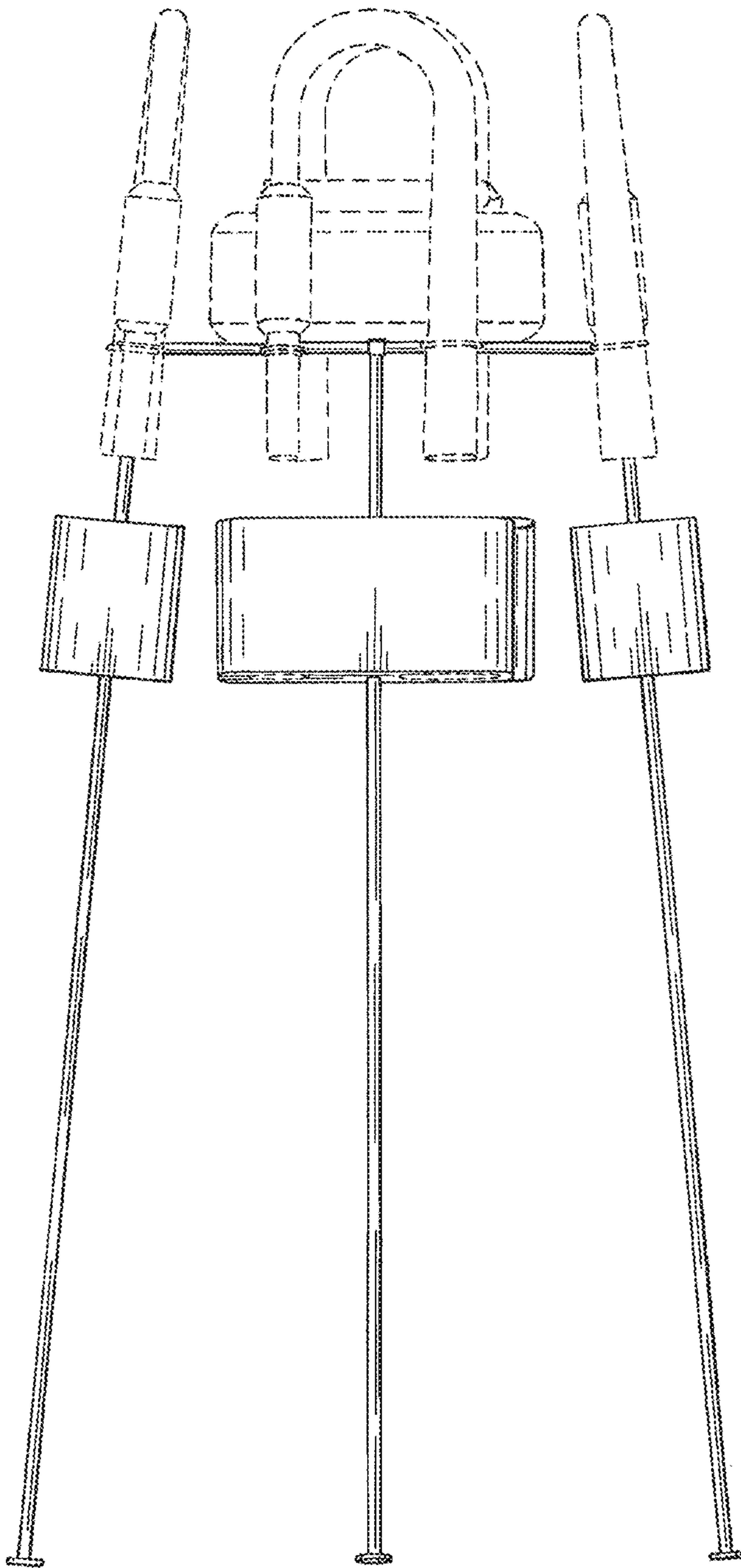

Fig. 3

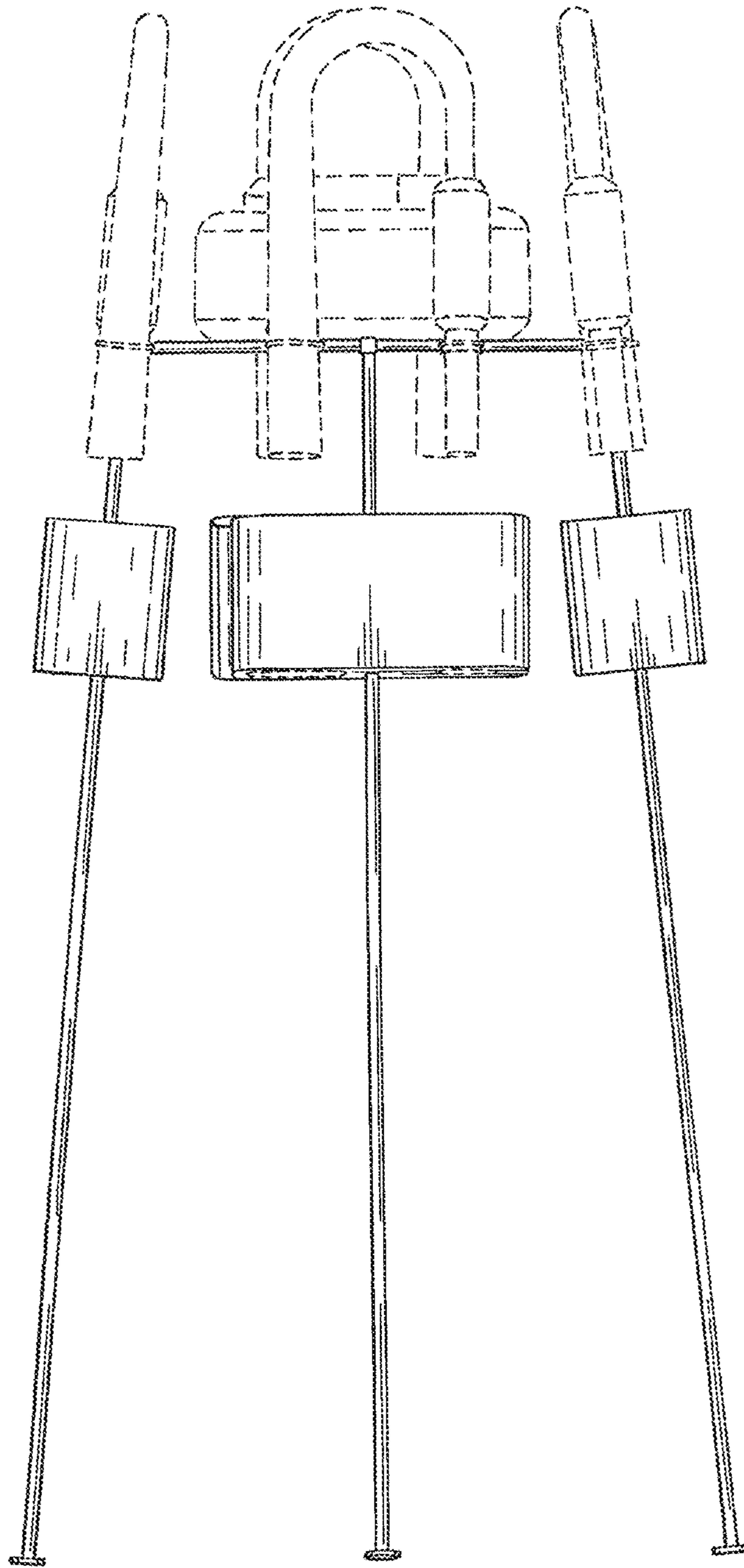

Fig. 4

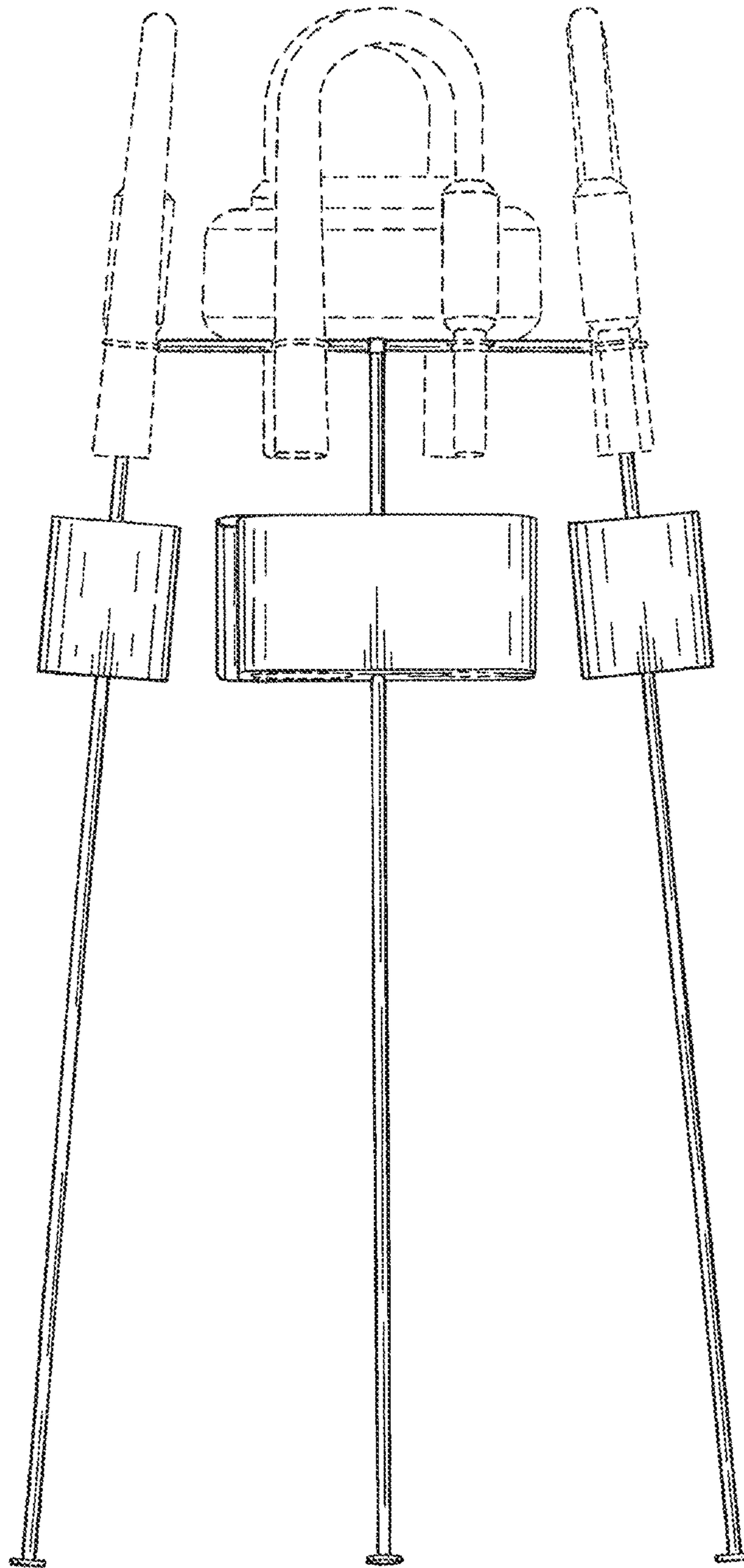

Fig. 5

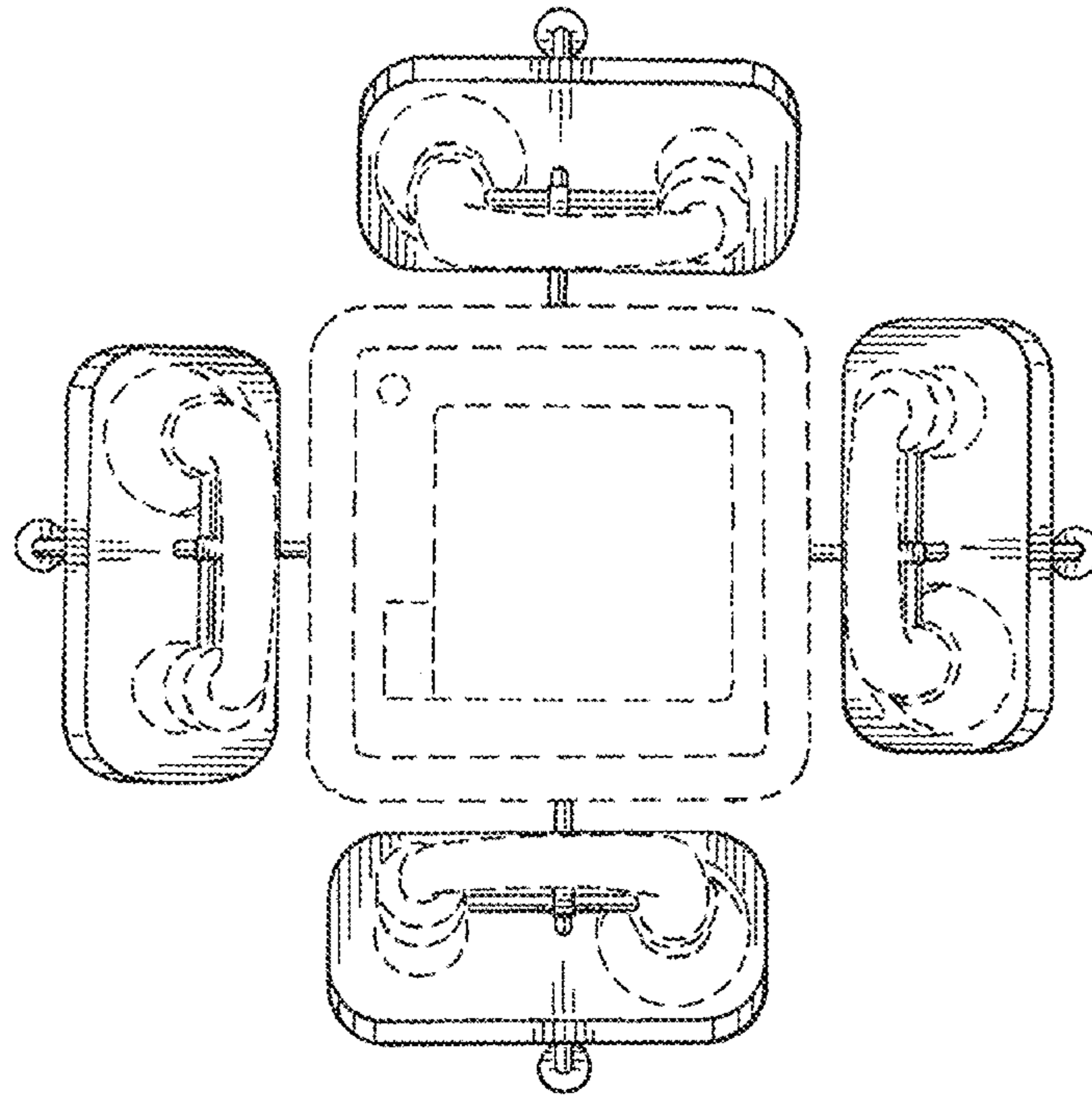

Fig. 6

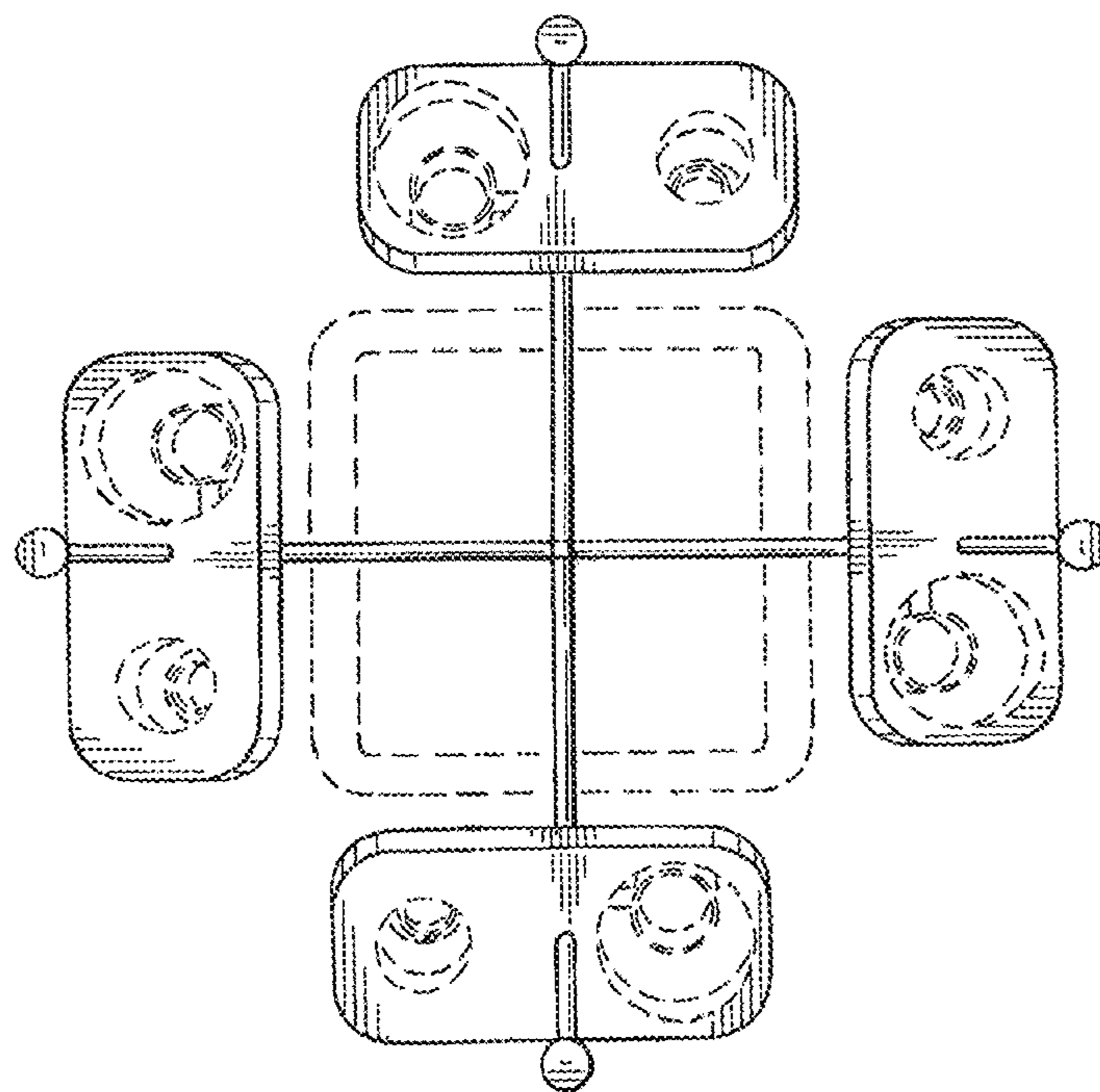

Fig. 7