



US00D830056S

(12) **United States Design Patent** (10) **Patent No.:** **US D830,056 S**  
**Cunningham** (45) **Date of Patent:** **\*\* Oct. 9, 2018**

(54) **SIDE HARDBAG FOR A MOTORCYCLE**

(71) Applicant: **Evil Empire Designs, Inc.**, Henderson, NV (US)

(72) Inventor: **Sheila Cunningham**, Henderson, NV (US)

(73) Assignee: **Evil Empire Designs, Inc.**, Henderson, NV (US)

(\*\*) Term: **15 Years**

(21) Appl. No.: **29/584,909**

(22) Filed: **Nov. 18, 2016**

(51) **LOC (11) Cl.** ..... **03-01**

(52) **U.S. Cl.**

USPC ..... **D3/231**

(58) **Field of Classification Search**

USPC ..... D3/201, 205, 206, 226, 231–247, 258, D3/273, 299, 301, 303, 318, 901, 903, D3/203.1, 203.6, 203.2, 215, 221, 254; D12/409, 410, 407, 114

CPC ..... A45C 15/00; A45C 13/02; A45C 3/00; A45C 3/02; A45C 3/04; A45C 9/00

See application file for complete search history.

(56) **References Cited**

**U.S. PATENT DOCUMENTS**

|             |           |             |         |
|-------------|-----------|-------------|---------|
| 4,379,703 A | 4/1983    | Mizell      |         |
| D385,416 S  | * 10/1997 | Runner      | D3/231  |
| D387,628 S  | * 12/1997 | Keene       | D3/246  |
| D433,798 S  | * 11/2000 | Weinstock   | D3/215  |
| D482,521 S  | * 11/2003 | Taylor      | D3/215  |
| D506,968 S  | * 7/2005  | Berardino   | D12/410 |
| D600,190 S  | * 9/2009  | Sharpe, Jr. | D12/410 |
| D601,793 S  | * 10/2009 | Sartor      | D3/201  |
| D675,557 S  | * 2/2013  | Harris      | D12/410 |

(Continued)

**OTHER PUBLICATIONS**

Triumphrat, Bonneville saddle bags and braces, posted on Jul. 9, 2009, [online], [site visited Feb. 13, 2018]. Available from Internet, <URL: <http://www.triumphrat.net/air-cooled-twins-technical-talk/109695-new-hard-bags-on-bonnie-6.html#post1313934>> (Year: 2009).\*

(Continued)

*Primary Examiner* — Sheryl Lane

*Assistant Examiner* — Samantha N Wood

(74) *Attorney, Agent, or Firm* — Patterson Thuent Pedersen, P.A.

(57) **CLAIM**

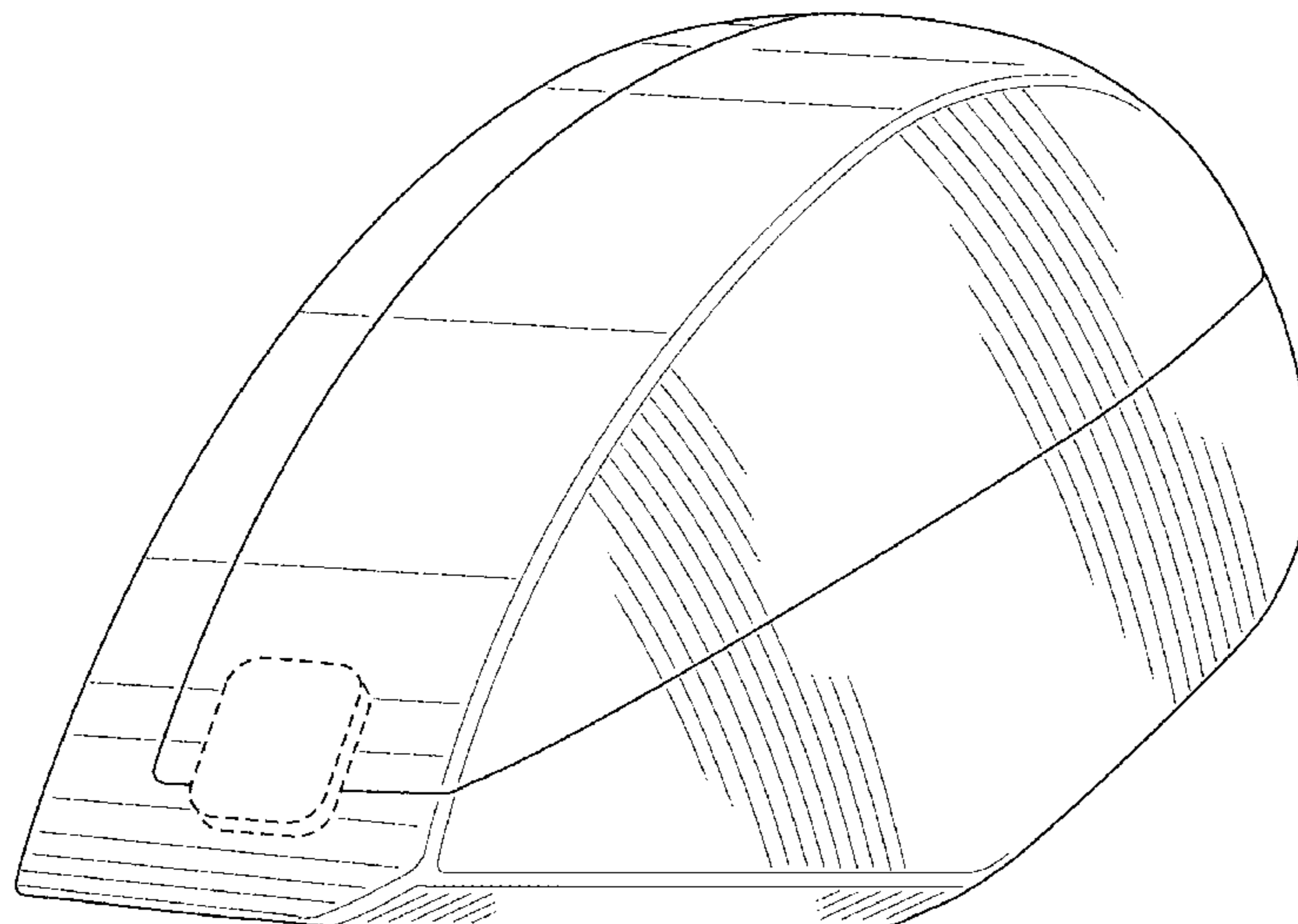
The ornamental design for a side hardbag for a motorcycle, as shown and described.

**DESCRIPTION**

FIG. 1, is a perspective view of a left side hardbag for a motorcycle according to the invention; FIG. 2, is a side view thereof; FIG. 3, is a reverse side view thereof; FIG. 4, is a top view thereof; FIG. 5, is a bottom view thereof; FIG. 6 is a front view thereof; FIG. 7 is a back view thereof; and FIG. 8 is an isometric view of the side hardbag for a motorcycle as it would appear in an exemplary environment. FIG. 9 is a perspective view of a right side hardbag for a motorcycle according to the invention; FIG. 10 is a side view thereof; FIG. 11 is a reverse side view thereof; FIG. 12 is a top view thereof; FIG. 13 is a bottom view thereof; FIG. 14 is a front view thereof; and, FIG. 15 is a back view thereof.

The broken lines shown in the drawings represent portions of the invention that form no part of the claimed design.

**1 Claim, 11 Drawing Sheets**



(56)

**References Cited**

U.S. PATENT DOCUMENTS

|              |         |                |          |
|--------------|---------|----------------|----------|
| D703,781 S   | 4/2014  | Durante et al. |          |
| D705,373 S   | 5/2014  | Durante et al. |          |
| D705,881 S   | 5/2014  | Durante et al. |          |
| D709,688 S * | 7/2014  | Farco .....    | D3/203.2 |
| D711,093 S * | 8/2014  | Alamdar .....  | D3/231   |
| D743,163 S * | 11/2015 | Alamdar .....  | D3/231   |
| D797,445 S * | 9/2017  | Boroski .....  | D3/243   |

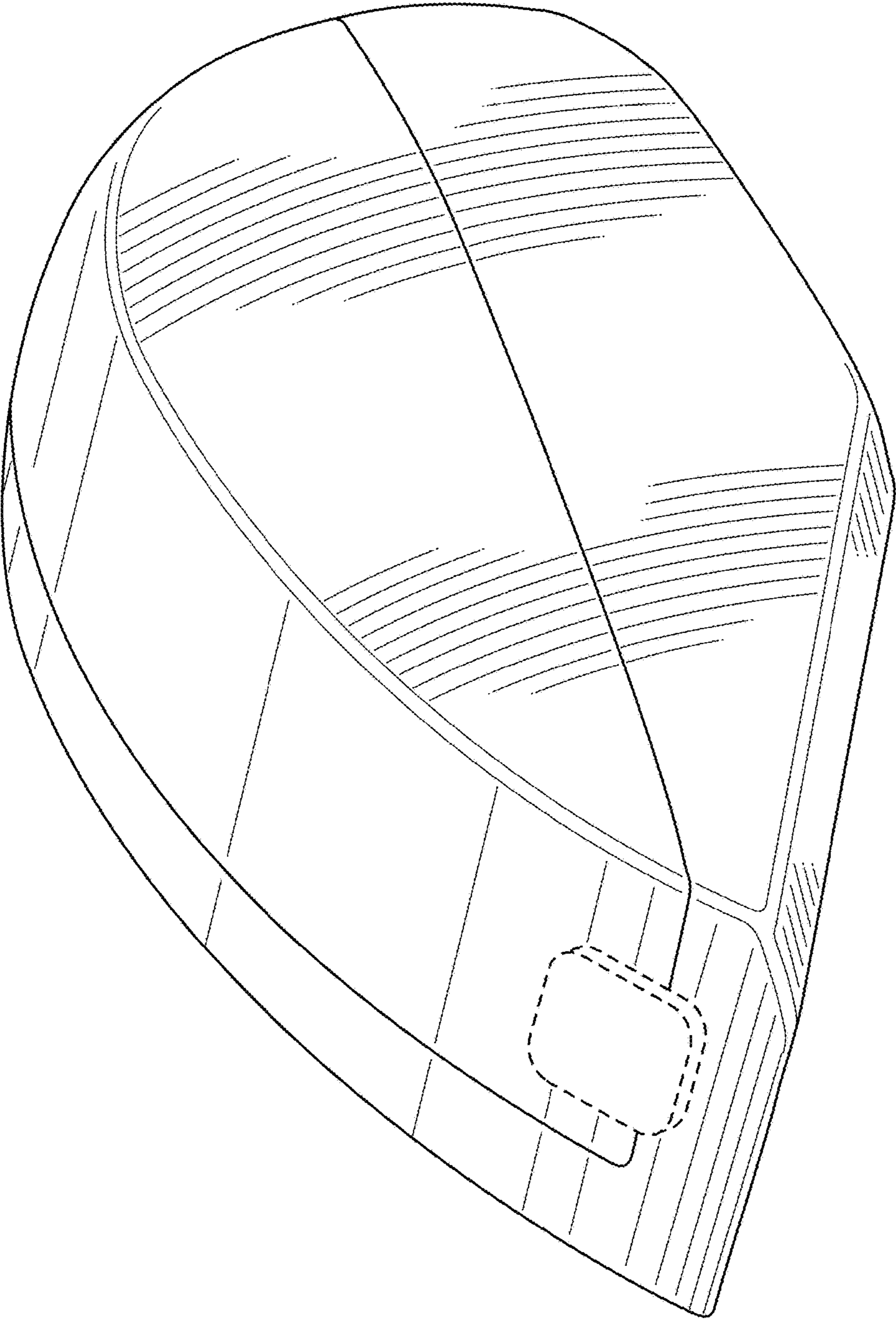
OTHER PUBLICATIONS

Tsukayu, Hard Saddlebags for VSTAR, webarchive Jan. 19, 2010, [online], [site visited Feb. 13, 2018]. Available from Internet, <URL: <https://web.archive.org/web/20100119184652/https://www.tsukayu.com/HardbagsforVstar.html>> (Year: 2010).\*

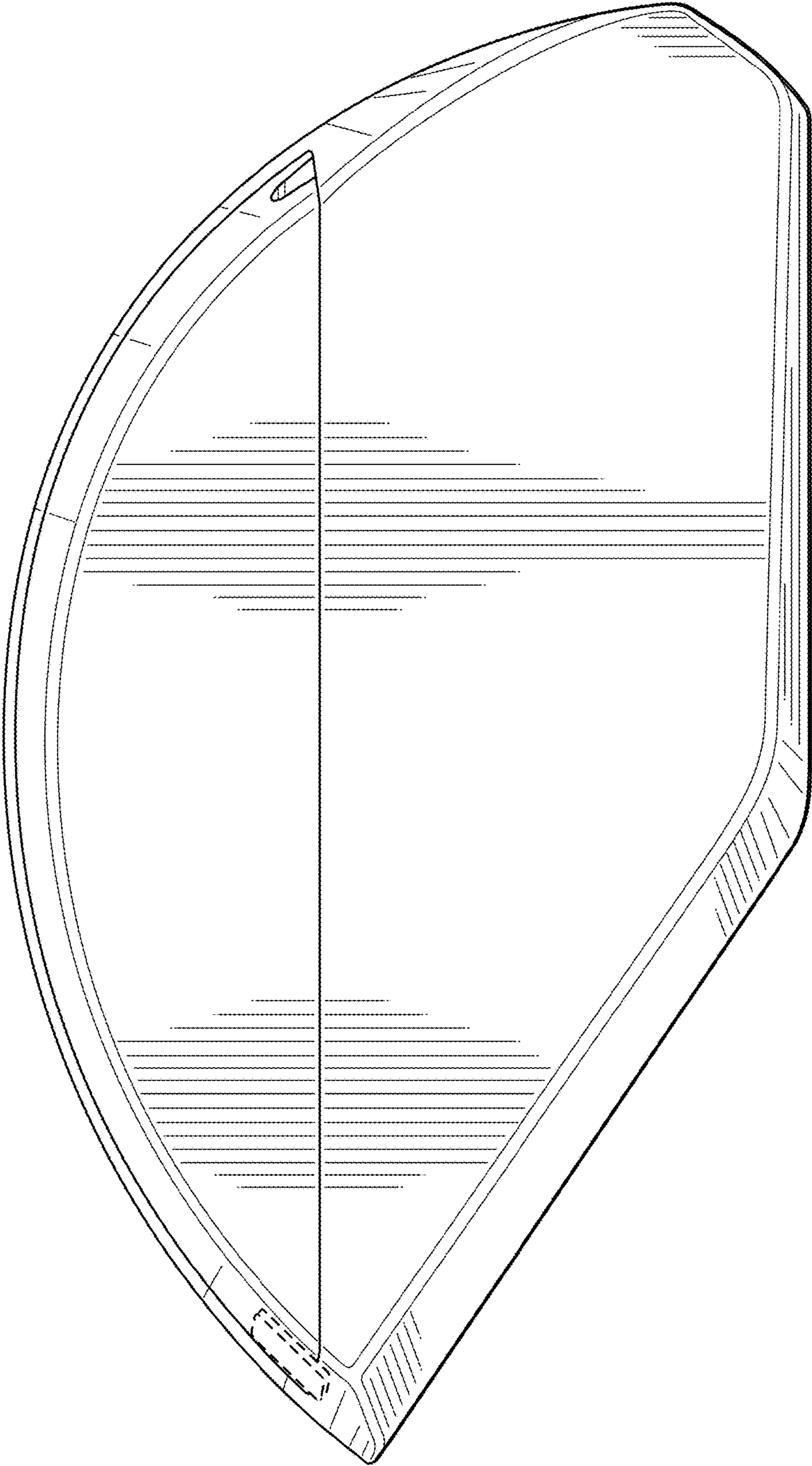
Value Accessories, Tsukayu Honda VTX Fiberglass Hard Bags, webarchive Feb. 9, 2016, [online], [site visited May 15, 2018]. Available from Internet, <URL: <https://web.archive.org/web/20160209031917/https://store.valueaccessories.net/TsukayuHondaVTXFiberglassHardBags.aspx>> (Year: 2016).\*

\* cited by examiner

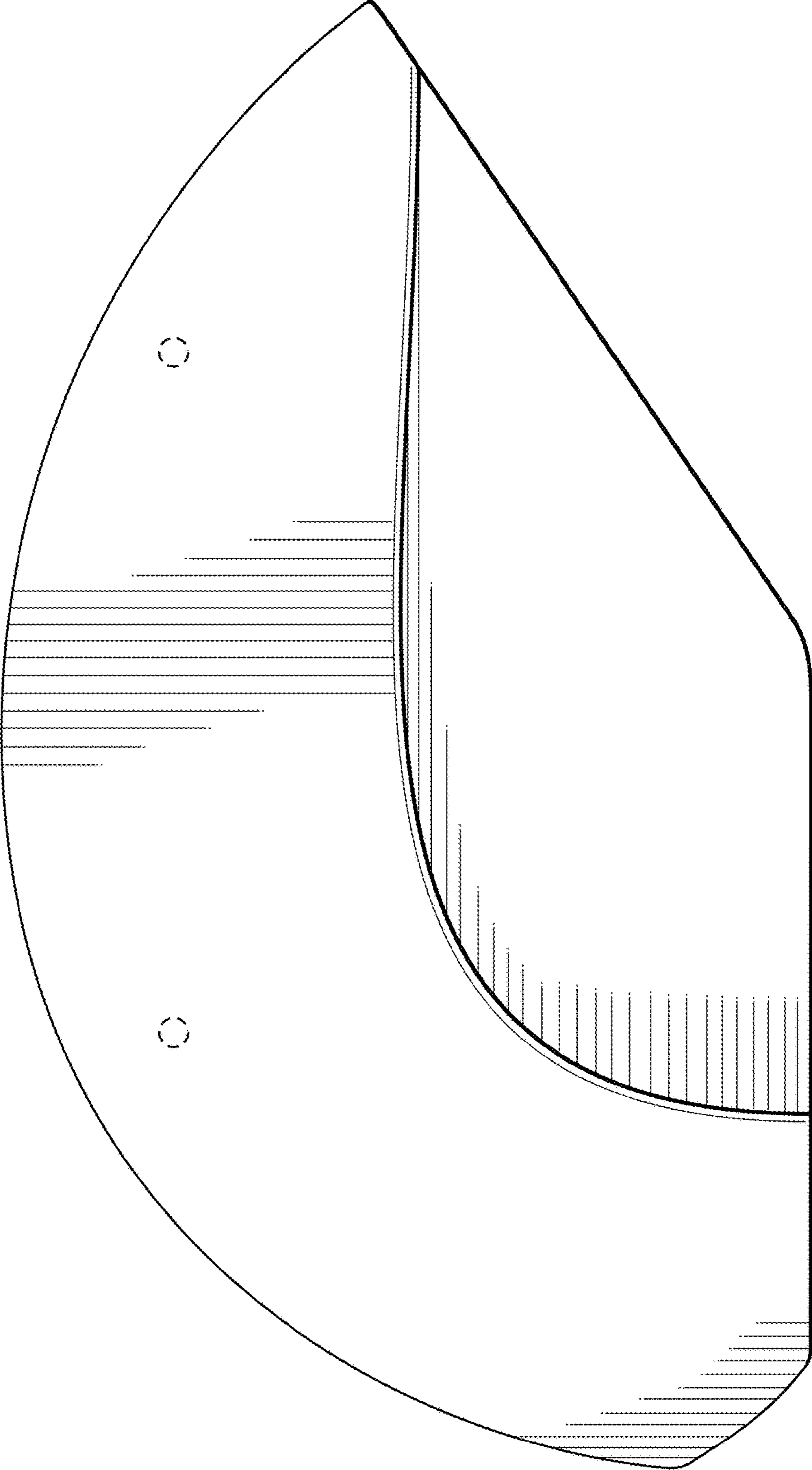
**Fig. 1**



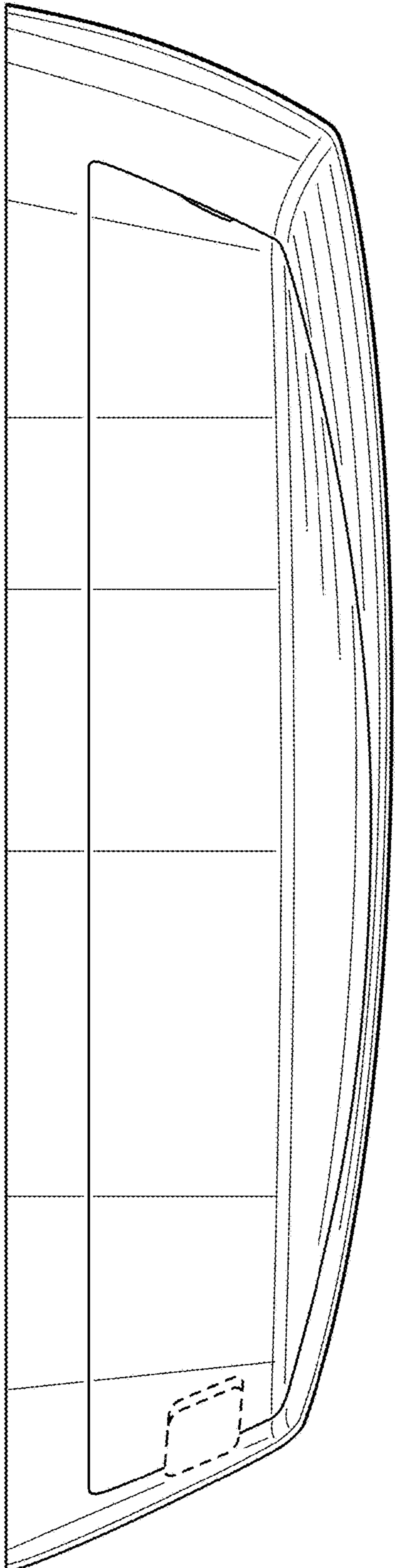
**Fig. 2**



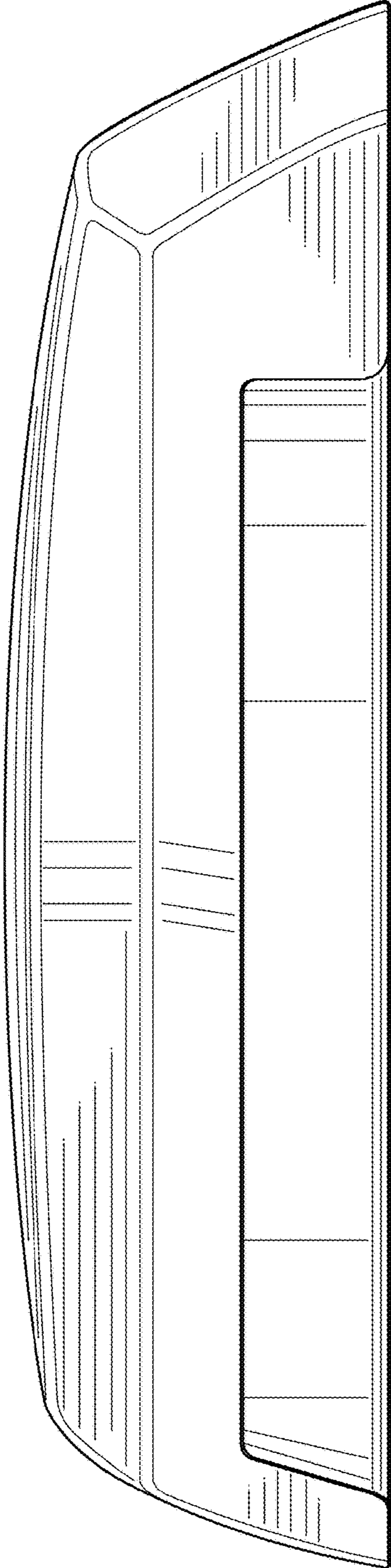
**Fig. 3**



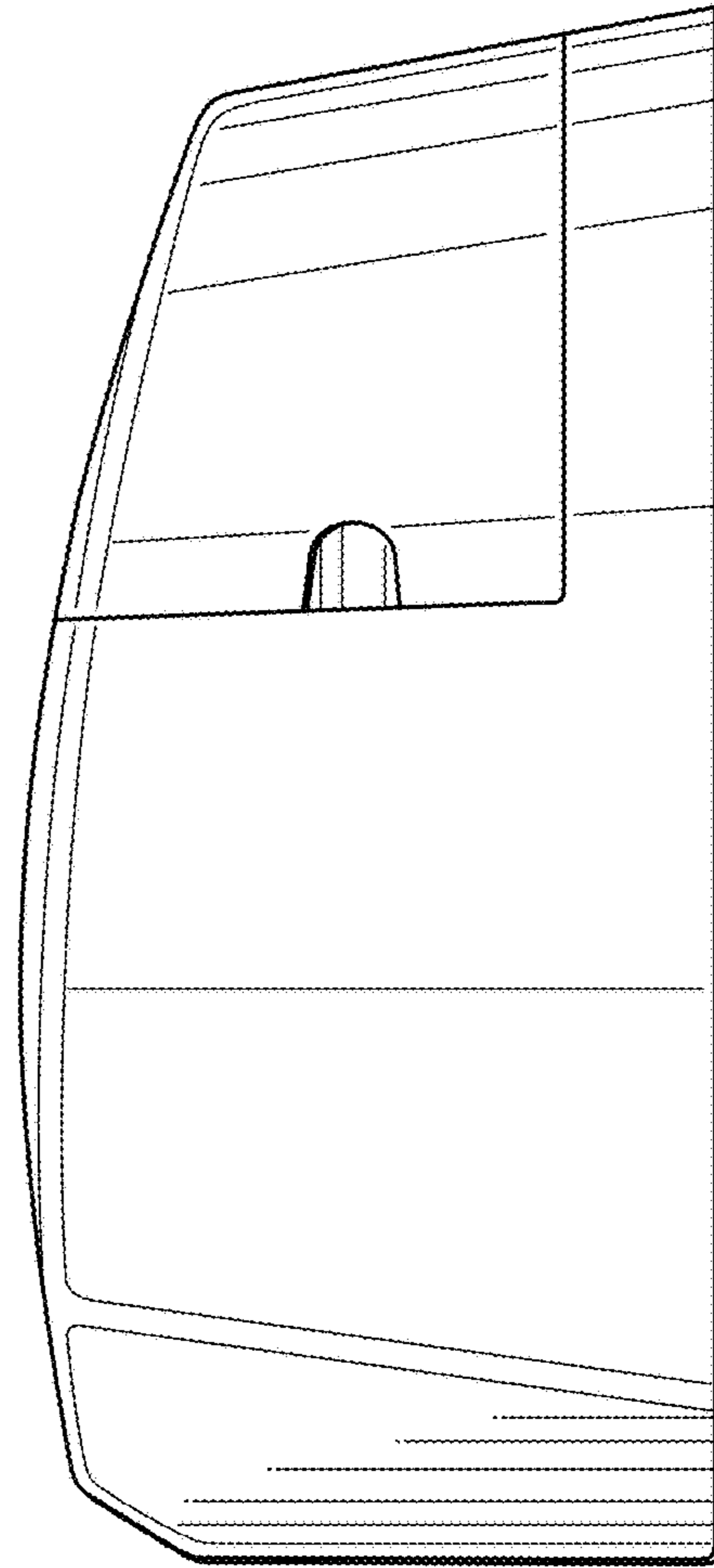
**Fig. 4**



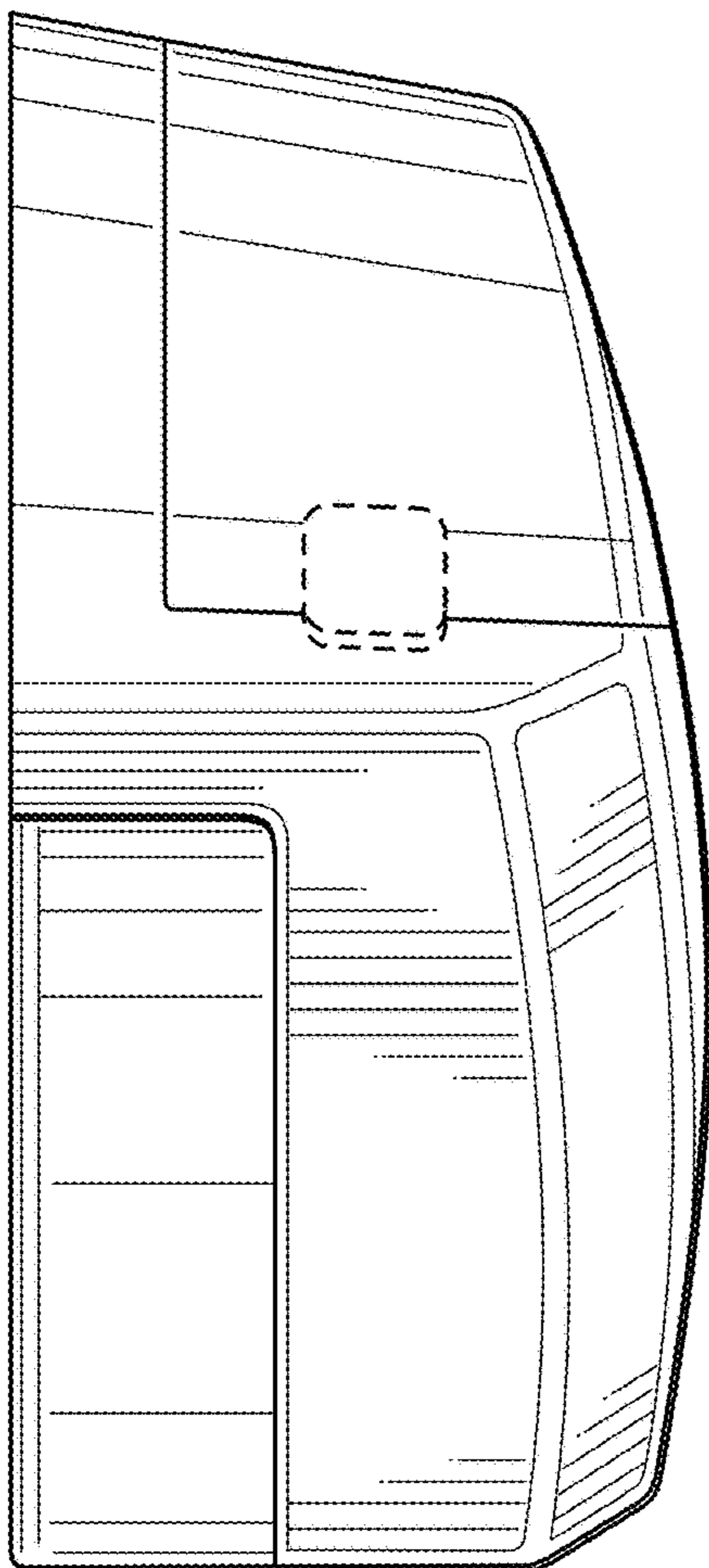
**Fig. 5**

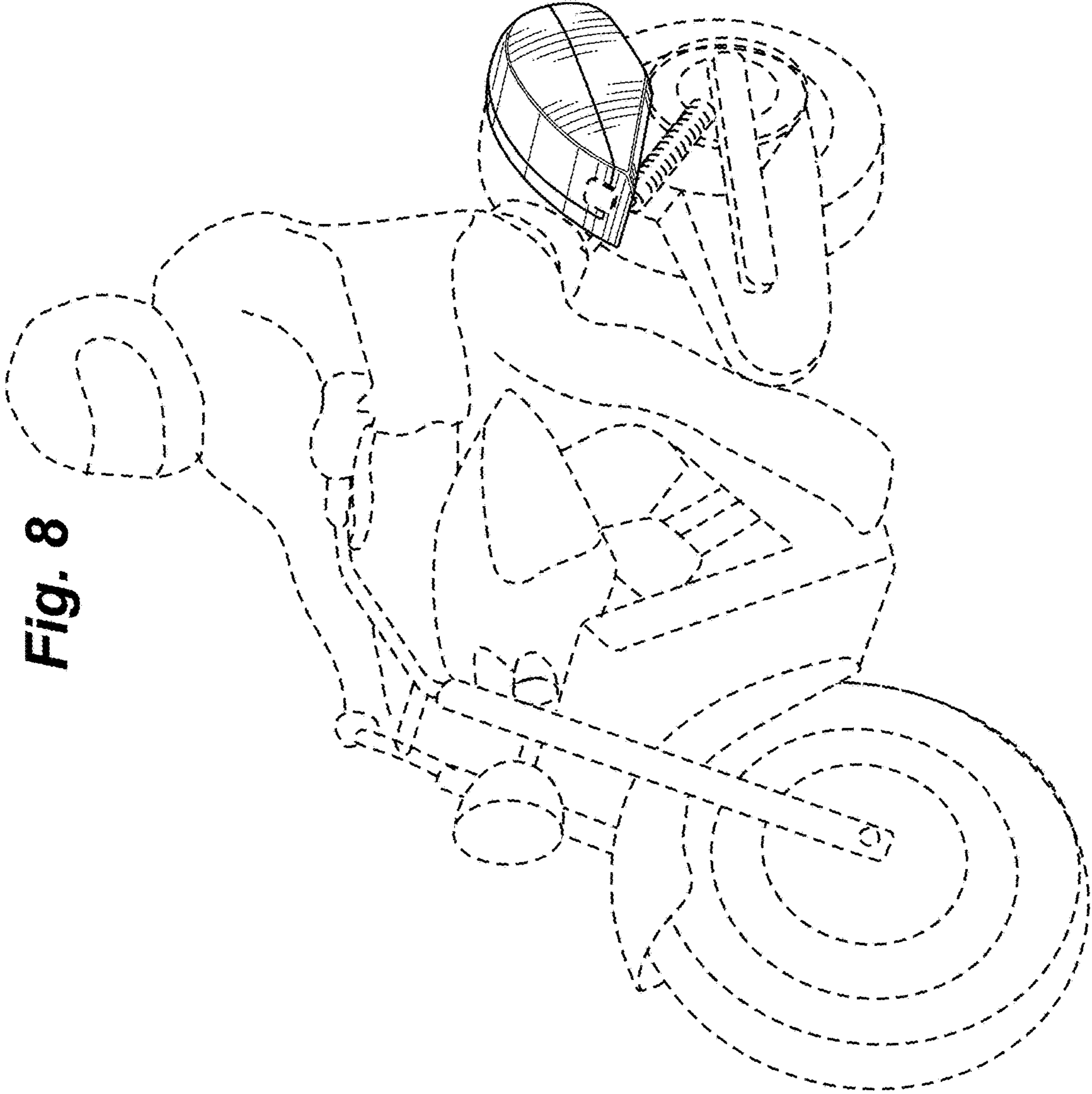


**Fig. 6**



**Fig. 7**

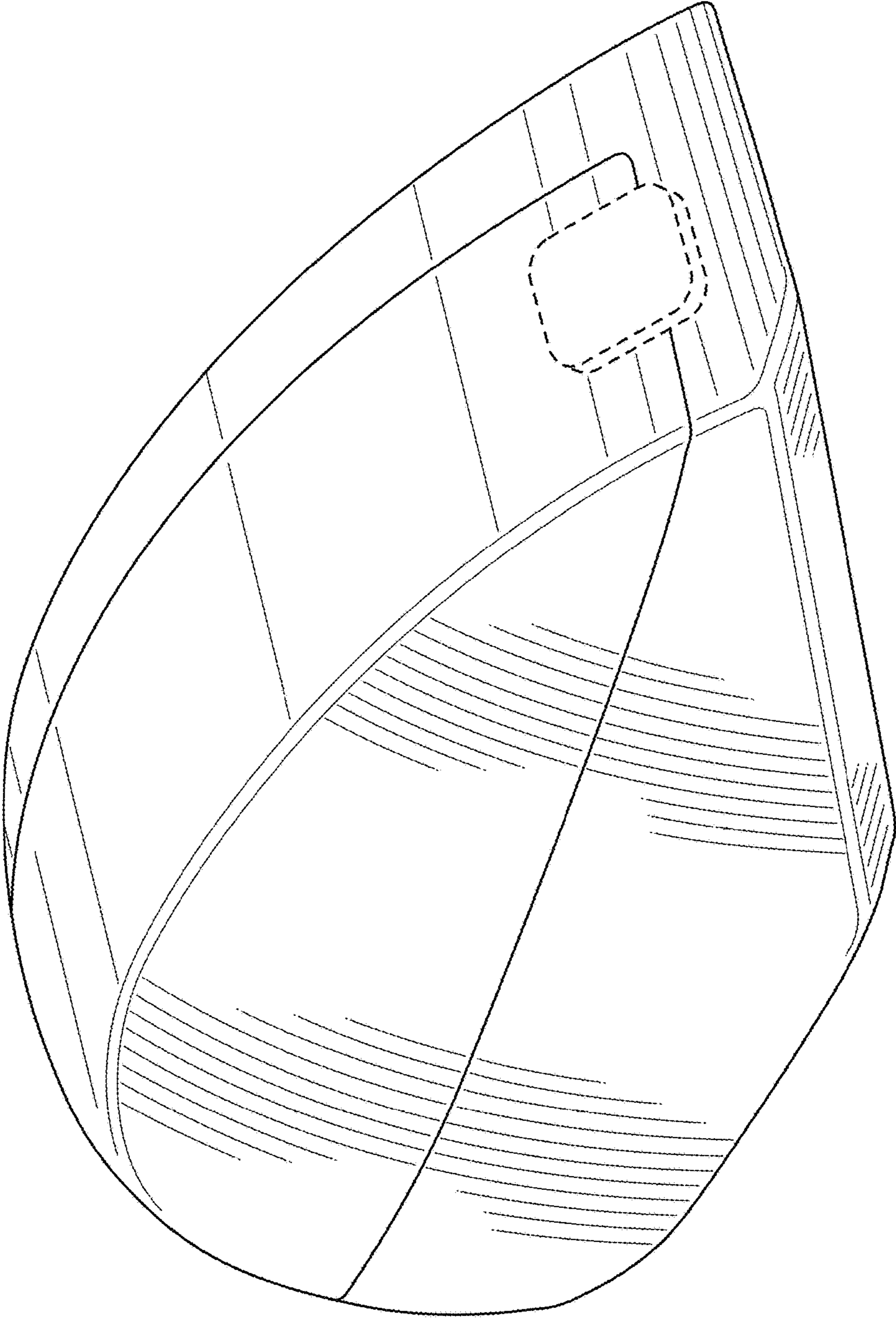




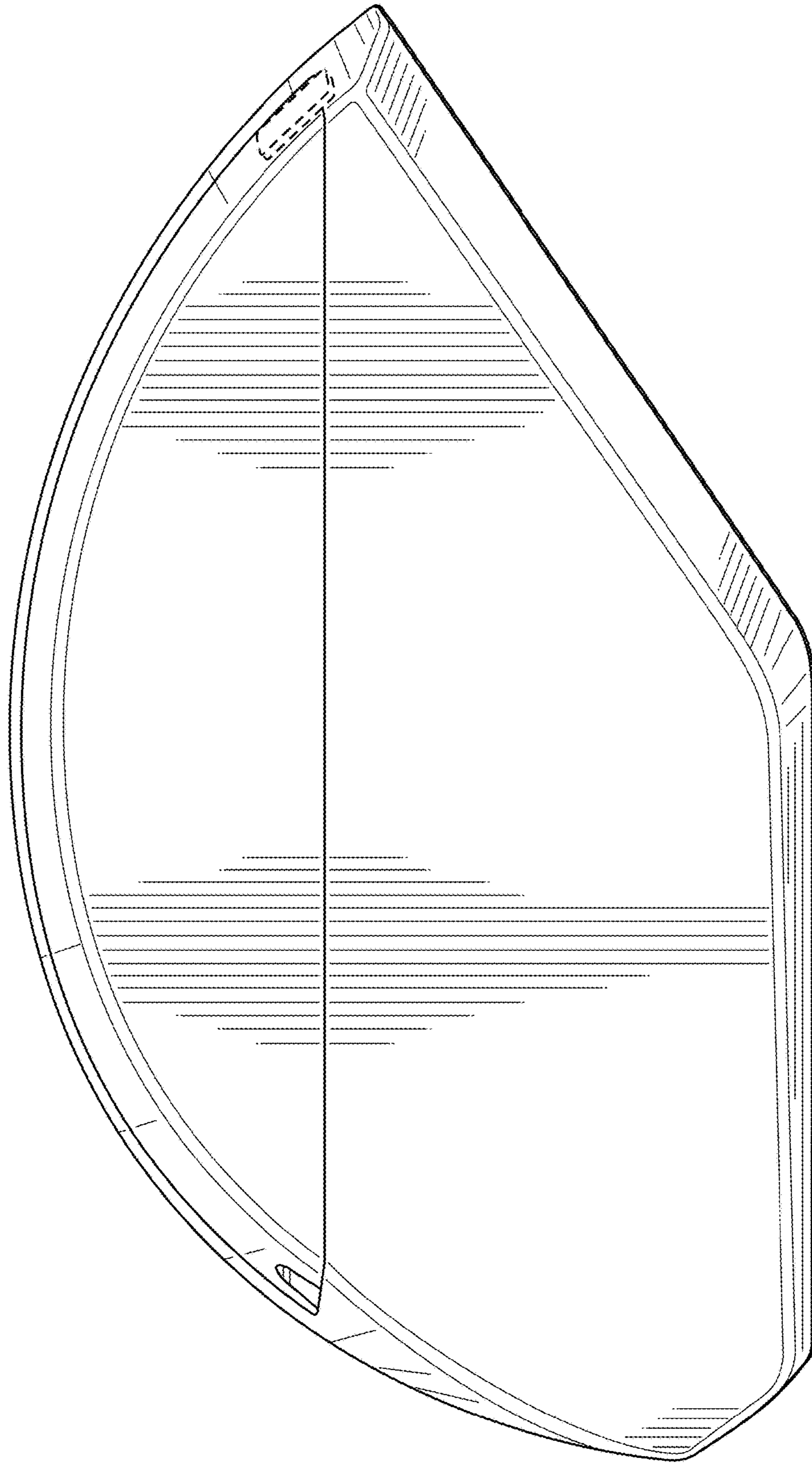
**Fig. 8**



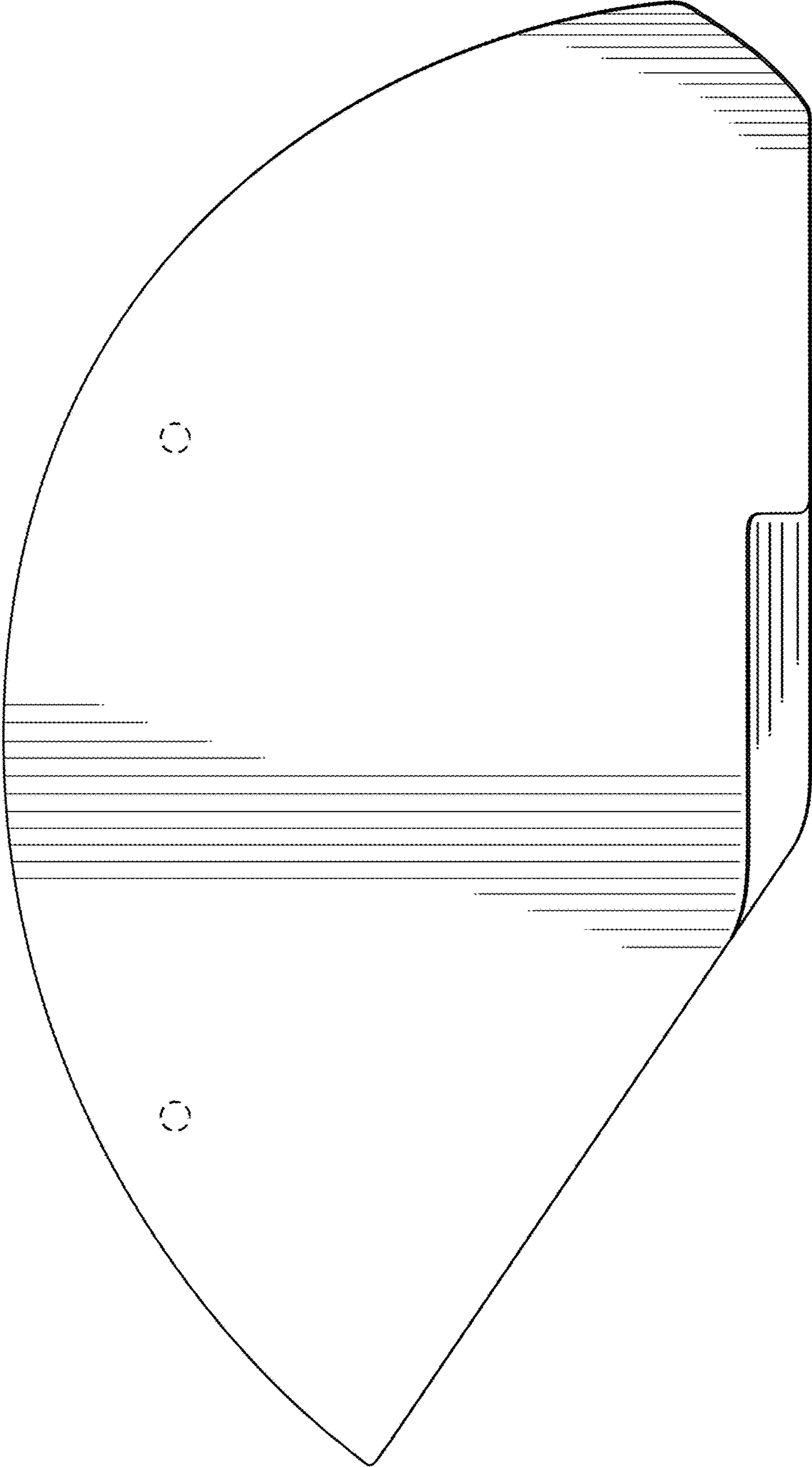
**Fig. 9**



**Fig. 10**



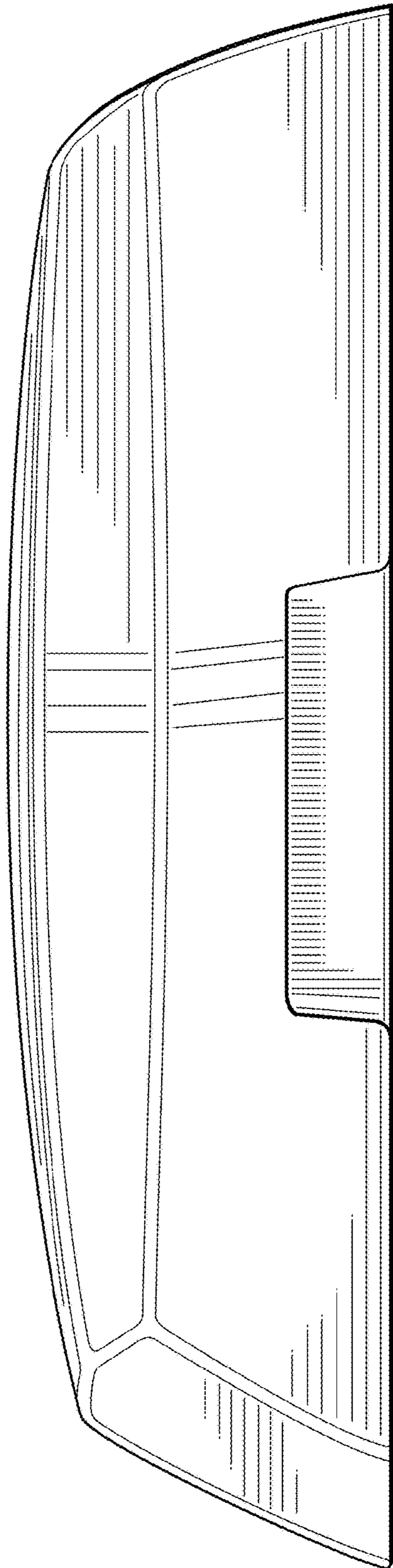
**Fig. 11**



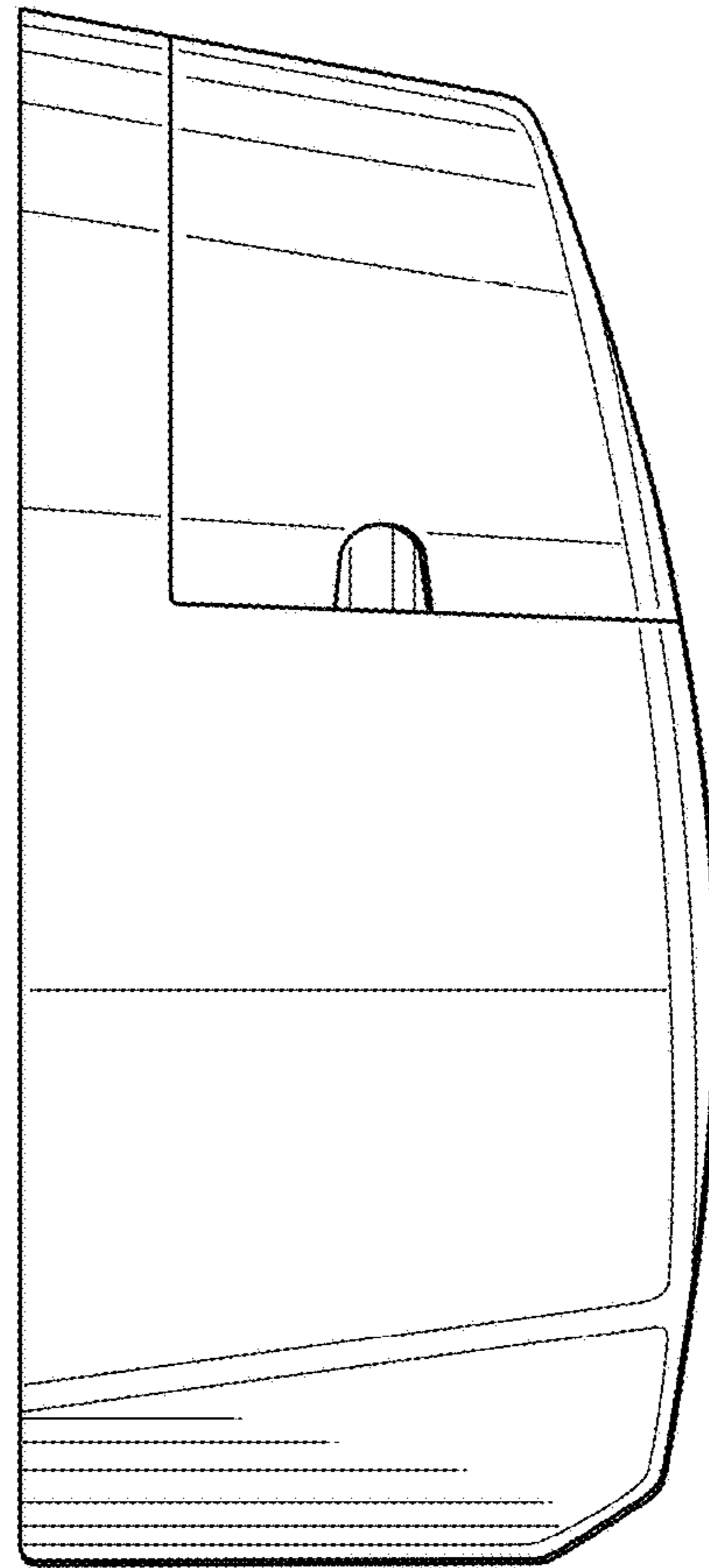
**Fig. 12**



**Fig. 13**



**Fig. 14**



**Fig. 15**

