



US00D829958S

(12) **United States Design Patent**  
**Brennenstuhl et al.**

(10) **Patent No.:** **US D829,958 S**

(45) **Date of Patent:** **\*\* Oct. 2, 2018**

(54) **LUMINAIRE**

(71) Applicant: **Nimbus Group GmbH**, Stuttgart (DE)

(72) Inventors: **Dietrich Brennenstuhl**, Stuttgart (DE);  
**Rupert Kopp**, Berlin (DE)

(73) Assignee: **Nimbus Group GmbH**, Stuttgart (DE)

(\*\*) Term: **15 Years**

(21) Appl. No.: **29/612,448**

(22) Filed: **Aug. 1, 2017**

(30) **Foreign Application Priority Data**

Feb. 1, 2017 (EM) ..... 003734367

(51) **LOC (11) Cl.** ..... **26-03**

(52) **U.S. Cl.**  
USPC ..... **D26/88**

(58) **Field of Classification Search**  
USPC ..... D26/72, 85, 88, 89, 120  
CPC ..... F21S 8/03; F21S 8/04; F21S 8/043; F21S  
8/046; F21S 8/068  
See application file for complete search history.

(56) **References Cited**

**U.S. PATENT DOCUMENTS**

|            |   |         |            |       |         |
|------------|---|---------|------------|-------|---------|
| D292,525 S | * | 10/1987 | Van Deelen | ..... | D26/85  |
| D613,449 S | * | 4/2010  | Ngai       | ..... | D26/120 |
| D623,794 S | * | 9/2010  | Ngai       | ..... | D26/120 |
| D623,795 S | * | 9/2010  | Ngai       | ..... | D26/120 |
| D646,423 S | * | 10/2011 | Chiu       | ..... | D26/85  |
| D769,507 S | * | 10/2016 | Raasch     | ..... | D26/88  |
| D780,979 S | * | 3/2017  | Urquiola   | ..... | D26/88  |

|            |   |         |          |       |        |
|------------|---|---------|----------|-------|--------|
| D781,484 S | * | 3/2017  | Urquiola | ..... | D26/85 |
| D791,386 S | * | 7/2017  | Arndt    | ..... | D26/88 |
| D805,239 S | * | 12/2017 | Arndt    | ..... | D26/88 |
| D807,561 S | * | 1/2018  | Ng       | ..... | D26/88 |

**OTHER PUBLICATIONS**

“Chords” pendant light by Teruhiro Yanagihara. Published Apr. 2010 at designboom.com. (Year: 2010).\*

“North” pendant light by Eva Maguerre and Marcel Besau Apr. 2014, from stillfried.com. (Year: 2014).\*

\* cited by examiner

*Primary Examiner* — Clare E Heflin

(74) *Attorney, Agent, or Firm* — Reising Ethington, P.C.

(57) **CLAIM**

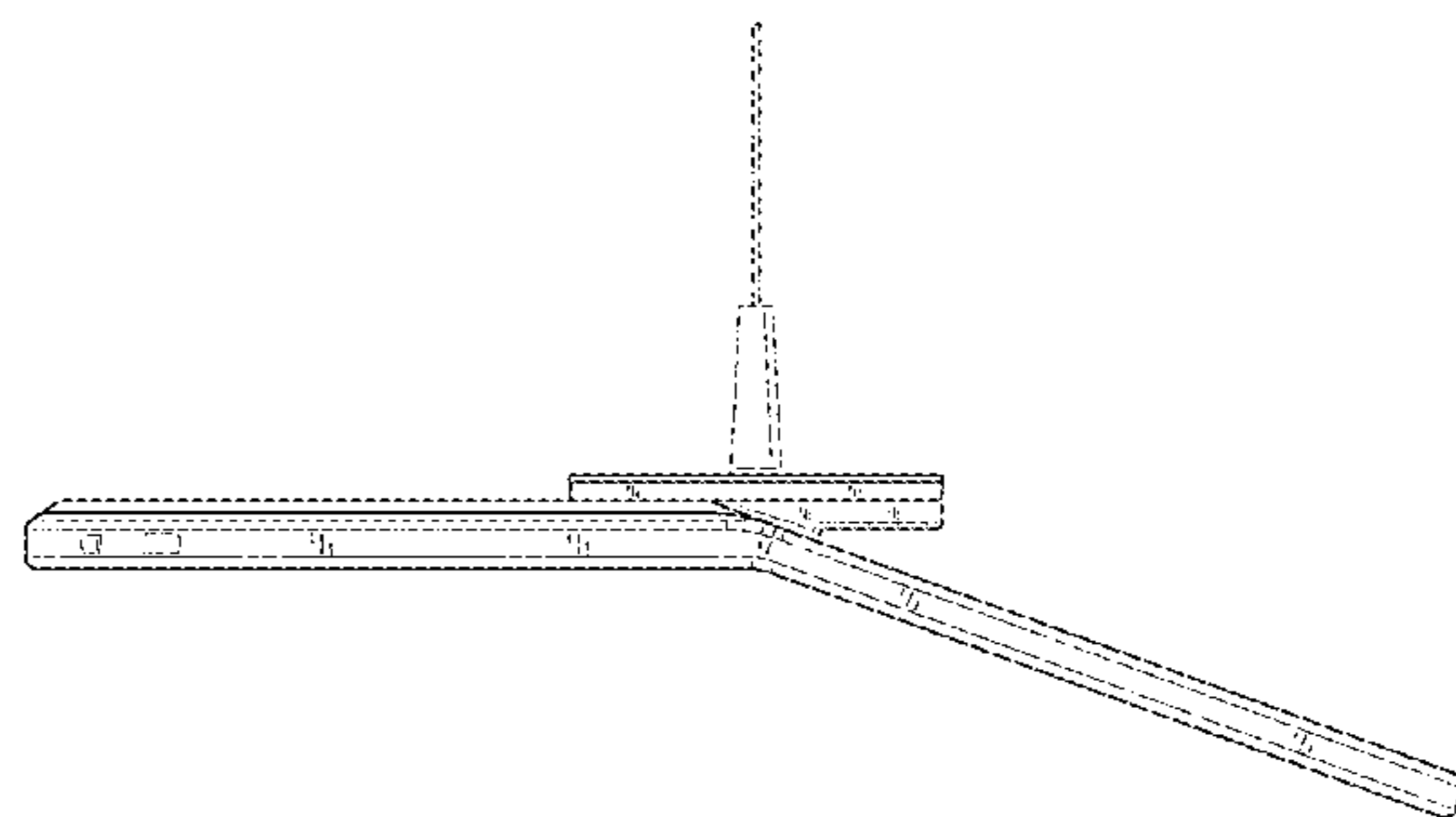
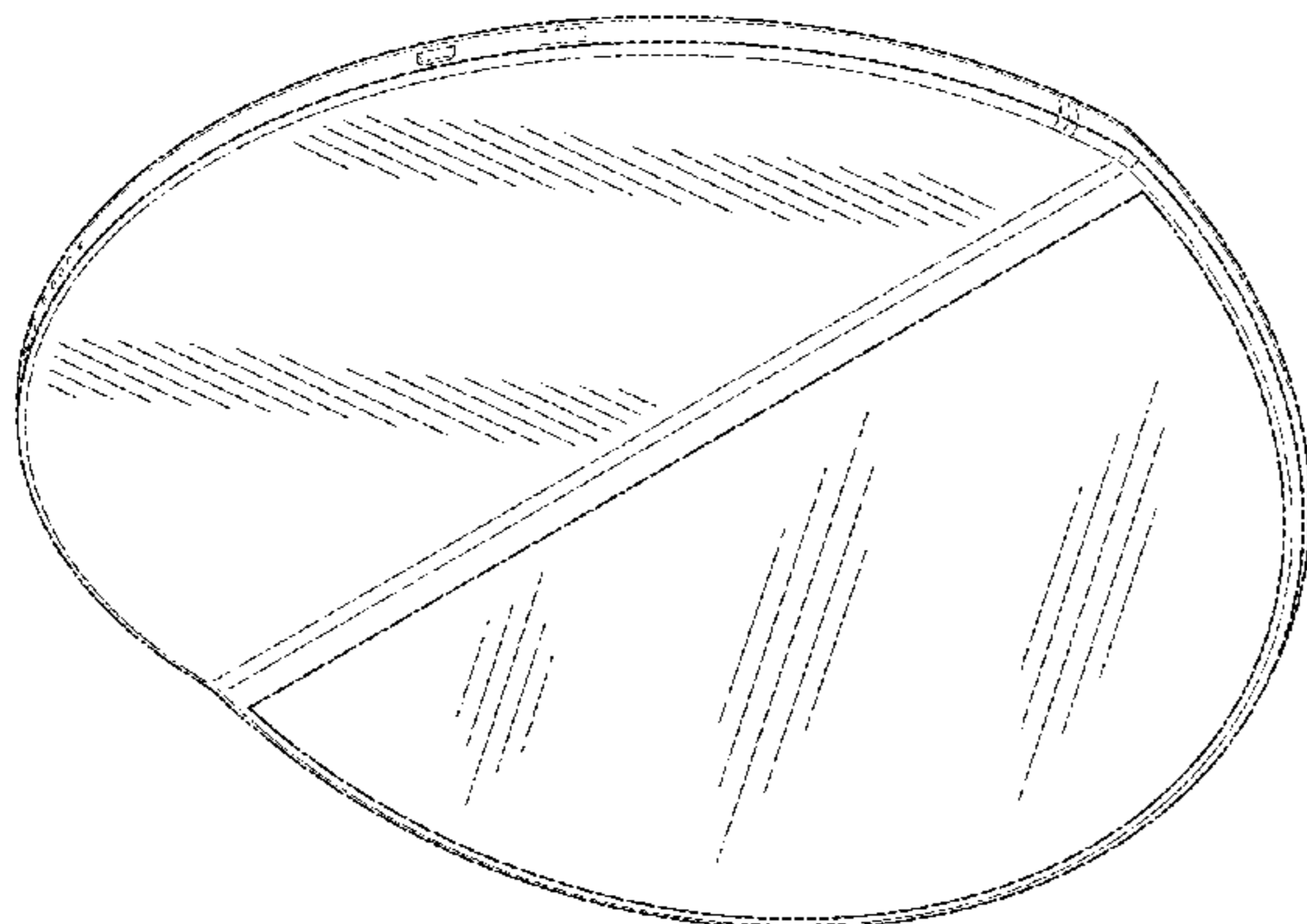
The ornamental design for a luminaire, as shown and described.

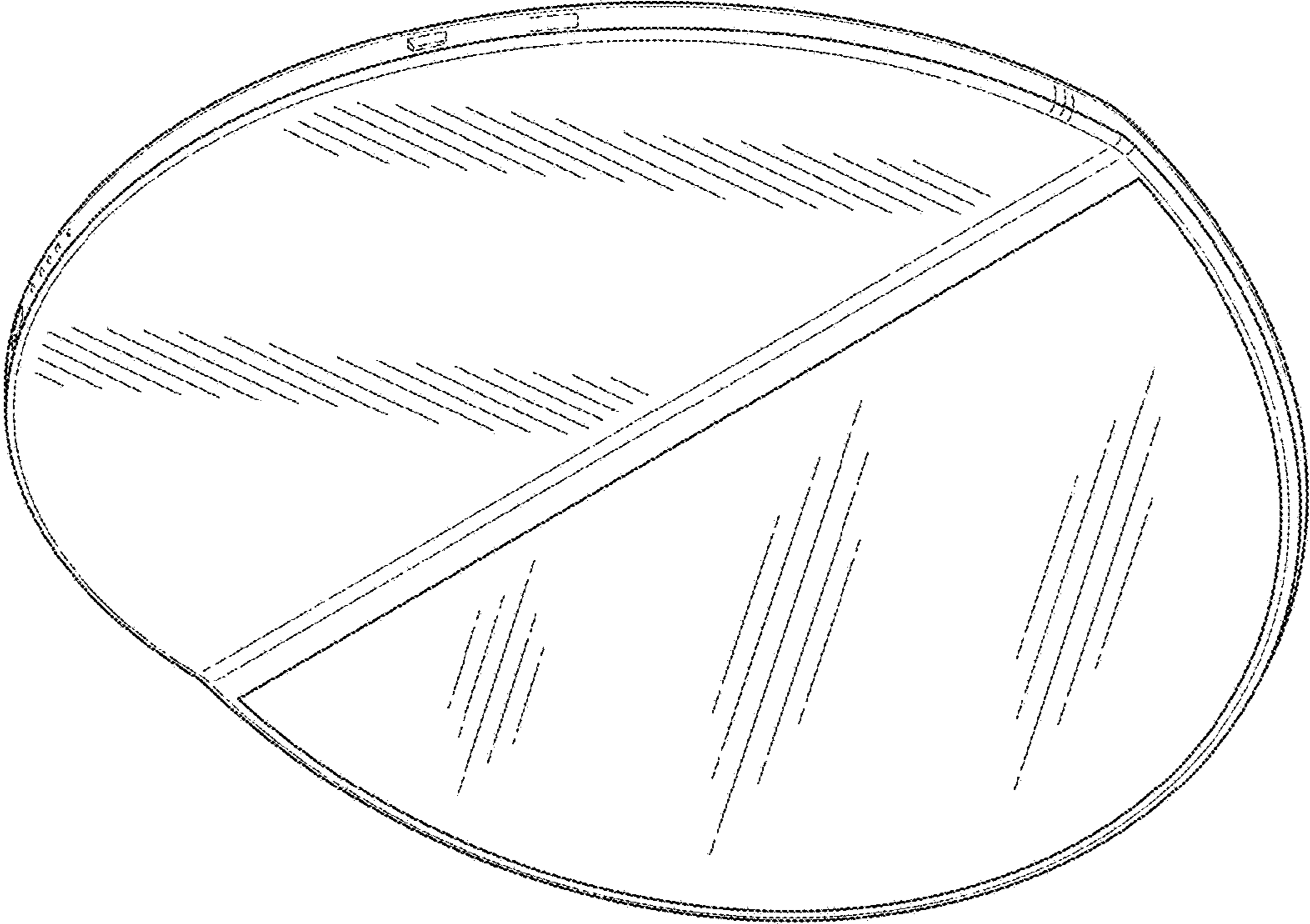
**DESCRIPTION**

FIG. 1 is a perspective view of the luminaire;  
FIG. 2 is a side view thereof;  
FIG. 3 is a bottom view thereof;  
FIG. 4 is another side view thereof;  
FIG. 5 is a front view thereof;  
FIG. 6 is a rear view thereof; and,  
FIG. 7 is a top view thereof.

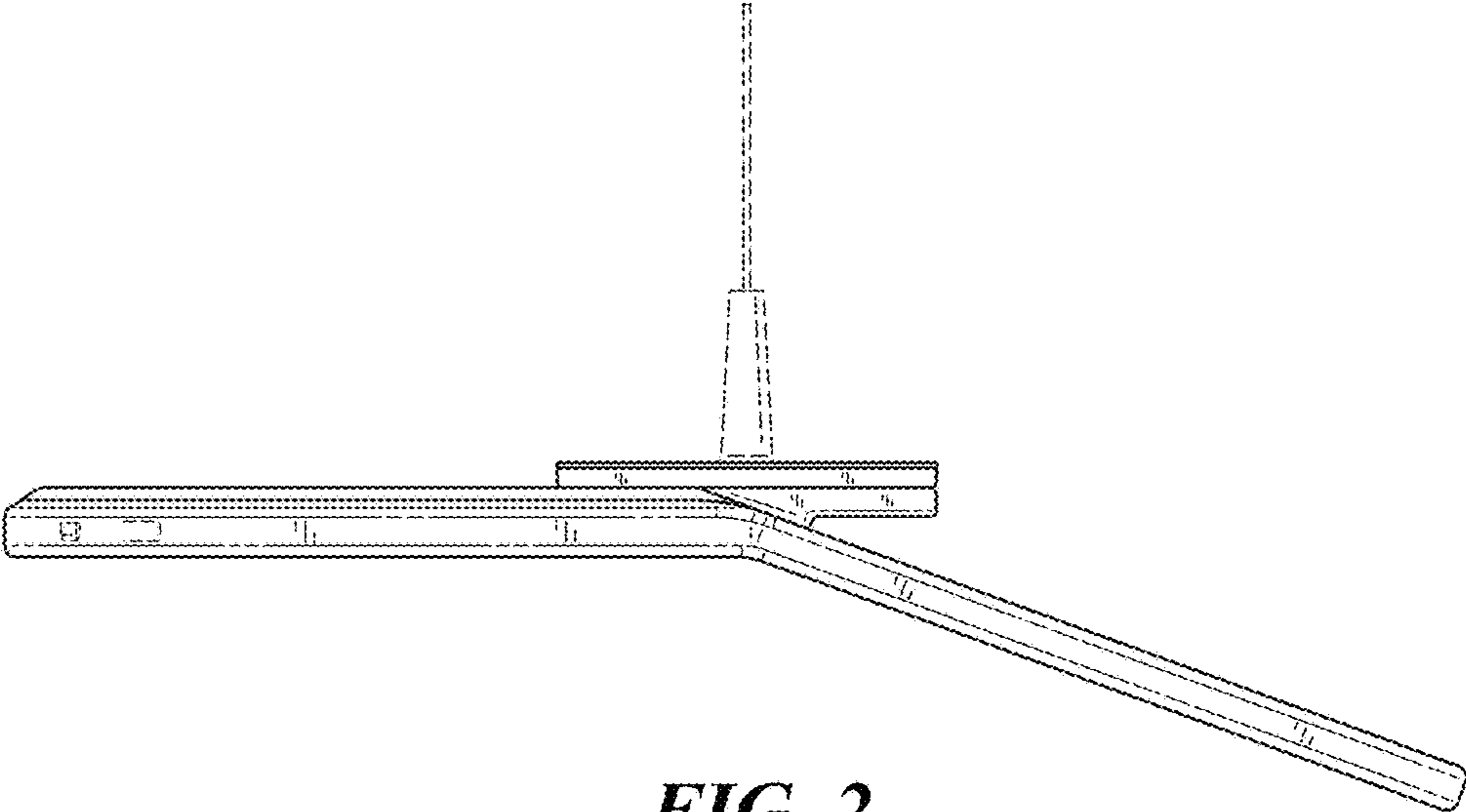
In the drawings, the portions shown by broken lines form no part of the claimed design. Further, in the drawings, clusters of oblique lines are used to show surfaces of the luminaire that are transparent and translucent, as demonstrated, for example, by the half-circular surfaces in FIGS. 5 and 6.

**1 Claim, 4 Drawing Sheets**

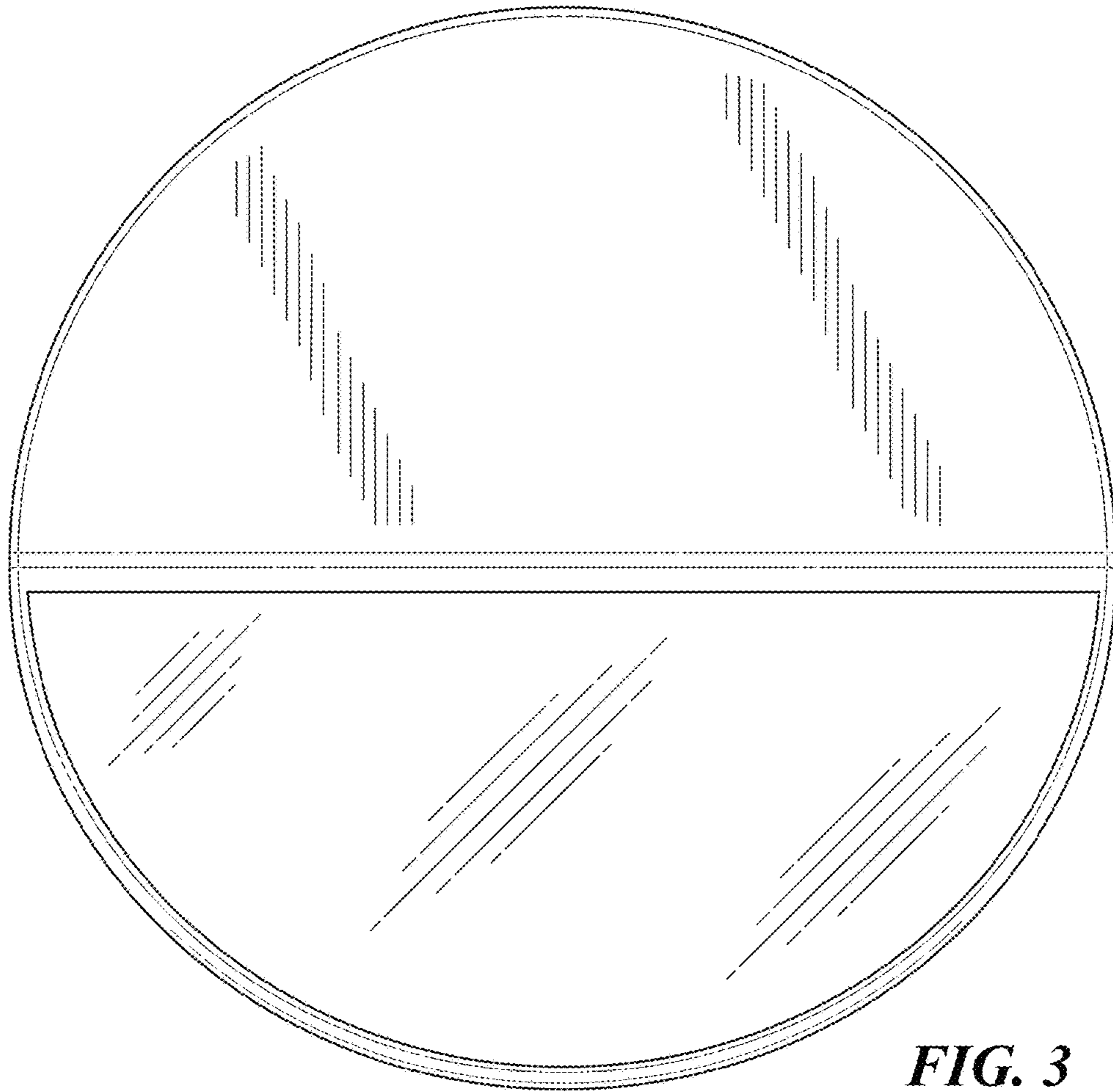




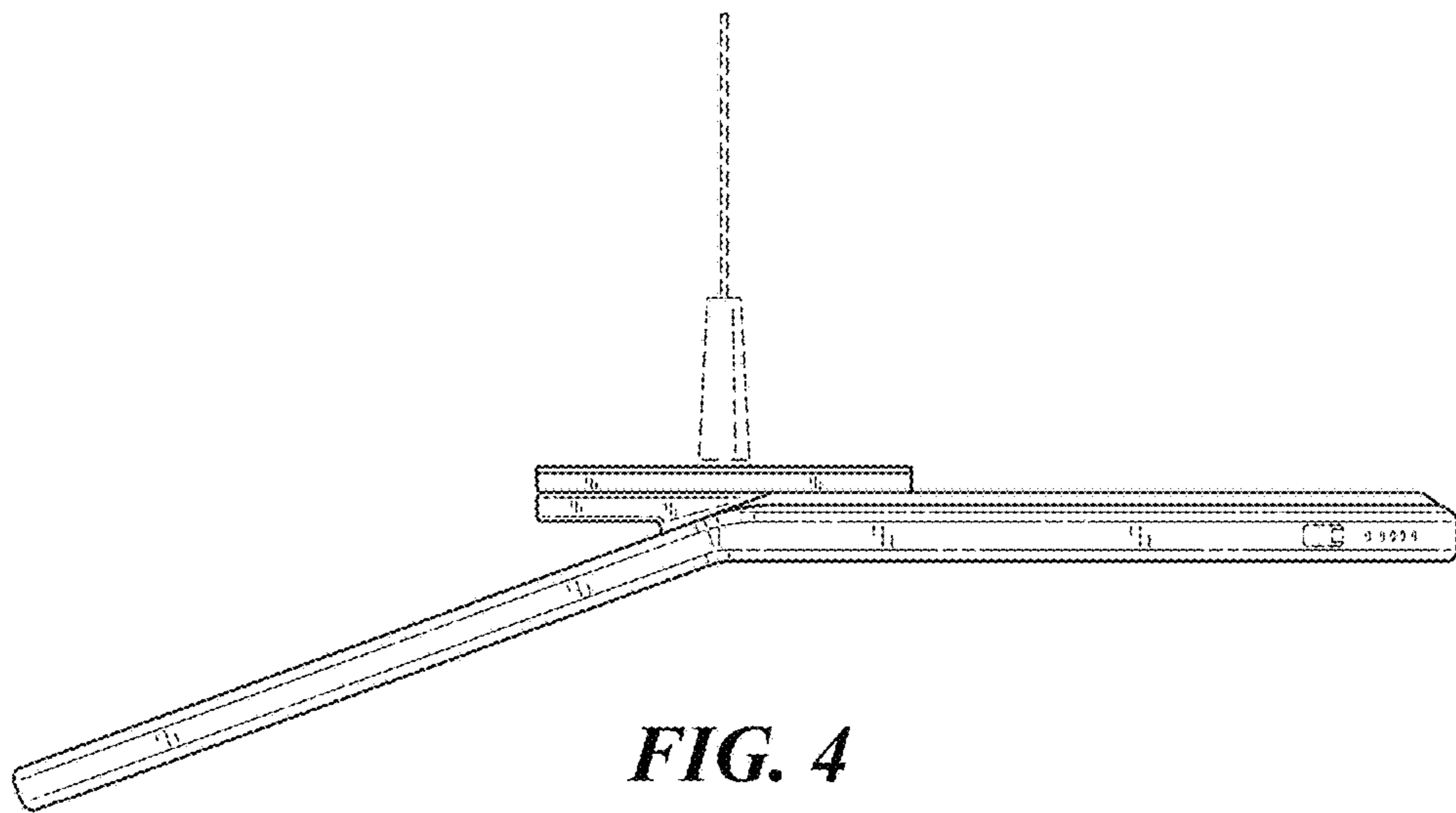
**FIG. 1**



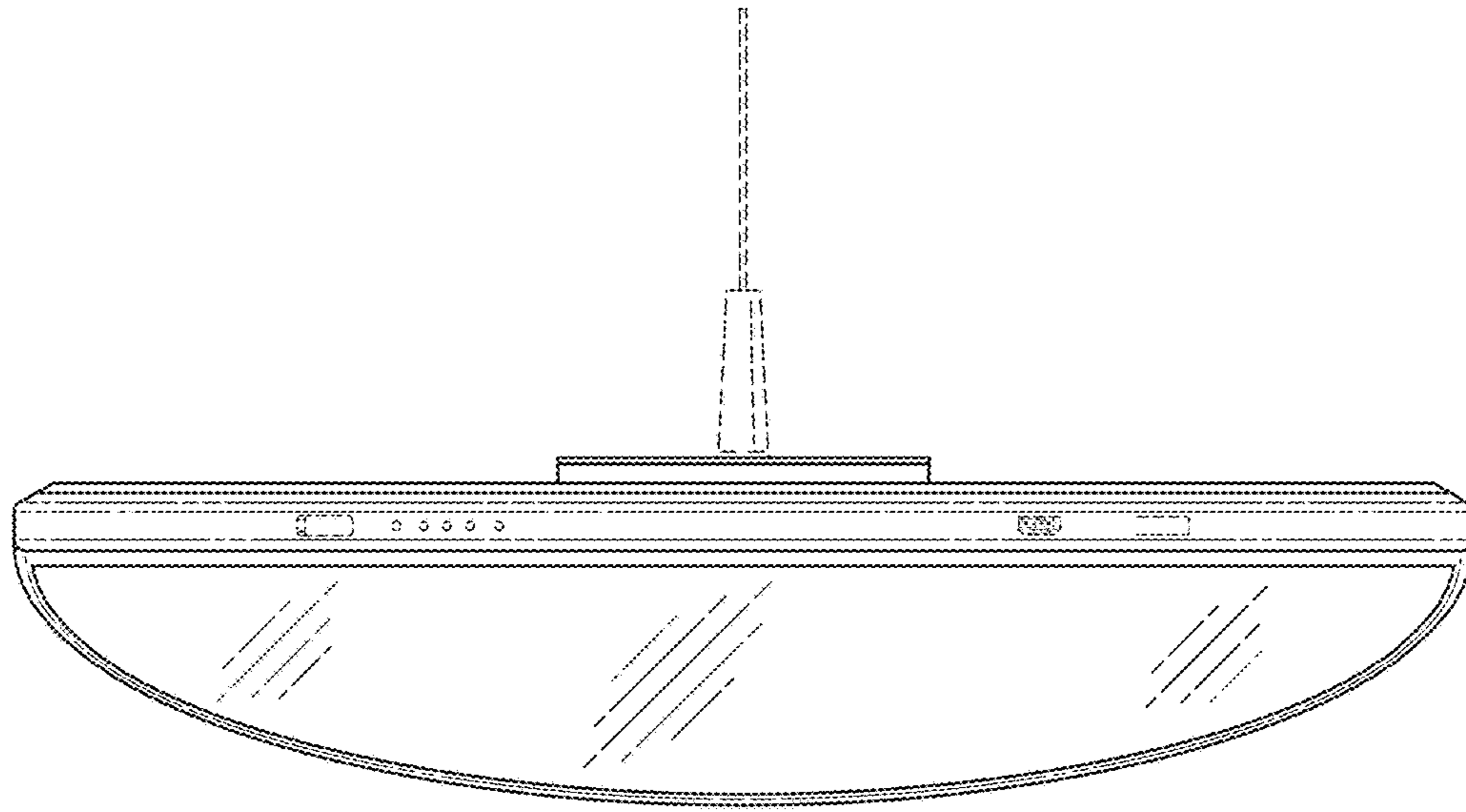
**FIG. 2**



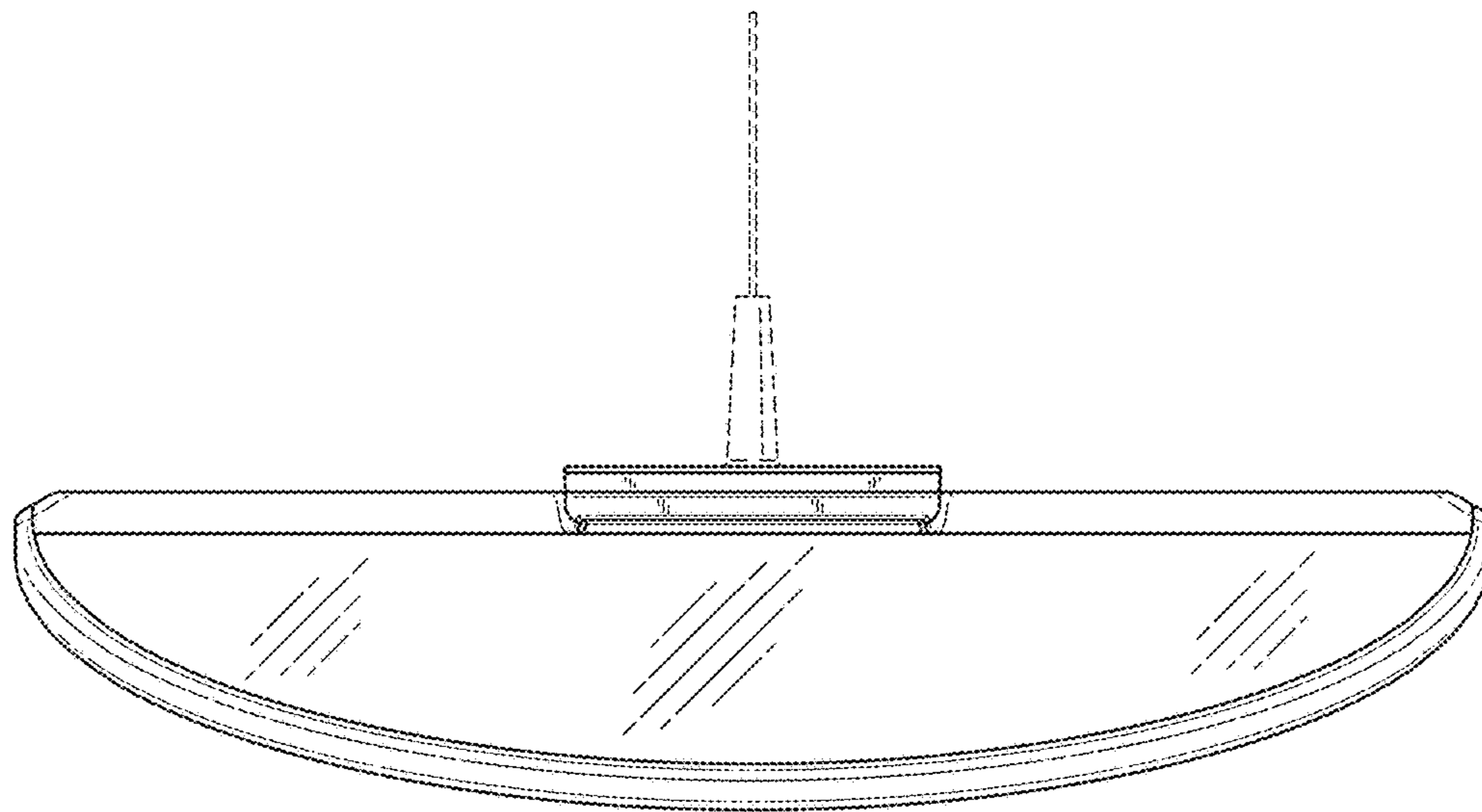
**FIG. 3**



**FIG. 4**

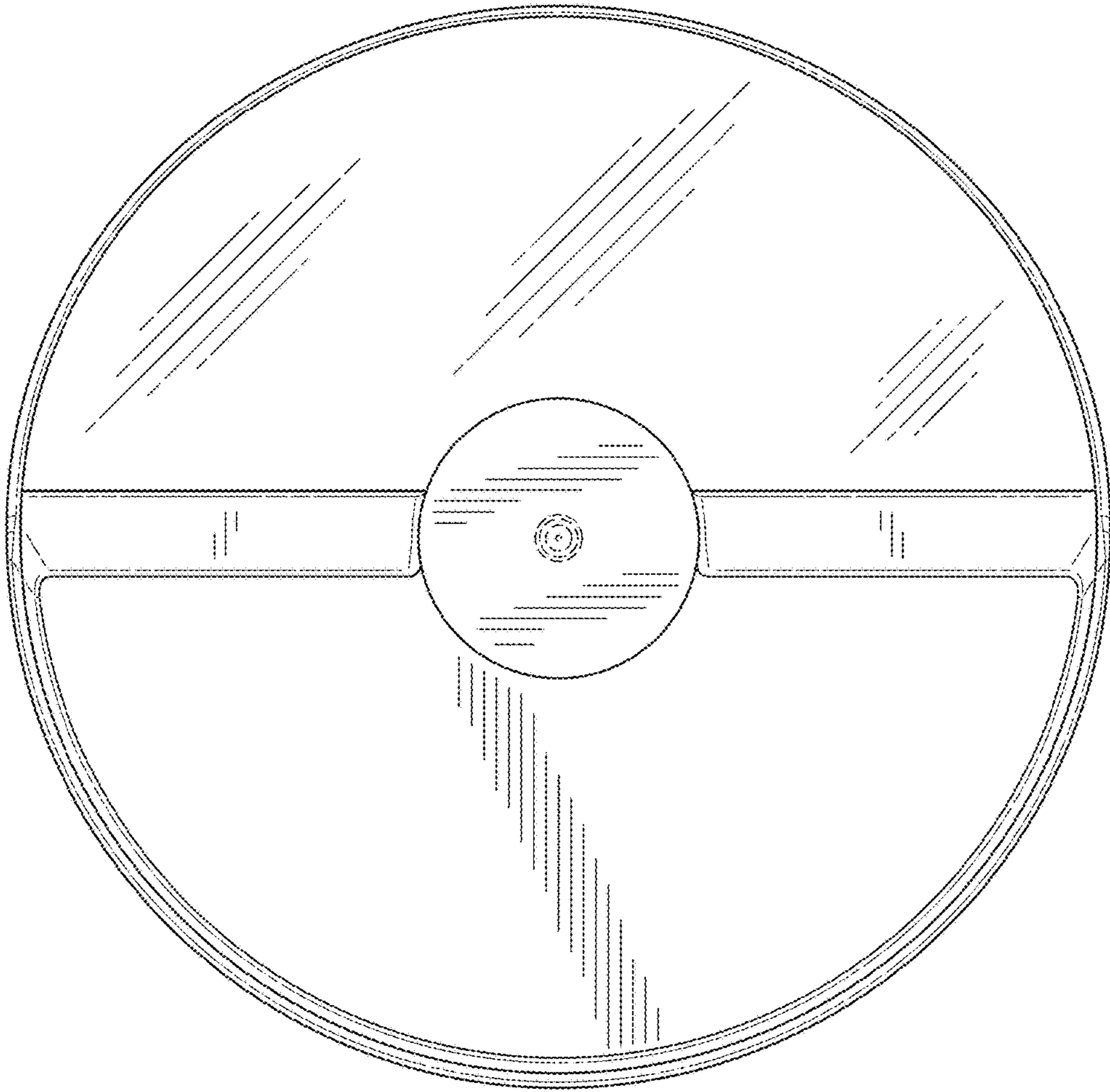


**FIG. 5**



**FIG. 6**





**FIG. 7**