



US00D829635S

(12) **United States Design Patent** (10) **Patent No.:** **US D829,635 S**  
**Verachttert et al.** (45) **Date of Patent:** **\*\* Oct. 2, 2018**

(54) **VEHICLE ROOF**  
(71) Applicants: **Robin Tristan Serge Verachttert**,  
Chardonne (CH); **Dennis Lloyd**  
**Shaffer, Jr.**, Henderson, NV (US)  
(72) Inventors: **Robin Tristan Serge Verachttert**,  
Chardonne (CH); **Dennis Lloyd**  
**Shaffer, Jr.**, Henderson, NV (US)  
(\*\*) Term: **15 Years**  
(21) Appl. No.: **29/627,187**  
(22) Filed: **Nov. 22, 2017**

2015/0336449 A1\* 11/2015 Kamioku ..... B60J 7/057  
296/216.04  
2016/0200183 A1\* 7/2016 Holzel ..... B60J 7/0435  
296/216.05  
2016/0214466 A1\* 7/2016 Kolger ..... B60J 7/0015  
2017/0113523 A1\* 4/2017 Holzel ..... B60J 7/0435

\* cited by examiner

*Primary Examiner* — Katrina A Betton  
(74) *Attorney, Agent, or Firm* — Quickpatents, LLC;  
Kevin Prince

(57) **CLAIM**

We claim the ornamental design for a vehicle roof, as shown and described.

**Related U.S. Application Data**

(62) Division of application No. 29/600,191, filed on Apr. 10, 2017, now Pat. No. Des. 808,886.  
(51) **LOC (11) Cl.** ..... **12-16**  
(52) **U.S. Cl.**  
USPC ..... **D12/404**  
(58) **Field of Classification Search**  
USPC ..... D12/401–405  
CPC ..... A47D 15/00; A47C 7/66; A47C 31/00;  
A47G 9/068  
See application file for complete search history.

**DESCRIPTION**

FIG. 1 is a top perspective view of a vehicle roof, showing a first embodiment of our new design;  
FIG. 2 is a bottom perspective view of FIG. 1;  
FIG. 3 is a top plan view of FIG. 1;  
FIG. 4 is a bottom plan view of FIG. 1;  
FIG. 5 is a front elevational view of FIG. 1, the rear elevational view being a mirror image thereof;  
FIG. 6 is a left-side elevational view of FIG. 1, the right-side elevational view being a mirror image thereof;  
FIG. 7 is a top perspective view of a second embodiment thereof;  
FIG. 8 is a bottom perspective view of FIG. 7;  
FIG. 9 is a top plan view of FIG. 7;  
FIG. 10 is a bottom plan view of FIG. 7;  
FIG. 11 is a front elevational view of FIG. 7, the rear elevational view being a mirror image thereof; and,  
FIG. 12 is a left-side elevational view of FIG. 7, the right-side elevational view being a mirror image thereof.  
The broken lines showing a vehicle and corner portions of the windows in the figures depict environmental matter and form no part of the claimed design. The remaining dot-dash broken lines represent a boundary of the claimed design.

(56) **References Cited**

**U.S. PATENT DOCUMENTS**

D438,840 S \* 3/2001 Dowdey ..... D12/404  
D483,317 S \* 12/2003 Dowdey ..... D12/404  
D625,680 S \* 10/2010 de Waal ..... D12/404  
9,150,159 B1 \* 10/2015 Meszaros ..... B60R 9/045  
D748,564 S \* 2/2016 Frascella ..... D12/404  
2009/0066110 A1 \* 3/2009 Beierl ..... B60J 10/82  
296/107.01  
2012/0126583 A1 \* 5/2012 Brown ..... B60R 13/0231  
296/210  
2013/0257108 A1 \* 10/2013 Sugimoto ..... B60J 7/0007  
296/214

**1 Claim, 8 Drawing Sheets**

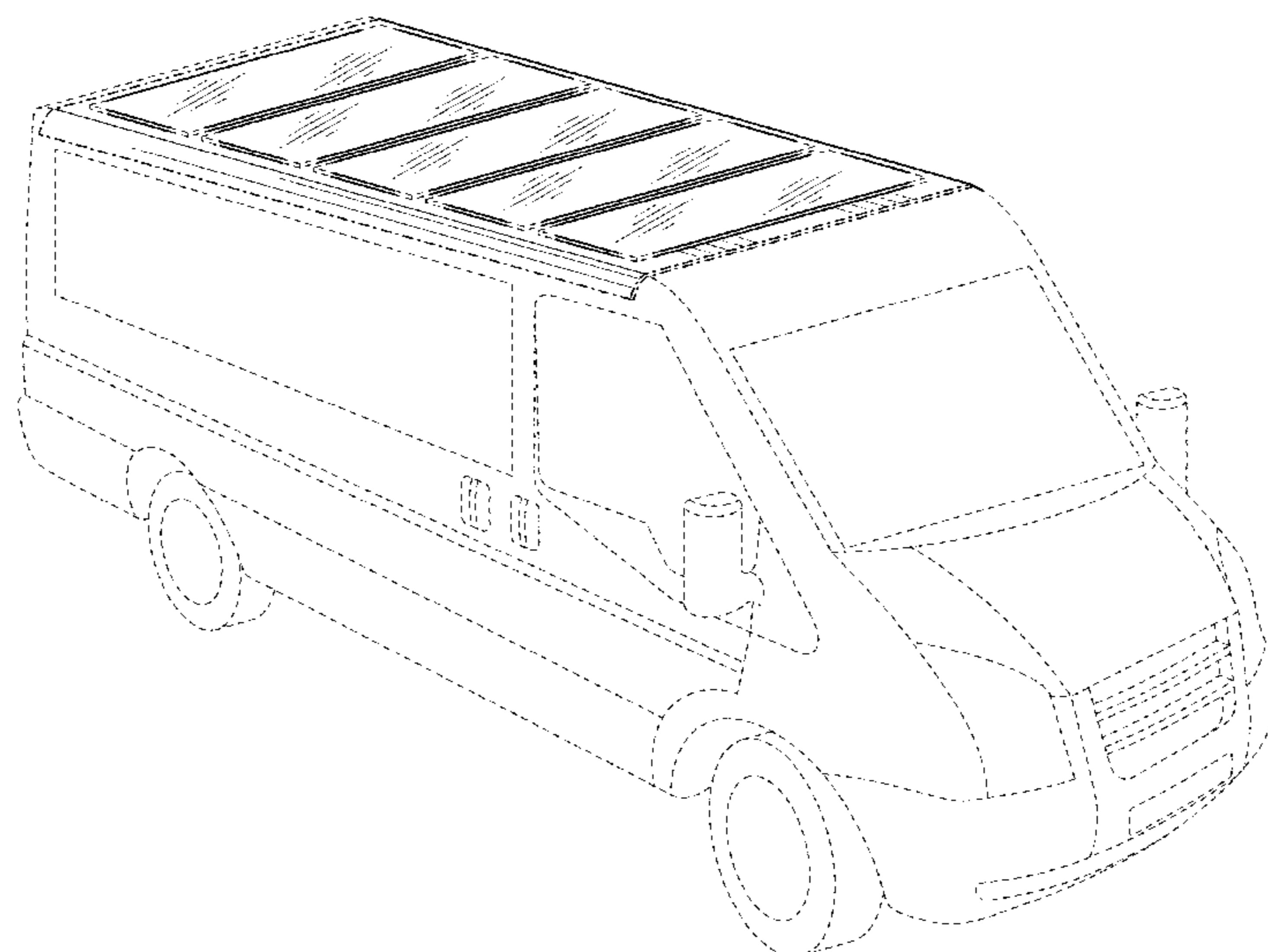

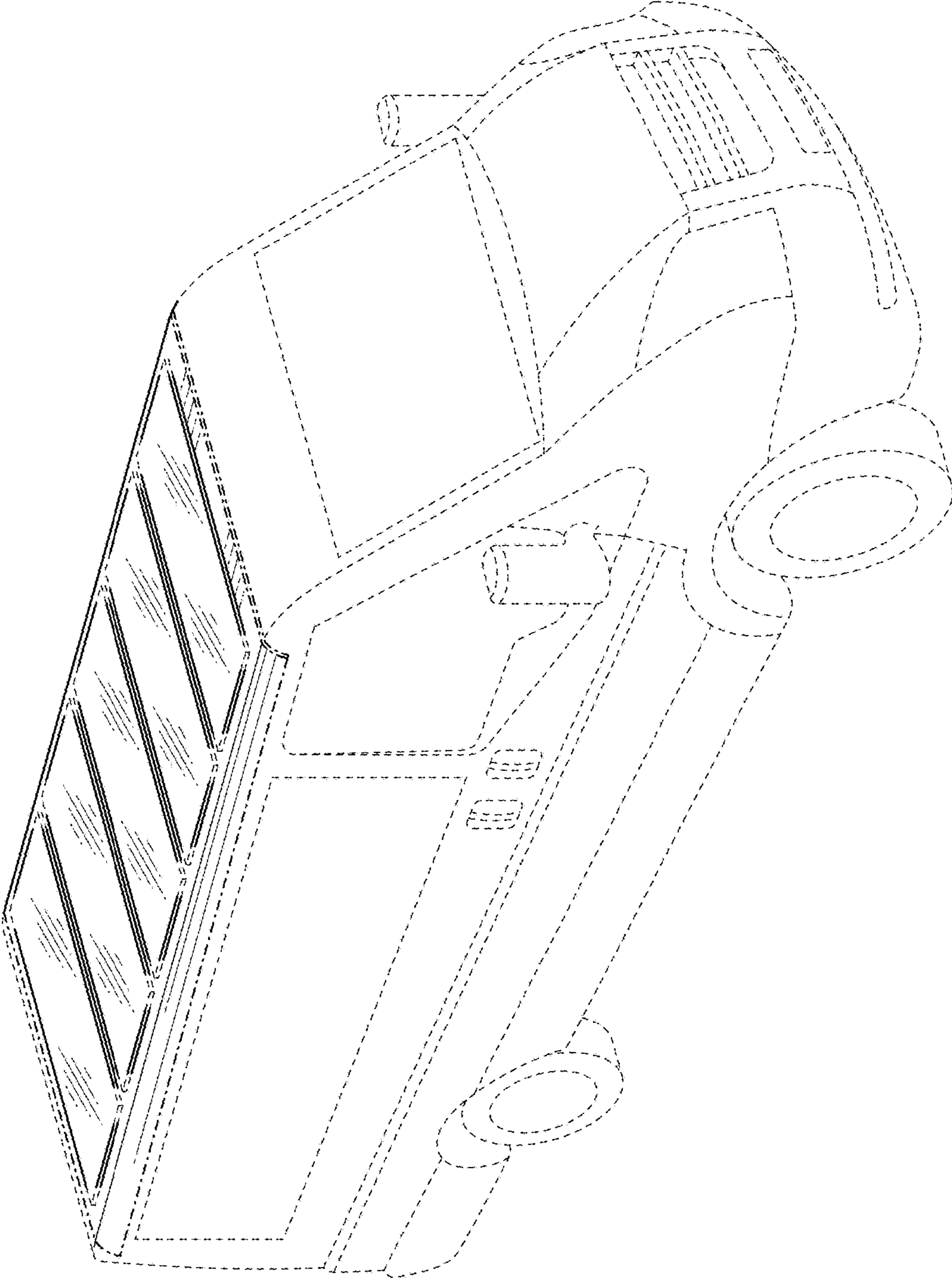

FIG. 1

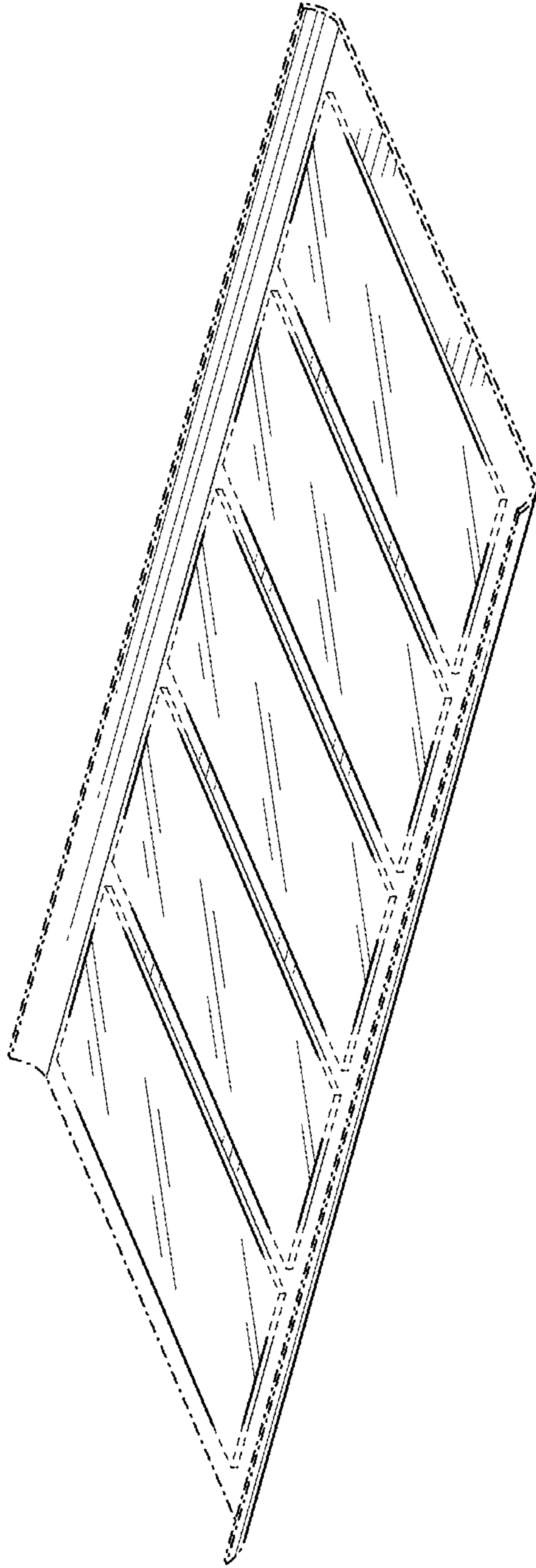

FIG. 2

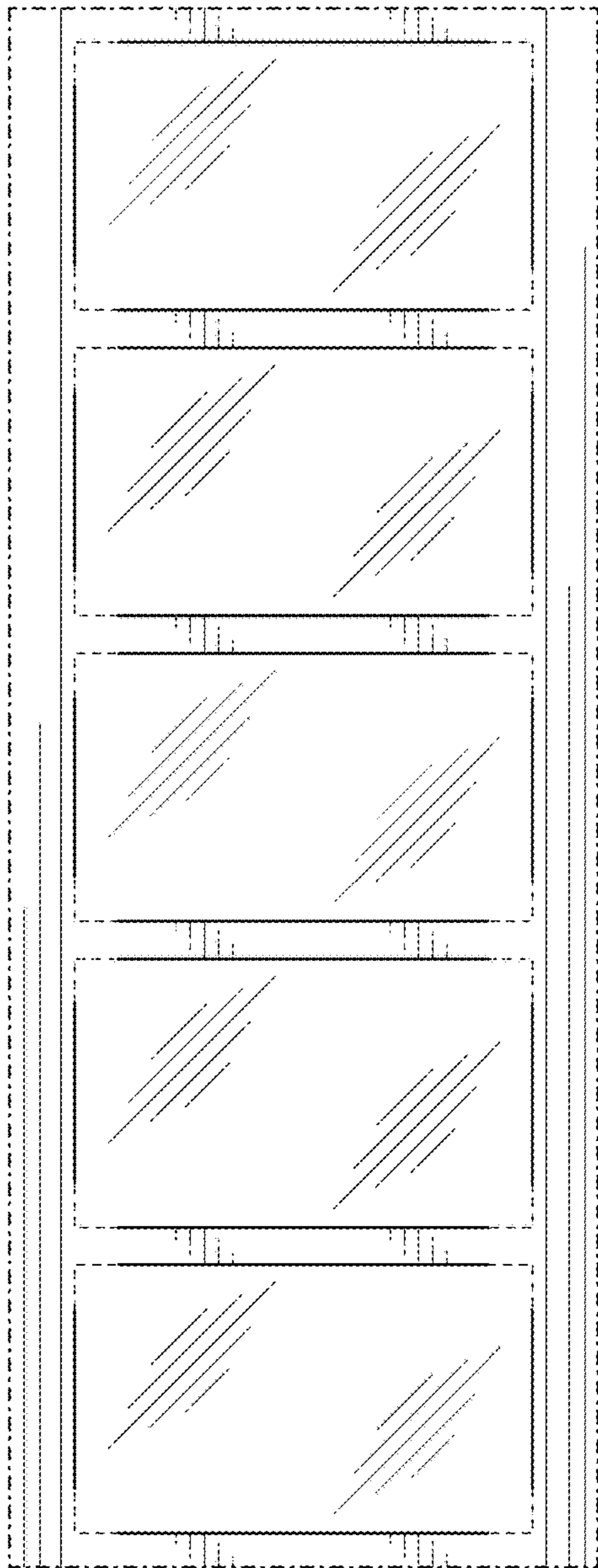

FIG. 3

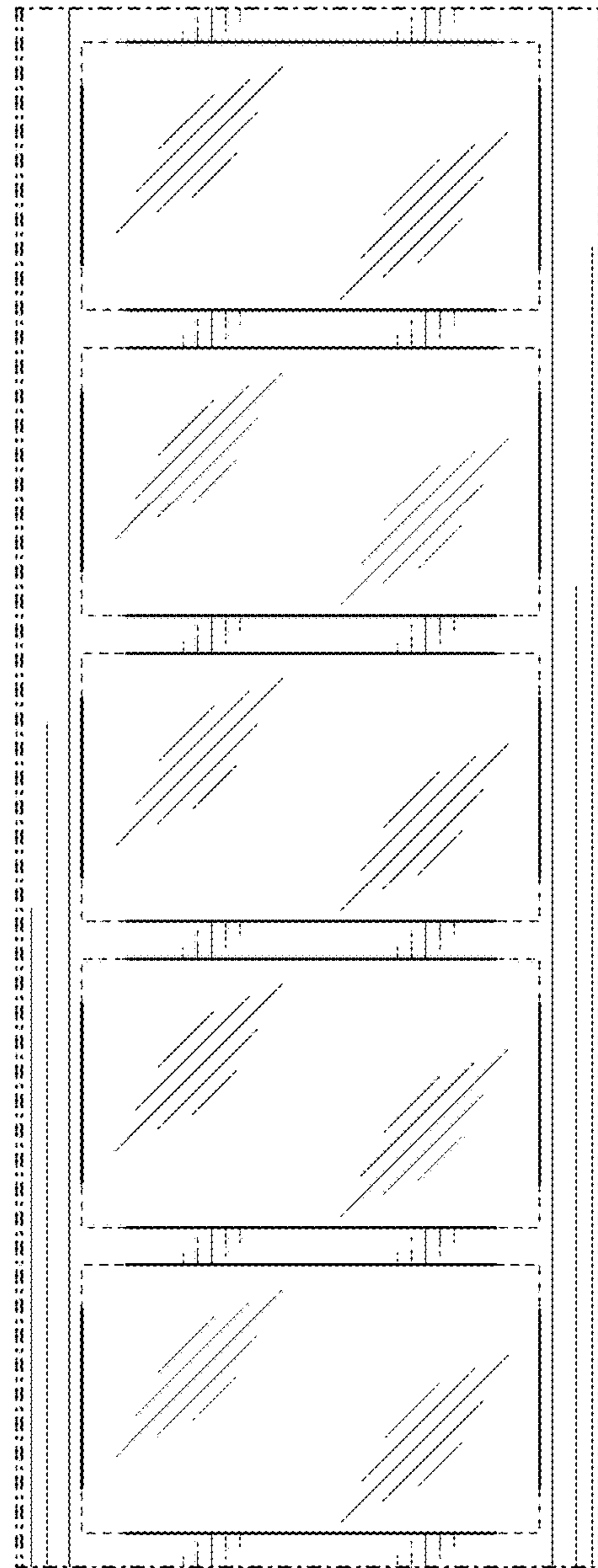

FIG. 4



FIG. 5



FIG. 6

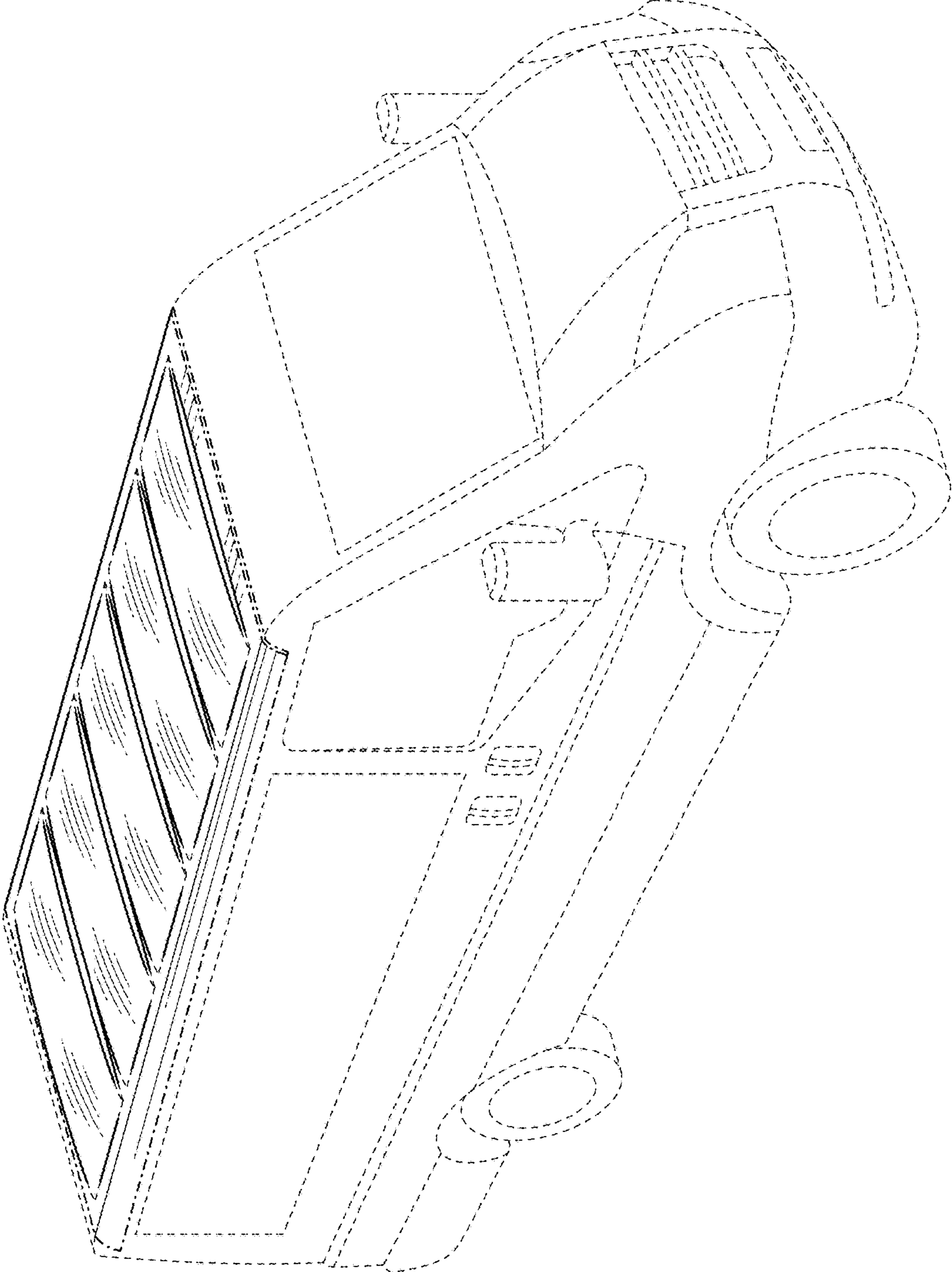

FIG. 7

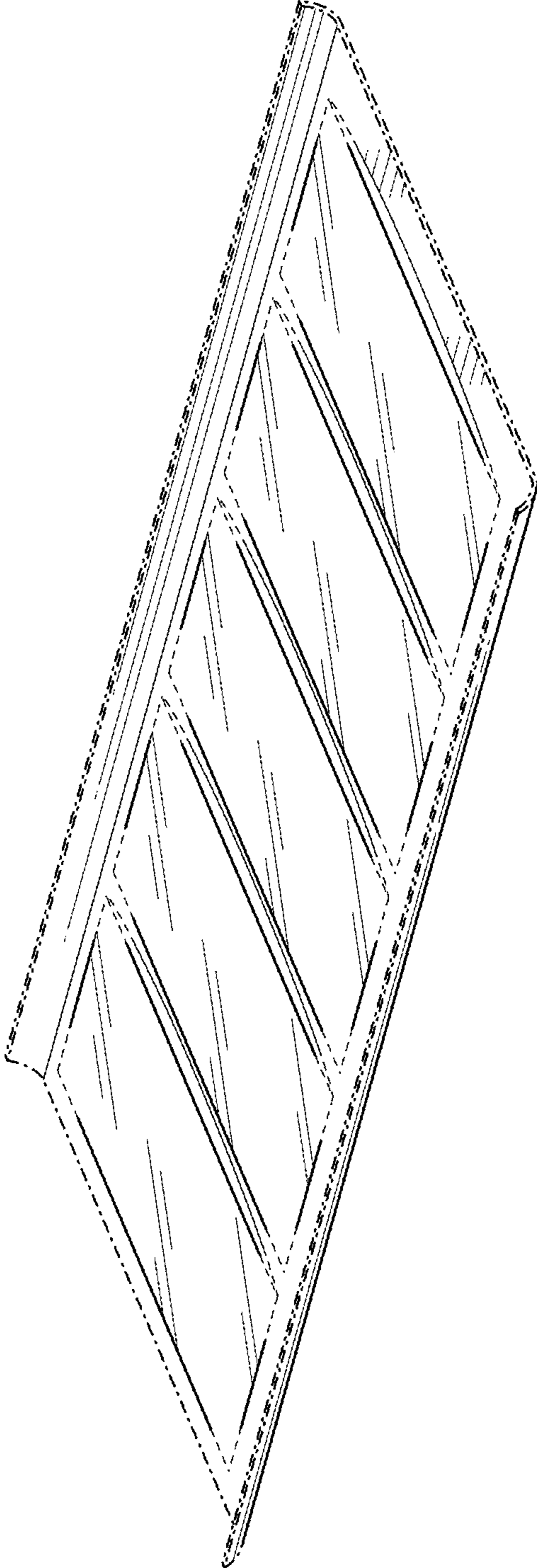

FIG. 8

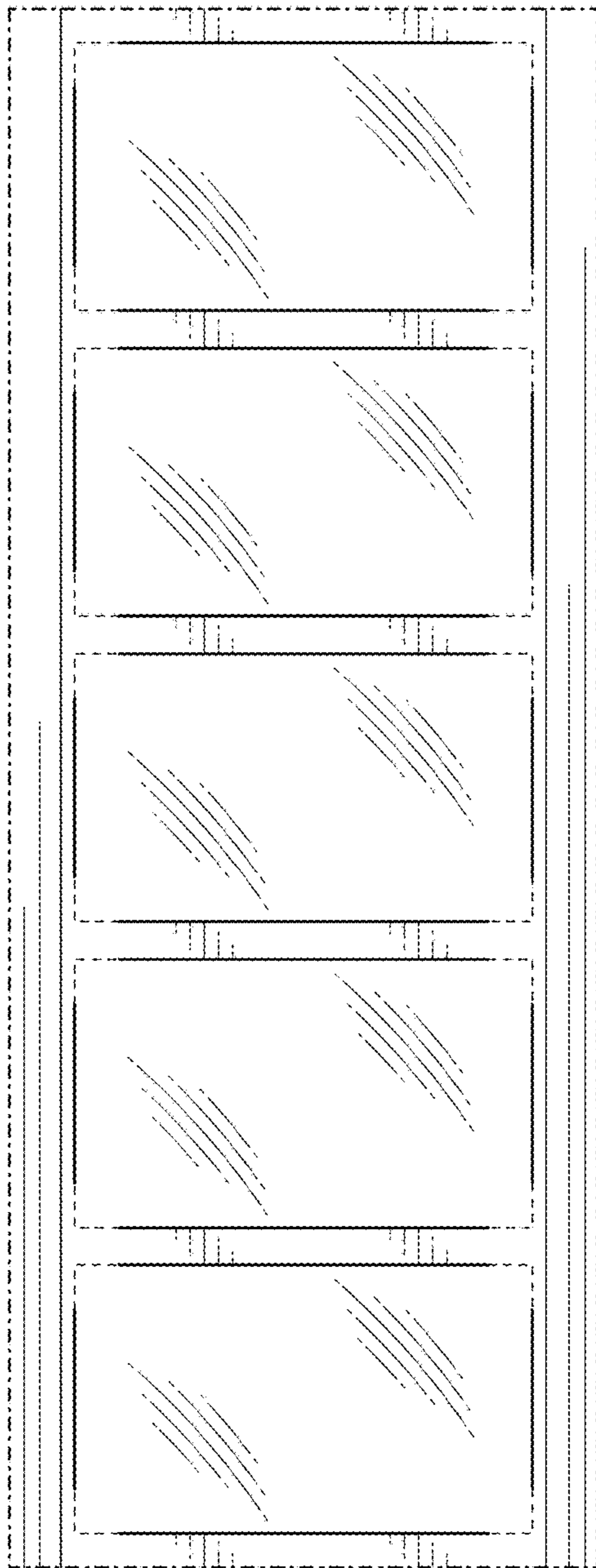

FIG. 9

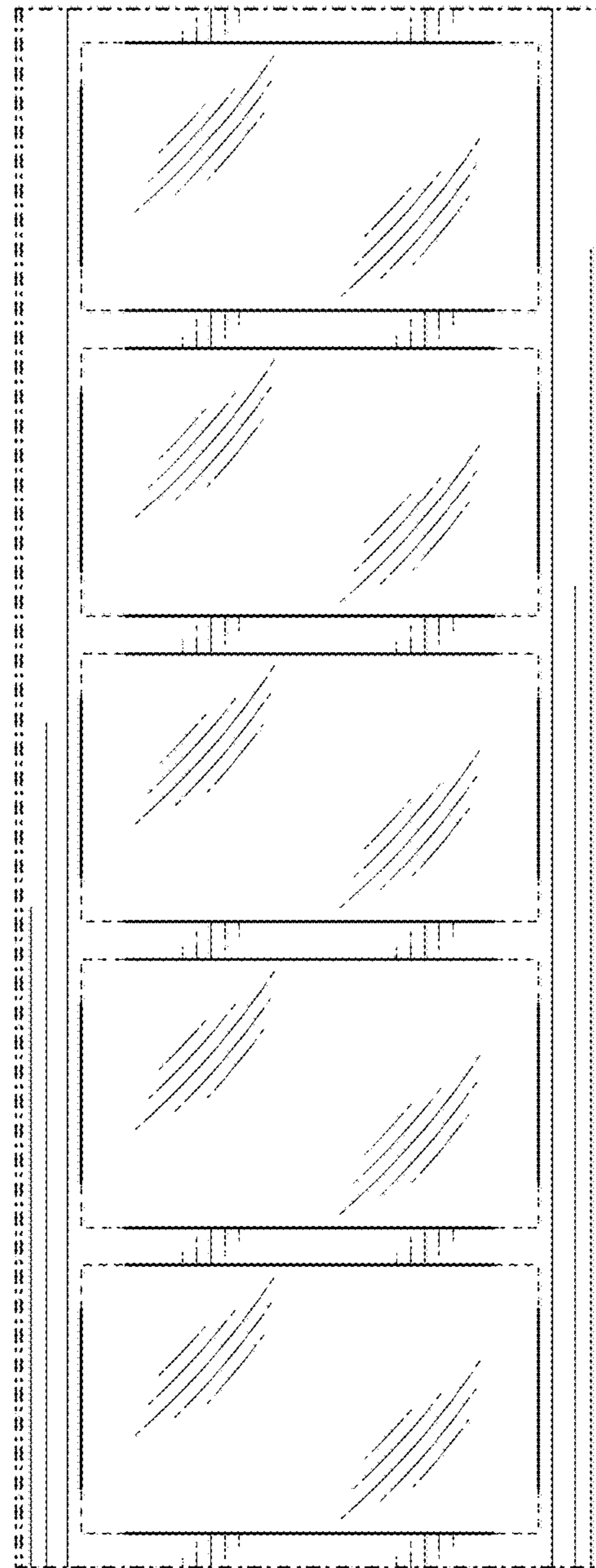

FIG. 10





FIG. 11



FIG. 12