



US00D829320S

(12) **United States Design Patent** (10) **Patent No.:** **US D829,320 S**  
**Terai et al.** (45) **Date of Patent:** **\*\* Sep. 25, 2018**

(54) **AIR OUTLET OF AIR CONDITIONER FOR VEHICLE**

(71) Applicant: **TOYODA GOSEI CO., LTD.**,  
Kiyosu-shi, Aichi-ken (JP)

(72) Inventors: **Nobuhiro Terai**, Kiyosu (JP); **Kenji Asano**, Nagoya (JP)

(73) Assignee: **TOYODA GOSEI CO., LTD.**,  
Aichi-pref. (JP)

(\*\*) Term: **15 Years**

(21) Appl. No.: **29/601,335**

(22) Filed: **Apr. 21, 2017**

(30) **Foreign Application Priority Data**

Dec. 27, 2016 (JP) ..... 2016-028282  
Dec. 27, 2016 (JP) ..... 2016-028283

(51) **LOC (11) Cl.** ..... **23-04**

(52) **U.S. Cl.**  
USPC ..... **D23/387**

(58) **Field of Classification Search**  
USPC ..... D23/386, 388, 392, 393, 397, 399, 400,  
D23/406, 411, 412, 354; D8/321  
(Continued)

(56) **References Cited**

**U.S. PATENT DOCUMENTS**

1,817,836 A \* 8/1931 Petrelli ..... F24F 13/15  
454/325  
2,154,731 A \* 4/1939 Crowley ..... B60S 1/54  
239/284.1

(Continued)

**OTHER PUBLICATIONS**

Fiabilité Renault Problème de compresseur de climatisation, image post date Sep. 29, 2015, site visited May 25, 2018, (online),

<<http://www.largus.fr/actualite-automobile/fiabilite-renault-probleme-de-compresseur-de-climatisation-6597398.html>>.\*

(Continued)

*Primary Examiner* — Kevin K Rudzinski

*Assistant Examiner* — Sean D Lough

(74) *Attorney, Agent, or Firm* — Posz Law Group, PLC

(57) **CLAIM**

The ornamental design for an air outlet of air conditioner for vehicle, as shown and described.

**DESCRIPTION**

FIG. 1 is a perspective view of a first embodiment of an air outlet of air conditioner for vehicle showing our new design; FIG. 2 is a front elevation view thereof; FIG. 3 is a rear elevation view thereof; FIG. 4 is a left side elevation view thereof; FIG. 5 is a right side elevation view thereof; FIG. 6 is a top plan view thereof; FIG. 7 is a bottom plan view thereof; FIG. 8 is a perspective view thereof depicted in a secondary position of use; FIG. 9 is a front elevation view thereof depicted in the secondary position of use; FIG. 10 is a rear elevation view thereof depicted in the secondary position of use; FIG. 11 is a perspective view of a second embodiment of an air outlet of air conditioner for vehicle showing our new design; FIG. 12 is a front elevation view thereof; FIG. 13 is a rear elevation view thereof; FIG. 14 is a left side elevation view thereof; FIG. 15 is a right side elevation view thereof; FIG. 16 is a top plan view thereof; FIG. 17 is a bottom plan view thereof; FIG. 18 is a perspective view thereof depicted in a secondary position of use; FIG. 19 is a front elevation view thereof depicted in the secondary position of use; and, FIG. 20 is a rear elevation view thereof depicted in the secondary position of use.

(Continued)

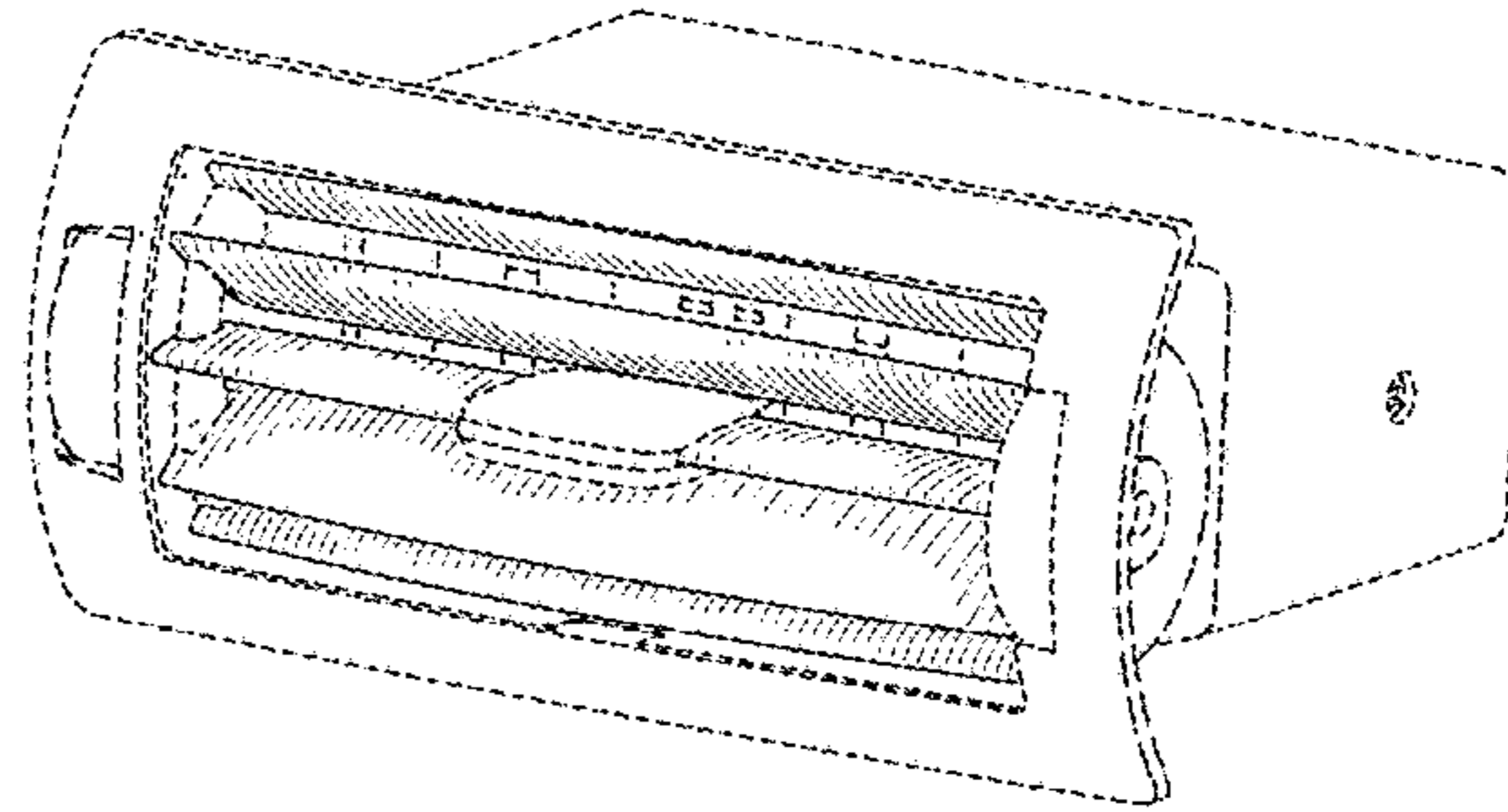
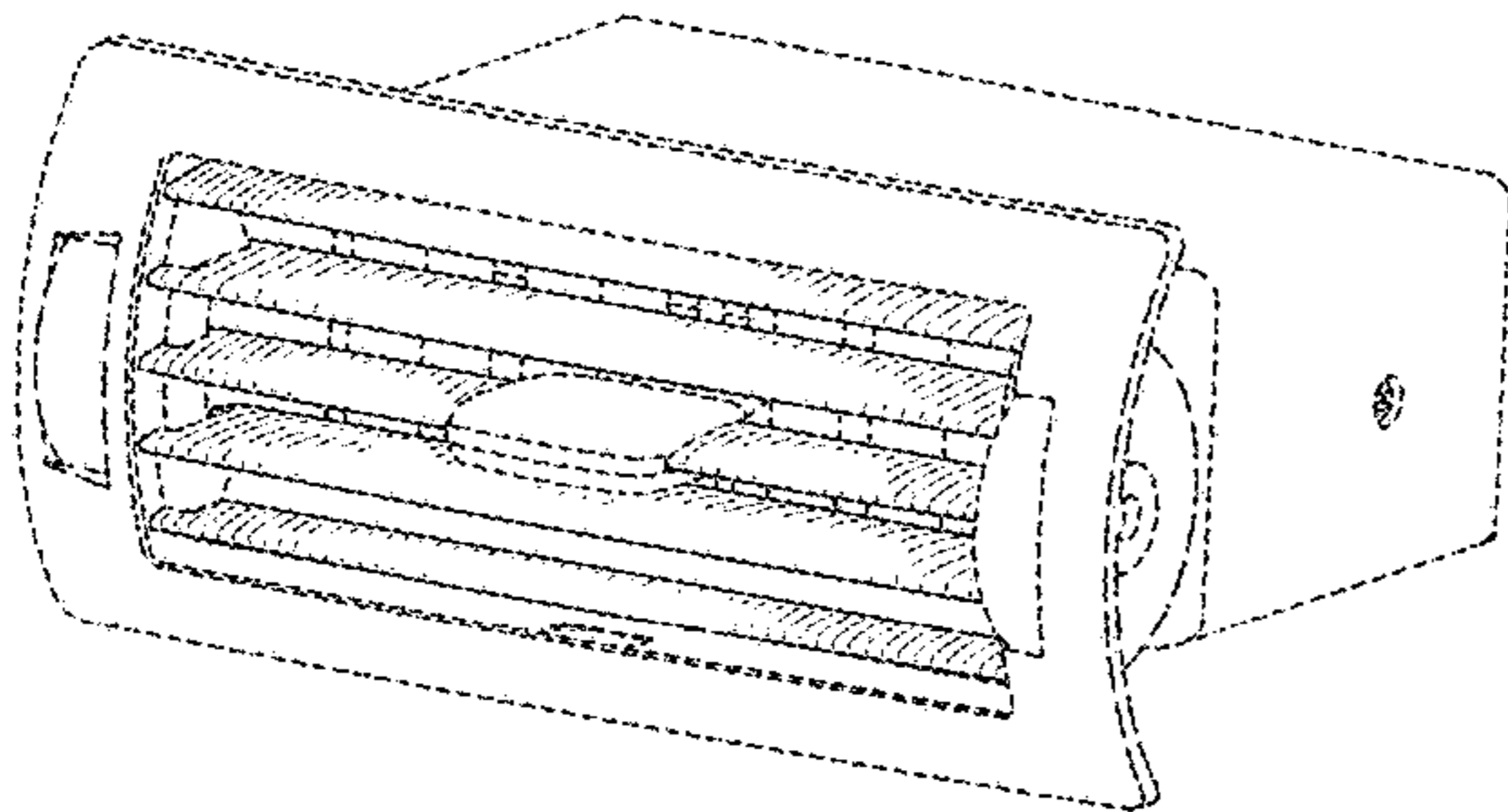

The broken lines depict portions of the air outlet of air conditioner for vehicle that form no part of the claimed design.

**1 Claim, 20 Drawing Sheets**

**(58) Field of Classification Search**

CPC . A61L 9/125; B60H 1/345; B60S 1/54; E04B 1/92; E04B 7/02; F24F 13/06; F24F 1/0011; F24F 1/027; F24F 13/02; F24F 13/10; F24F 13/1426; F24F 13/15; F24F 13/20; E04D 13/10; F04D 25/14; F16L 3/003

See application file for complete search history.

**(56) References Cited**

**U.S. PATENT DOCUMENTS**

2,293,065 A \* 8/1942 Kiczales ..... F24F 13/15  
454/335  
2,509,774 A \* 5/1950 Leigh ..... F24F 13/15  
49/87.1  
2,885,945 A \* 5/1959 Reaney ..... F24F 13/15  
49/408  
3,267,962 A \* 8/1966 Josephson ..... F24F 13/15  
137/601.11  
3,312,159 A \* 4/1967 Shepherd ..... A62C 2/16  
454/369  
3,313,226 A \* 4/1967 Johnson ..... F24F 13/15  
454/319  
3,358,577 A \* 12/1967 Thomson ..... F24F 13/06  
454/320  
3,403,615 A \* 10/1968 Dayus ..... F24F 13/06  
454/309  
3,436,016 A \* 4/1969 Edwards ..... F24F 11/76  
236/49.5  
3,683,786 A \* 8/1972 Hedrick ..... F24F 13/15  
454/313  
3,703,141 A \* 11/1972 Pernoud ..... B60H 1/345  
239/519  
3,783,768 A \* 1/1974 Caming ..... F24F 13/1406  
454/335  
3,894,481 A \* 7/1975 Alley ..... F16K 1/165  
454/318  
4,007,673 A \* 2/1977 Zaloga ..... F24F 13/075  
415/125  
D307,632 S \* 5/1990 Schulz ..... D23/392  
D325,433 S \* 4/1992 Siebert ..... D23/382  
5,188,561 A \* 2/1993 Nissimoff ..... F24F 11/00  
454/256  
D369,420 S \* 4/1996 Haglund ..... D25/38.1  
D413,665 S \* 9/1999 Hudson ..... D23/370  
D446,850 S \* 8/2001 Arlotta ..... D23/393  
D449,680 S \* 10/2001 Arlotta ..... D23/393  
D450,518 S \* 11/2001 Frederick ..... D6/630  
6,389,832 B1 \* 5/2002 Wu ..... B01D 46/0005  
62/201  
D461,235 S \* 8/2002 Arlotta ..... D23/393  
D466,605 S \* 12/2002 Ziegler ..... D23/393  
D468,008 S \* 12/2002 Fraser ..... D23/390  
D521,631 S \* 5/2006 Habensus ..... D23/388  
D542,898 S \* 5/2007 Juraschek ..... D12/192  
D608,432 S \* 1/2010 Aruga ..... D23/358  
D639,416 S \* 6/2011 Jones ..... D23/393  
D723,154 S \* 2/2015 Cheng ..... D23/412  
D736,366 S \* 8/2015 Picco ..... D23/386

D754,830 S \* 4/2016 Huang ..... D23/351  
D755,364 S \* 5/2016 Vogtner ..... D23/388  
D758,257 S \* 6/2016 Platto ..... D12/163  
D761,411 S \* 7/2016 Schanzenbach ..... D23/371  
9,452,820 B1 \* 9/2016 Wirth ..... B64C 3/56  
D783,136 S \* 4/2017 Park ..... D23/351  
D785,158 S \* 4/2017 Kern ..... D23/388  
D787,656 S \* 5/2017 Yoo ..... D23/351  
D788,903 S \* 6/2017 Kern ..... D23/388  
D801,512 S \* 10/2017 Hall ..... D23/388  
D802,742 S \* 11/2017 Sun ..... D23/414  
D816,825 S \* 5/2018 Schanzenbach ..... D23/371  
D817,047 S \* 5/2018 Barnes ..... D6/703.5  
2004/0152411 A1 \* 8/2004 Gehring ..... B60H 1/3414  
454/153  
2005/0042982 A1 \* 2/2005 Okada ..... B60H 1/3421  
454/284  
2005/0056037 A1 \* 3/2005 Park ..... F24F 1/0011  
62/262  
2007/0060040 A1 \* 3/2007 Ogura ..... B60H 1/3421  
454/319  
2008/0138194 A1 \* 6/2008 Wei ..... F04D 25/0613  
415/121.2  
2009/0149124 A1 \* 6/2009 Stevenson ..... B60H 1/00671  
454/358  
2009/0215378 A1 \* 8/2009 Terai ..... B60H 1/3428  
454/152  
2009/0298412 A1 \* 12/2009 Gehring ..... B60H 1/345  
454/153  
2011/0237176 A1 \* 9/2011 Shibata ..... B60H 1/3428  
454/330  
2014/0080399 A1 \* 3/2014 Takai ..... B60H 1/3421  
454/155  
2014/0120826 A1 \* 5/2014 Takai ..... F24F 13/075  
454/318  
2014/0148090 A1 \* 5/2014 Shen ..... G06F 1/20  
454/358  
2015/0065031 A1 \* 3/2015 Shibata ..... B60H 1/3421  
454/322  
2015/0253033 A1 \* 9/2015 Zanqueta ..... F24F 13/20  
312/236  
2015/0328959 A1 \* 11/2015 Suzuki ..... B60H 1/3421  
454/155  
2015/0360536 A1 \* 12/2015 Terai ..... B60H 1/00678  
454/333  
2016/0009163 A1 \* 1/2016 Terai ..... B60H 1/3421  
454/155  
2016/0216000 A1 \* 7/2016 Monahan ..... F24F 13/1413  
2016/0227670 A1 \* 8/2016 Liu ..... H05K 7/20181  
2017/0114545 A1 \* 4/2017 Shopshire ..... E04D 13/178  
2017/0166035 A1 \* 6/2017 Ahn ..... B60H 1/345  
2017/0176045 A1 \* 6/2017 Terai ..... F24F 13/1426  
2017/0259649 A1 \* 9/2017 Shibata ..... B60H 1/3421  
2017/0334266 A1 \* 11/2017 Shibata ..... B60H 1/345  
2018/0023338 A1 \* 1/2018 Werner ..... E04F 10/08  
160/167 R  
2018/0087799 A1 \* 3/2018 Pridemore ..... F24F 11/74

**OTHER PUBLICATIONS**

Kixx Channel, image post date Aug. 16, 2016, site visited May 25, 2018, (online), <<https://kixxman.com/air-coditioner-maintenance-tips/>>.\*  
Tips Mudah Mengecek Kondisi Ac Mobil Supaya Awet, image post date Tue, Jan. 16, 2018, site visited May 25, 2018, (online), <<http://www.turbonesia.com/id/news/detail/tips-mudah-mengecek-kondisi-ac-mobil-supaya-awet/mobilmo>>.\*

\* cited by examiner

FIG. 1

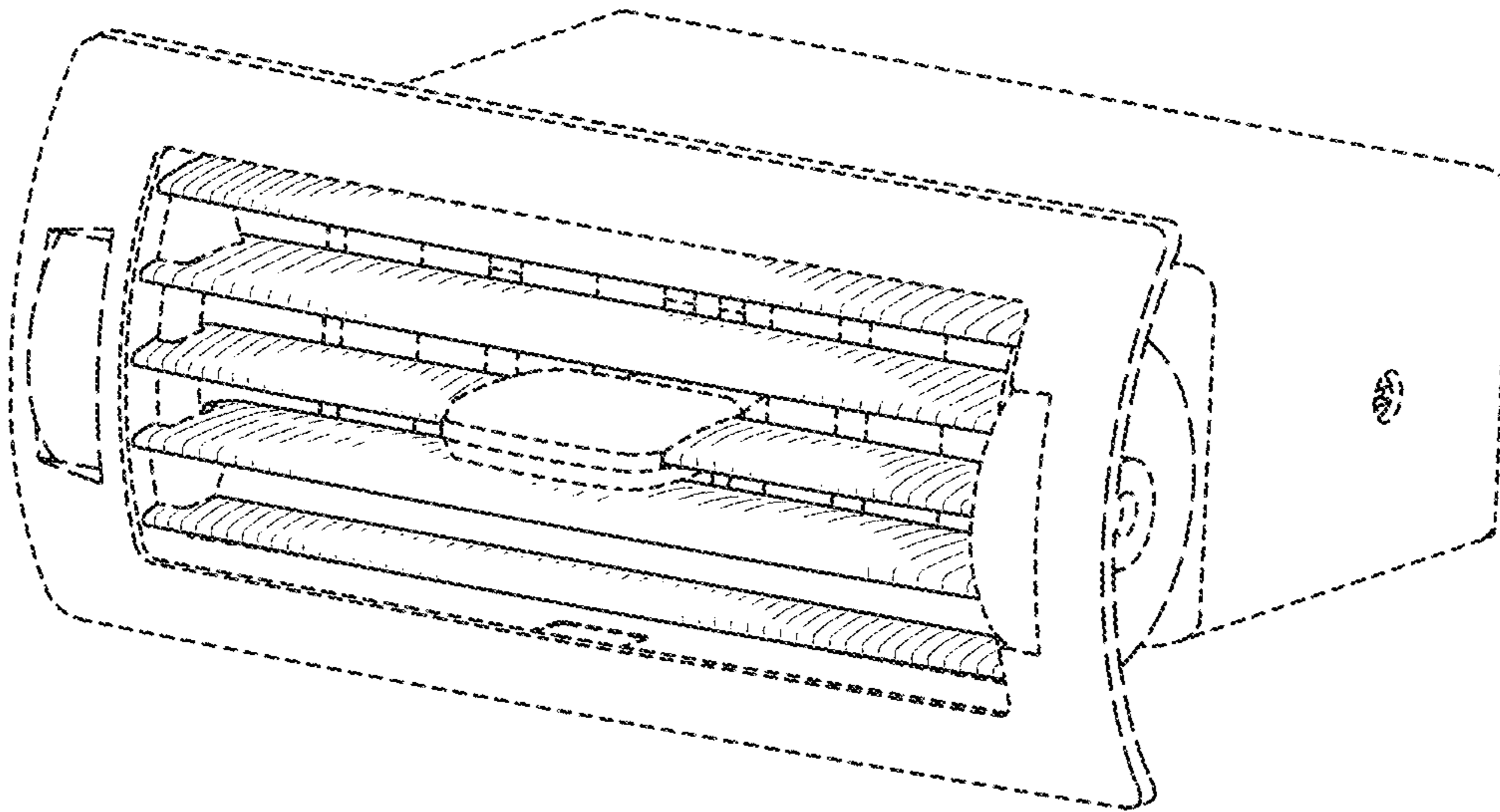

FIG. 2

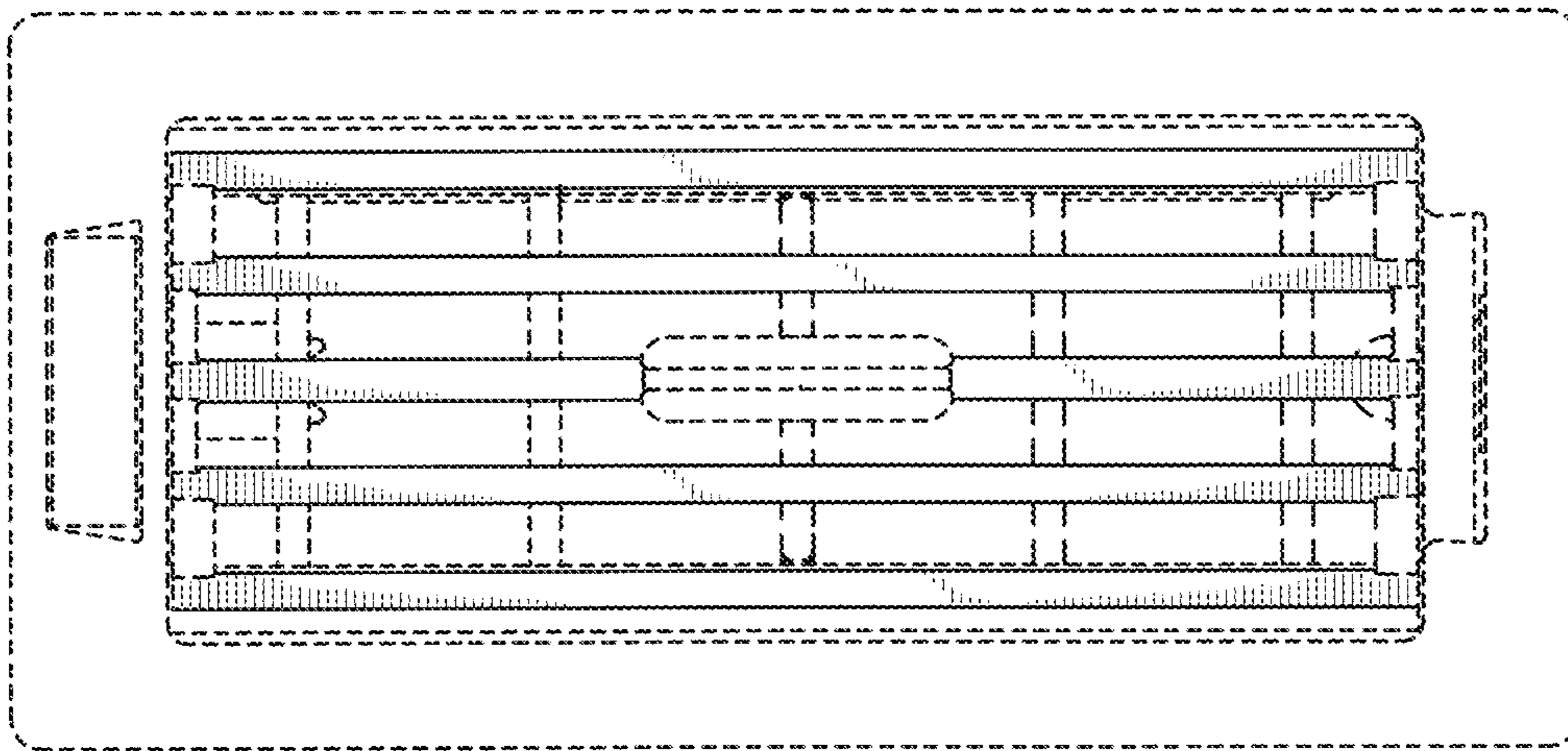

FIG. 3

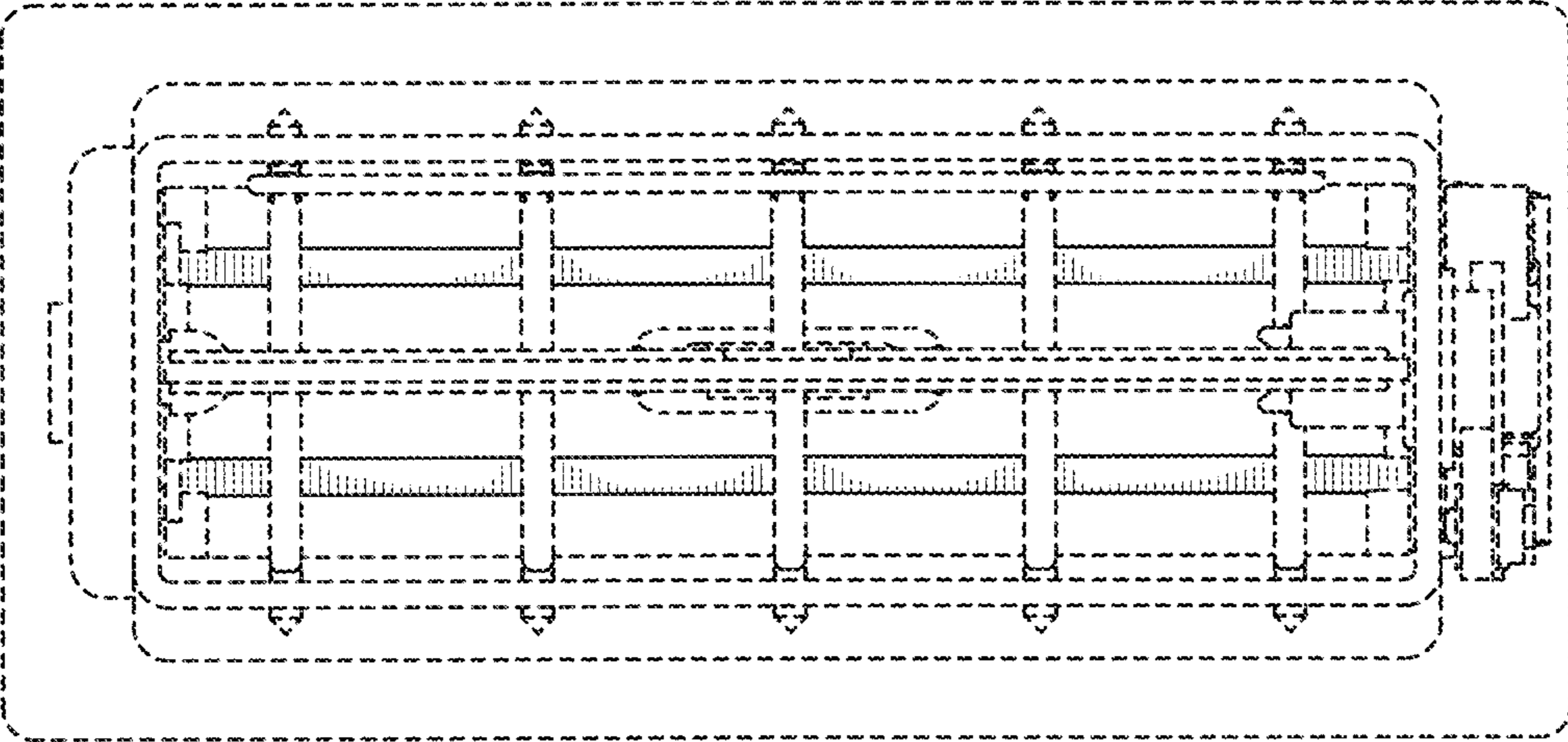

FIG. 4

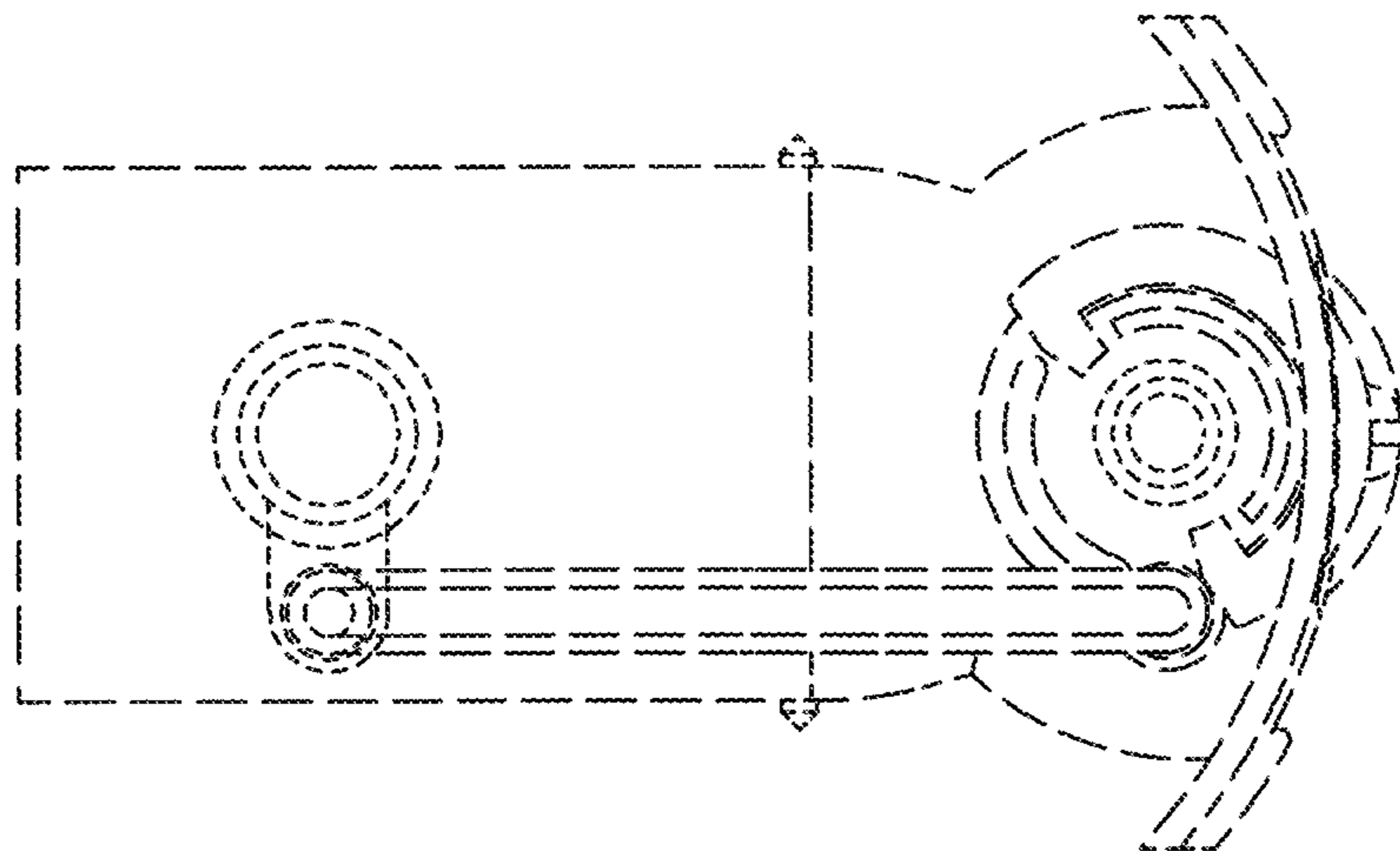

FIG. 5

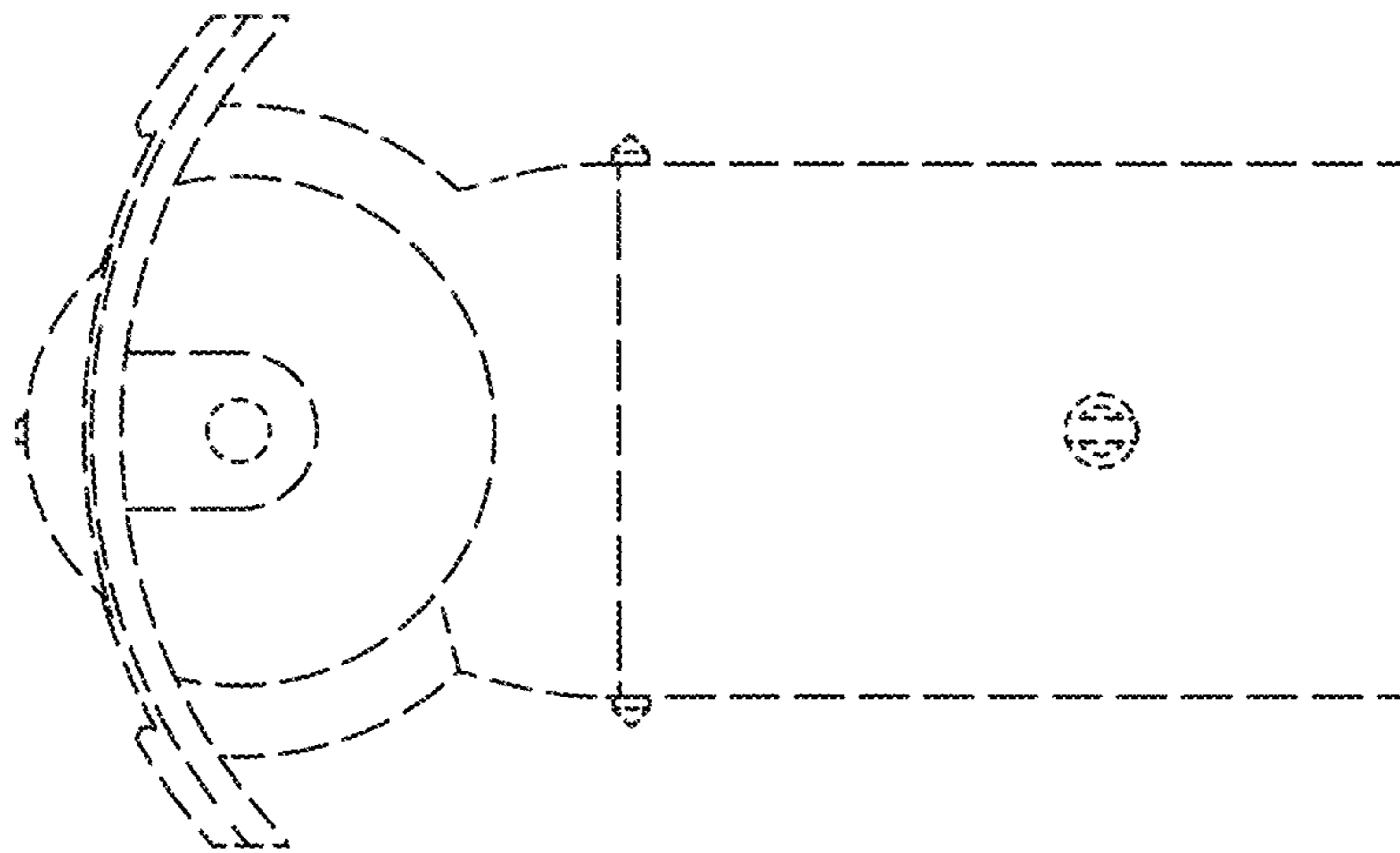

FIG. 6

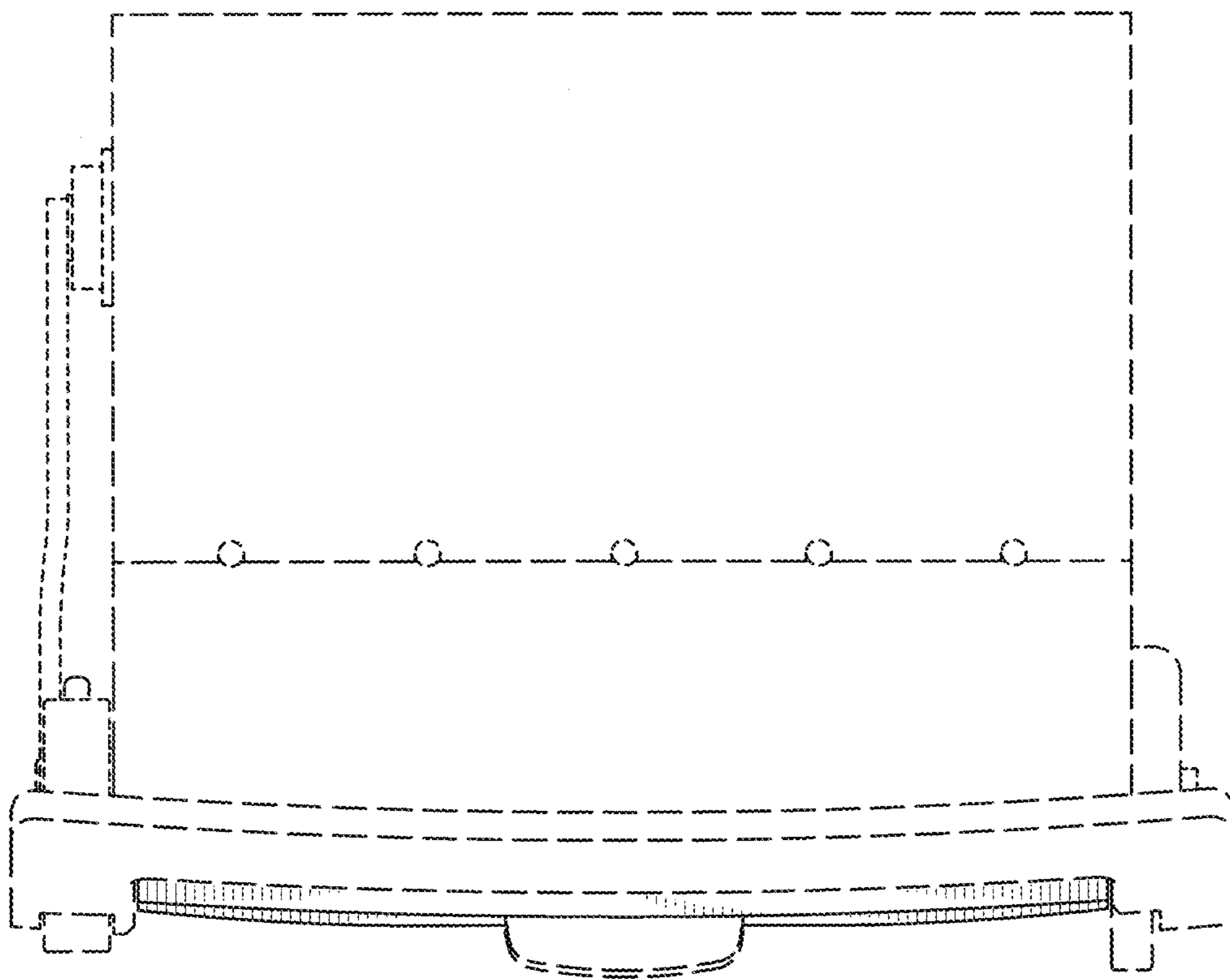



FIG. 7

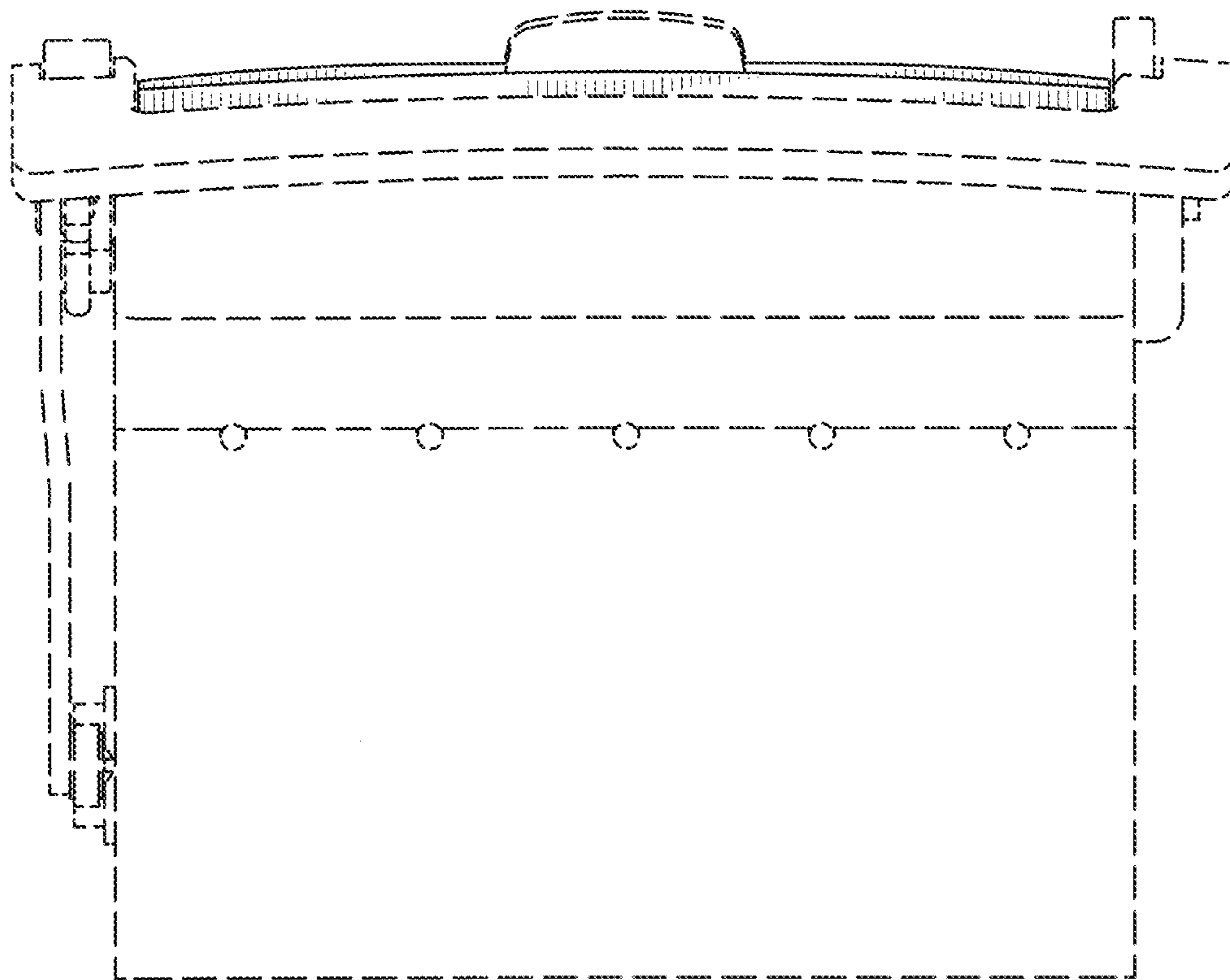

FIG. 8

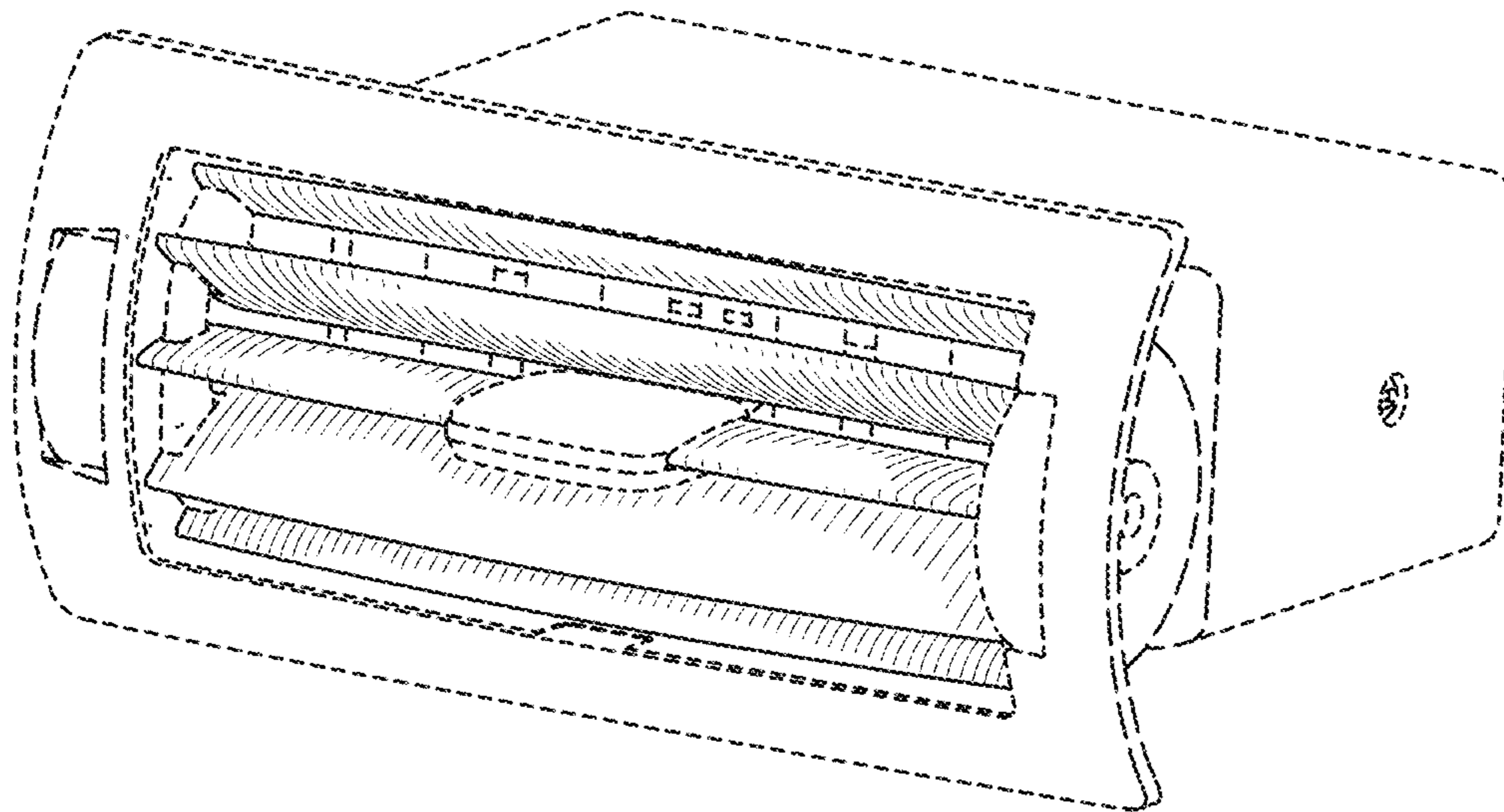

FIG. 9

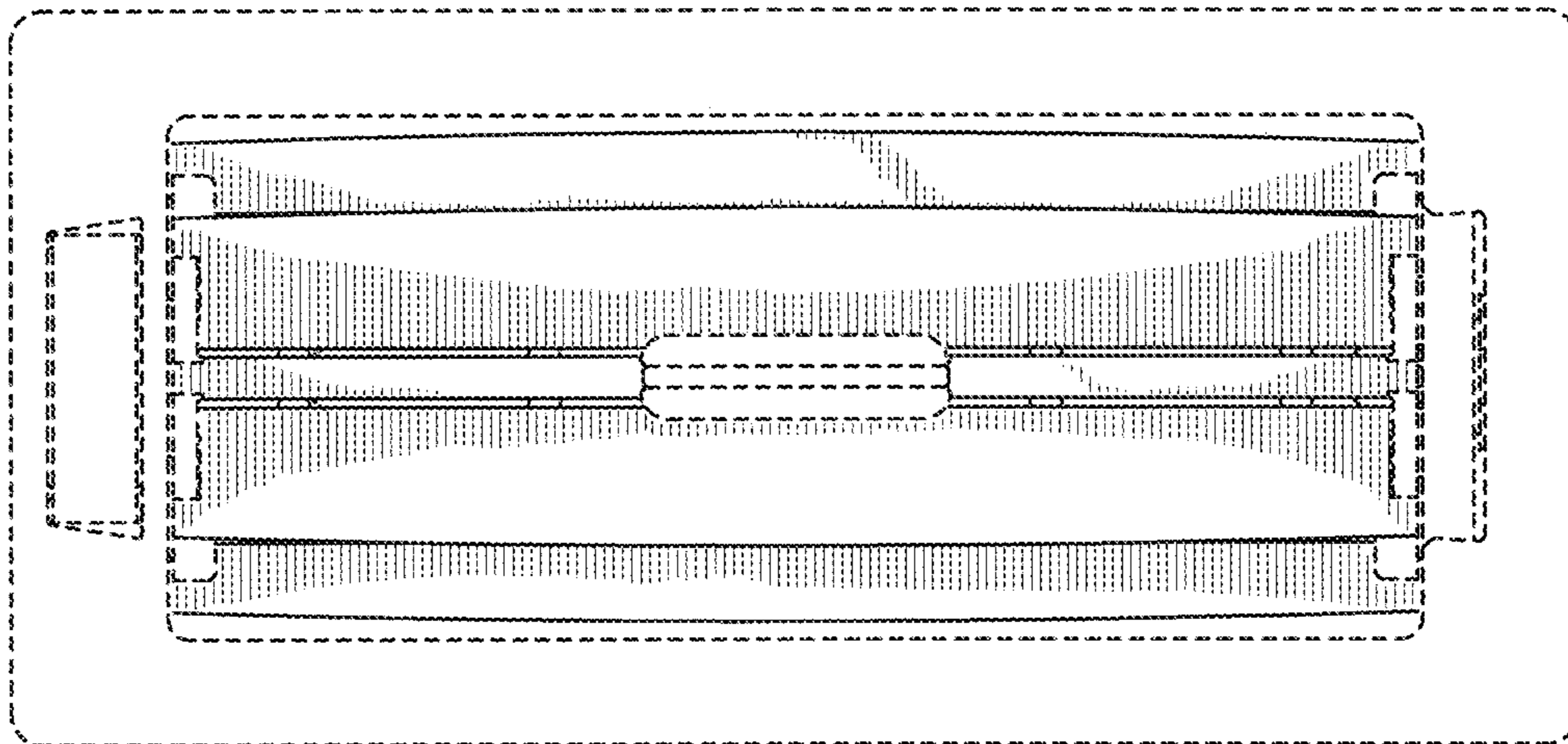

FIG. 10

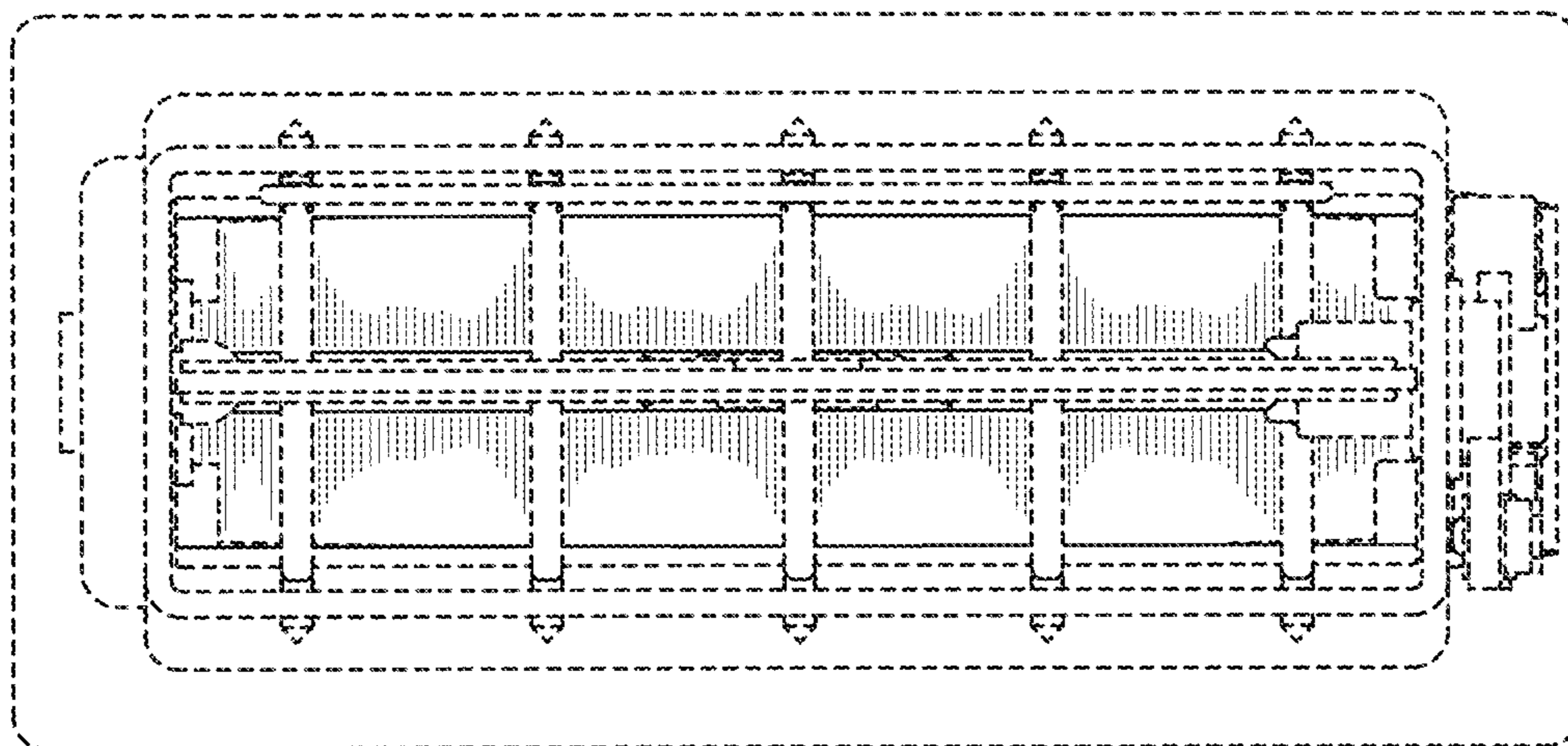

FIG. 11

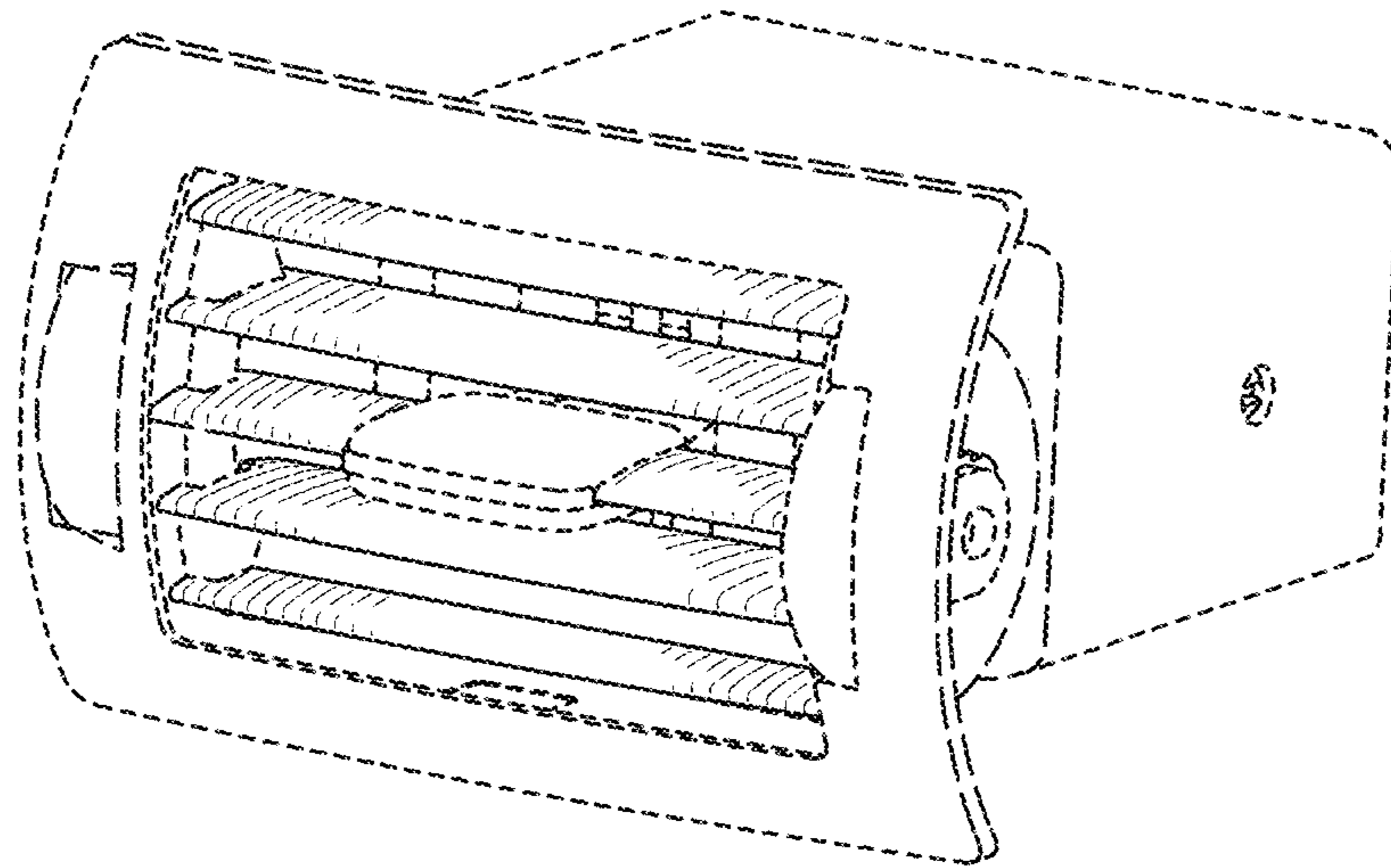

FIG. 12

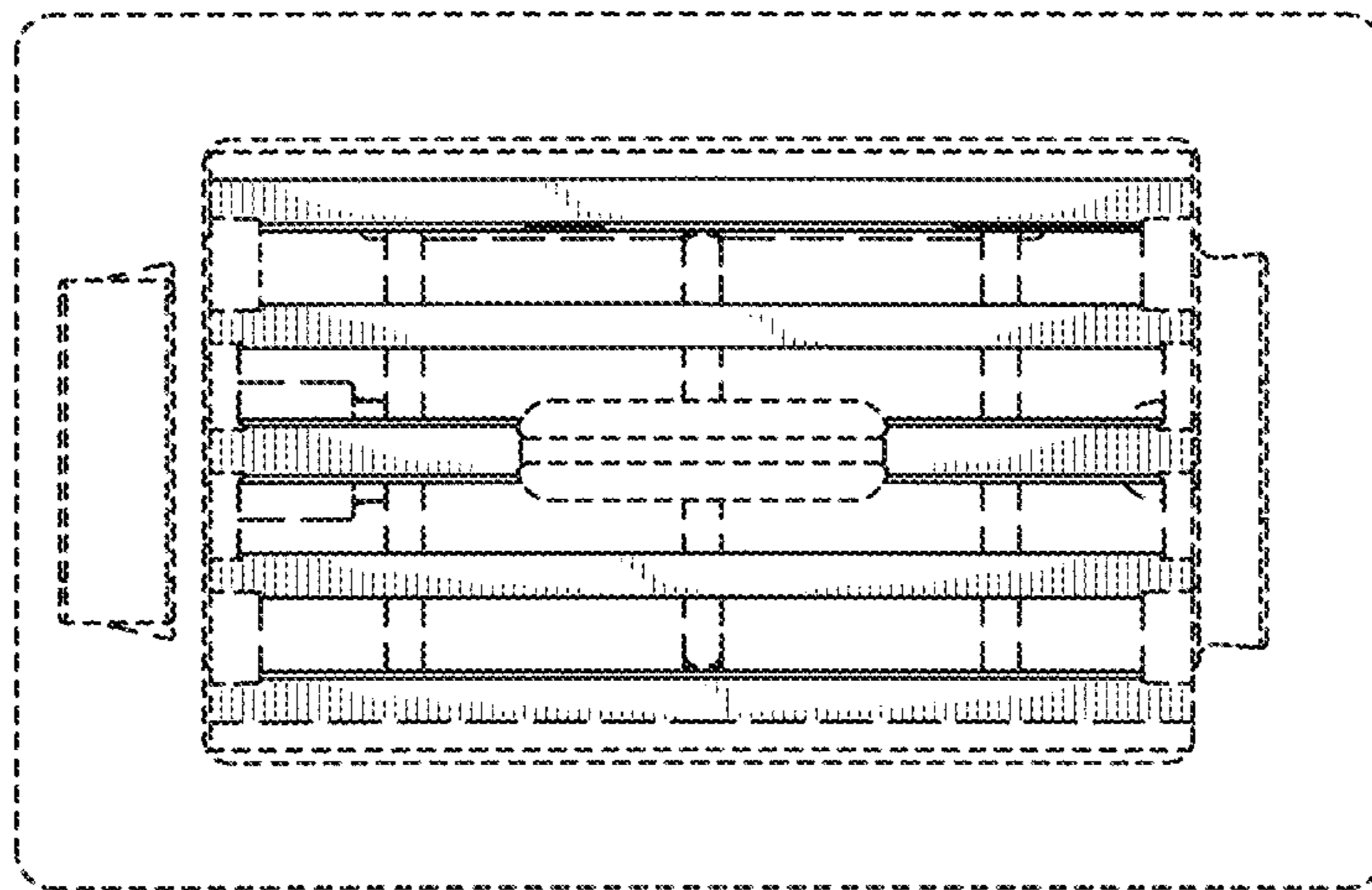

FIG. 13

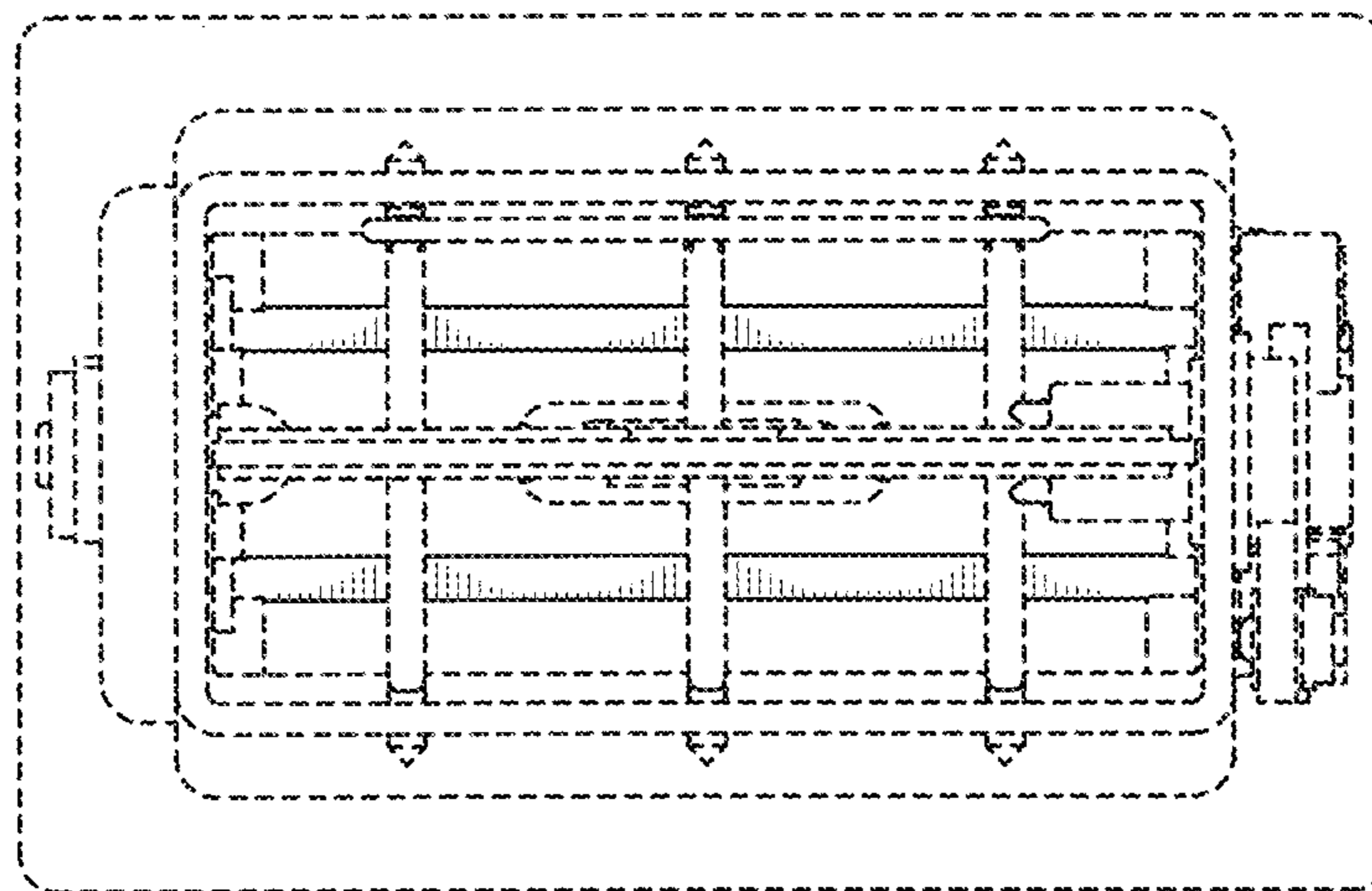

FIG. 14

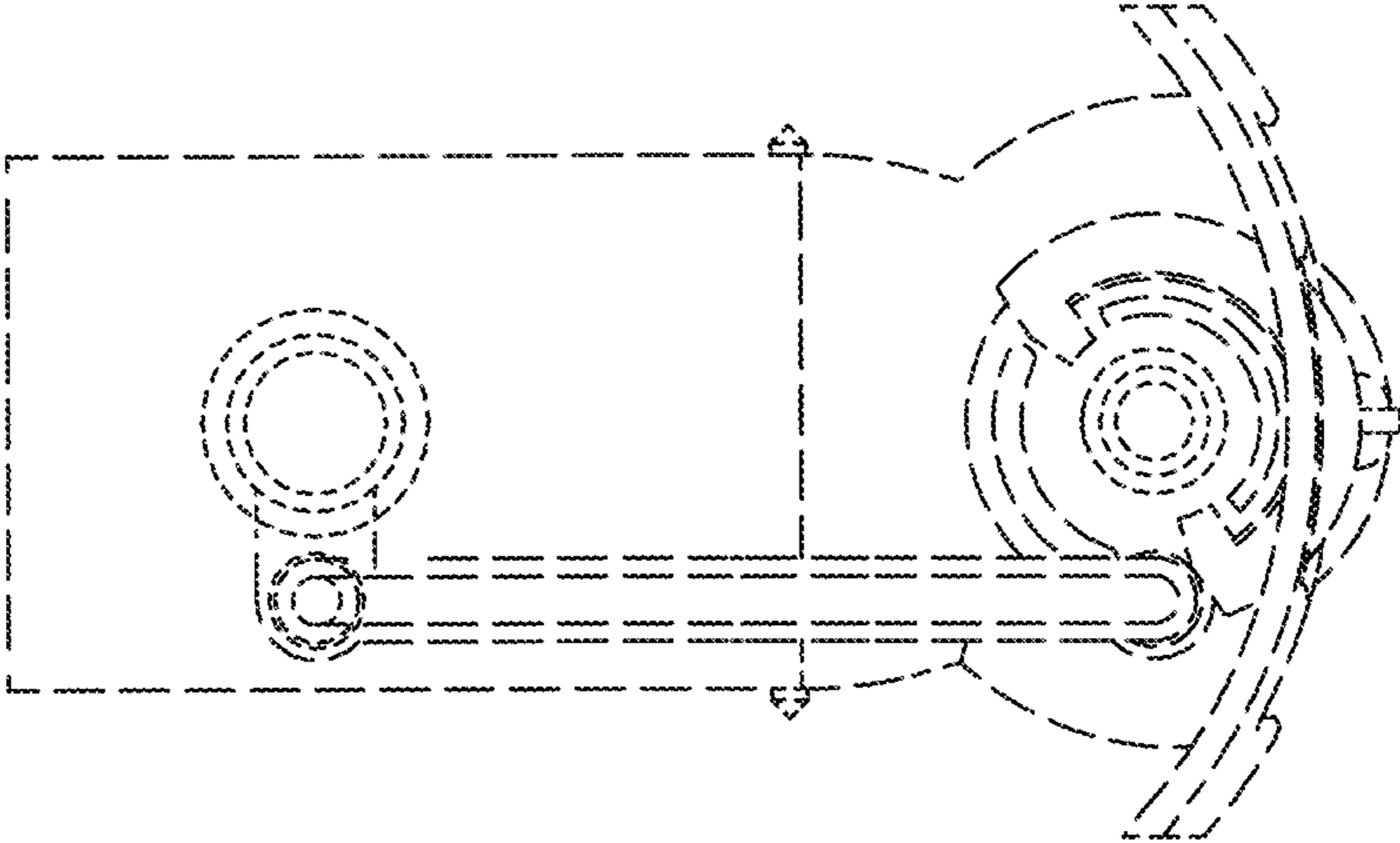



FIG. 15

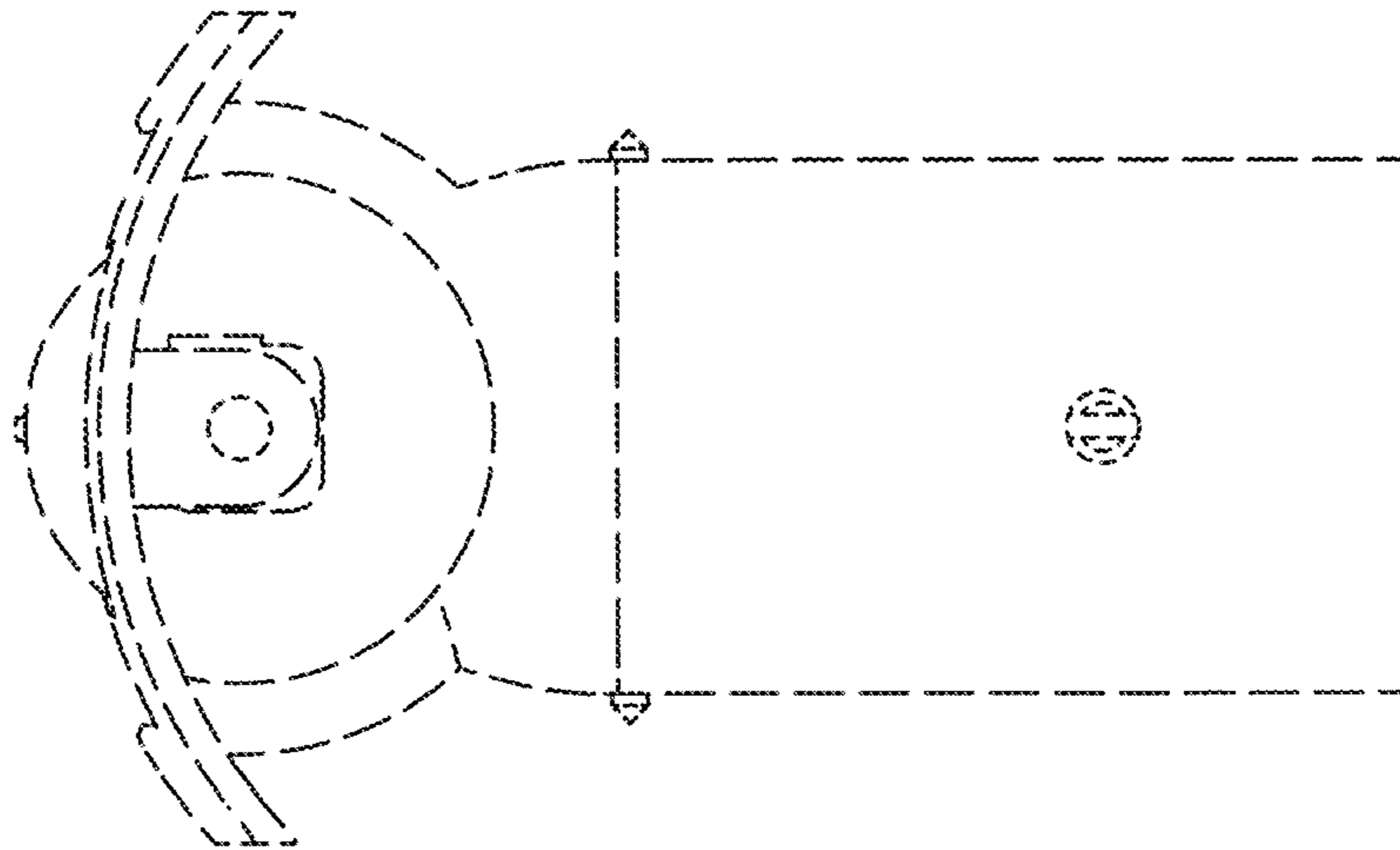

FIG. 16

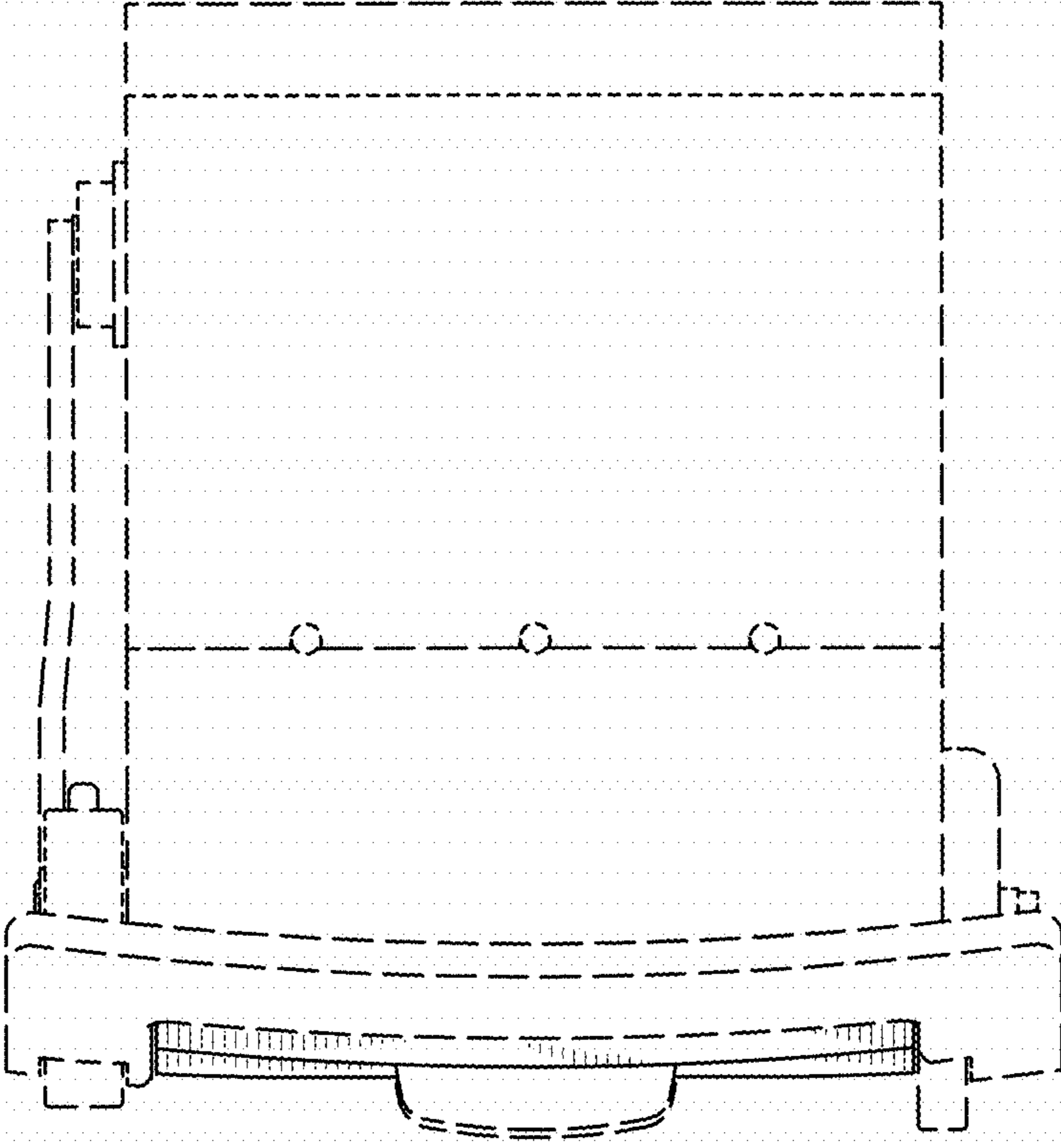

FIG. 17

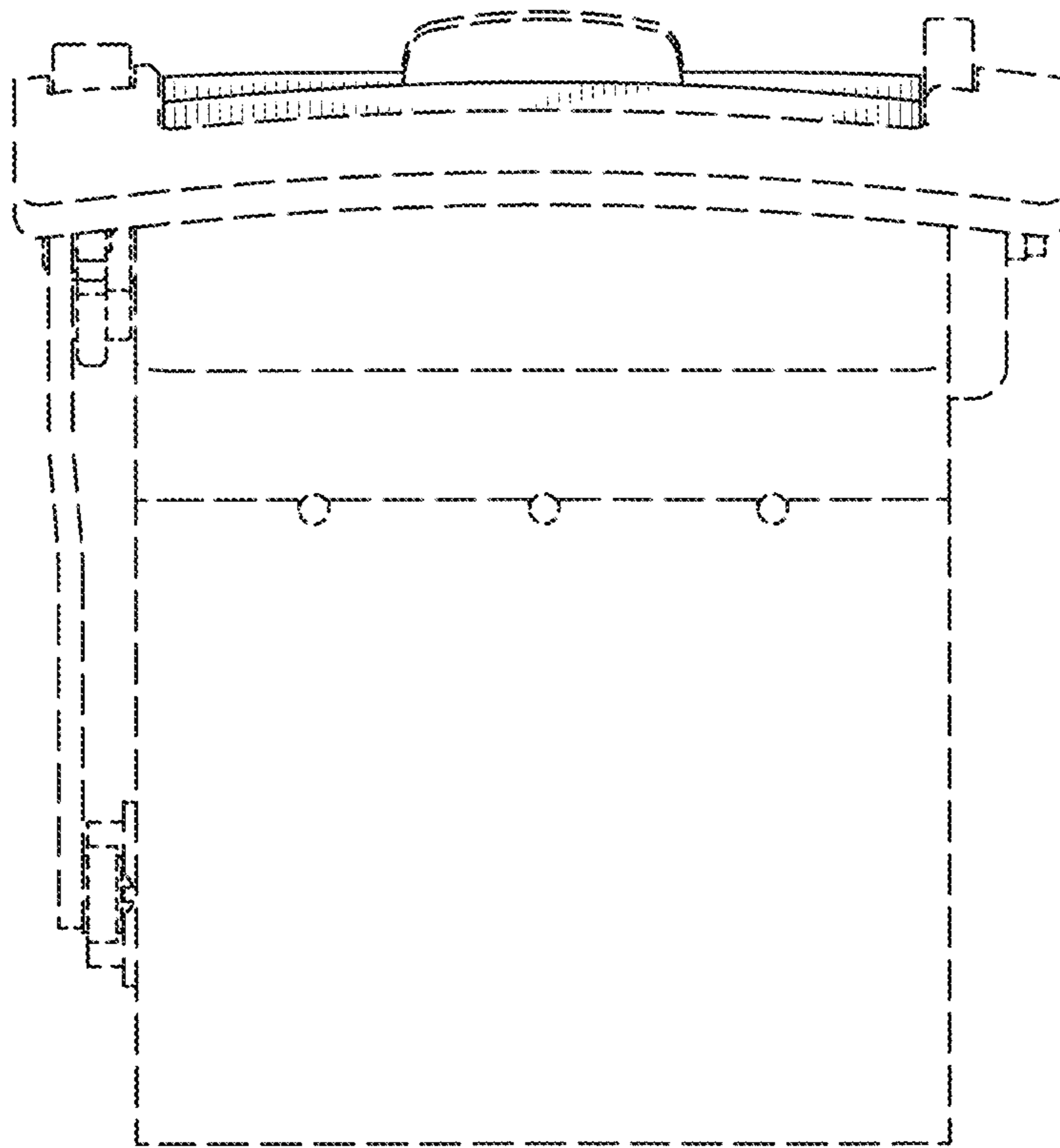

FIG. 18

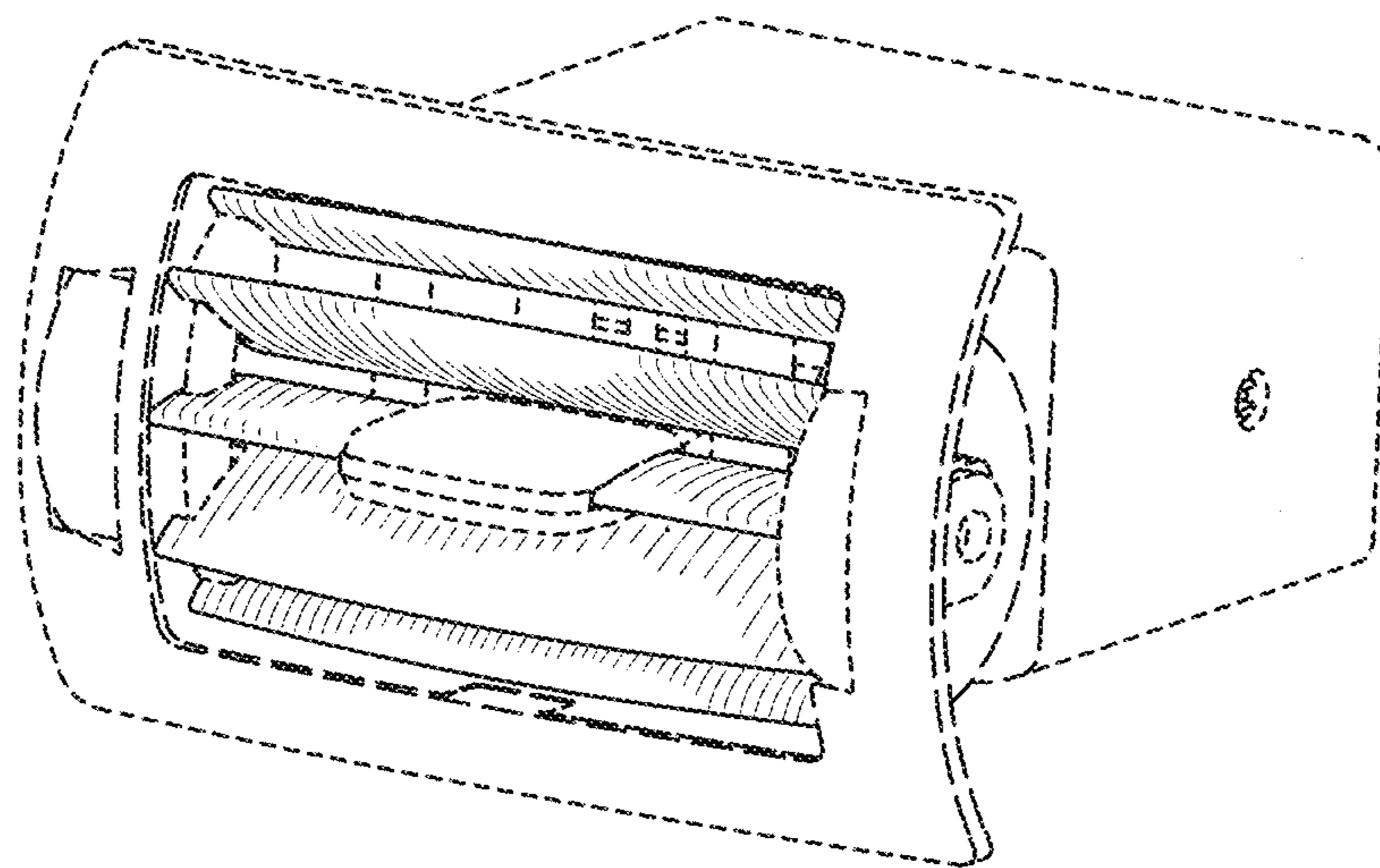

FIG. 19

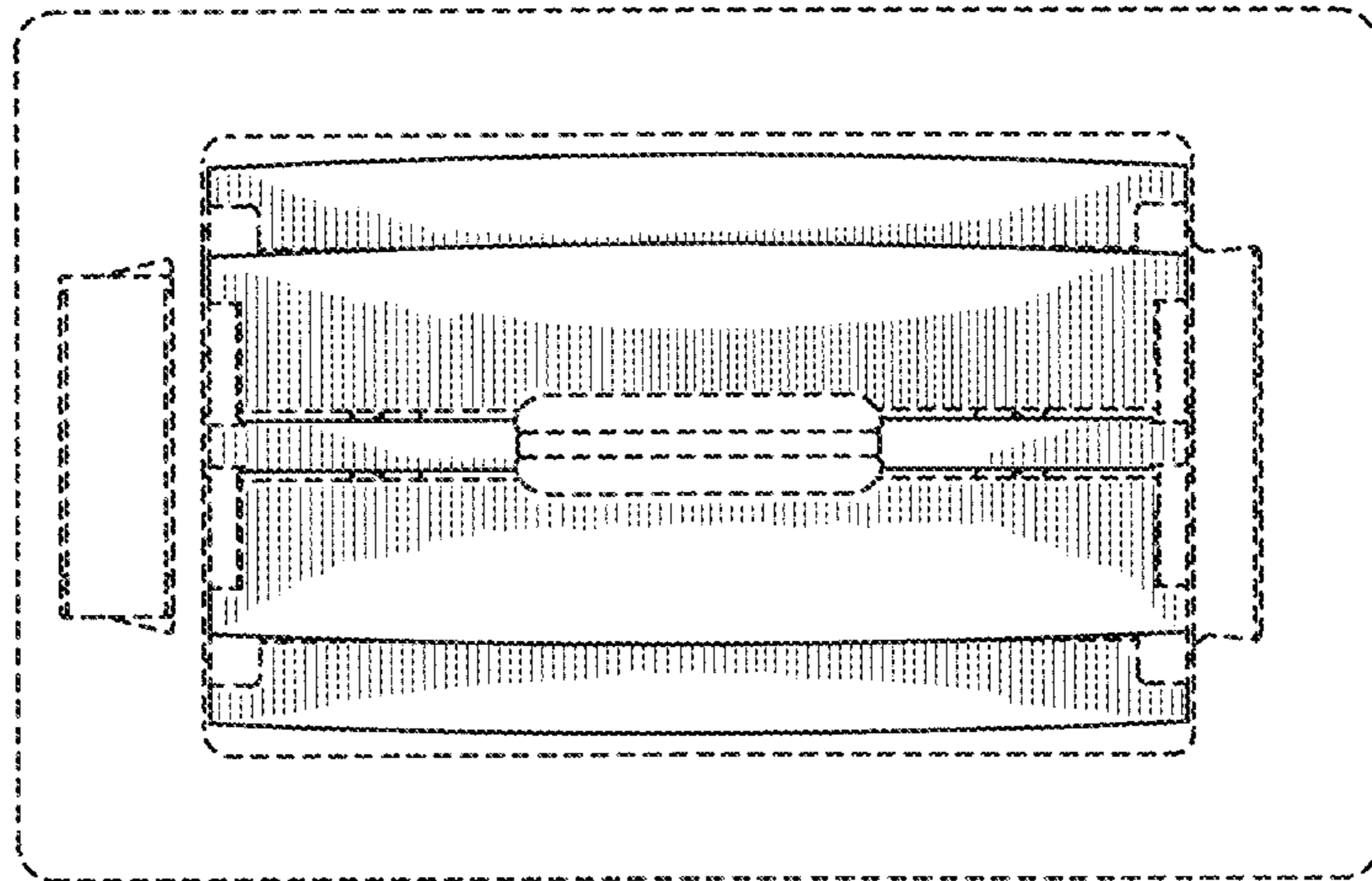

FIG. 20

