



US00D829162S

(12) **United States Design Patent**
Sano et al.

(10) **Patent No.:** **US D829,162 S**
(45) **Date of Patent:** **** Sep. 25, 2018**

- (54) **TIRE**
- (71) Applicant: **Toyo Tire & Rubber Co., Ltd.**,
Osaka-shi, Osaka (JP)
- (72) Inventors: **Shingo Sano**, Osaka (JP); **Toshikazu Yasunaga**, Osaka (JP)
- (73) Assignee: **TOYO TIRE & RUBBER CO., LTD.**,
Osaka (JP)
- (**) Term: **15 Years**
- (21) Appl. No.: **29/599,709**
- (22) Filed: **Apr. 6, 2017**
- (30) **Foreign Application Priority Data**
Oct. 12, 2016 (JP) 2016-022187
- (51) **LOC (11) Cl.** **12-15**
- (52) **U.S. Cl.**
USPC **D12/605**
- (58) **Field of Classification Search**
USPC D12/604-605, 500-501, 506, 534-538,
D12/569-573, 900; D5/30; D7/396.4,
D7/396.5
CPC B06C 13/00; B06C 1/00
See application file for complete search history.

- D768,565 S * 10/2016 Yasunaga D12/605
- D782,407 S * 3/2017 Nagase D12/605
- D791,694 S * 7/2017 Sato D12/605
- D792,340 S * 7/2017 Iwabuchi D12/605
- D800,644 S * 10/2017 Tokizaki D12/605
- D800,645 S * 10/2017 Tokizaki D12/605

(Continued)

FOREIGN PATENT DOCUMENTS

JP	1347759	1/2009
JP	1393599	7/2013

Primary Examiner — Robin Valery Webster
Assistant Examiner — Rachel A Voorhies
 (74) *Attorney, Agent, or Firm* — Sterne, Kessler,
 Goldstein & Fox P.L.L.C.

(57) **CLAIM**

The ornamental design for a tire, as shown and described.

DESCRIPTION

FIG. 1 is a front perspective view of a tire showing the claimed design;
 FIG. 2 is a front view thereof;
 FIG. 3 is a rear view thereof;
 FIG. 4 is a top plan view thereof, the bottom plan view being a mirror image thereof;
 FIG. 5 is a left side view thereof, the right side view being a mirror image thereof;
 FIG. 6 is an enlarged view of the portion between 6-6 and 6'-6' in FIG. 2;
 FIG. 7 is an enlarged cross-sectional view taken along line 7-7 in FIG. 6;
 FIG. 8 is an enlarged view of the portion between 8-8 and 8'-8' in FIG. 2; and,
 FIG. 9 is an enlarged cross-sectional view taken along line 9-9 in FIG. 8.
 In the drawings, the broken lines show portions of the tire that form no part of the claimed design.

1 Claim, 9 Drawing Sheets

(56) **References Cited**

U.S. PATENT DOCUMENTS

- D597,025 S * 7/2009 Fujita D12/605
- D626,502 S * 11/2010 Nakamura D12/605
- D655,671 S * 3/2012 Yasunaga D12/605
- D668,210 S * 10/2012 Sato D12/605
- D669,845 S * 10/2012 Iwabuchi D12/605
- D695,211 S * 12/2013 Yasunaga D12/605
- D710,297 S * 8/2014 Itoi D12/605
- D711,816 S * 8/2014 Iwabuchi D12/605
- D740,220 S * 10/2015 Nakamura D12/605

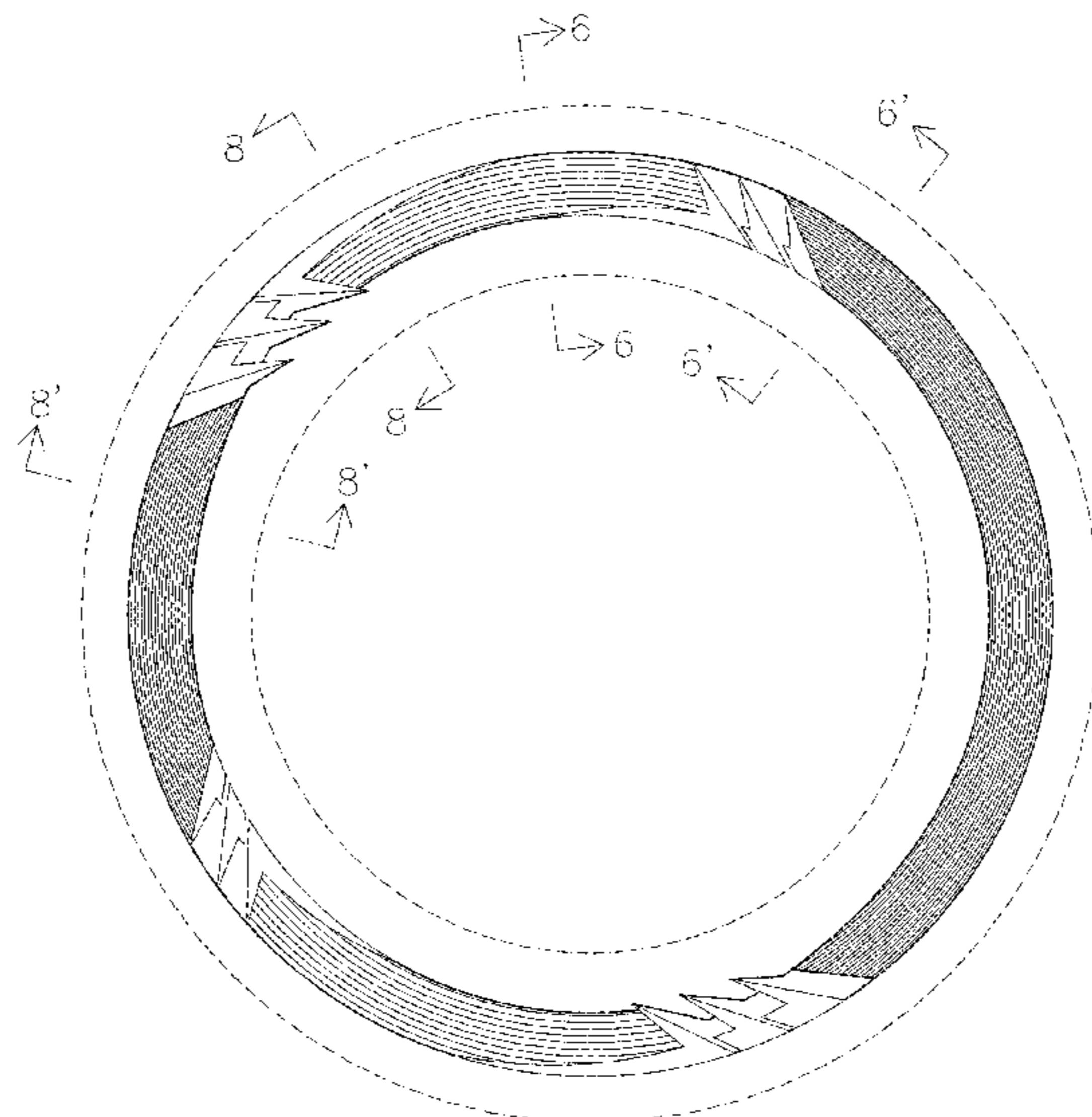

(56)

References Cited

U.S. PATENT DOCUMENTS

D804,402 S * 12/2017 Kamada D12/605
D807,814 S * 1/2018 Yamakawa D12/604

* cited by examiner

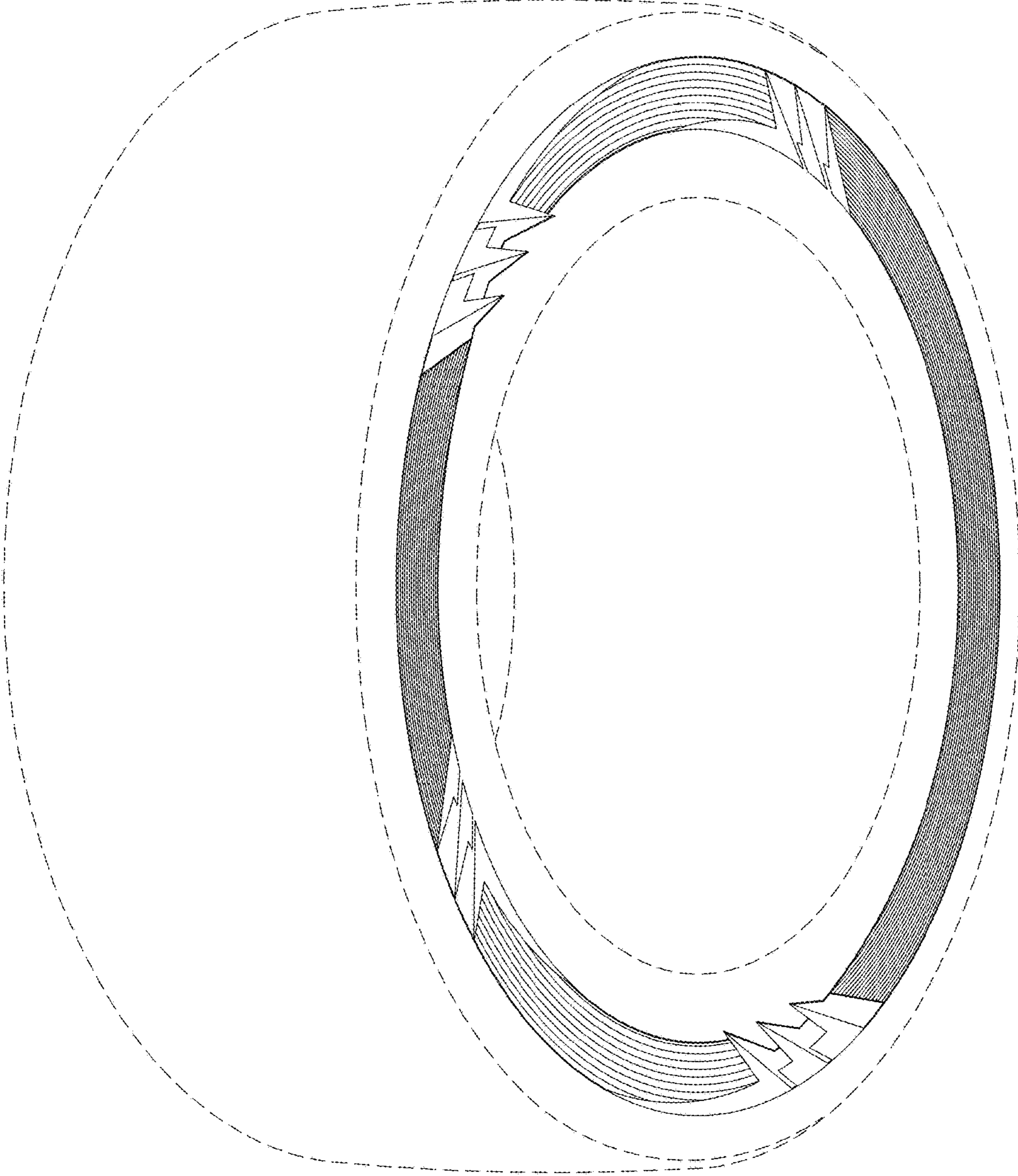

FIG. 1

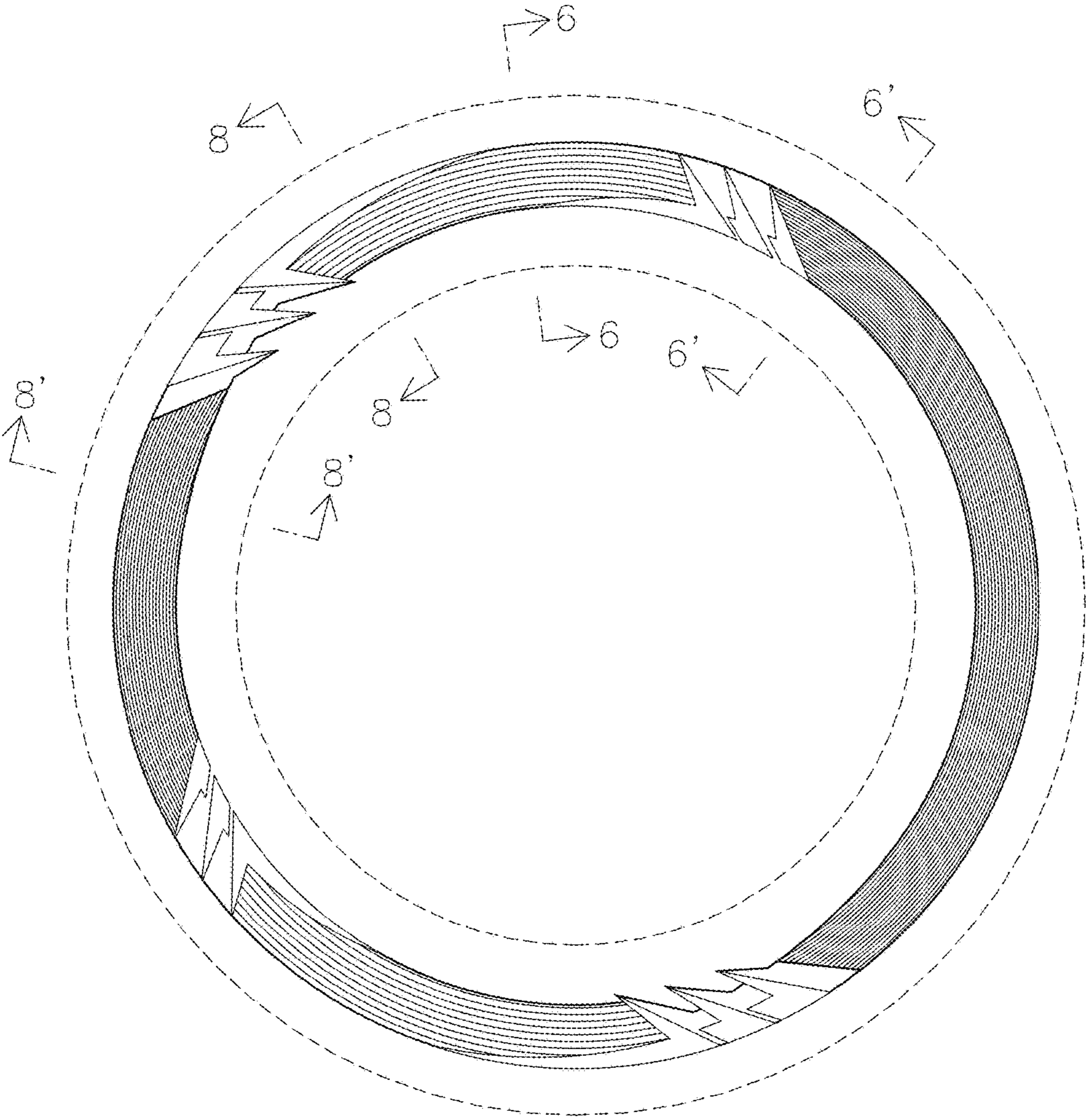

FIG. 2

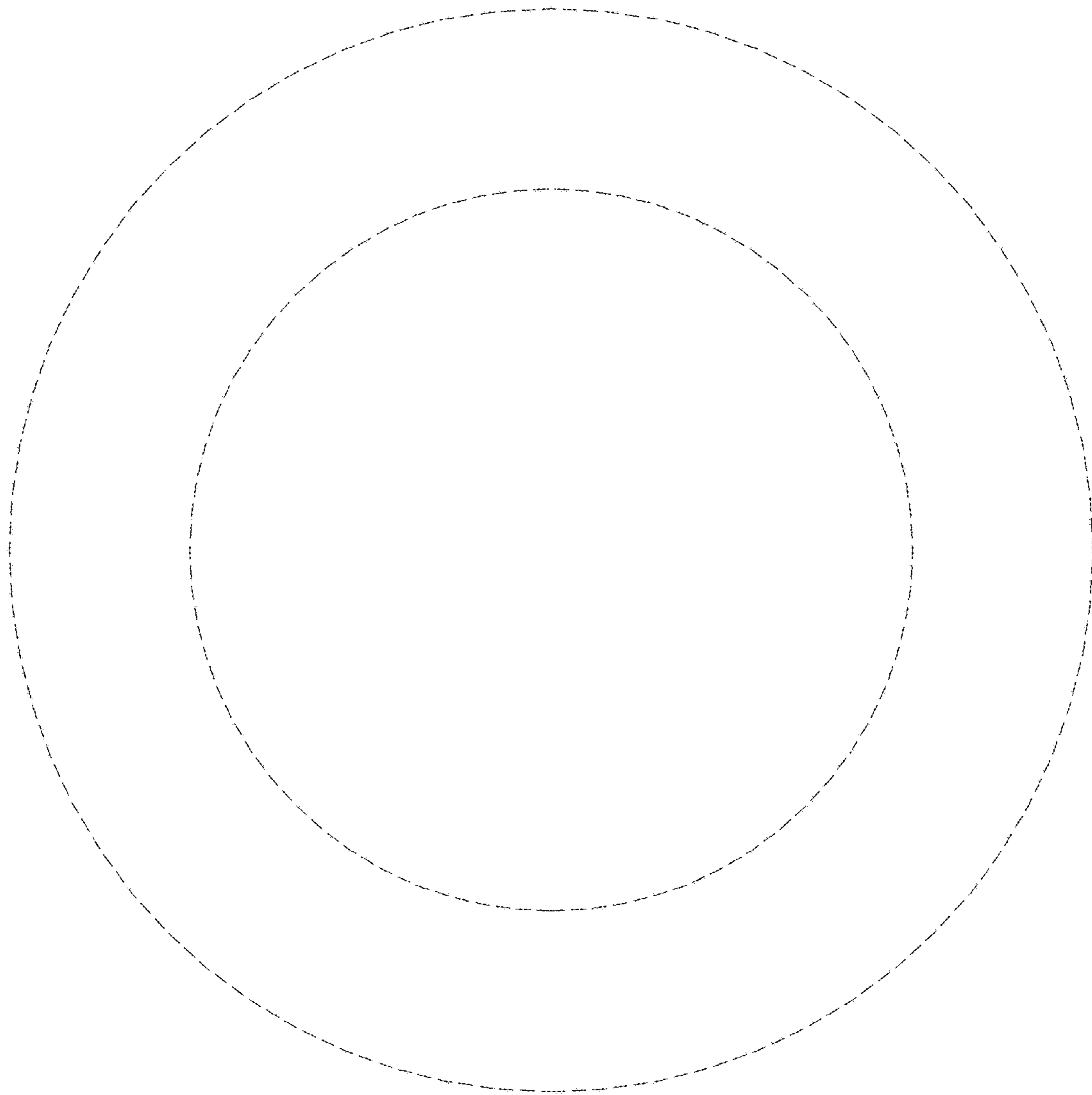

FIG. 3

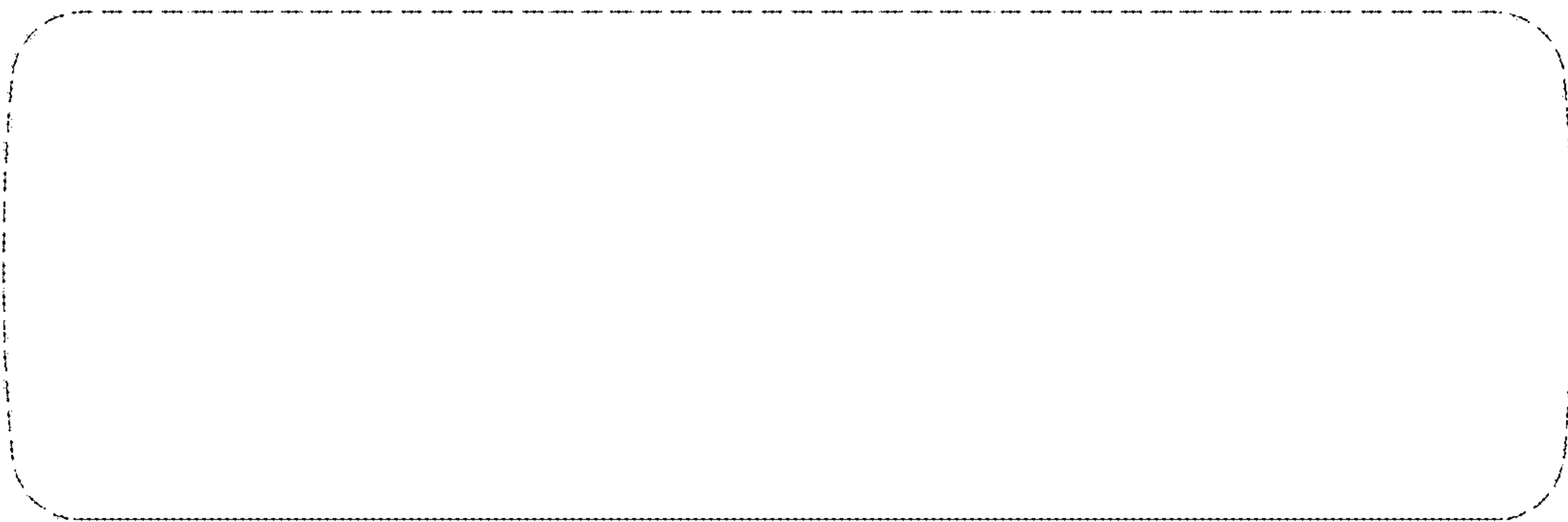

FIG. 4

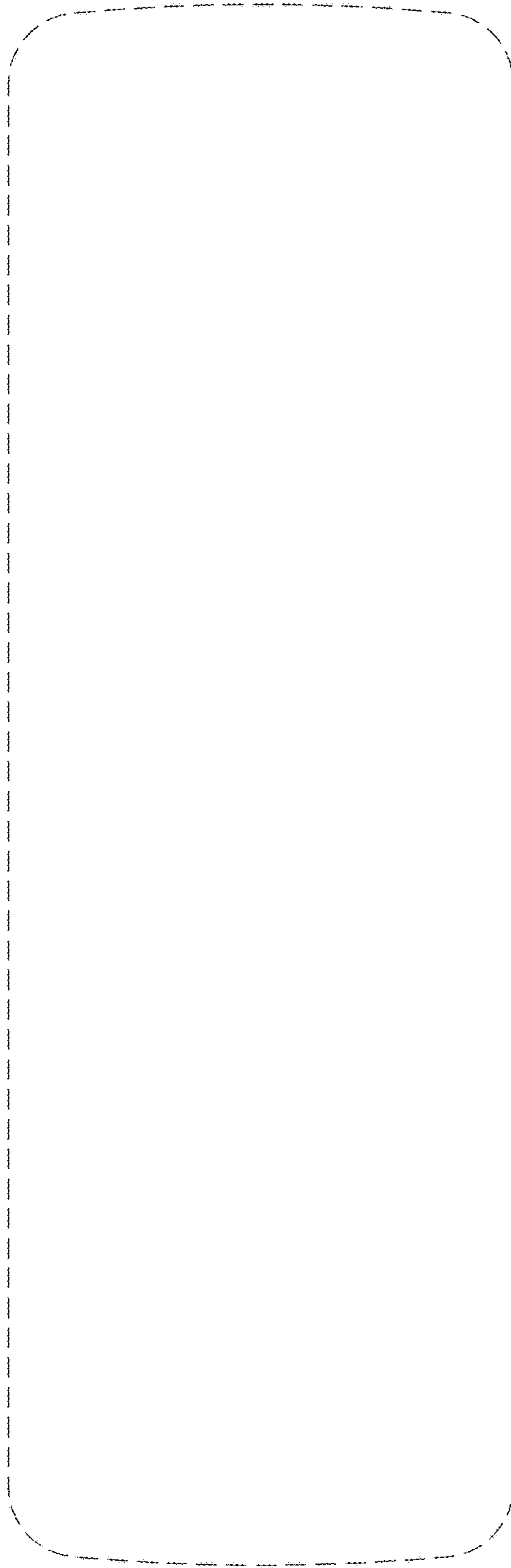

FIG. 5

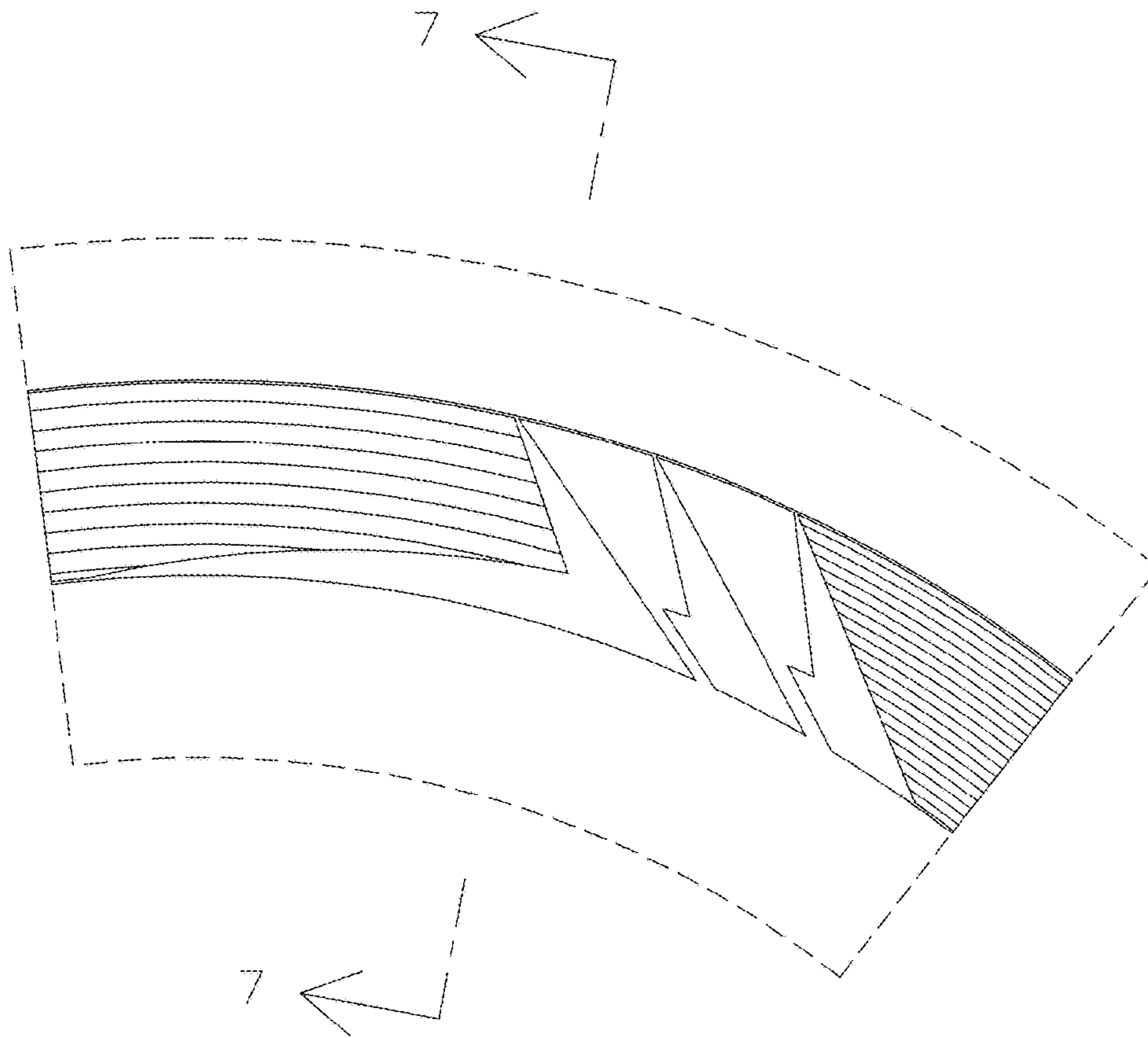

FIG. 6

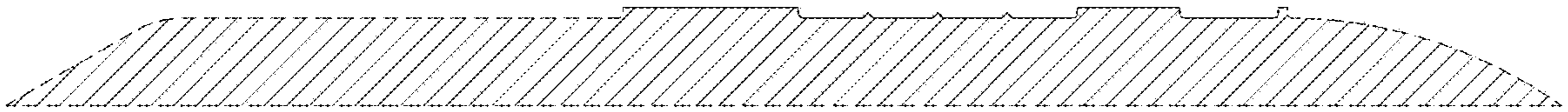

FIG. 7

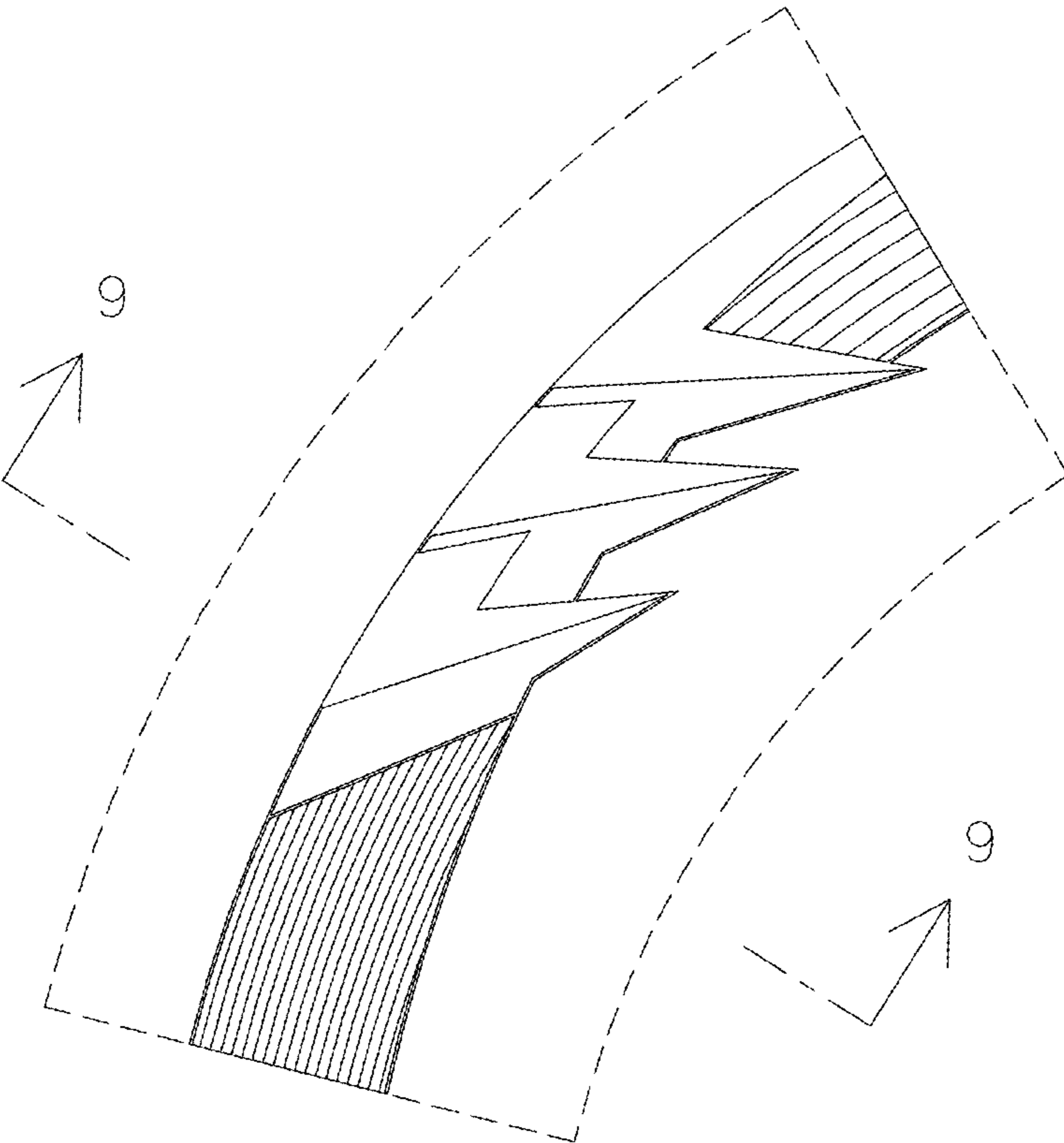

FIG. 8

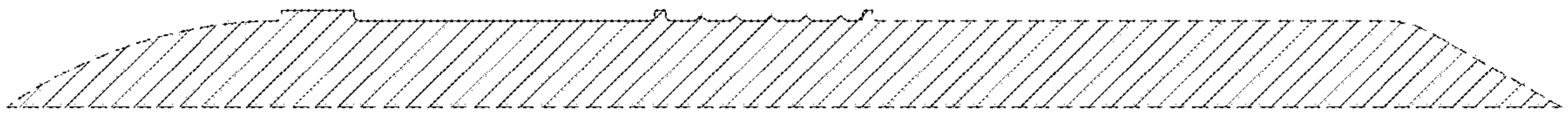

FIG. 9