



US00D828936S

(12) **United States Design Patent**
Huang

(10) **Patent No.:** **US D828,936 S**

(45) **Date of Patent:** **** Sep. 18, 2018**

(54) **VEHICLE LAMP**

(71) Applicant: **Sirius Light Technology Co., LTD.**,
Tainan (TW)

(72) Inventor: **Cheng-Nan Huang**, Tainan (TW)

(73) Assignee: **Sirius Light Technology Co., LTD.**,
Tainan (TW)

(**) Term: **15 Years**

(21) Appl. No.: **29/622,429**

(22) Filed: **Oct. 17, 2017**

(30) **Foreign Application Priority Data**

Aug. 31, 2017 (TW) 106305031

(51) **LOC (11) Cl.** **26-06**

(52) **U.S. Cl.**
USPC **D26/28**

(58) **Field of Classification Search**
USPC D26/28-36; 362/80-83, 267-269,
362/459-468, 475-478, 485-487
CPC F21S 48/00; F21S 48/10; F21S 48/115;
F21S 48/225; F21S 48/1233; F21S
48/1266; F21S 48/1388; F21S 48/2268;
F21V 21/04

See application file for complete search history.

(56) **References Cited**

U.S. PATENT DOCUMENTS

D570,012 S *	5/2008	Huang	D26/28
D578,677 S *	10/2008	Huang	D26/28
D578,678 S *	10/2008	Huang	D26/28
D578,680 S *	10/2008	Huang	D26/28
D586,486 S *	2/2009	DiPenti	D26/28
D711,565 S *	8/2014	Tsai	D26/28

* cited by examiner

Primary Examiner — Marcus Jackson

(74) *Attorney, Agent, or Firm* — LeClairRyan

(57) **CLAIM**

The ornamental design for a vehicle lamp, as shown and described.

DESCRIPTION

FIG. 1 is a perspective view of a vehicle lamp showing my new design;

FIG. 2 is a front elevational view thereof;

FIG. 3 is a rear elevational view thereof;

FIG. 4 is a left side elevational view thereof;

FIG. 5 is a right side elevational view thereof;

FIG. 6 is a top plan view thereof; and,

FIG. 7 is a bottom plan view thereof.

The broken lines depict portions of a vehicle lamp in which the design is embodied that form no part of the claimed design.

1 Claim, 5 Drawing Sheets

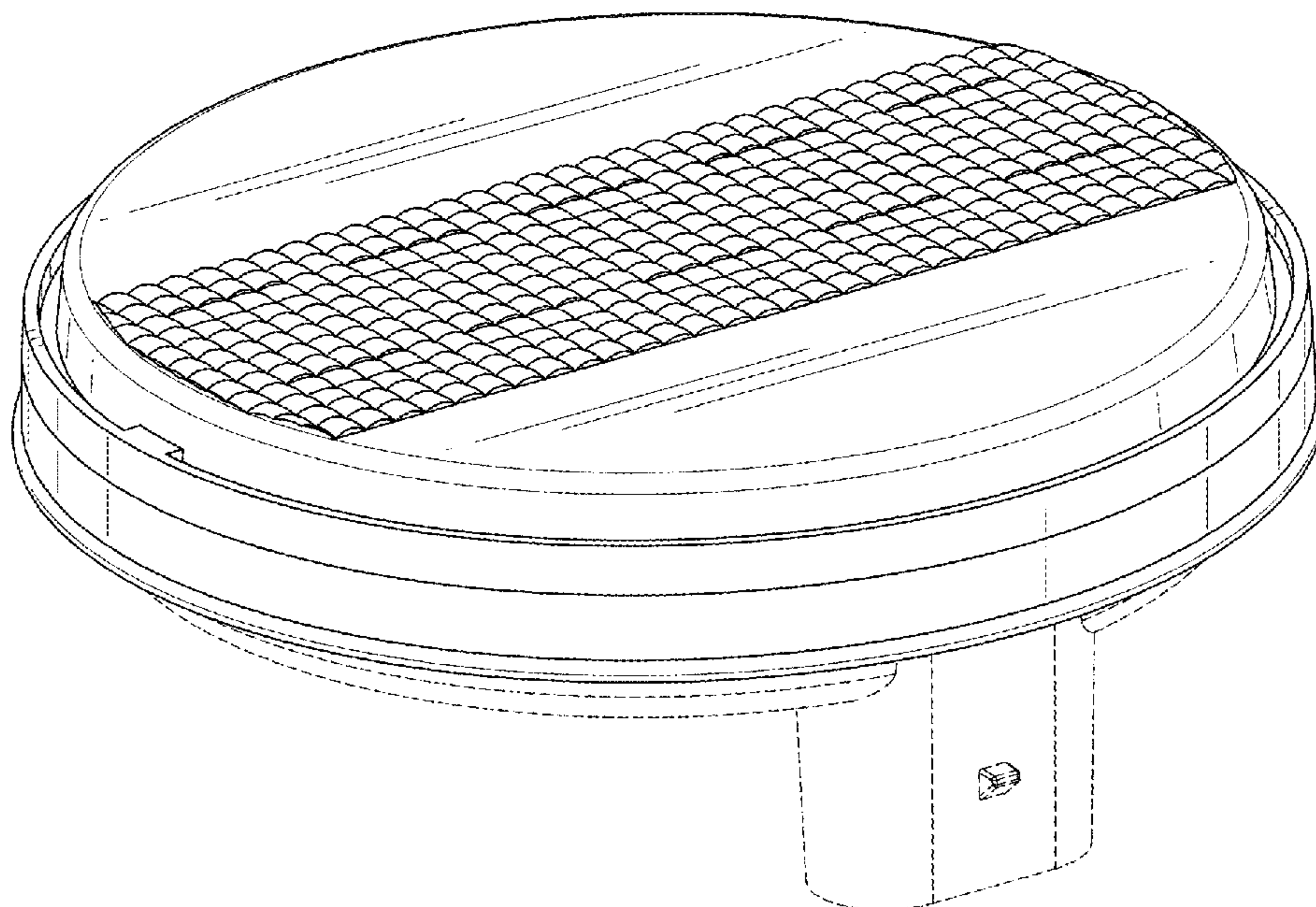

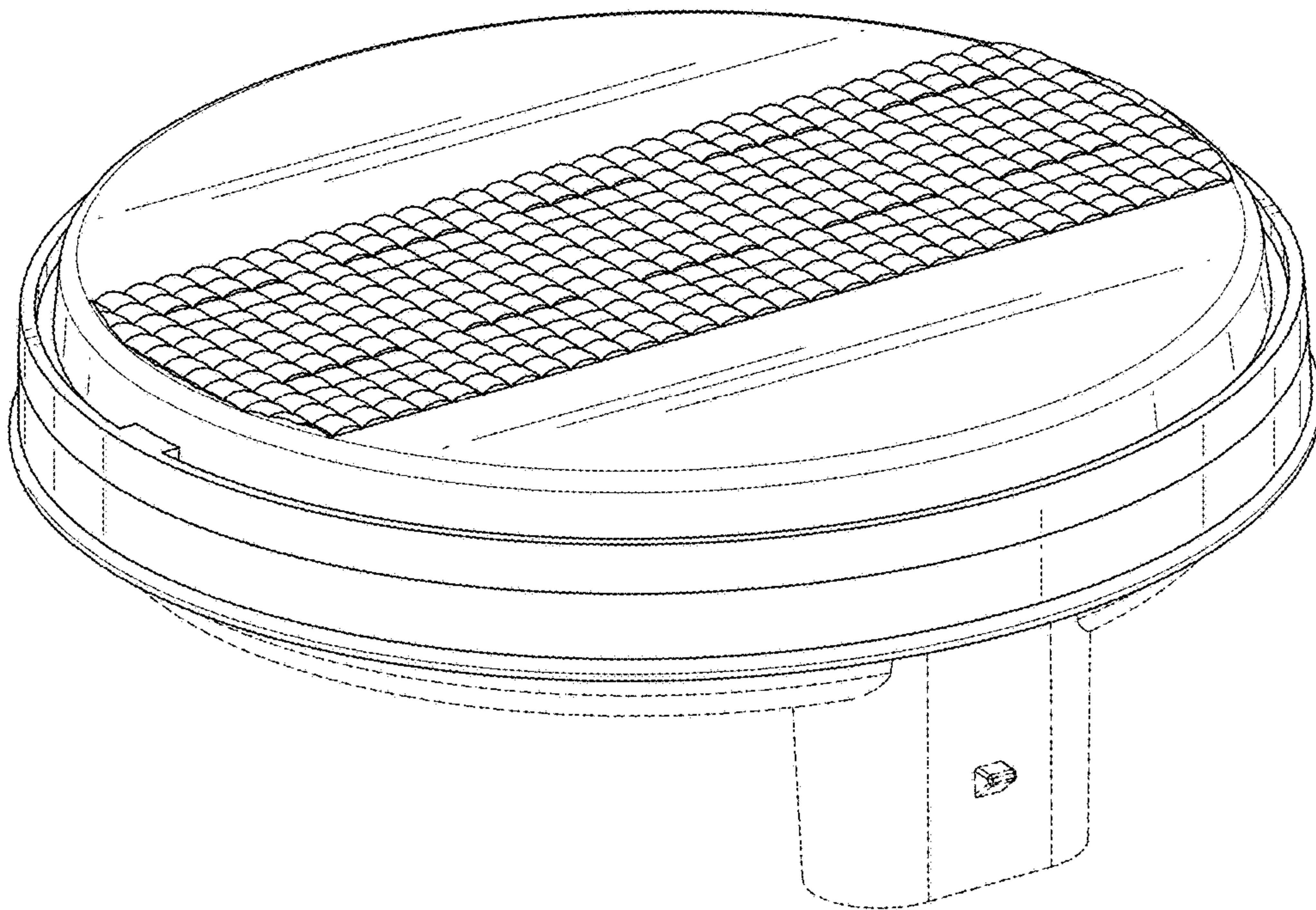

FIG.1

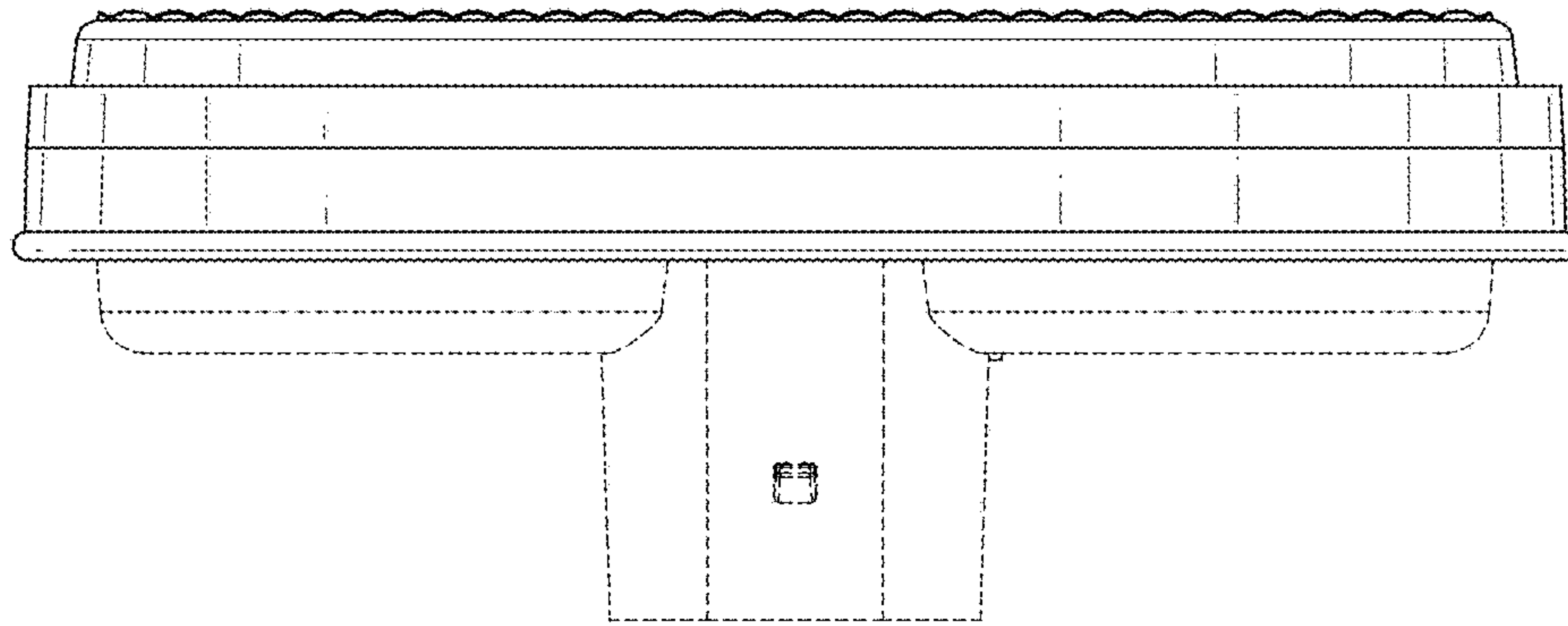

FIG. 2

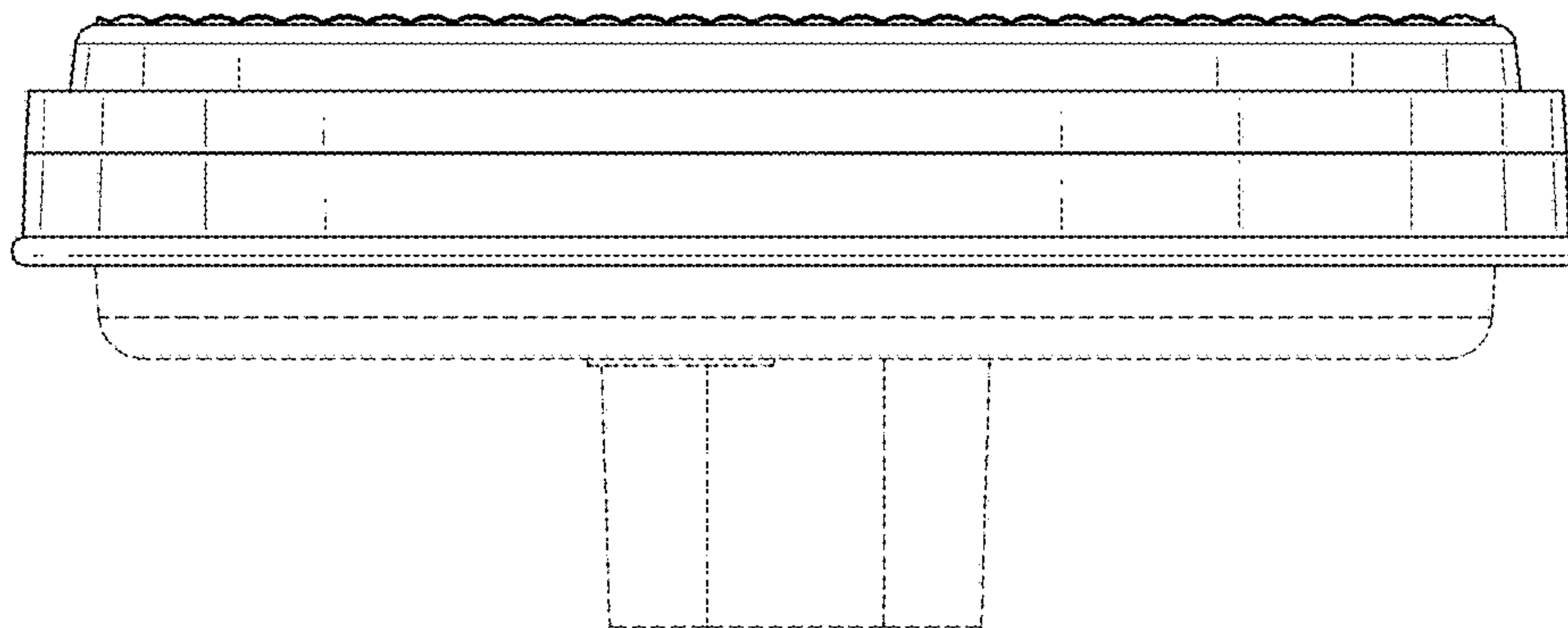

FIG. 3

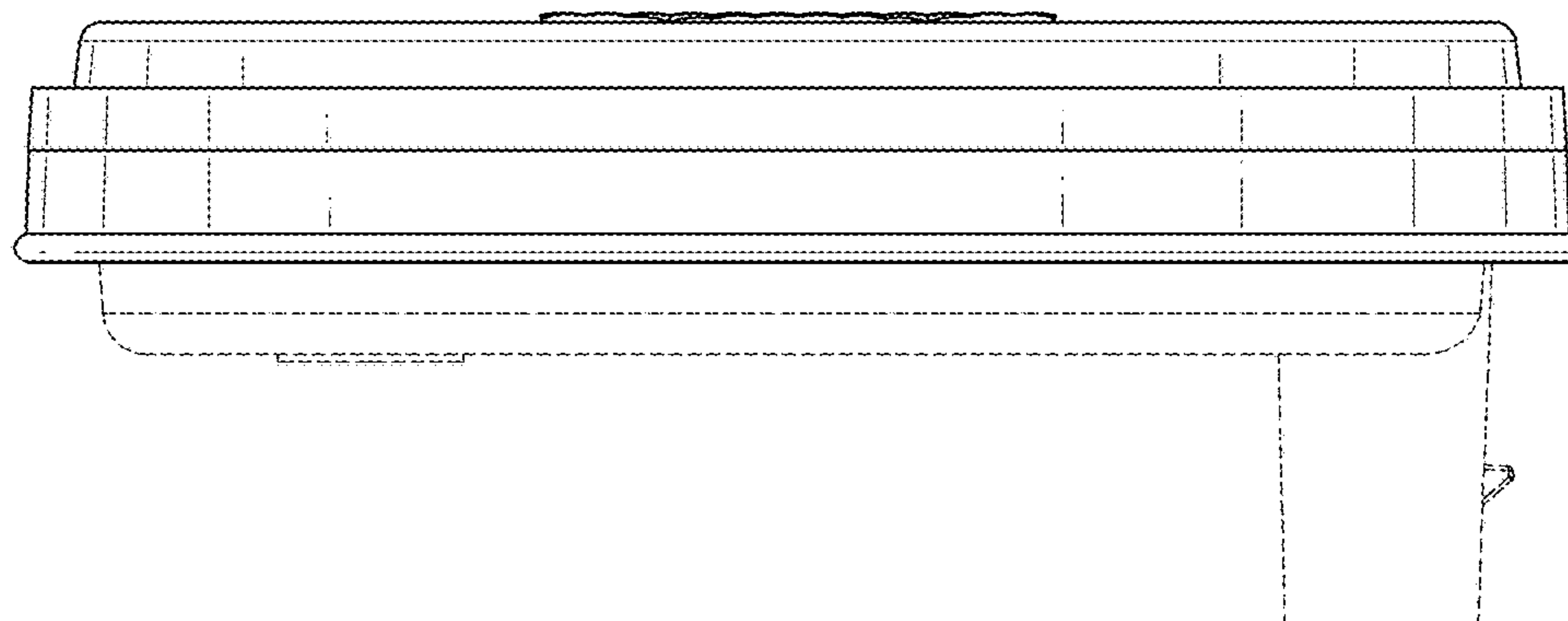

FIG. 4

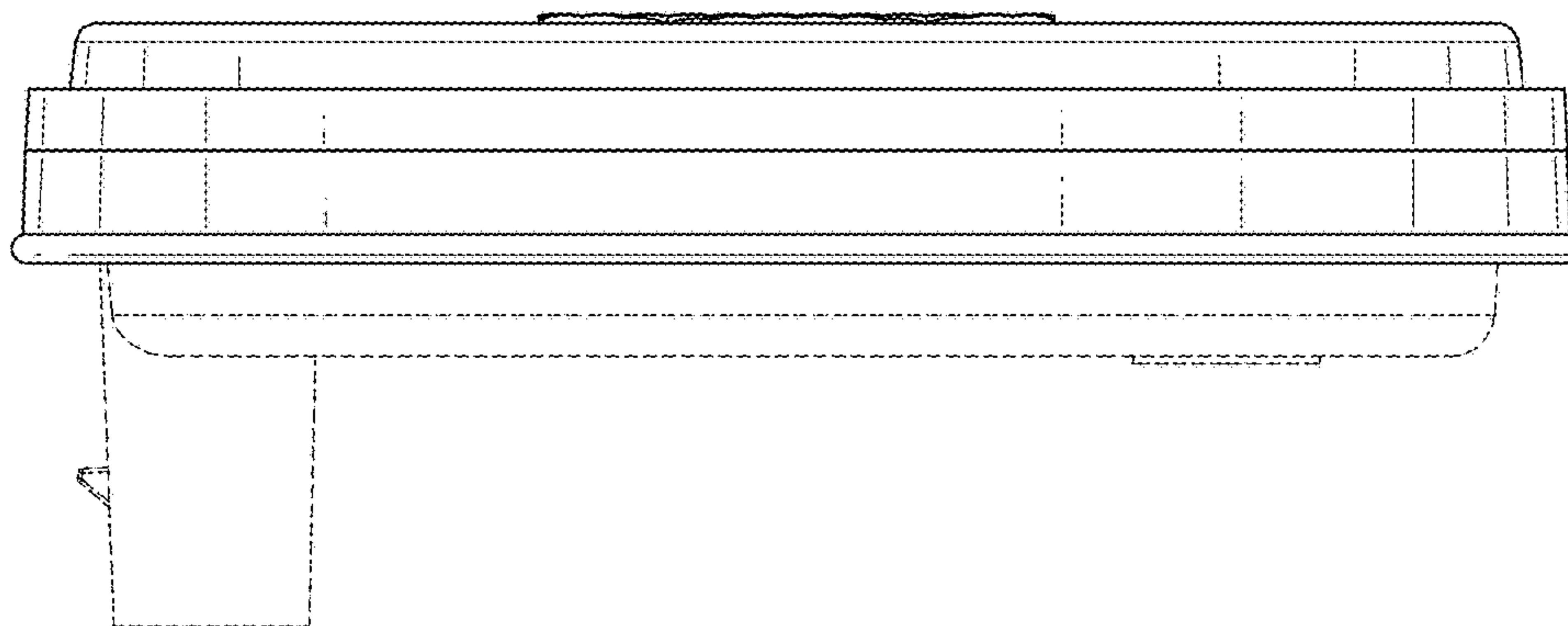

FIG. 5

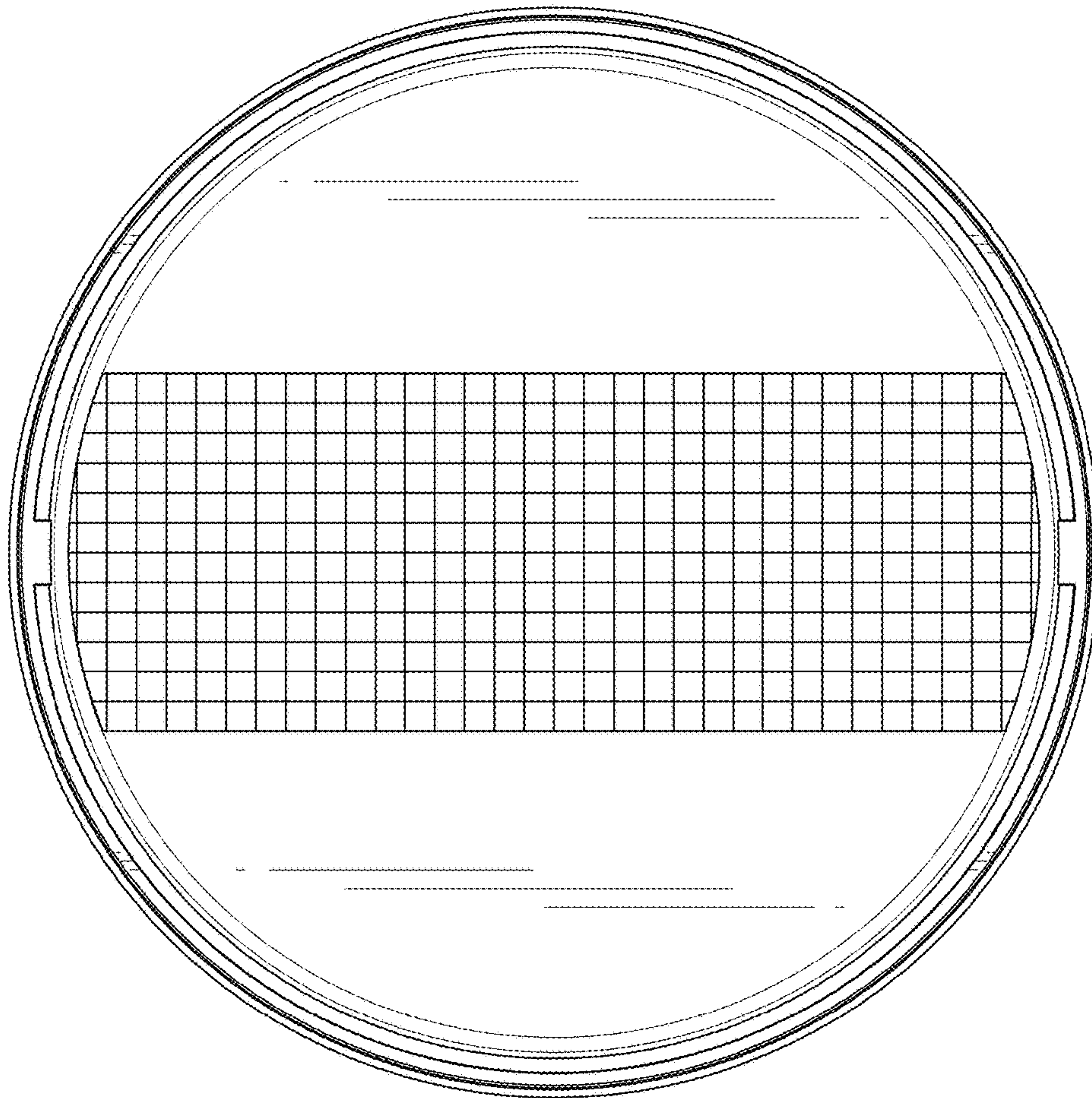

FIG.6

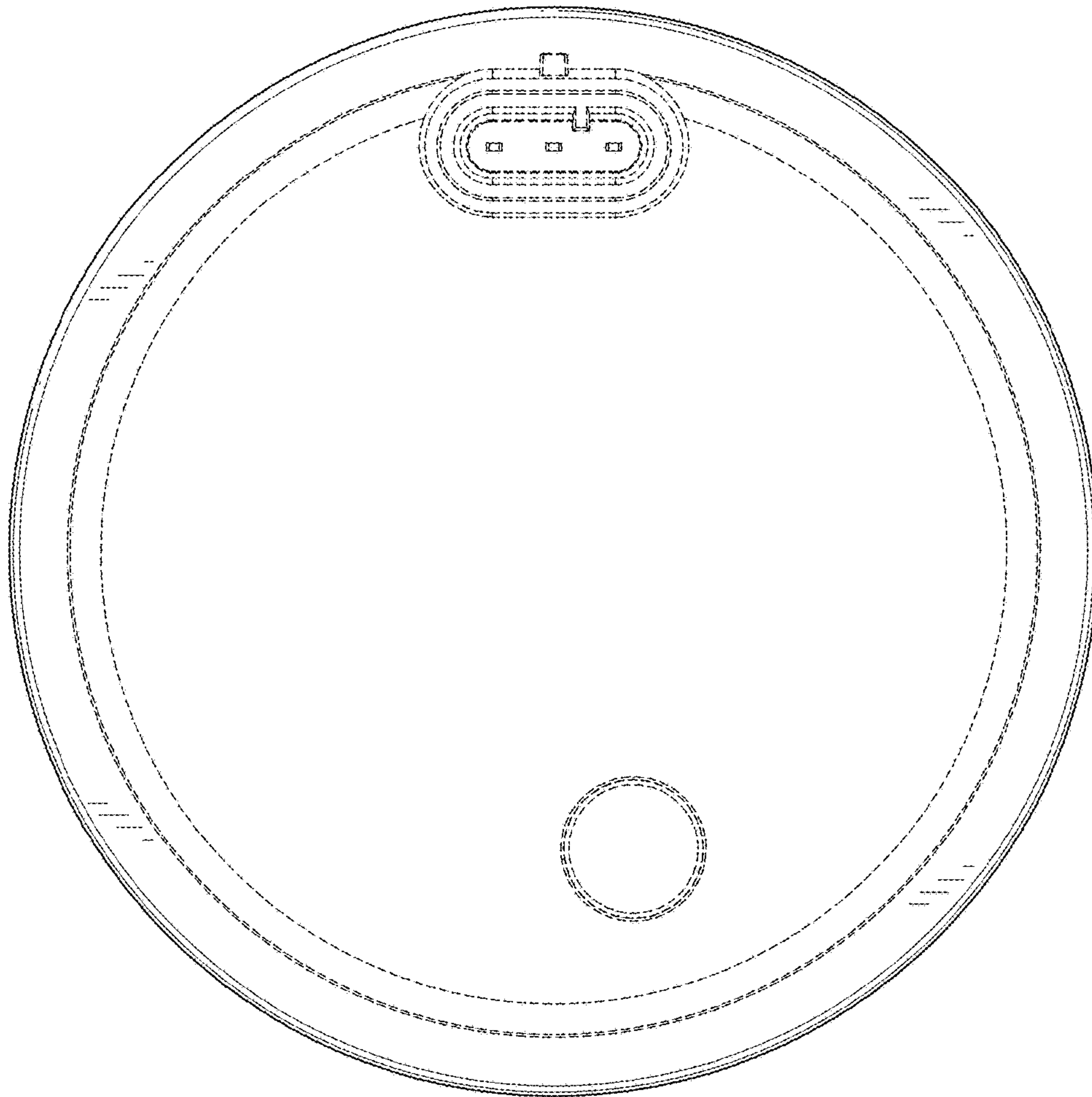

FIG.7