



US00D828796S

(12) **United States Design Patent**  
**Allmendinger et al.**

(10) **Patent No.:** **US D828,796 S**

(45) **Date of Patent:** **\*\* Sep. 18, 2018**

- (54) **WHEELIE BAR ASSEMBLY**
- (71) Applicant: **TRAXXAS LP**, McKinney, TX (US)
- (72) Inventors: **Otto Karl Allmendinger**, Rowlett, TX (US); **Adam Cole Ewing**, McKinney, TX (US)

- 5,330,221 A \* 7/1994 Sutton ..... B62H 1/12  
280/239
- 5,354,092 A \* 10/1994 Calvert ..... B60G 17/023  
267/242
- 5,368,323 A \* 11/1994 Young ..... B62H 1/12  
280/239

(Continued)

**FOREIGN PATENT DOCUMENTS**

- TW D135320 S 6/2010
- TW D139245 S 3/2011

**OTHER PUBLICATIONS**

Taiwan IPO Search Report; completed Oct. 16, 2017; in Taiwanese Design Patent Application No. 106302003.

(Continued)

*Primary Examiner* — Darlington Ly  
(74) *Attorney, Agent, or Firm* — Daryl R. Wright; Greg Carr

(57) **CLAIM**

We claim the ornamental design for a wheelie bar assembly for a model vehicle, as shown and described.

**DESCRIPTION**

FIG. 1 is a front elevation view of a wheelie bar assembly for a model vehicle;  
 FIG. 2 is a rear elevation view thereof;  
 FIG. 3 is a top plan view thereof;  
 FIG. 4 is a bottom plan view thereof;  
 FIG. 5 is a right side elevation view thereof, the left side elevation view being a mirror image thereof;  
 FIG. 6 is a top, front, and left side perspective view thereof; and  
 FIG. 7 is a top, rear, and right side perspective view thereof, when installed on the rear of an exemplary model vehicle. The broken line showing portions of the wheelie bar assembly and environmental structure of a model vehicle do not form part of the claimed design.

**1 Claim, 4 Drawing Sheets**

(73) Assignee: **Traxxas, LP**, McKinney, TX (US)

(\*\*) Term: **15 Years**

(21) Appl. No.: **29/581,532**

(22) Filed: **Oct. 19, 2016**

(51) **LOC (11) Cl.** ..... **12-16**

(52) **U.S. Cl.**  
USPC ..... **D12/171**

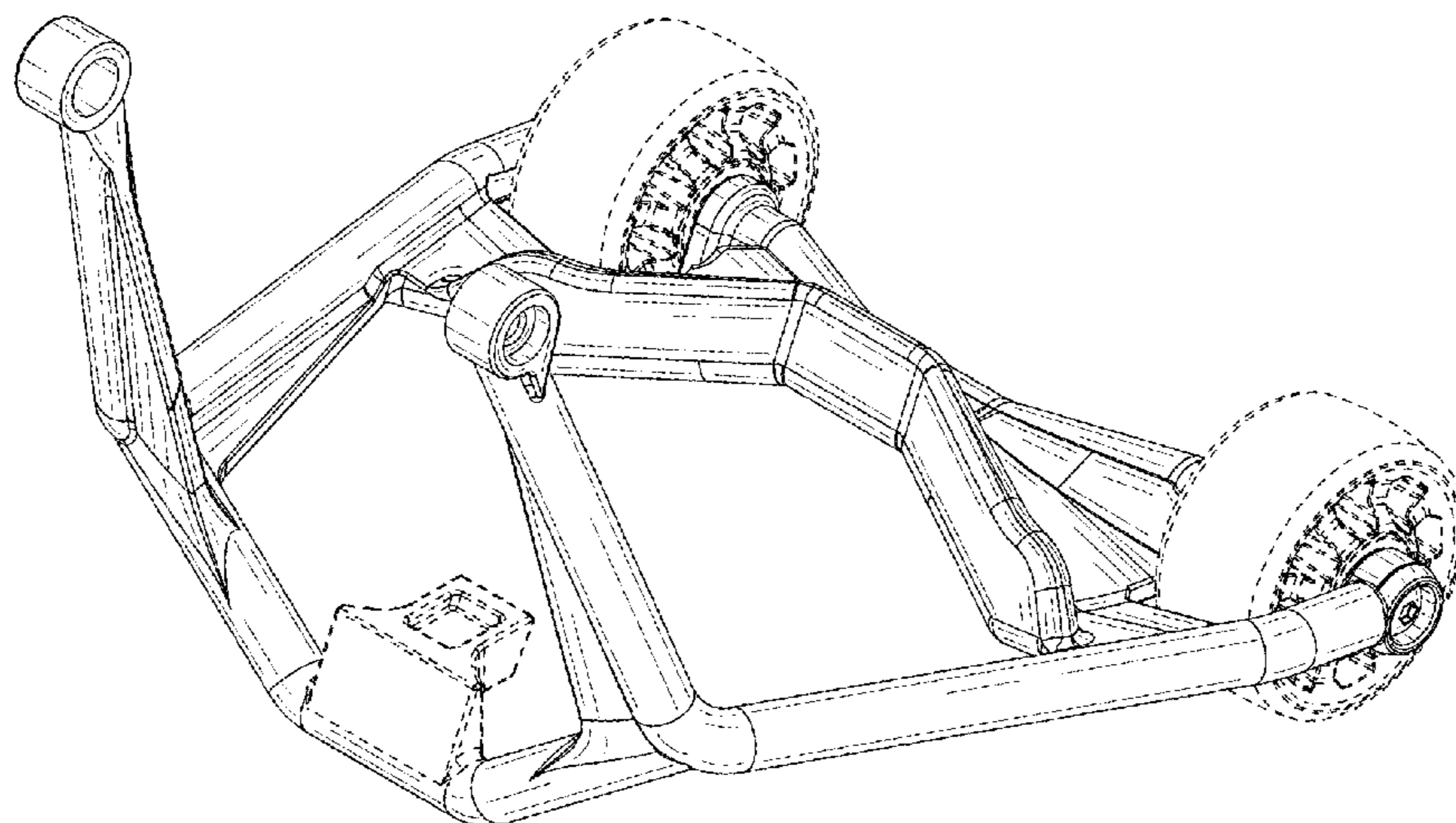
(58) **Field of Classification Search**  
 USPC ..... D12/86–92, 163–172  
 CPC ..... B60R 19/18; B60R 19/24; B60R 19/44;  
 B60R 19/48; B60R 19/56; B60R  
 2019/527; B60R 2019/1886; B62D  
 25/0845

See application file for complete search history.

(56) **References Cited**

**U.S. PATENT DOCUMENTS**

- 3,997,185 A \* 12/1976 Parrilla ..... B62J 27/00  
280/239
- 4,007,949 A \* 2/1977 Norcia ..... B60B 15/00  
267/48
- 4,108,267 A \* 8/1978 Valerio ..... B60G 9/00  
180/345
- 4,154,452 A \* 5/1979 Newman ..... B62J 27/00  
280/1.189
- 4,773,889 A 9/1988 Rosenwinkel et al.
- 4,988,120 A \* 1/1991 Jones ..... B60G 5/00  
180/271
- 5,186,269 A 2/1993 Avakian et al.



(56)

References Cited

U.S. PATENT DOCUMENTS

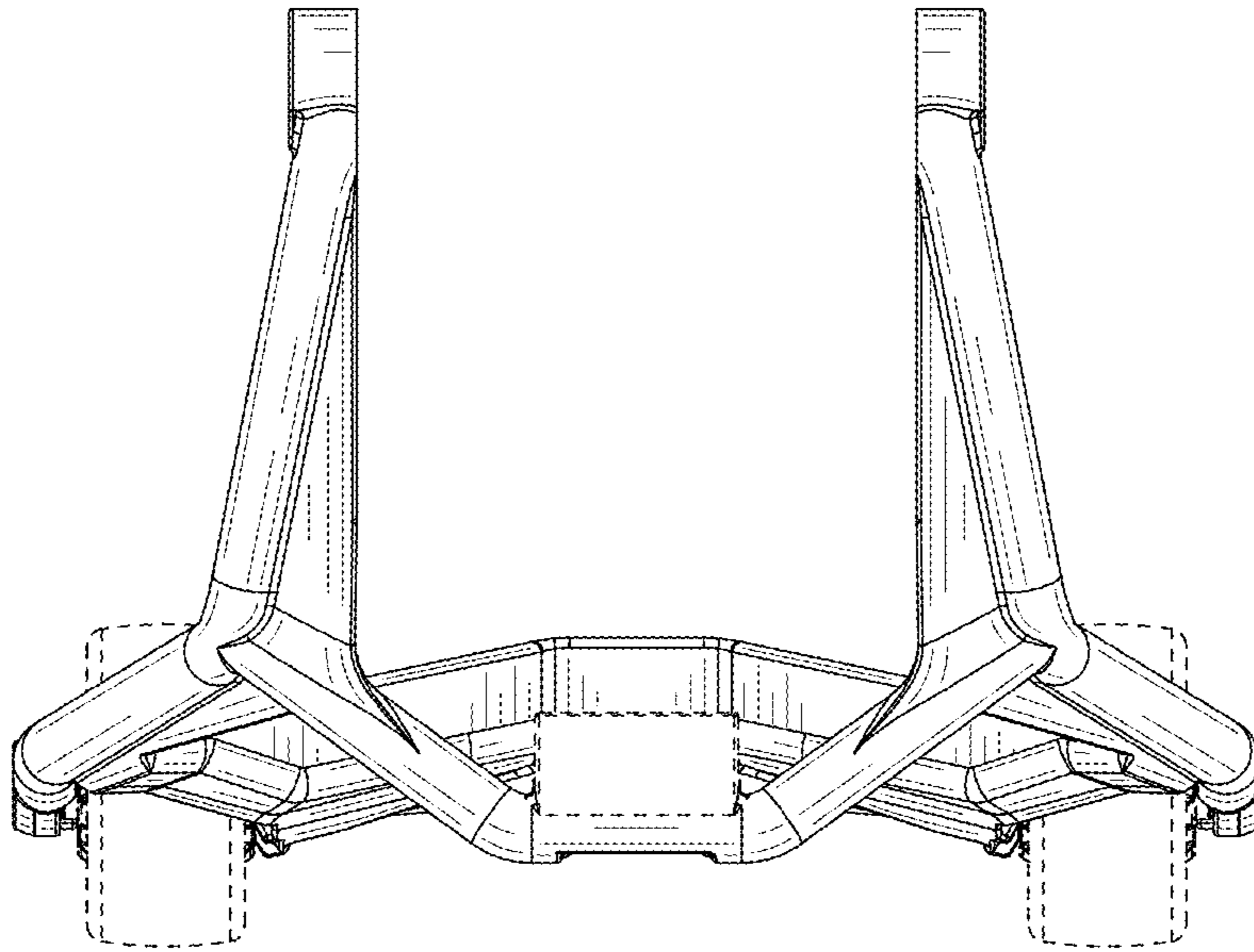
5,431,444 A \* 7/1995 Kenealy ..... A01D 34/001  
180/19.1  
D366,636 S \* 1/1996 Smith ..... D12/114  
D394,003 S 5/1998 Tate  
D394,033 S \* 5/1998 Pingel ..... D12/114  
5,809,755 A 9/1998 Velke et al.  
5,908,345 A 6/1999 Choi  
5,938,238 A \* 8/1999 Lamb ..... B60G 7/003  
280/5.513  
6,059,055 A 5/2000 Velke et al.  
6,094,897 A 8/2000 Velke et al.  
6,189,304 B1 2/2001 Velke et al.  
6,327,839 B1 12/2001 Velke et al.  
6,416,067 B1 \* 7/2002 Kugler ..... B60G 7/003  
280/104  
6,516,596 B2 2/2003 Velke et al.  
6,517,092 B2 2/2003 Humphrey  
6,540,583 B1 \* 4/2003 Hoeting ..... A63H 17/004  
446/431  
6,688,090 B2 2/2004 Velke et al.  
6,912,831 B2 7/2005 Velke et al.  
6,994,368 B2 \* 2/2006 Brown ..... B62H 1/12  
280/288.4  
7,048,285 B1 \* 5/2006 Yates ..... B60G 3/14  
280/124.104  
D546,751 S 7/2007 Laatz  
D567,886 S 4/2008 Lampert et al.  
7,578,721 B1 \* 8/2009 Allmendinger ..... A63H 17/16  
446/431  
8,075,011 B1 \* 12/2011 Duzzny ..... B62H 7/00  
280/288.4  
8,590,909 B2 \* 11/2013 Calvert ..... B60G 5/00  
280/124.104  
D771,537 S \* 11/2016 Hare ..... D12/169  
D777,619 S \* 1/2017 Barajas ..... D12/167  
D785,504 S \* 5/2017 Higgs ..... D12/91  
2001/0014569 A1 \* 8/2001 Baker ..... A63G 25/00  
446/448

2002/0096849 A1 \* 7/2002 Bang ..... A63C 17/26  
280/87.041  
2003/0024752 A1 \* 2/2003 Mayer ..... B62K 3/002  
180/220  
2003/0077979 A1 4/2003 Hoeting et al.

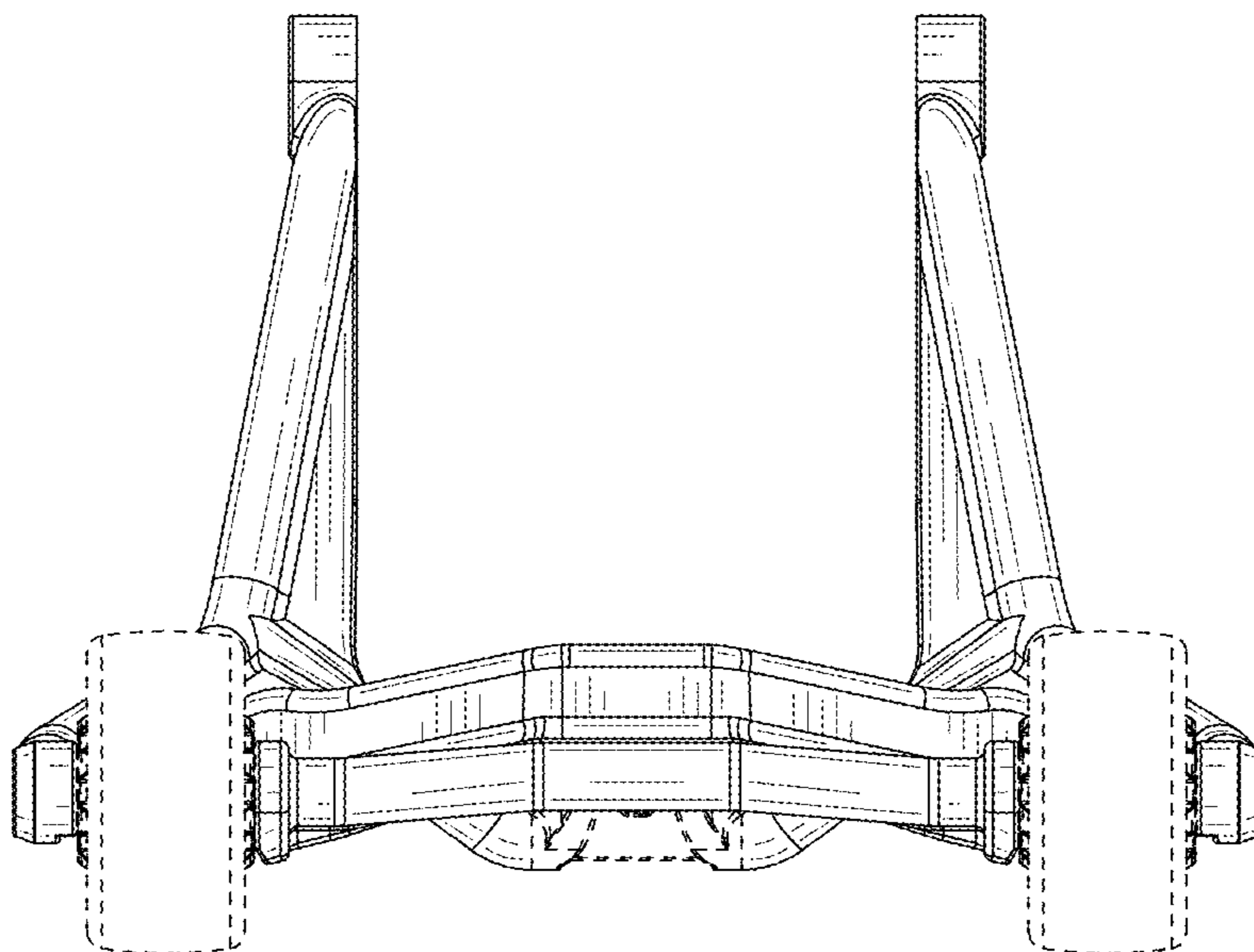
OTHER PUBLICATIONS

Traxxas; Wheelie Bar, Overview; Aug. 2011; www.traxxas.com/products/parts/5472.  
HPI Racing; Wheelie Bar Set for Savage #85245; Jun. 2016; www.hpiracing.com/en/part/85245.  
HPI, "Savage Wheelie Bar" Oct. 19, 2005, web page: www.hpiracing.com/products/en/85245/HPI Racing, Foothill Ranch, CA, USA.  
New Era Models "Wheelie Bar" Dec. 15, 2005, web page: http://www.rchobbies.net/index.php?main\_page=product\_info&products\_id=3415.  
Tork n Dork, "Wheelie Bar" Sep. 8, 2005, web page: www.torkndork.com/wheeliebar.html Tork n Dork, Quebec, CA.  
Traxxas, "ESP Rear Bumper with Wheelie Bar T/E Maxx" Dec. 16, 2005 web page: http://www3.towerhobbies.com/cgi-bin/wti0001p?&I=LXXA00&P=ML Traxxas LP, Plano, TX USA.  
Traxxas, "Ultimate Maxx Wheelie Bar", Dec. 16, 2005, web page: http://www.rlhobbies.com/cart/prod\_detail.php?prodid=PCI0100 Traxxas LP, Plano, TX, USA.  
Trinity, "Wheelie Bar Set T/E Maxx", Dec. 16, 2005, web page: http://www3.towerhobbies.com/cgi-bin/wti0001p?&I=LXZH42&P=7 Trinity, Piscataway, NJ, USA.  
Unknown, Wheelie Bar Apparatus, Dec. 16, 2005, web page: www.RLhobbies.com; 2 photographs (admitted prior art).  
Unknown, Wheelie Bar Apparatus, Dec. 16, 2005, web page: www.RLhobbies.com; 1 photograph (admitted prior art).  
Unknown, Wheelie Bar Apparatus, Sep. 8, 2005, 3 photographs (admitted prior art).  
Unknown, Wheelie Bar Apparatus, Sep. 8, 2005, 1 photograph (admitted prior art).

\* cited by examiner

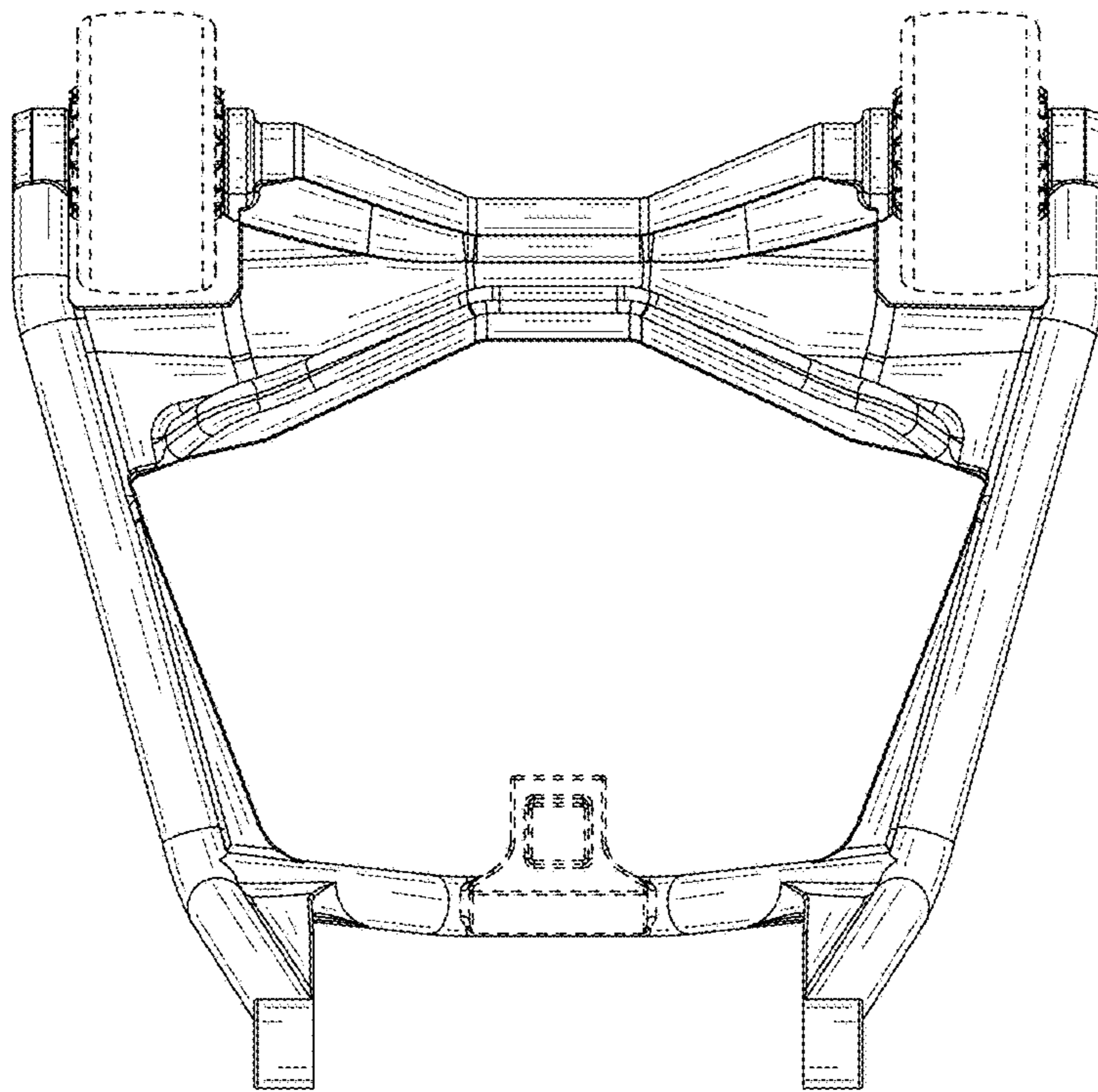


**FIG. 1**

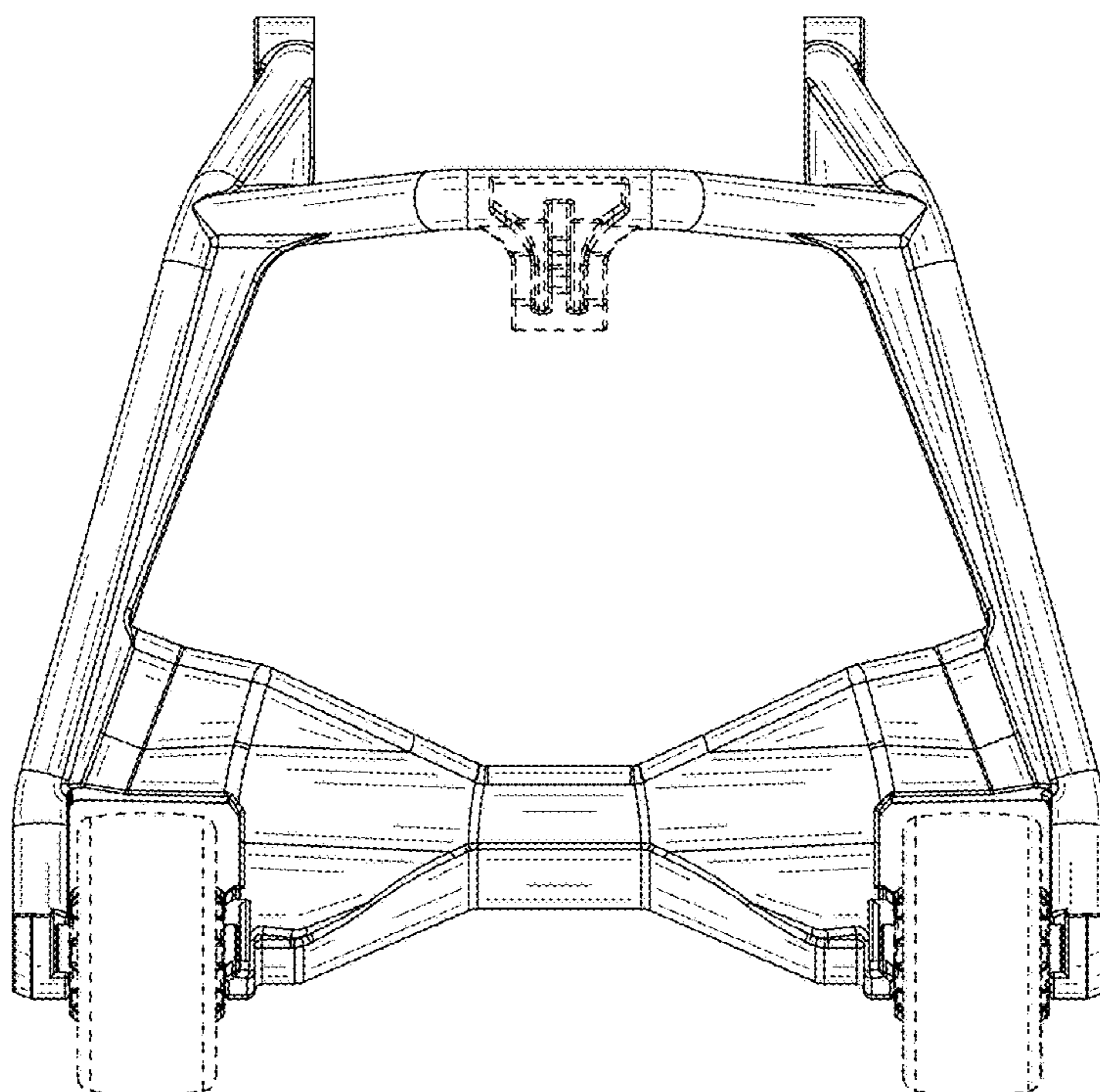


**FIG. 2**

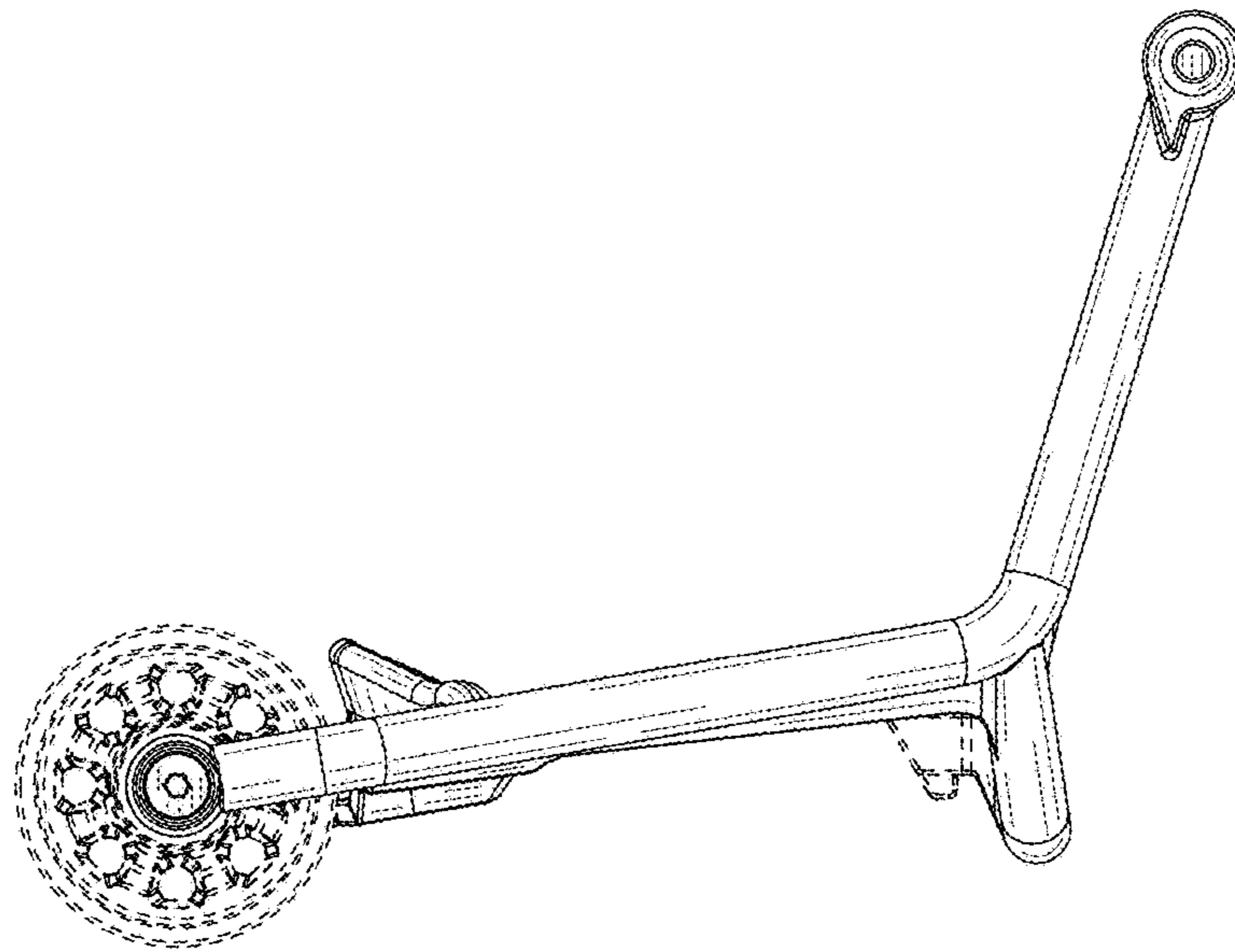




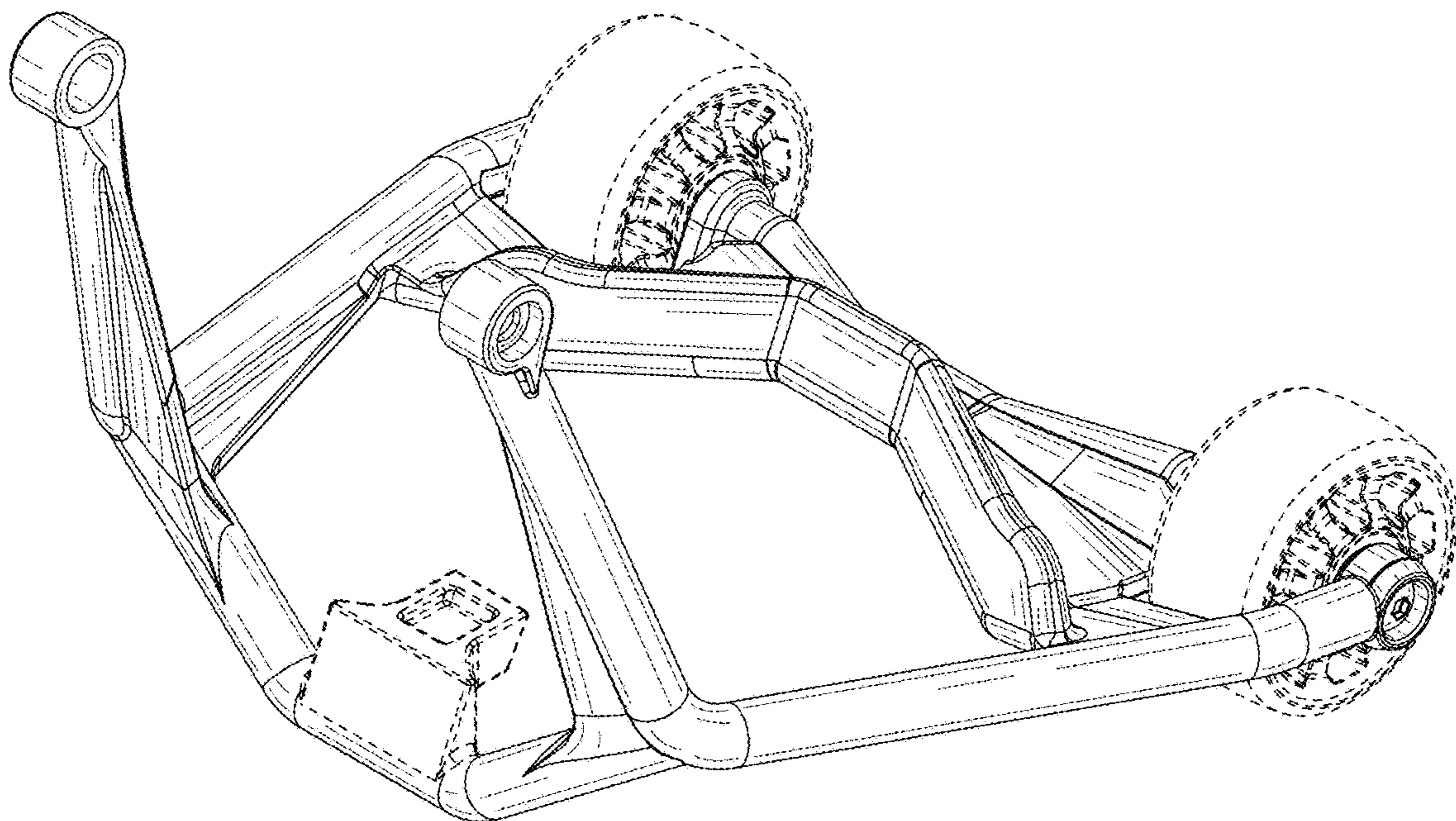
**FIG. 3**



**FIG. 4**



**FIG. 5**



**FIG. 6**



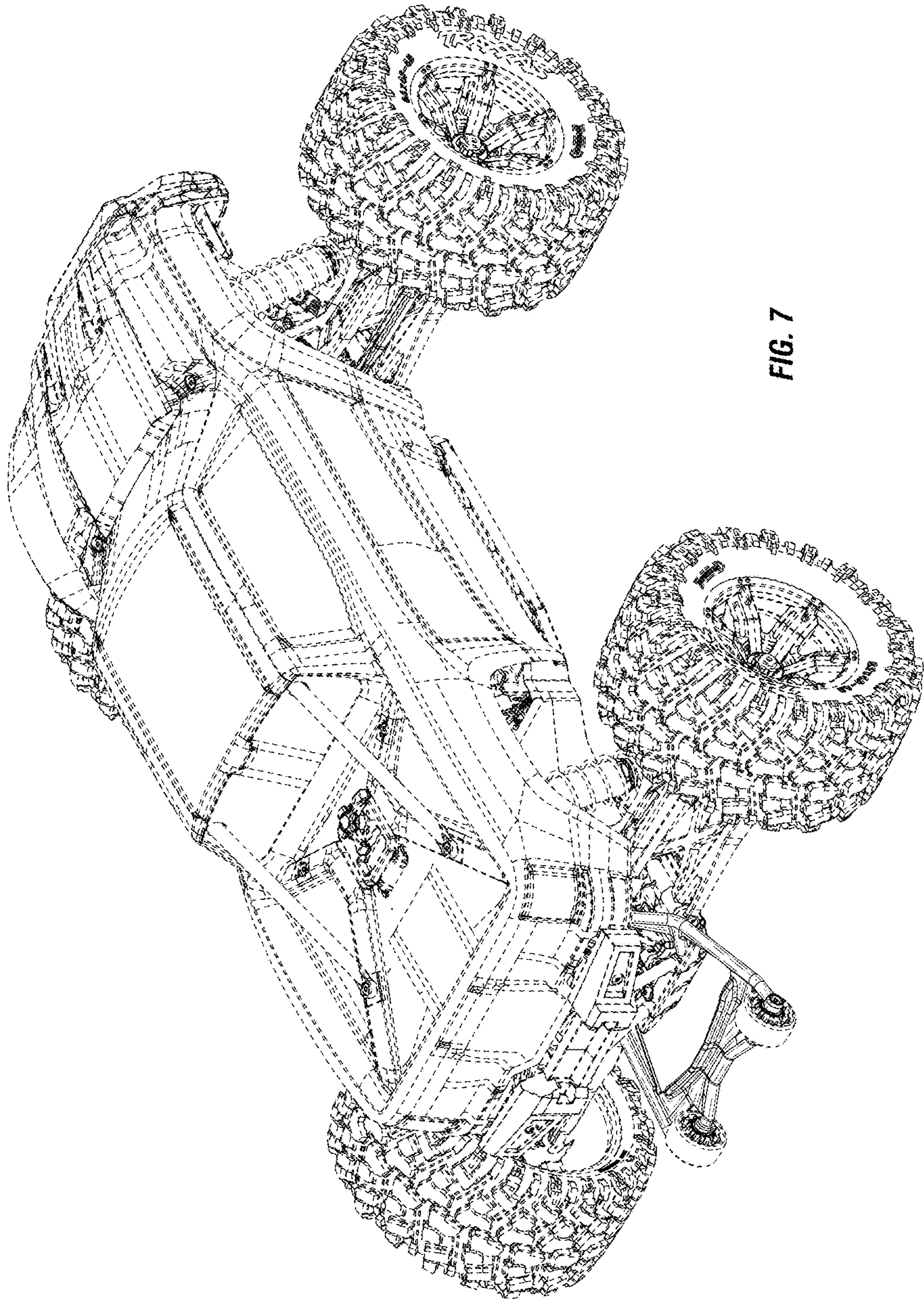


FIG. 7