



US00D828770S

(12) **United States Design Patent** (10) **Patent No.:** **US D828,770 S**  
**Mandokoro** (45) **Date of Patent:** **\*\* Sep. 18, 2018**

(54) **MAGNETISM DETECTING SENSOR**

(71) Applicant: **SMC CORPORATION**, Tokyo (JP)

(72) Inventor: **Jiro Mandokoro**, Moriya (JP)

(73) Assignee: **SMC CORPORATION**, Tokyo (JP)

(\*\*) Term: **15 Years**

(21) Appl. No.: **29/566,315**

(22) Filed: **May 27, 2016**

(30) **Foreign Application Priority Data**

Nov. 30, 2015 (CN) ..... 2015 3 0490791

(51) **LOC (11) Cl.** ..... **10-04**

(52) **U.S. Cl.**  
USPC ..... **D10/49**

(58) **Field of Classification Search**  
USPC ..... D10/46, 49, 70, 79, 80, 100, 104.1, 121;  
D15/199  
CPC ..... F15B 15/28; F15B 15/2861; G01D 5/22;  
G01D 5/225; G01D 5/2258  
See application file for complete search history.

(56) **References Cited**

**U.S. PATENT DOCUMENTS**

3,991,393 A \* 11/1976 Becker, Jr. .... F15B 15/28  
336/30  
D752,999 S \* 4/2016 Takenaka ..... D10/106.1  
D753,519 S \* 4/2016 Takenaka ..... D10/106.1

(Continued)

**FOREIGN PATENT DOCUMENTS**

DE 102005015948 A1 \* 10/2006 ..... F15B 15/28  
JP D877752/2 S 1/2000

(Continued)

**OTHER PUBLICATIONS**

SMC Solid State Pneumatic Position Detector, IP67, posted on rs-online.com, no posted date given, no production date given,

[online], [site visited Aug. 4, 2017], Available from Internet, URL: <http://ph.rs-online.com/web/p/pneumatic-cylinder-actuator-sensors/8497109/>.\*

(Continued)

*Primary Examiner* — Melanie H Tung  
*Assistant Examiner* — Fritzgerald L Butac

(74) *Attorney, Agent, or Firm* — Birch, Stewart, Kolasch & Birch, LLP

(57) **CLAIM**

The ornamental design for a magnetism detecting sensor, as shown.

**DESCRIPTION**

FIG. 1 is a rear, top and left side perspective view of a magnetism detecting sensor showing a first embodiment of my new design;  
FIG. 2 is a front, bottom and right side perspective view thereof;  
FIG. 3 is a front view thereof;  
FIG. 4 is a rear view thereof;  
FIG. 5 is a top plan view thereof;  
FIG. 6 is a bottom plan view thereof;  
FIG. 7 is a left side view thereof;  
FIG. 8 is a right side view thereof;  
FIG. 9 is a rear, top and left side perspective view of a magnetism detecting sensor showing a second embodiment of my new design;  
FIG. 10 is a front, bottom and right side perspective view of FIG. 9;  
FIG. 11 is a front view of FIG. 9;  
FIG. 12 is a rear view of FIG. 9;  
FIG. 13 is a top plan view of FIG. 9;  
FIG. 14 is a bottom plan view of FIG. 9;  
FIG. 15 is a left side view of FIG. 9; and,  
FIG. 16 is a right side view of FIG. 9.

**1 Claim, 16 Drawing Sheets**

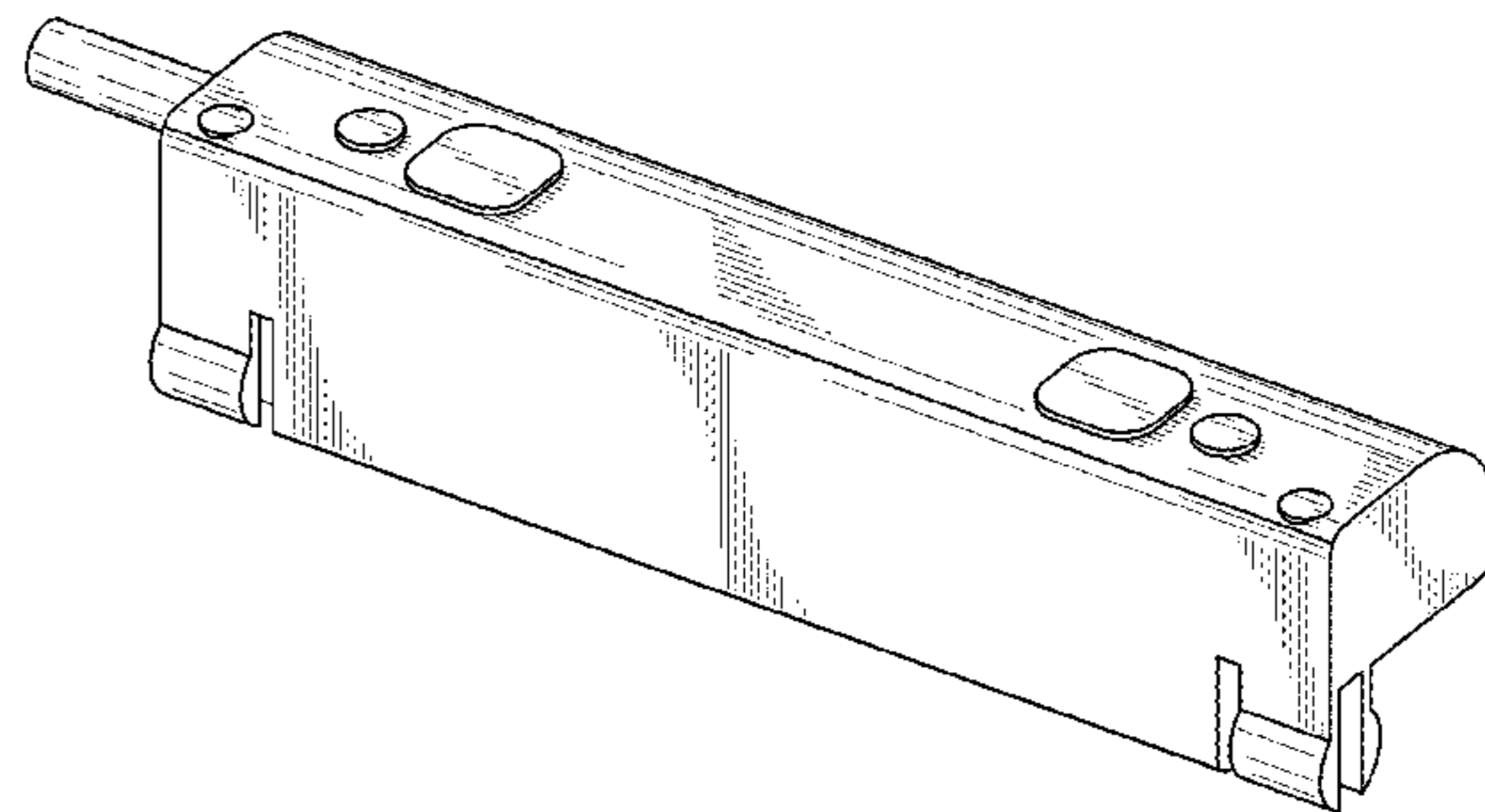
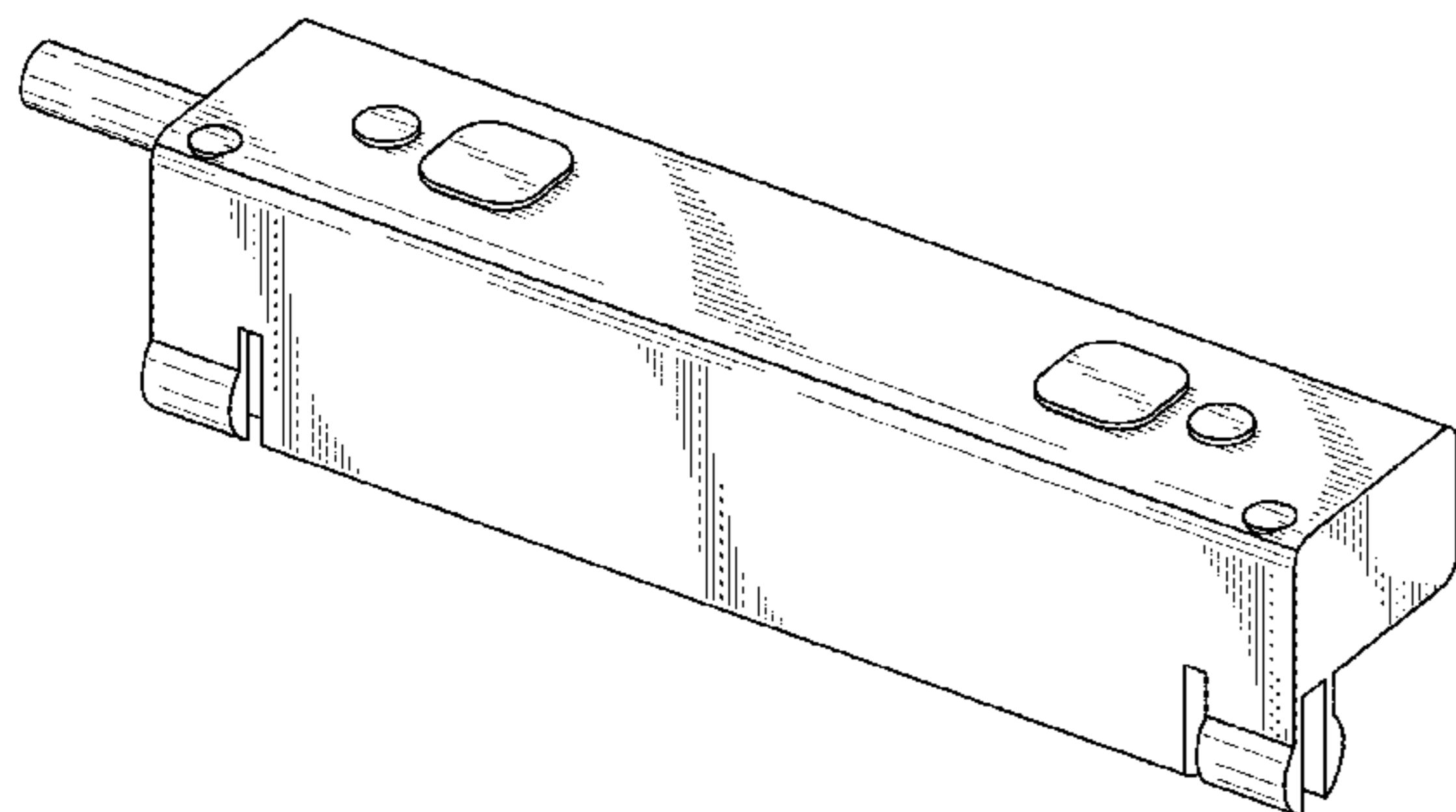

(56)

**References Cited**

U.S. PATENT DOCUMENTS

D769,745 S \* 10/2016 Takenaka ..... D10/70  
 2003/0042892 A1\* 3/2003 Nagai ..... F15B 15/2807  
 324/207.11  
 2015/0316396 A1\* 11/2015 Mandokoro ..... F15B 15/2892  
 73/431

FOREIGN PATENT DOCUMENTS

JP D1097985 S 1/2001  
 JP 2003156305 A \* 5/2003 ..... F15B 15/2892  
 JP D1430993 S 1/2012  
 JP 2012132500 A \* 7/2012 ..... F15B 15/28  
 WO WO-2012086361 A1 \* 6/2012 ..... F16B 15/28  
 WO WO-2016167035 A1 \* 10/2016 ..... F16B 2/08

OTHER PUBLICATIONS

Auto switch SMC D-M9N D-M9 Series, posted on rs-online.com, no posted date given, no production date given, [online], [site visited Aug. 4, 2017], Available from Internet, URL: <http://jp.rs-online.com/web/p/pneumatic-cylinder-actuator-switches/0576106/>.\*

Solid state auto switch, posted on hirasawa-syoji.co.jp, no posted date given, production end date Apr. 2004, [online], [site visited Aug. 4, 2017], Available from Internet, URL: <http://www.hirasawa-syoji.co.jp/maker/smc/syuryo/I09-11.htm>.\*

CDQ2P, Compact Cylinder, High Magnetic Field Design, posted on smcusa.com, no posted date given, no production date given, [online], [site visited Aug. 4, 2017], Available from Internet, URL: <http://www.smcusa.com/products/CDQ2-P-Compact-Cylinder-High-Magnetic-Field-Design~133670>.\*

\* cited by examiner

FIG. 1

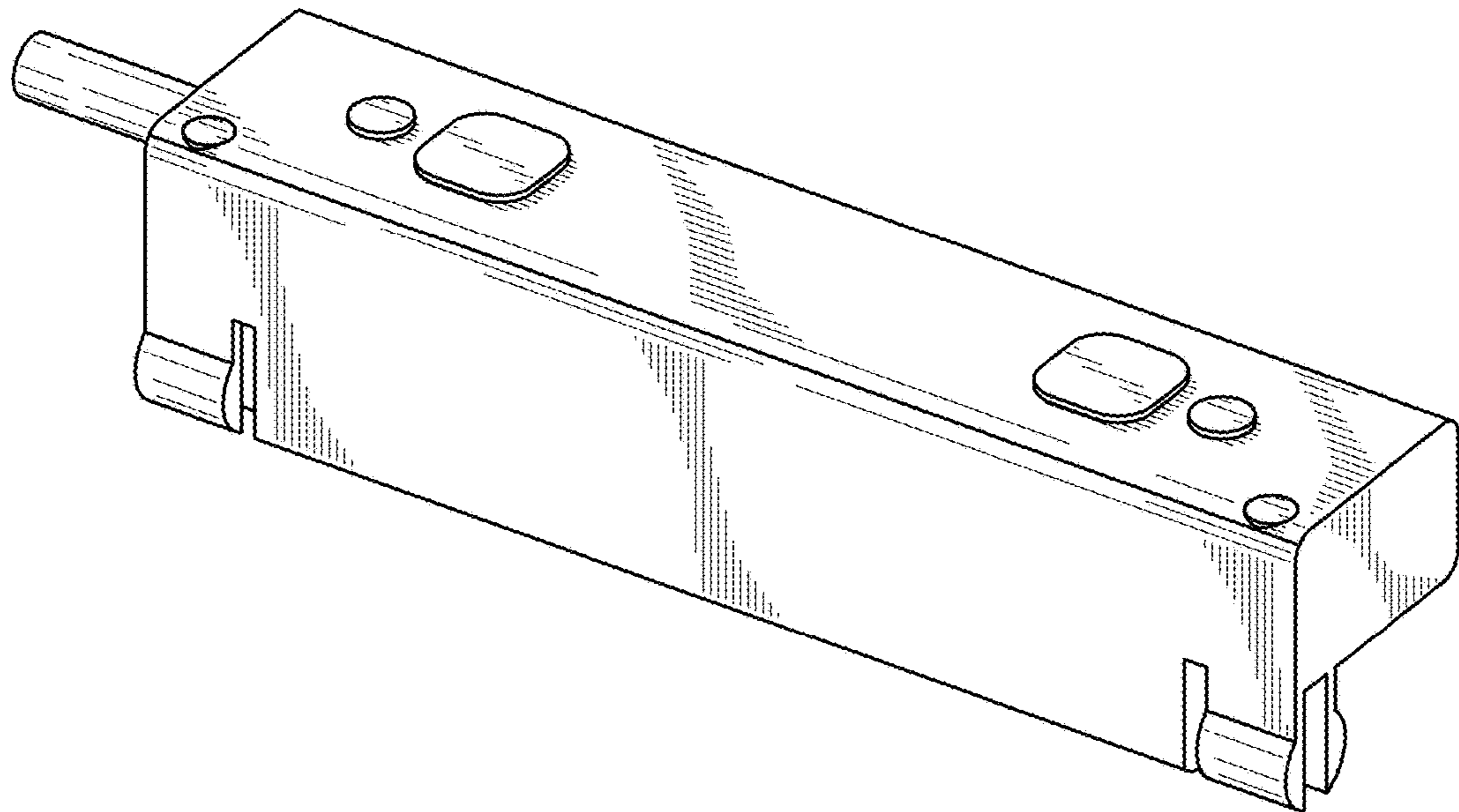

FIG. 2

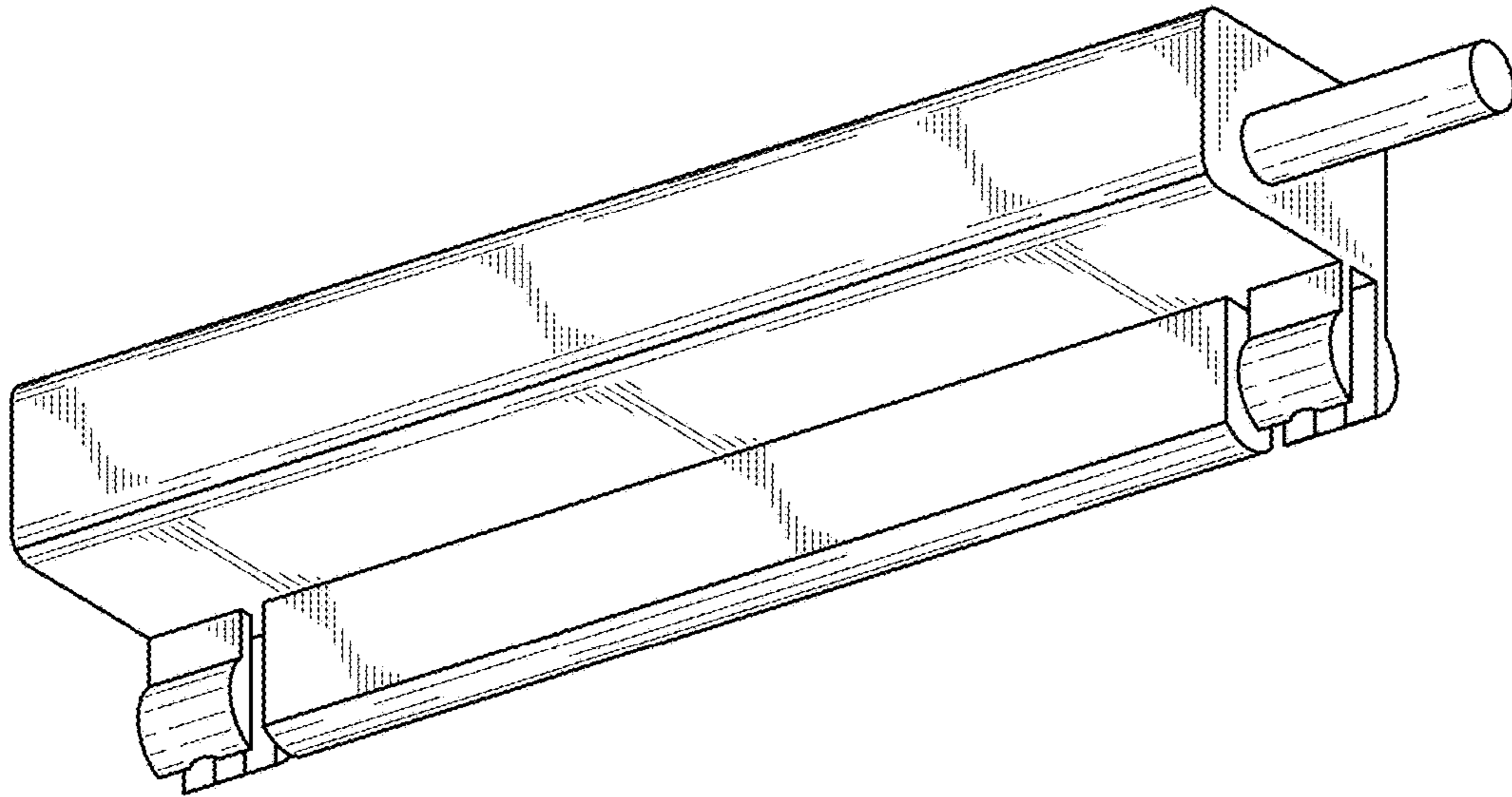

FIG. 3

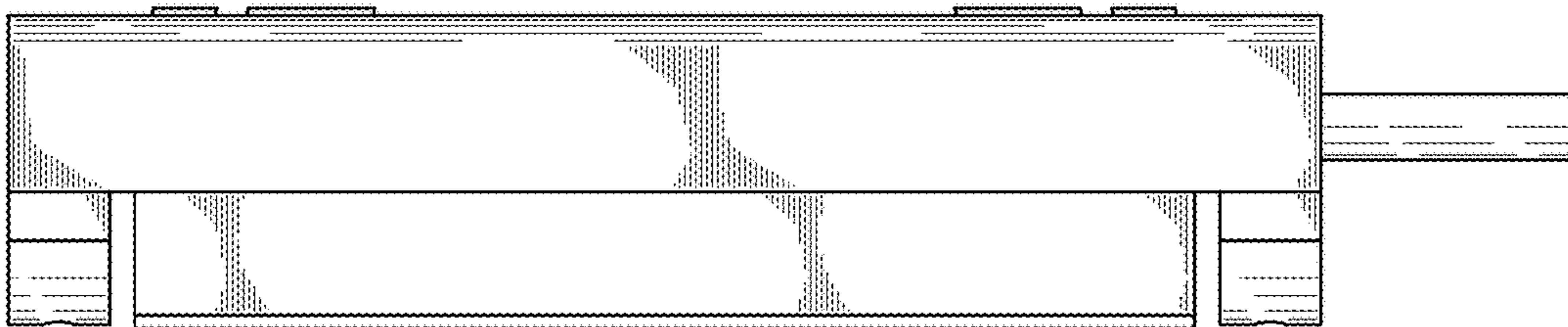

FIG. 4

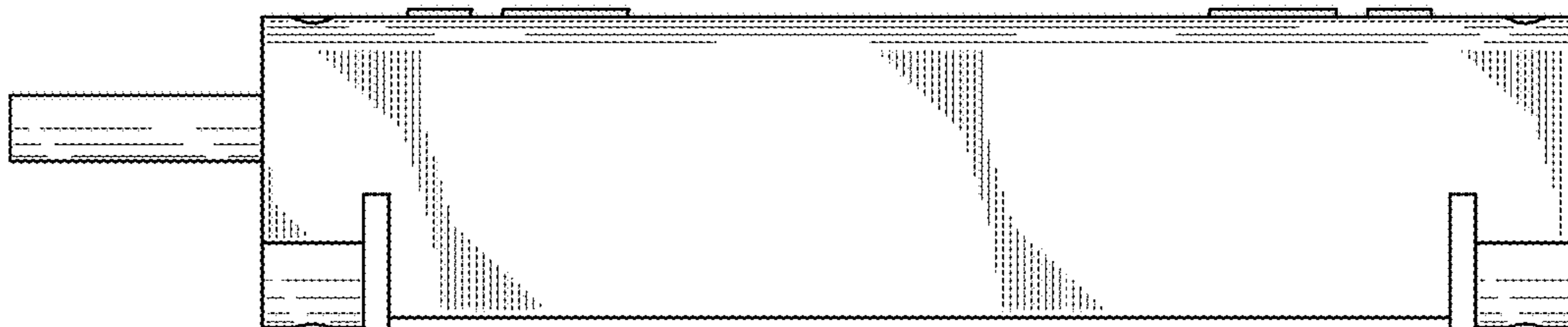

FIG. 5

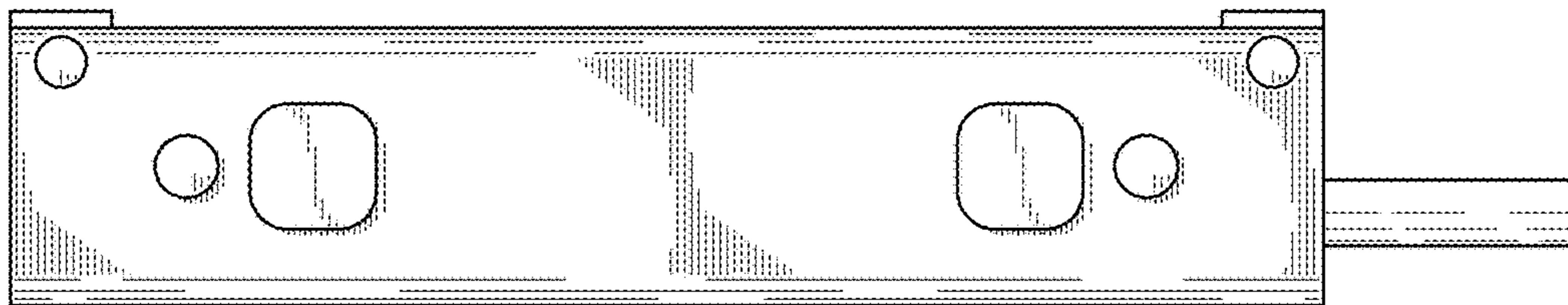

FIG. 6

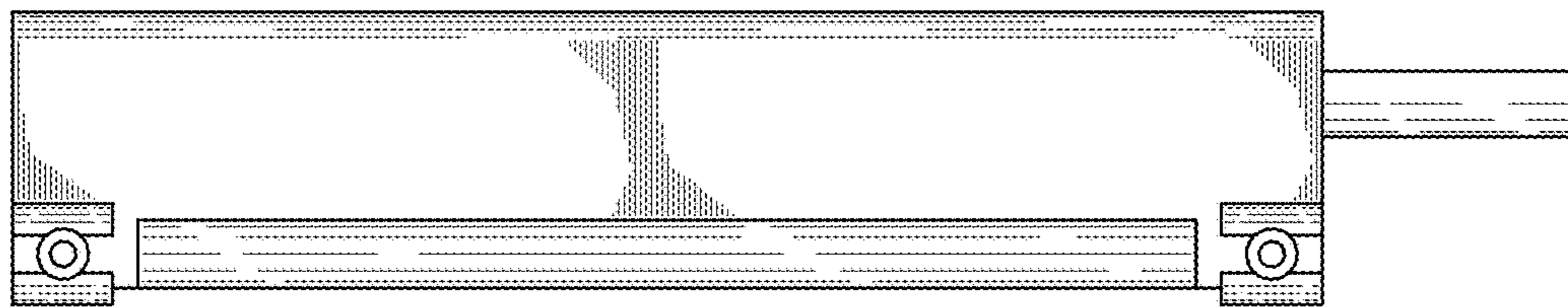



FIG. 7

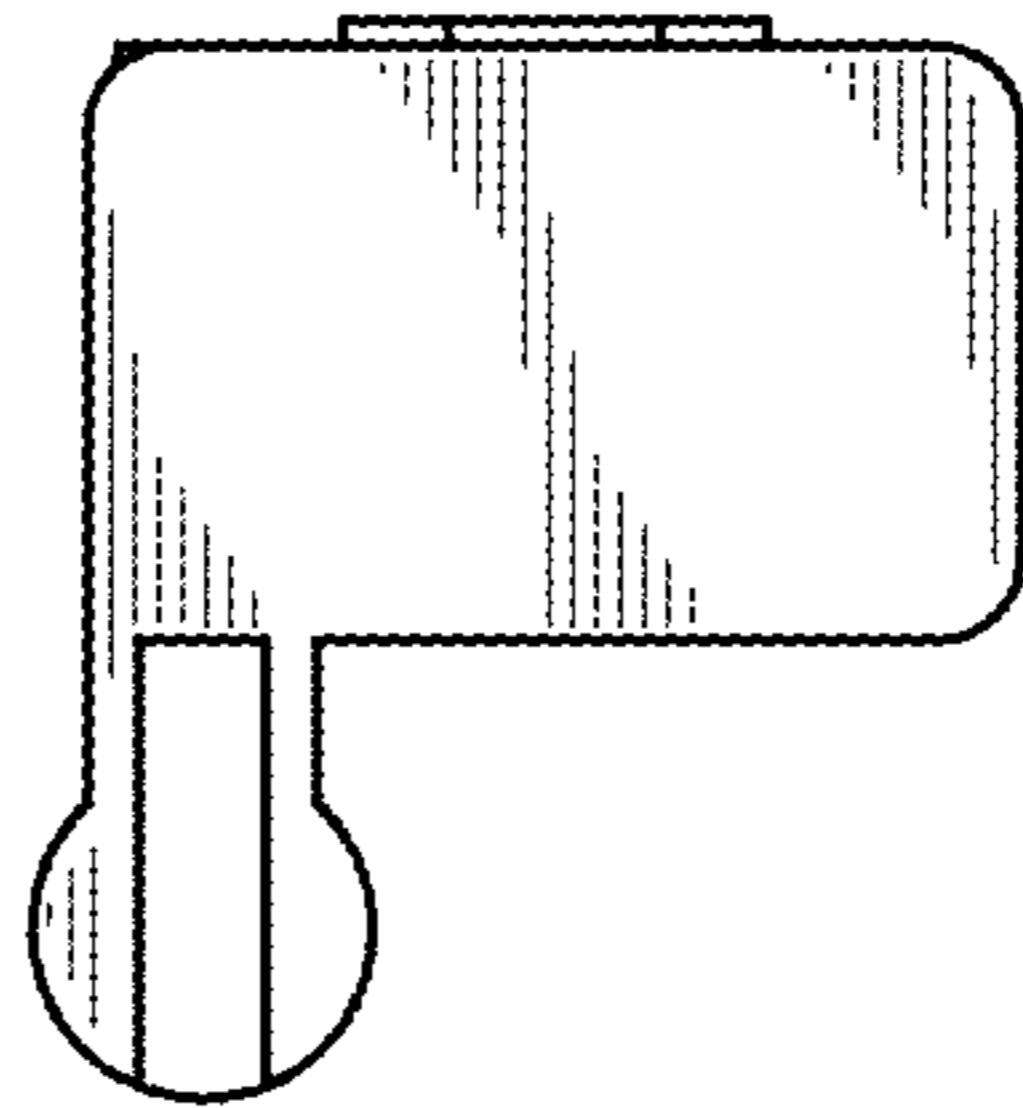

FIG. 8

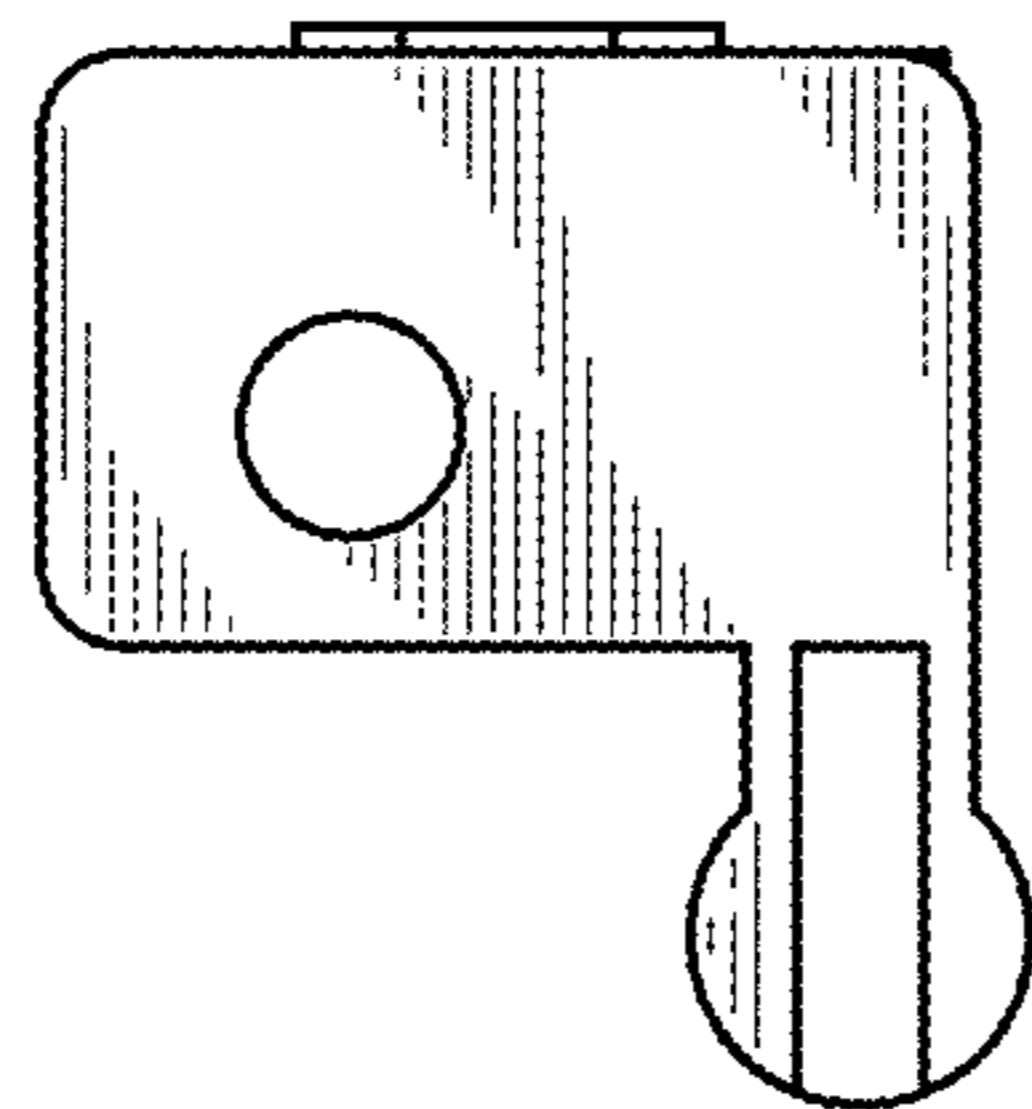

FIG. 9

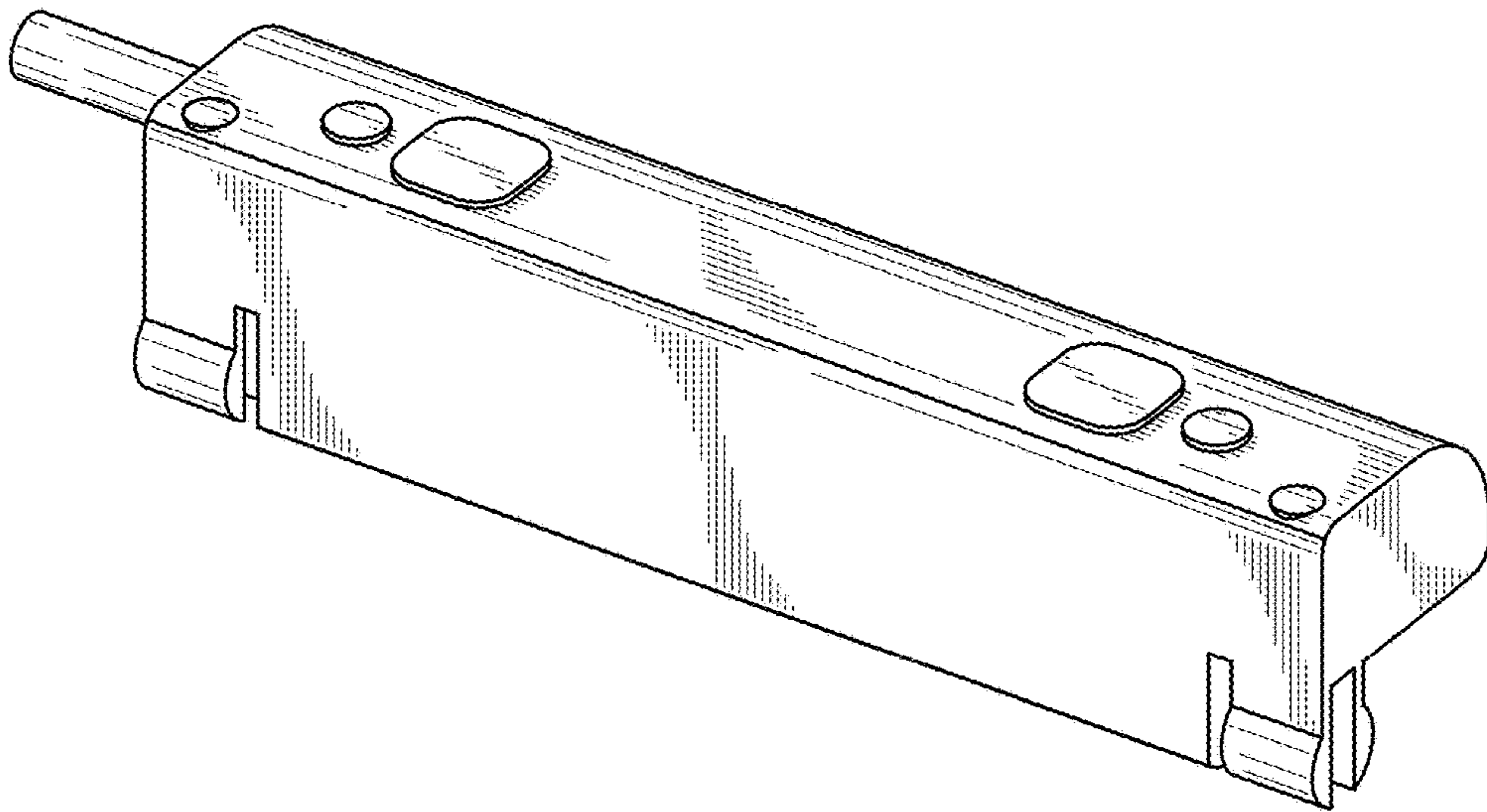

FIG. 10

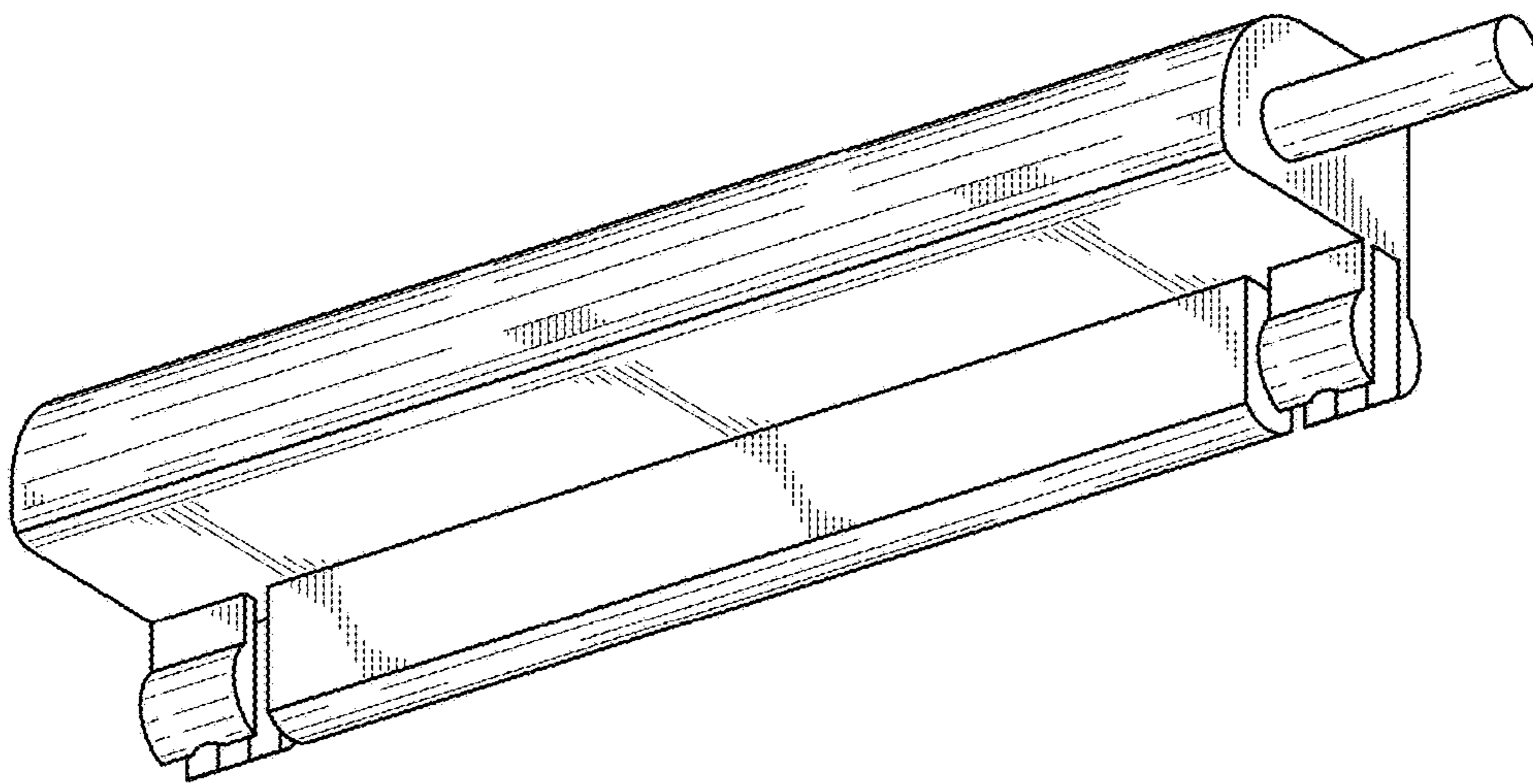

FIG. 11

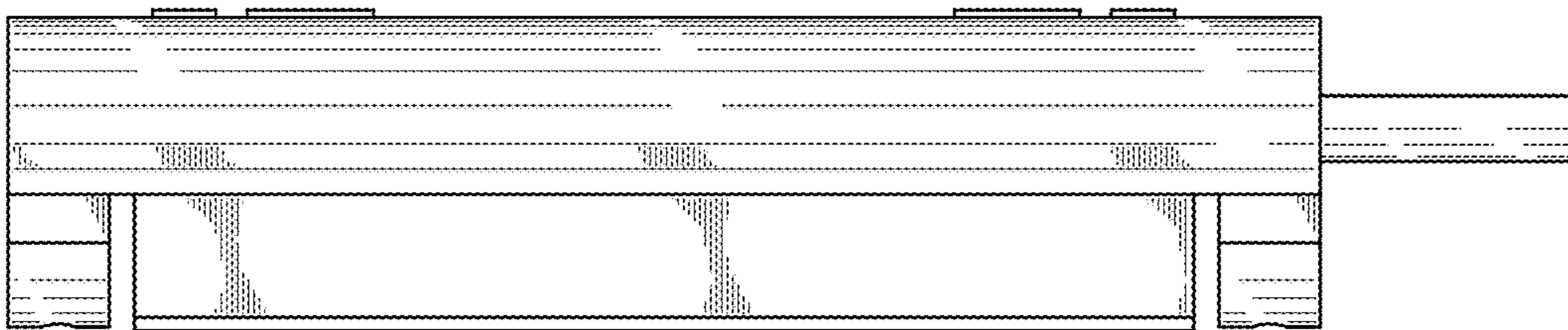

FIG. 12

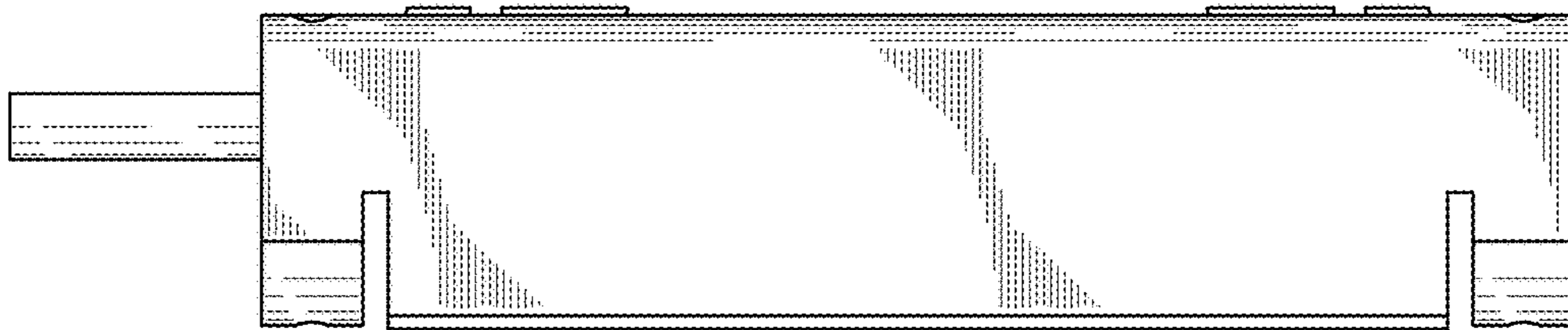

FIG. 13

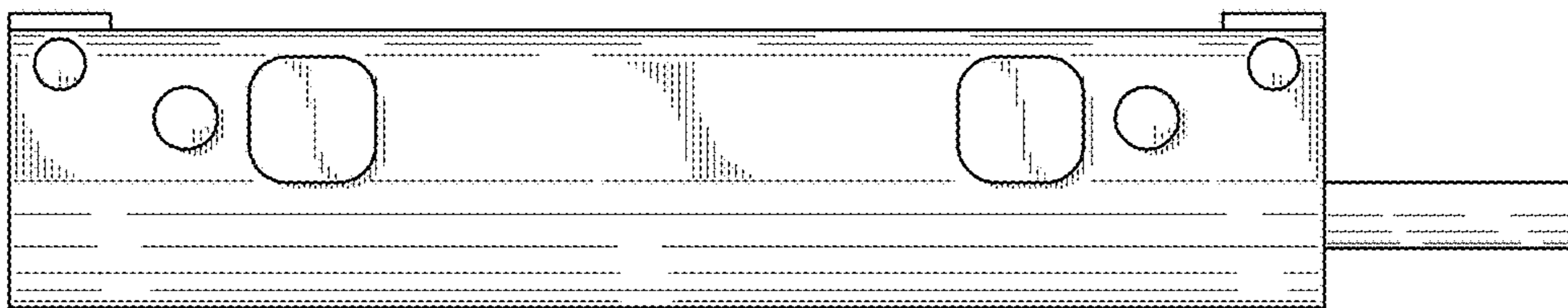

FIG. 14

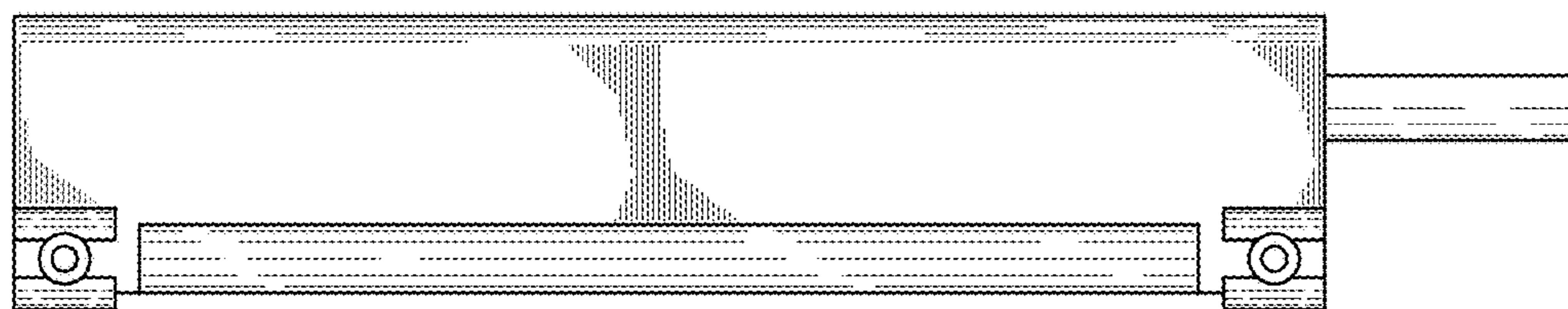



FIG. 15

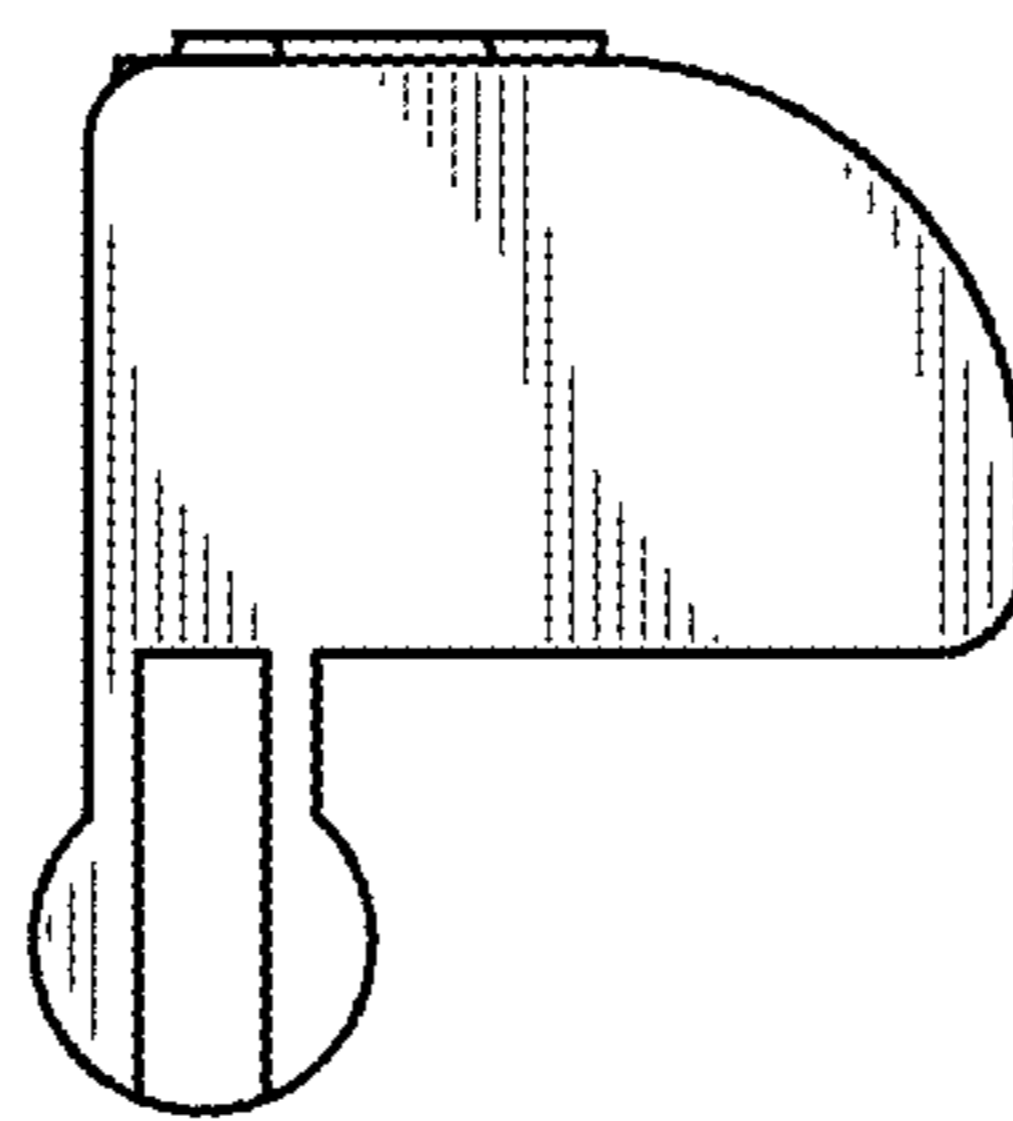

FIG. 16

