

US00D828612S

(12) **United States Design Patent** (10) **Patent No.:** **US D828,612 S**
Silver et al. (45) **Date of Patent:** **** Sep. 11, 2018**

(54) **LUMINAIRE**
(71) Applicant: **Beta-Calco Inc.**, Toronto (CA)
(72) Inventors: **Remy Silver**, Toronto (CA); **Patrick Stark**, Toronto (CA); **Andrei Dumitru**, Ajax (CA); **Wade Figueria**, Maple (CA)
(73) Assignee: **BETA-CALCO INC.**, Toronto (CA)

D683,066 S * 5/2013 Myung D26/120
D703,371 S * 4/2014 Yu D26/118
D716,486 S * 10/2014 Martin D26/141
D727,554 S * 4/2015 Clark D26/90
D735,928 S * 8/2015 Hawkins D26/120
D738,557 S * 9/2015 Colombo D26/85
2005/0183347 A1* 8/2005 Barry B27D 1/083
52/86
2013/0329424 A1* 12/2013 Clark F21S 2/005
362/235

(**) Term: **15 Years**

(21) Appl. No.: **29/567,693**

(22) Filed: **Jun. 10, 2016**

(30) **Foreign Application Priority Data**

May 6, 2016 (CA) 168370

(51) **LOC (11) Cl.** **26-03**

(52) **U.S. Cl.**
USPC **D26/91**; D26/90

(58) **Field of Classification Search**
USPC D26/72, 80, 81, 84, 85, 86, 88, 90, 91,
D26/118, 138, 142
CPC F21S 8/043; F21S 8/046; F21S 8/06; F21S
8/061; F21S 8/063; F21S 8/065; F21S
8/066; F21S 8/068; F21V 21/008; F21V
21/02; F21V 21/03; F21V 21/112; F21V
21/38

See application file for complete search history.

(56) **References Cited**

U.S. PATENT DOCUMENTS

D166,671 S * 5/1952 Jernigan D26/88
D313,669 S * 1/1991 Sonneman D26/85
D386,801 S * 11/1997 Orgovan D26/72
D487,528 S * 3/2004 Christensen D26/85
D565,786 S * 4/2008 Willmorth D26/138
D591,443 S * 4/2009 Beno D26/76
D591,444 S * 4/2009 Beno D26/76
D605,336 S * 12/2009 Miranda D26/90
D606,923 S * 12/2009 Young D12/345
D633,646 S * 3/2011 Marcaccio D26/118

OTHER PUBLICATIONS

Optelma Architechtural Lighting "QUAD" Curved linear lighting system. Product Description Sheet dated Aug. 2016.*
Sattler—Anello, <https://web.archive.org/web/20151117014745/http://www.sattler-lighting.com/en/portfolio/anello/>, Nov. 17, 2015.
Sattler—Circolo, <https://web.archive.org/web/20150417071940/http://www.sattler-lighting.com/en/portfolio/circolo-2/>, Apr. 17, 2015.
Sattler—Circolo Mini, <https://web.archive.org/web/20150914043313/http://www.sattler-lighting.com/en/portfolio/circolo-mini/>, Sep. 14, 2015.
Sattler—Ellipse, <https://web.archive.org/web/20150202034107/http://www.sattler-lighting.com/en/portfolio/ellipse-2/>, Feb. 2, 2015.
Sattler—Girata Horizontal, <https://web.archive.org/web/20150411064205/http://www.sattler-lighting.com/en/portfolio/girata-horizontal-2/>, Apr. 11, 2015.
Sattler—Inizio, <https://web.archive.org/web/20150912215119/http://www.sattler-lighting.com/en/portfolio/inizio/>, Sep. 12, 2015.
Sattler—Insieme, <https://web.archive.org/web/20150913045059/http://www.sattler-lighting.com/en/portfolio/insieme-2/>, Sep. 13, 2015.
Sattler—Insospeso Pendant, <https://web.archive.org/web/20141104084223/http://www.sattler-lighting.com/en/portfolio/insospeso-pendant/>, Nov. 4, 2014.
Sattler—Luce Verde Anello, <https://web.archive.org/web/20151031175922/http://www.sattler-lighting.com/en/portfolio/luce-verde-anello-2/>, Oct. 31, 2015.
Sattler—Luce Verde Slim, <https://web.archive.org/web/20151031150233/http://www.sattler-lighting.com/en/portfolio/luce-verde-slim-2/>, Oct. 31, 2015.
Sattler—Anello, North American Version, Specification Sheet (Jan. 11, 2016), p. 25 and 26.
Sattler—Slim Direct, North-American Version, Specification Sheet (Jan. 11, 2016), p. 52 and 53.
Sattler—Slim Indirect, North American Version, Specification Sheet (Jan. 11, 2016), p. 50 and 51.

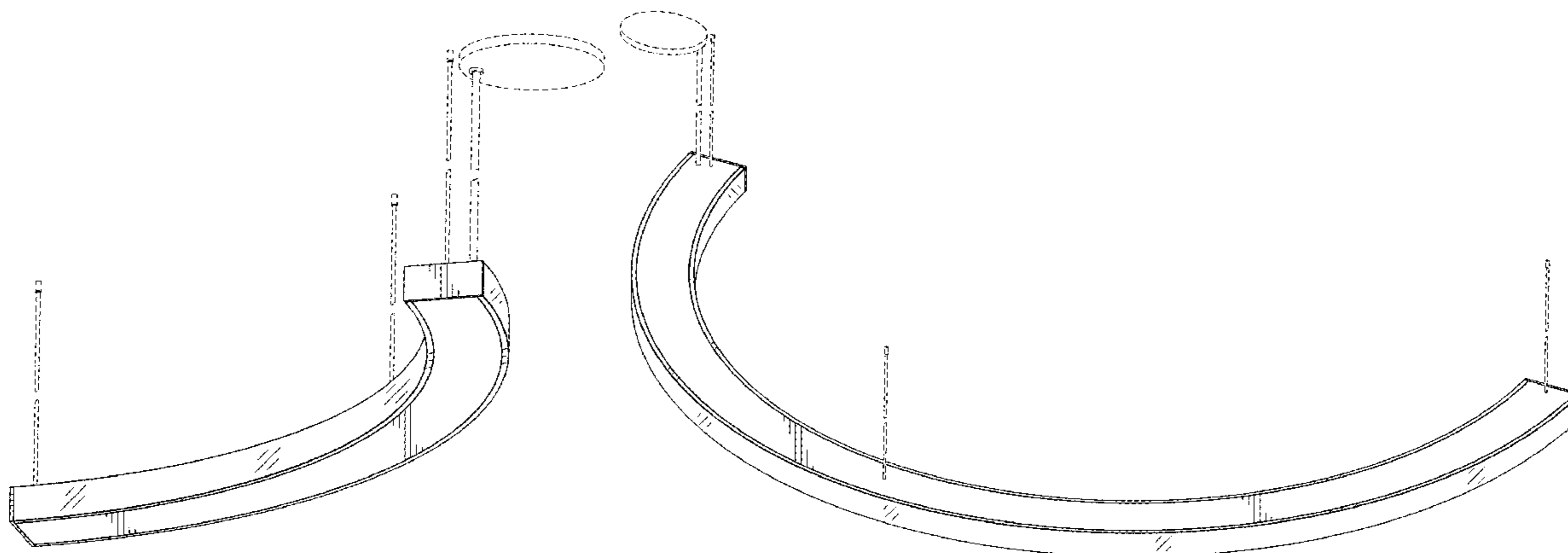

Sattler Products, <https://web.archive.org/web/20160101170826/http://www.sattler-lighting.com/en/products/>, Jan. 1, 2016.

Sattler—Slim, <https://web.archive.org/web/20160127025133/http://www.sattler-lighting.com/en/portfolio/slim/>, Jan. 27, 2016.

Sattler—Toccatà, <https://web.archive.org/web/20151008144855/http://www.sattler-lighting.com/en/portfolio/toccatà-2/>, Oct. 3, 2015.

Sattler—Unione, <https://www.sattler-lighting.com/en/portfolio/unione/>, Sep. 11, 2015.

Lightnet—Ringo Star, <https://web.archive.org/web/20160118012808/http://lightnet.us/ringo-star-pigl-led-5.phtml>, Jan. 18, 2016.

Lightnet—Ringo Star 6, <http://www.lightnet.us/ringo-star-6.phtml>, Jan. 9, 2016.

Birchwood Lighting—Charlotte, <https://web.archive.org/web/20160407203212/http://birchwoodlighting.com/products/charlotte.html>, Apr. 7, 2016.

Birchwood Lighting—Charlotte, 3.25" Direct Distribution, Fixture Specification Sheet, https://web.archive.org/web/20151223113223/http://www.birchwoodlighting.com/products/pdfs/charlotte_dr.pdf, Dec. 23, 2015.

Birchwood Lighting—Charlotte, 3.25" Direct/Indirect Distribution, Fixture Specification Sheet, https://web.archive.org/web/20151123042829/http://www.birchwoodlighting.com/products/pdfs/charlotte_drin.pdf, Nov. 23, 2015.

Birchwood Lighting—Katrina, <https://web.archive.org/web/20160409083119/http://birchwoodlighting.com/products/katrina.html>, Apr. 9, 2016.

Birchwood Lighting—Katrina, Fixture Specification, <https://web.archive.org/web/20151223115316/http://www.birchwoodlighting.com/products/pdfs/katrina.pdf>, Dec. 23, 2015.

Castaldi Lighting—Norlight Bubble; <https://web.archive.org/web/20150614045241/http://www.castaldilighting.me.uk/products/bubble>, Jun. 14, 2015.

Castaldi Lighting—Norlight Bubble Up; https://web.archive.org/web/20150617050535/http://www.castaldilighting.me.uk/products/bubble_up, Jun. 17, 2015.

Castaldi Lighting—Norlight Half; <https://web.archive.org/web/20150617050802/http://www.castaldilighting.me.uk/products/half>, Jun. 17, 2004.

Eureka Lighting—Cycle 3800-24, -36, 54, -72 Specification, 2014.

Eureka Lighting—Cycle 3800-24, -36, -54, -72 Specification (2), 2014.

Eureka Lighting—Cycle 4800-54-WH; <https://web.archive.org/web/20160402100726/http://www.eurekalighting.com/productDetails.aspx?productId=4800-54&Cat=E4B>, Apr. 2, 2016.

Eureka Lighting—Cycle 4800-72-WH; <https://web.archive.org/web/20150214032441/http://www.eurekalighting.com/productDetails.aspx?productId=4800-72&Cat=E4B>, Feb. 14, 2015.

Eureka Lighting—Cycle 4800-24/36 Product Sheet, printed prior to Apr. 22, 2016.

Eureka Lighting—Cycle 4800-54/72 Product Sheet, 2015.

Eureka Lighting—Cycle 4800-115/152 Product Sheet, 2015.

Eureka Lighting—Cycle Layers 4844-2 Specification, 2015.

Eureka Lighting—Cycle Layers 4844-3 Specification, 2015.

Eureka Lighting Product Page Snapshot of 3800 Cycle Series; <https://web.archive.org/web/20150426170634/http://www.eurekalighting.com/productscategory.aspx?page=1&cat=ALL>, Apr. 26, 2015.

Eureka Lighting Product Page Snapshot of 4800 Cycle Series and Odeon; <https://web.archive.org/web/20150426170634/http://www.eurekalighting.com/productscategory.aspx?page=1&cat=ALL>, Apr. 26, 2015.

Eureka Lighting—Odeon 4805-80/118 Specification; 2014-2015.

Beta-Calco—Bubble, Web Pin 298, General Specification, Jul. 21, 2014.

Beta Calco—Bubble 3D, Web Pin 117, General Specification, Mar. 31, 2014.

Beta Calco—Bubble 3D RGB, Web Pin 259, General Specification, Jul. 21, 2014.

Beta Calco—Bubble RGB; Web Pin 260, General Specification; Jul. 21, 2014.

Beta Calco—Bubble Up, Web Pin 433, General Specification, Jul. 21, 2014.

Beta Calco—United Utilities, Q-06825 Quarter Ring 2, General Specification, Mar. 2015.

Beta Calco—Ring, White LED Direct Illumination, Web Pin 100, General Specification, Apr. 1, 2015.

Beta Calco—Ring, White LED Direct & Indirect Illumination, Web Pin 100, General Specification, Mar. 31, 2015.

Beta Calco—Ring, Static Color LED Direct Illumination, Web Pin 100, General Specification, May 5, 2015.

* cited by examiner

Primary Examiner — Clare E Heflin

(74) *Attorney, Agent, or Firm* — Renner, Otto, Boisselle & Sklar, LLP

(57) **CLAIM**

The ornamental design for a luminaire, as shown and described.

DESCRIPTION

FIG. 1 is a perspective view of a luminaire showing a first variant of the design;

FIG. 2 is a top view of the luminaire of FIG. 1;

FIG. 3 is a bottom view of the luminaire of FIG. 1;

FIG. 4 is a front view of the luminaire of FIG. 1;

FIG. 5 is a rear view of the luminaire of FIG. 1;

FIG. 6 is a right side view of the luminaire of FIG. 1;

FIG. 7 is a left side view of the luminaire of FIG. 1;

FIG. 8 is a perspective view of a luminaire showing a second variant of the design;

FIG. 9 is a top view of the luminaire of FIG. 8;

FIG. 10 is a bottom view of the luminaire of FIG. 8;

FIG. 11 is a front view of the luminaire of FIG. 8;

FIG. 12 is a rear view of the luminaire of FIG. 8;

FIG. 13 is a right side view of the luminaire of FIG. 8;

FIG. 14 is a left side view of the luminaire of FIG. 8;

FIG. 15 is a perspective view of a luminaire showing a third variant of the design;

FIG. 16 is a top view of the luminaire of FIG. 15;

FIG. 17 is a bottom view of the luminaire of FIG. 15;

FIG. 18 is a front view of the luminaire of FIG. 15;

FIG. 19 is a rear view of the luminaire of FIG. 15;

FIG. 20 is a right side view of the luminaire of FIG. 15;

FIG. 21 is a left side view of the luminaire of FIG. 15;

FIG. 22 is a perspective view of a luminaire showing a fourth variant of the design;

FIG. 23 is a top view of the luminaire of FIG. 22;

FIG. 24 is a bottom view of the luminaire of FIG. 22;

FIG. 25 is a front view of the luminaire of FIG. 22;

FIG. 26 is a rear view of the luminaire of FIG. 22;

FIG. 27 is a right side view of the luminaire of FIG. 22;

FIG. 28 is a left side view of the luminaire of FIG. 22;

FIG. 29 is a perspective view of a luminaire showing a fifth variant of the design;

FIG. 30 is a top view of the luminaire of FIG. 29;

FIG. 31 is a bottom view of the luminaire of FIG. 29;

FIG. 32 is a front view of the luminaire of FIG. 29;

FIG. 33 is a rear view of the luminaire of FIG. 29;

FIG. 34 is a right side view of the luminaire of FIG. 29;

FIG. 35 is a left side view of the luminaire of FIG. 29;

FIG. 36 is a perspective view of a luminaire showing a sixth variant of the design;

FIG. 37 is a top view of the luminaire of FIG. 36;

FIG. 38 is a bottom view of the luminaire of FIG. 36;
FIG. 39 is a front view of the luminaire of FIG. 36;
FIG. 40 is a rear view of the luminaire of FIG. 36;
FIG. 41 is a right side view of the luminaire of FIG. 36;
FIG. 42 is a left side view of the luminaire of FIG. 36;
FIG. 43 is a perspective view of a luminaire showing a seventh variant of the design;
FIG. 44 is a top view of the luminaire of FIG. 43;
FIG. 45 is a bottom view of the luminaire of FIG. 43;
FIG. 46 is a front view of the luminaire of FIG. 43;
FIG. 47 is a rear view of the luminaire of FIG. 43;
FIG. 48 is a right side view of the luminaire of FIG. 43;
FIG. 49 is a left side view of the luminaire of FIG. 43;
FIG. 50 is a perspective view of a luminaire showing an eighth variant of the design;
FIG. 51 is a top view of the luminaire of FIG. 50;
FIG. 52 is a bottom view of the luminaire of FIG. 50;
FIG. 53 is a front view of the luminaire of FIG. 50;
FIG. 54 is a rear view of the luminaire of FIG. 50;
FIG. 55 is a right side view of the luminaire of FIG. 50; and,
FIG. 56 is a left side view of the luminaire of FIG. 50.
The portions of the luminaire shown in broken lines form no part of the design. The thin diagonal lines on the inner and outer side walls of the luminaire represent translucency.

1 Claim, 35 Drawing Sheets

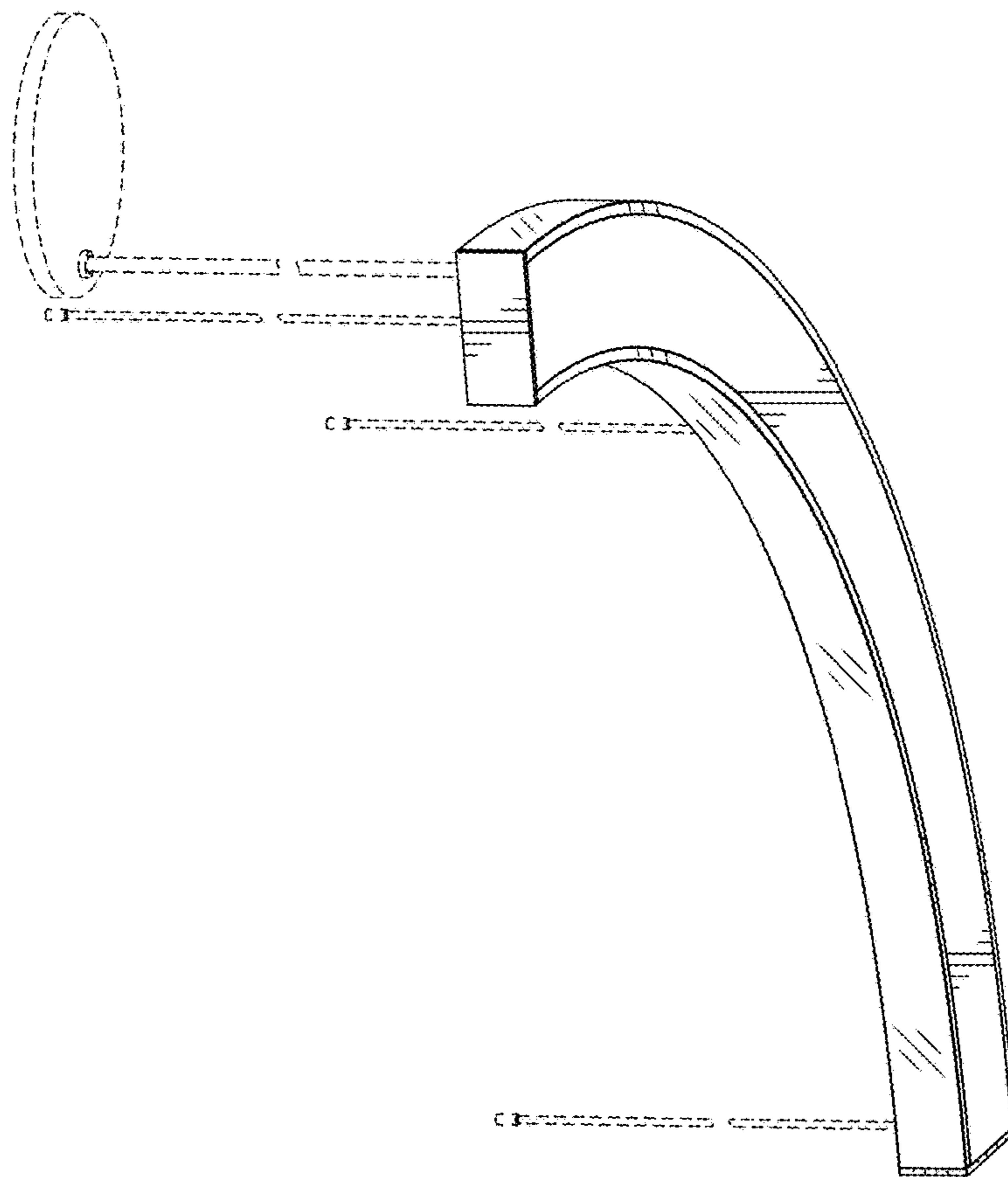

FIG. 1

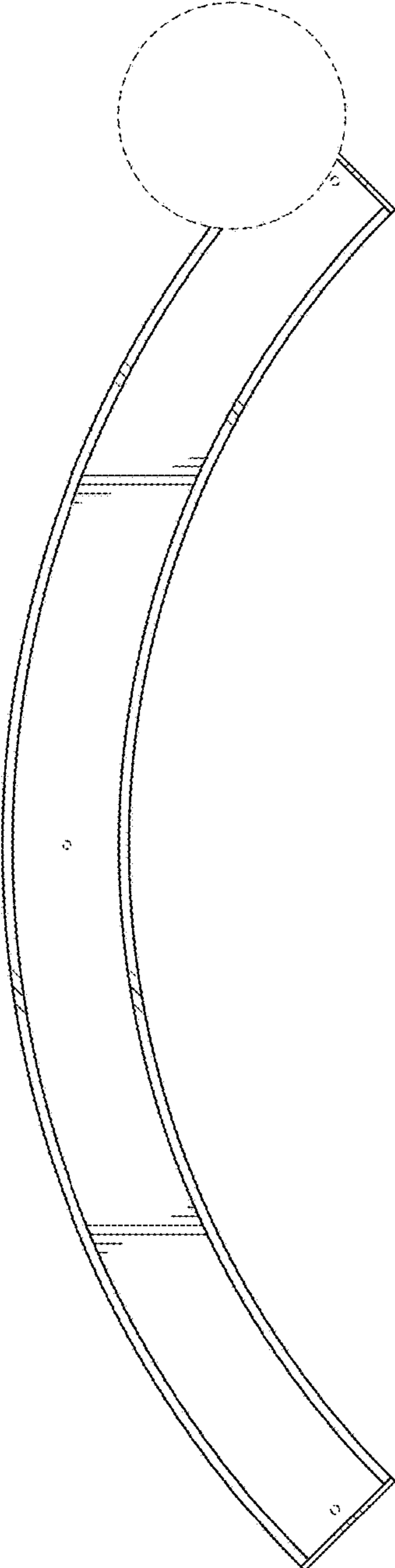

FIG. 2

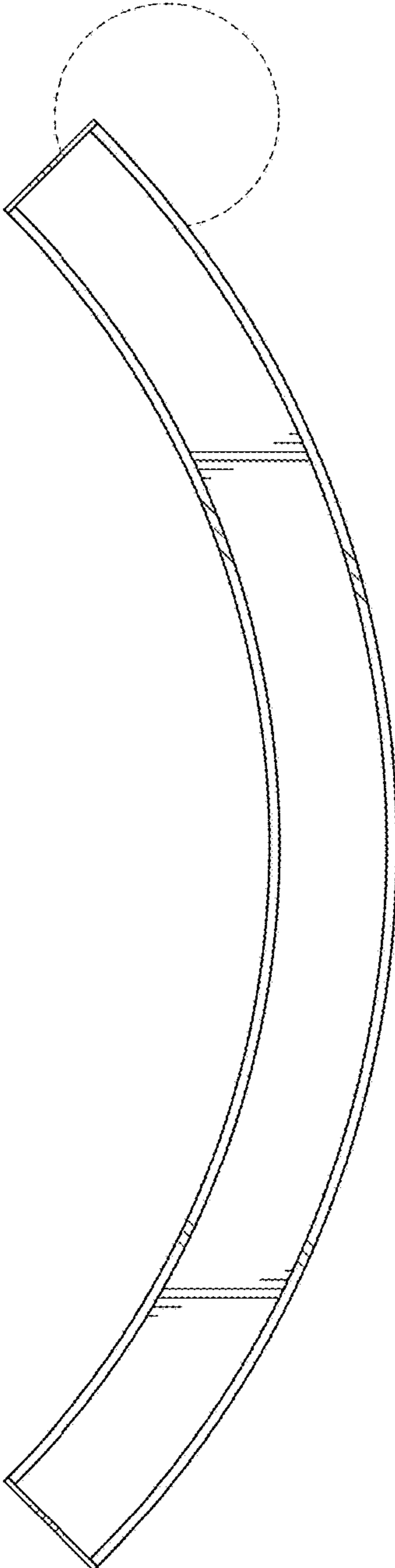

FIG. 3

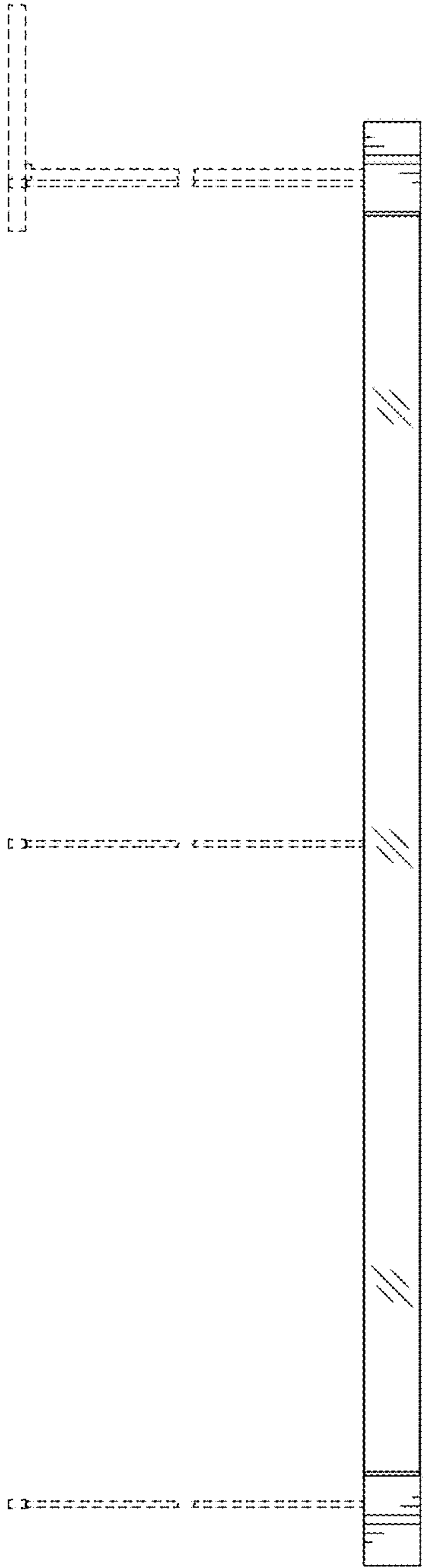

FIG. 4

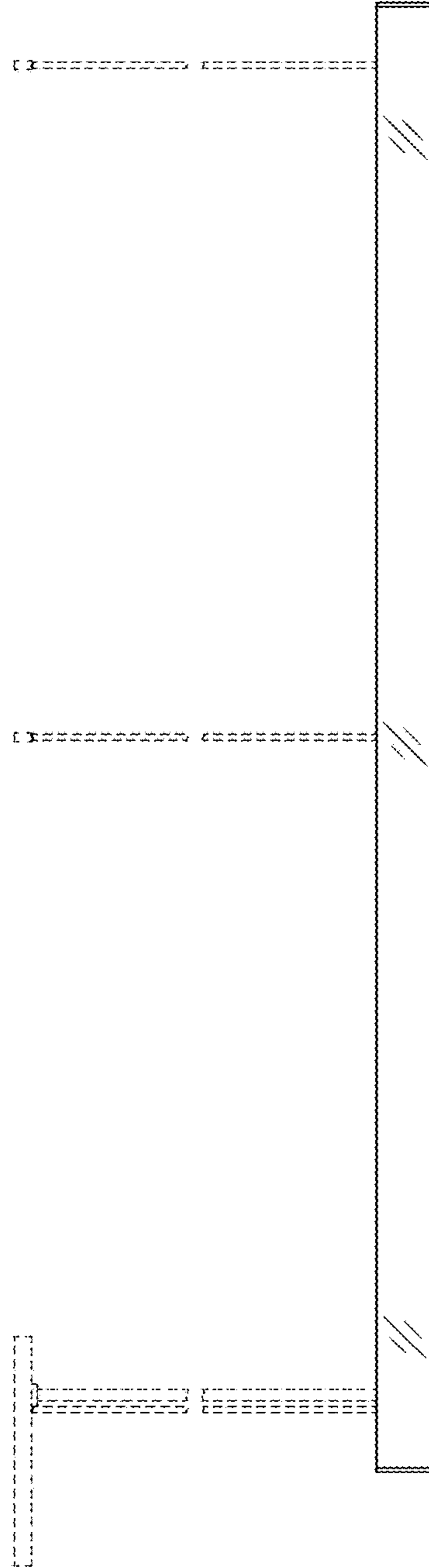

FIG. 5

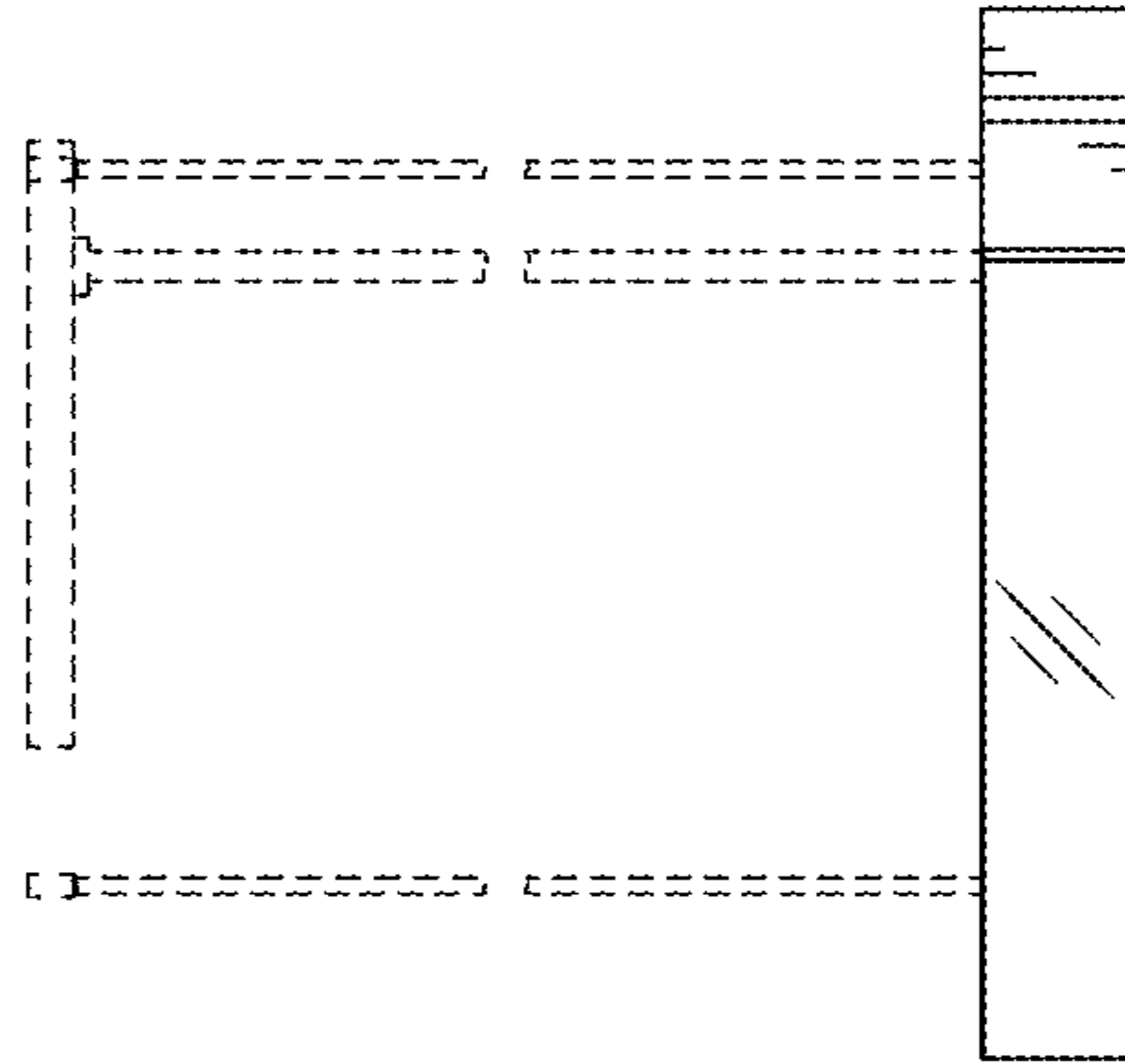

FIG. 6

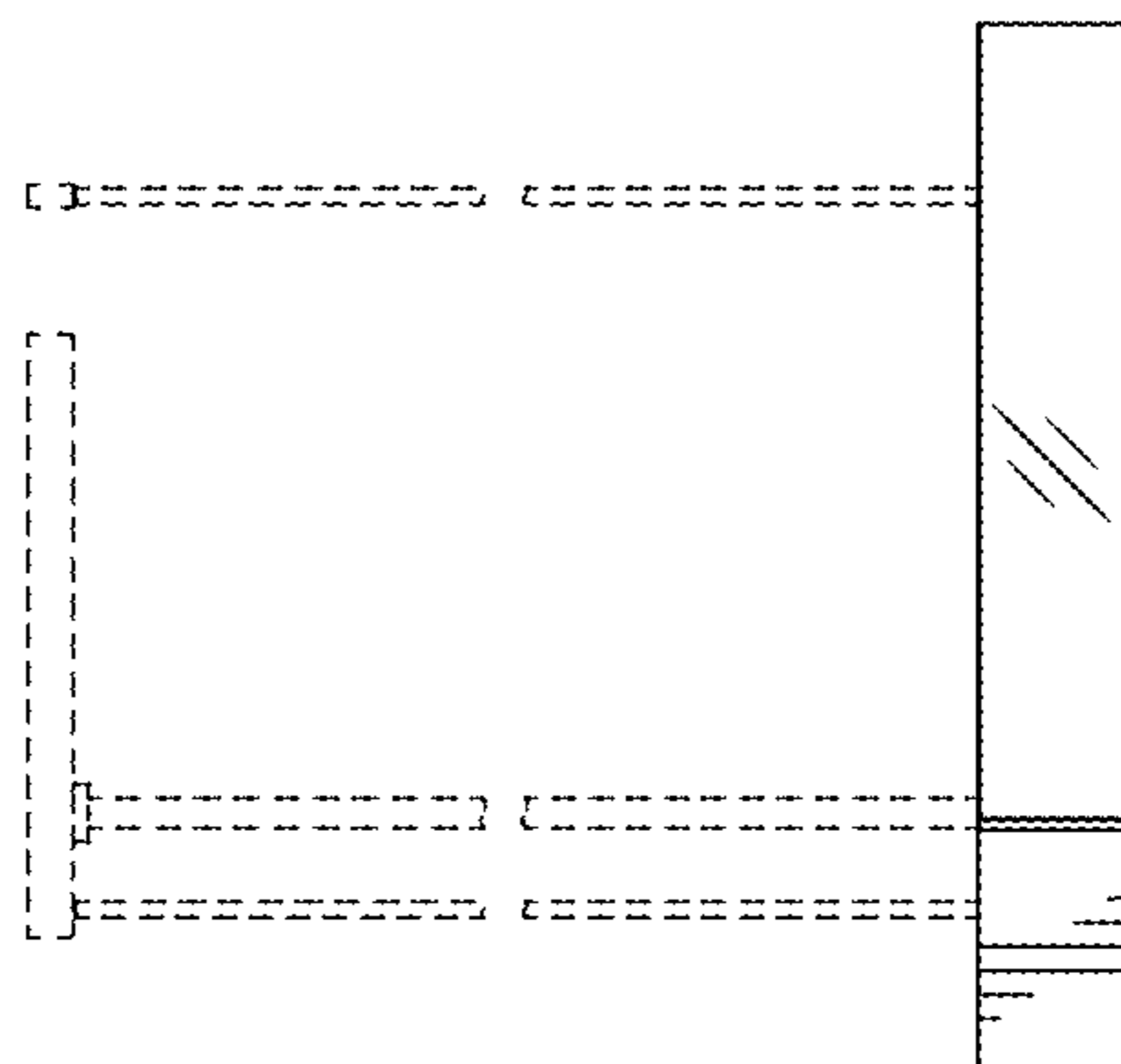

FIG. 7

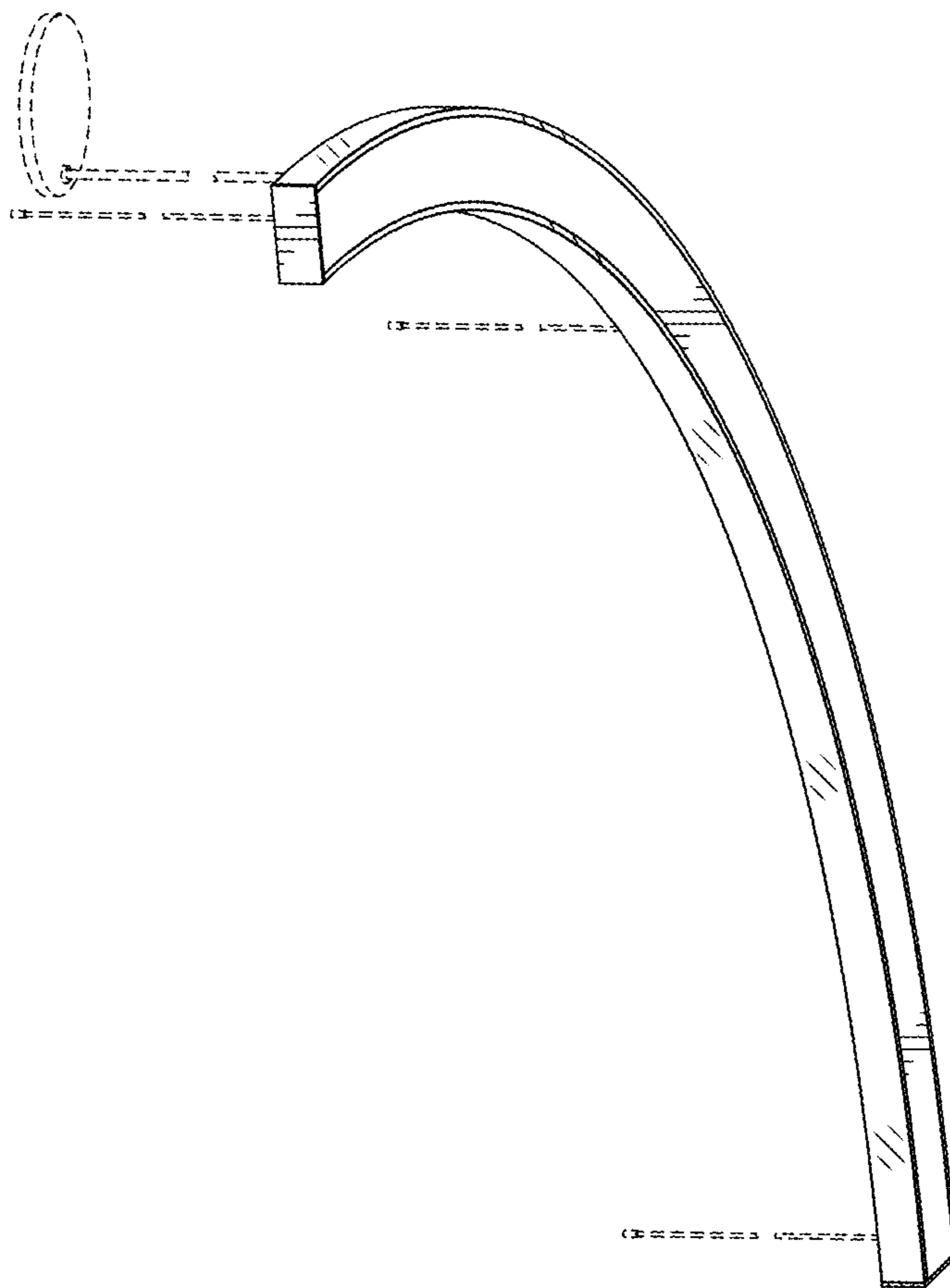

FIG. 8

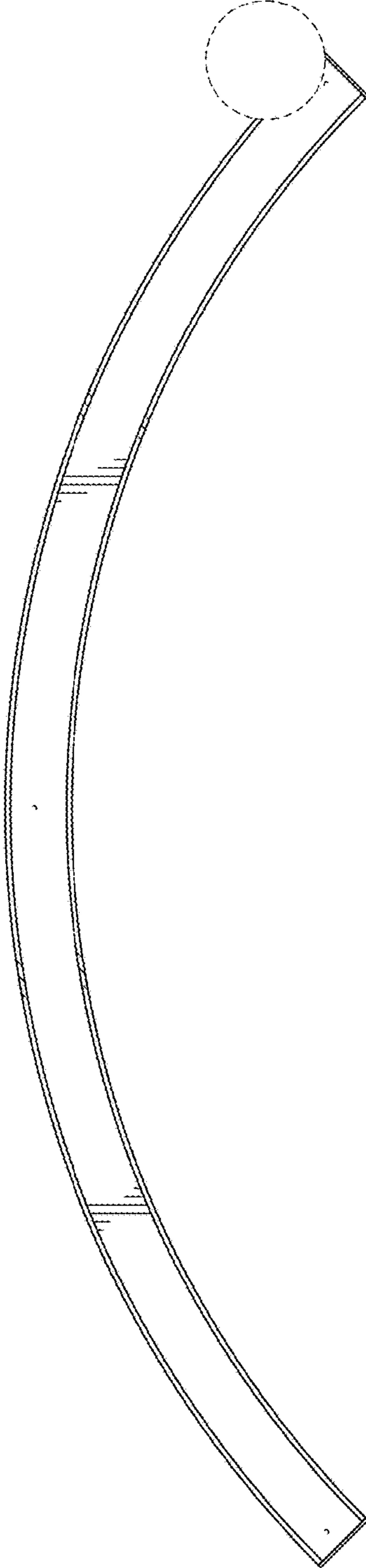

FIG. 9

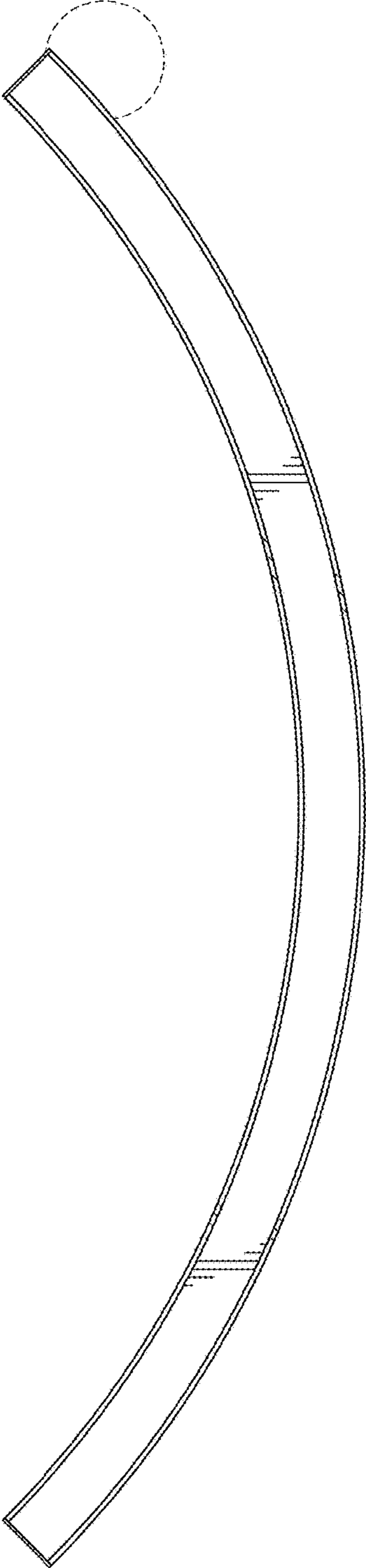

FIG. 10

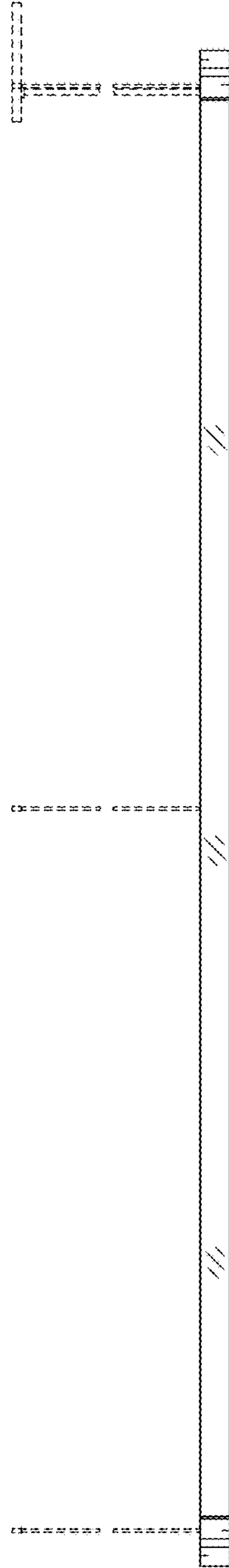

FIG. 11

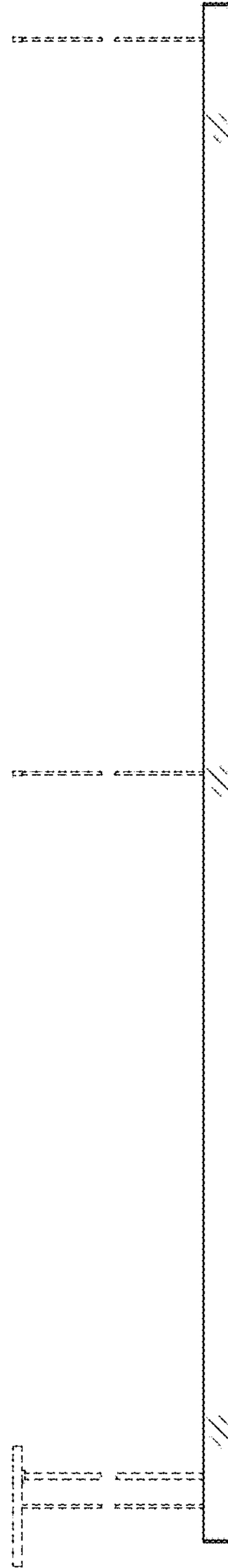

FIG. 12

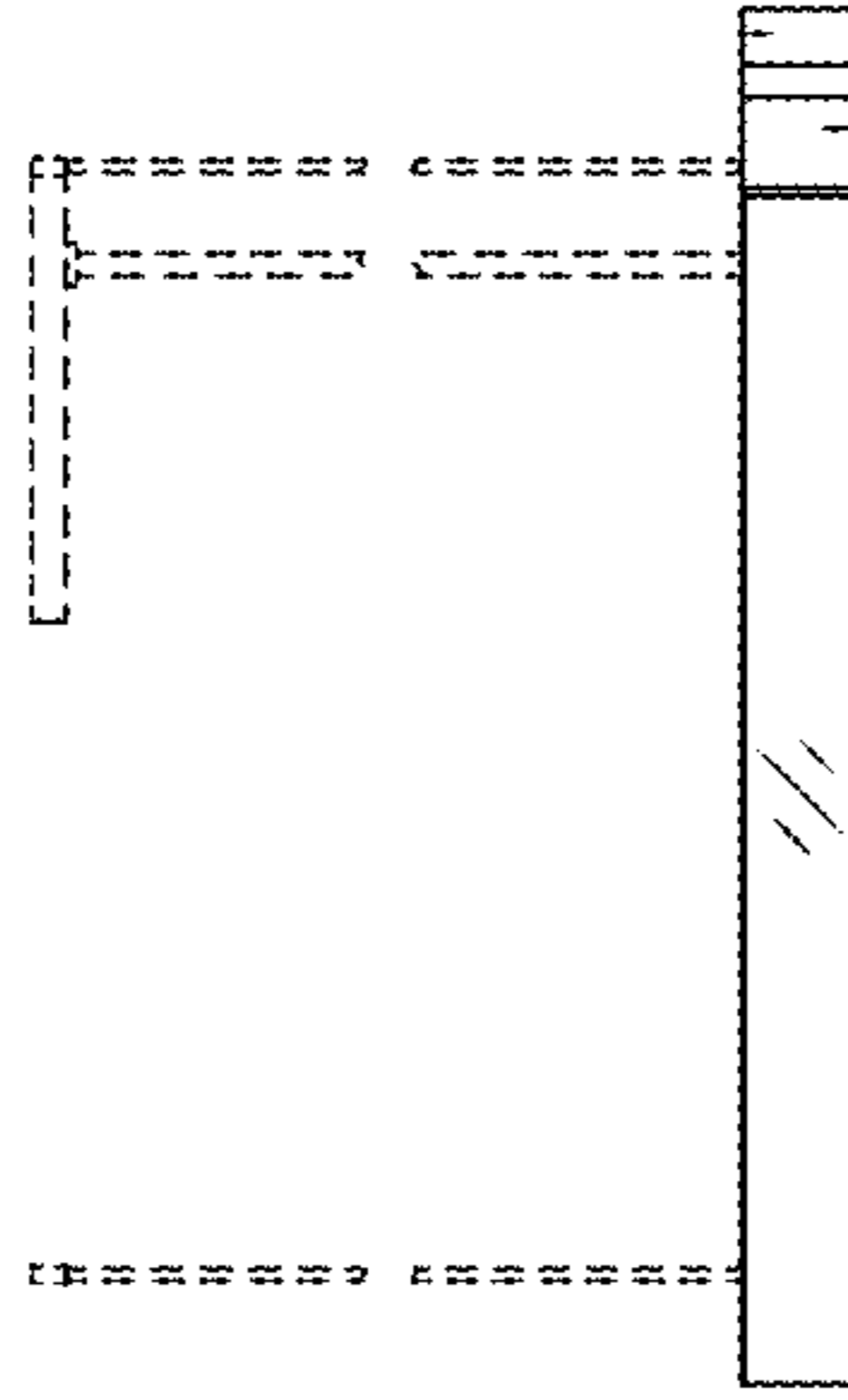

FIG. 13

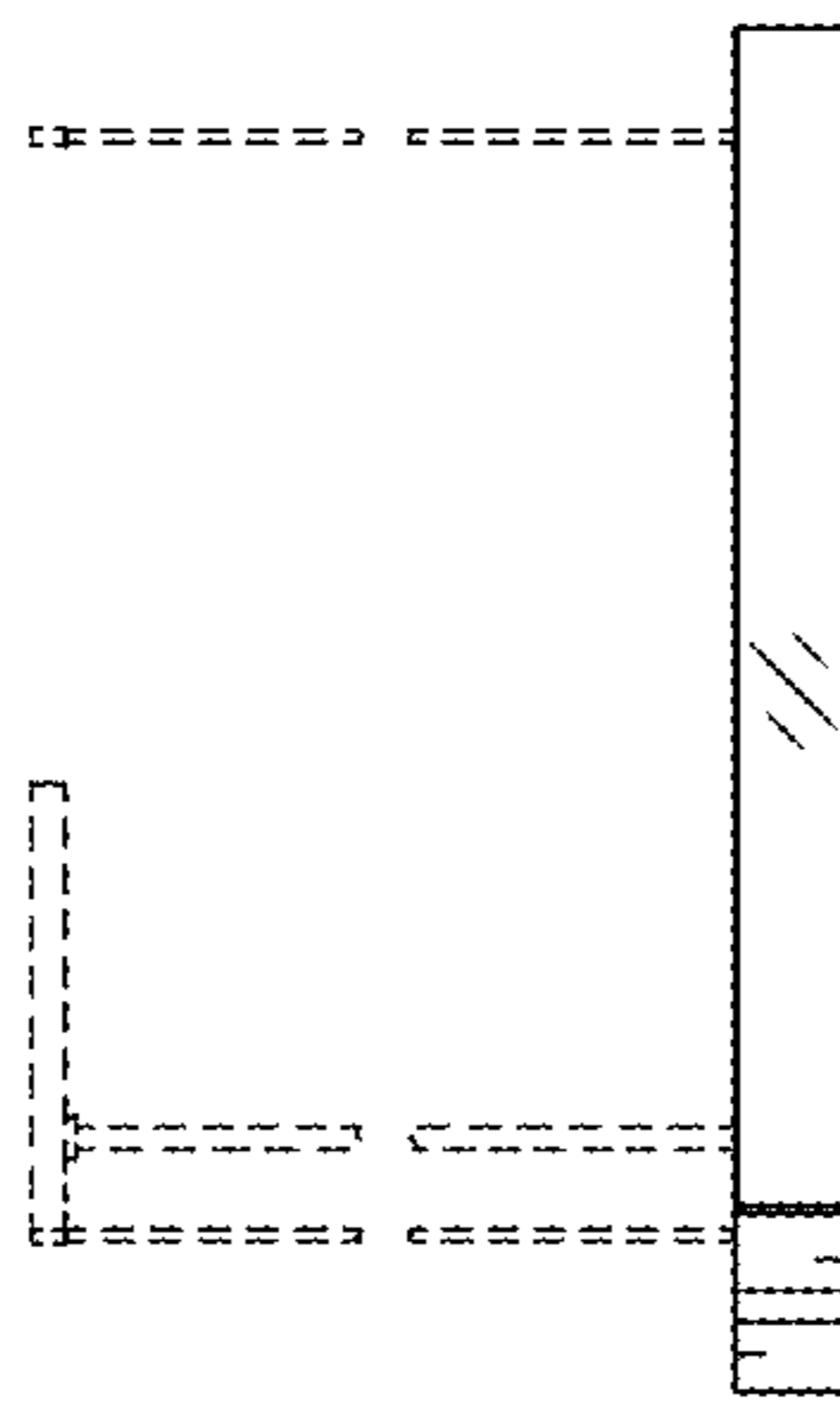

FIG. 14

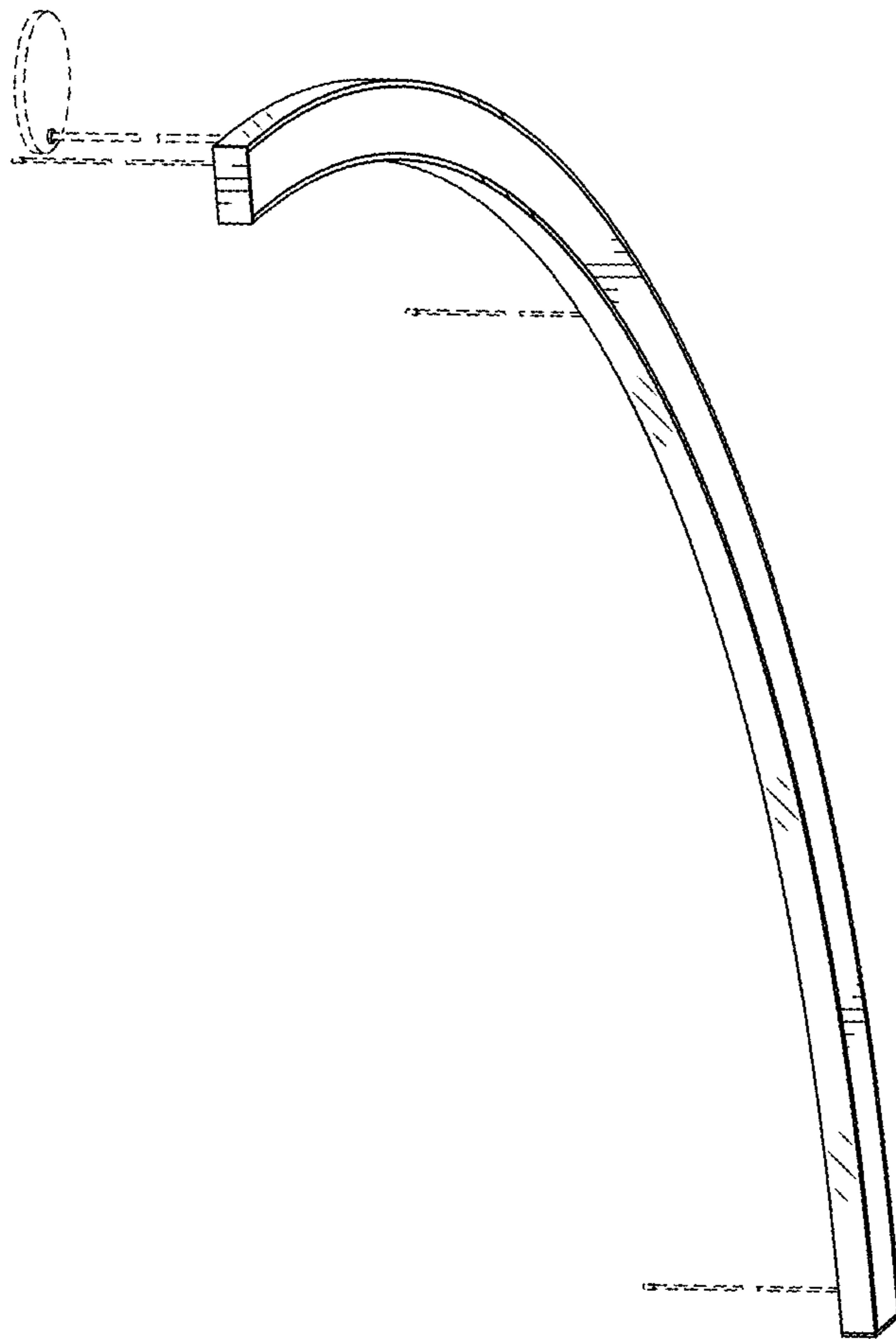

FIG. 15

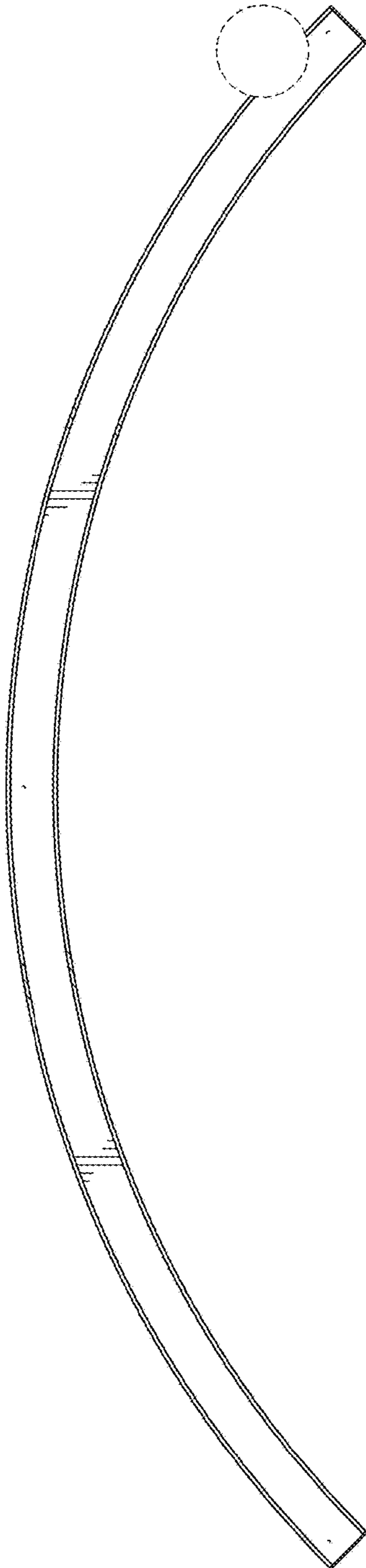

FIG. 16

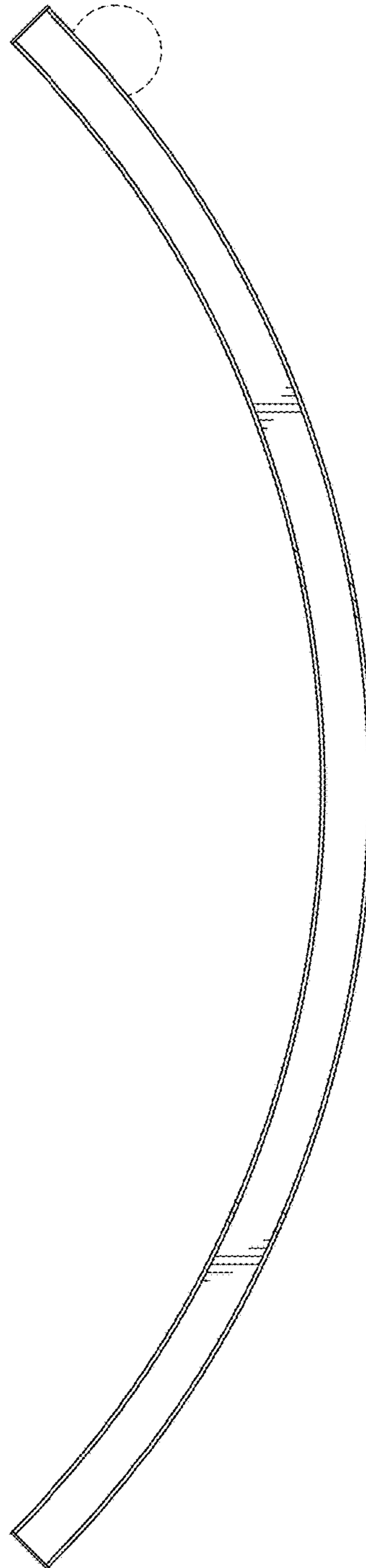

FIG. 17

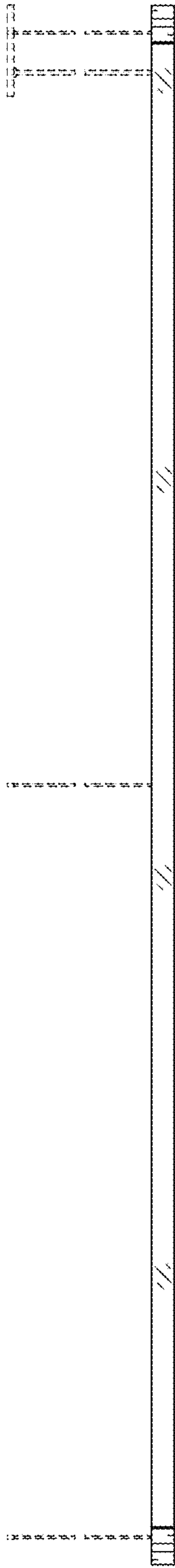

FIG. 18

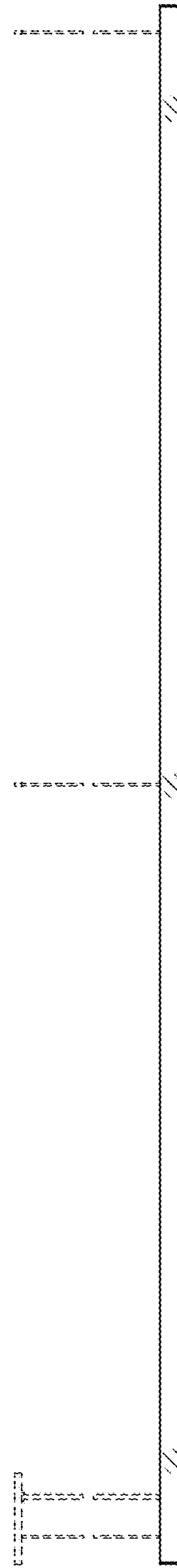

FIG. 19

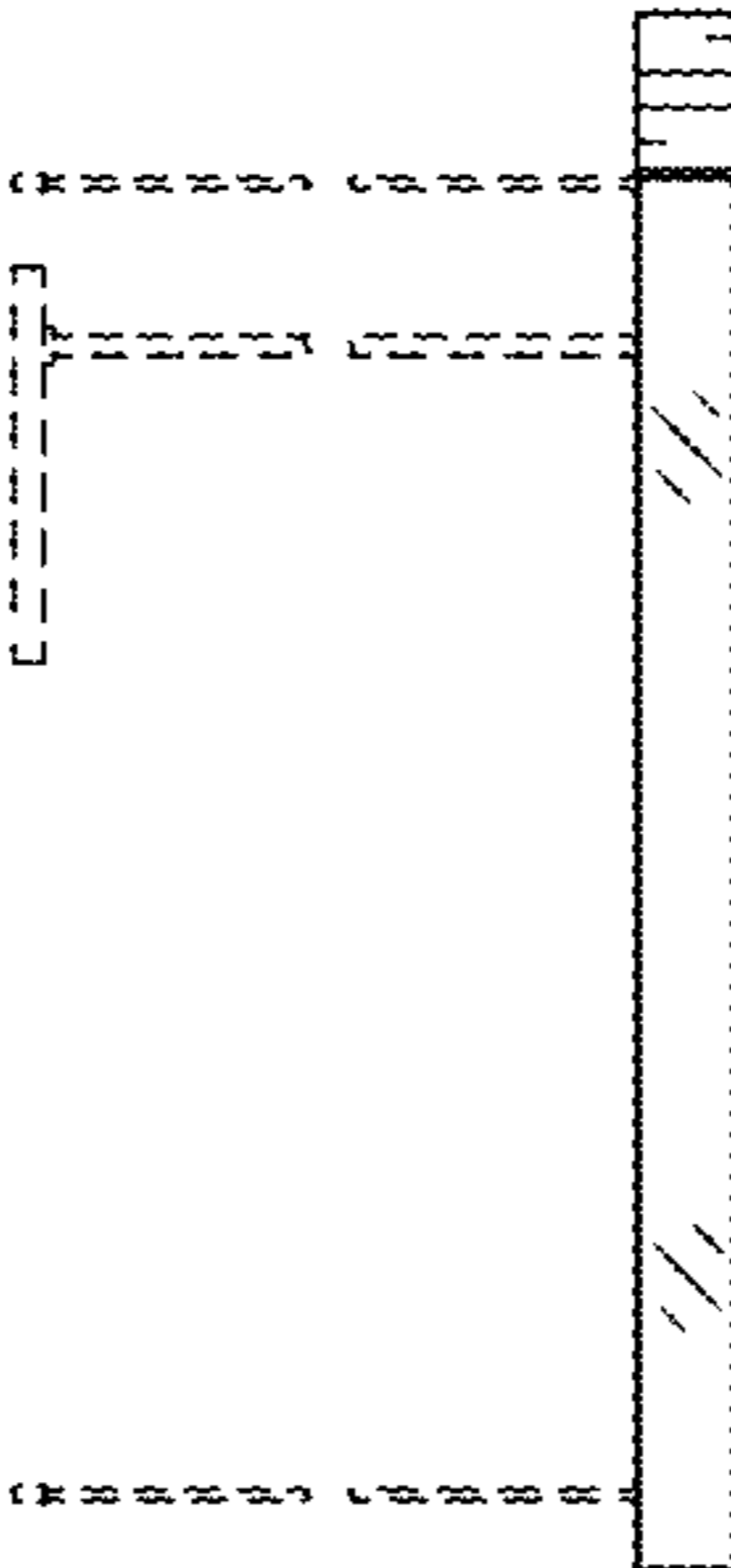

FIG. 20



FIG. 21

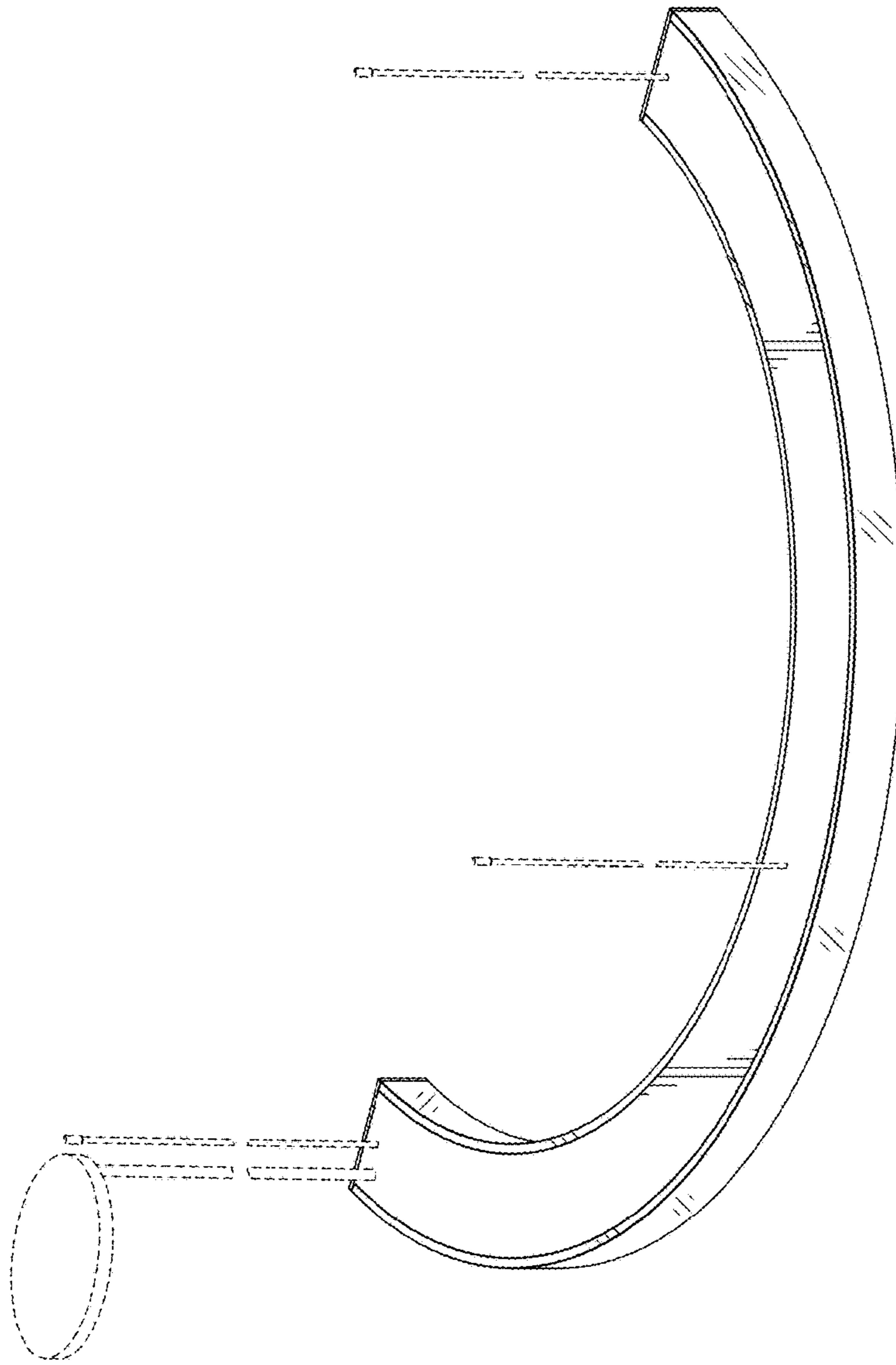

FIG. 22

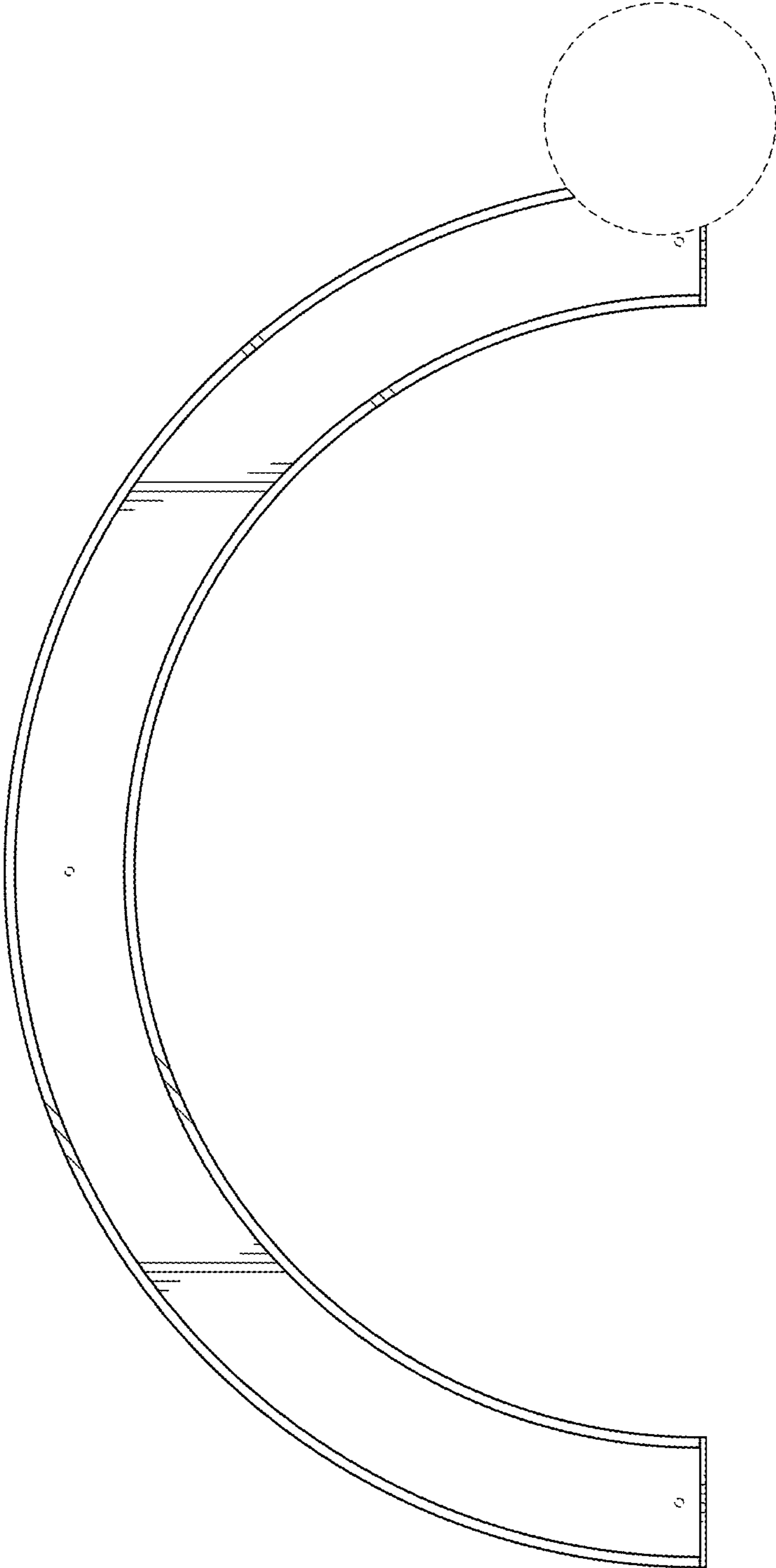

FIG. 23

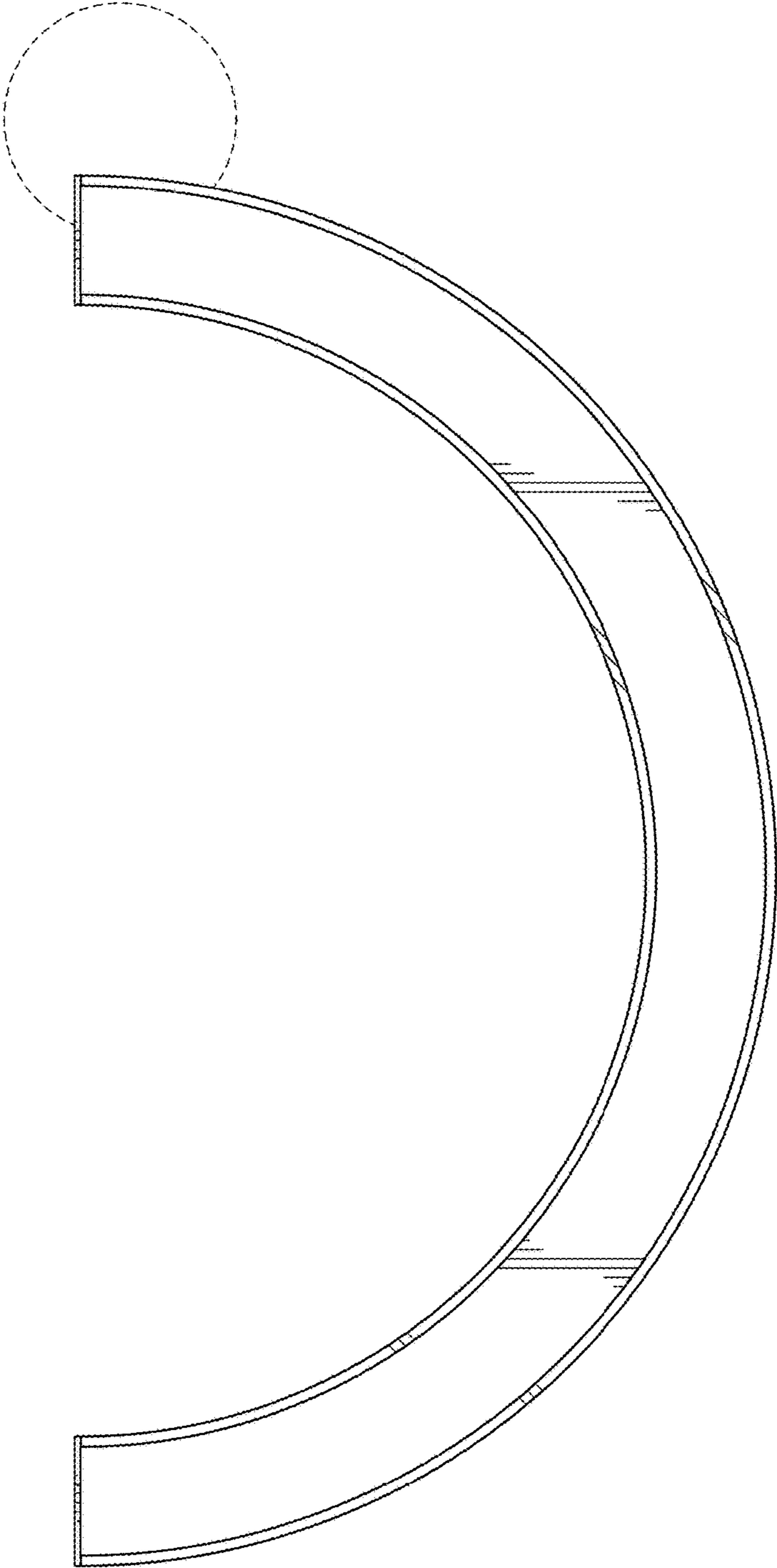

FIG. 24

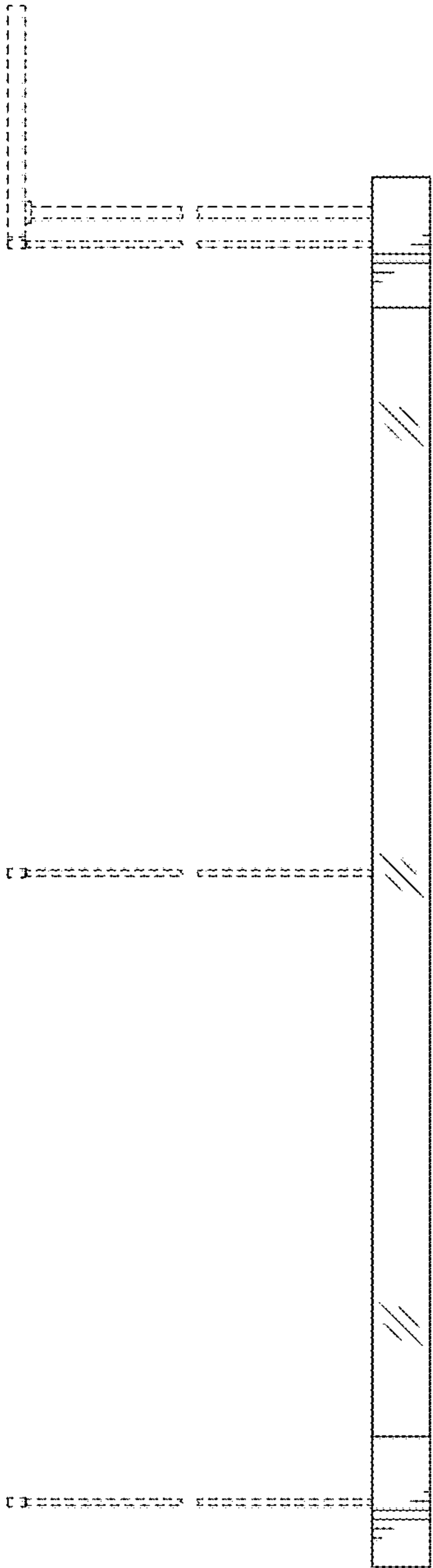

FIG. 25

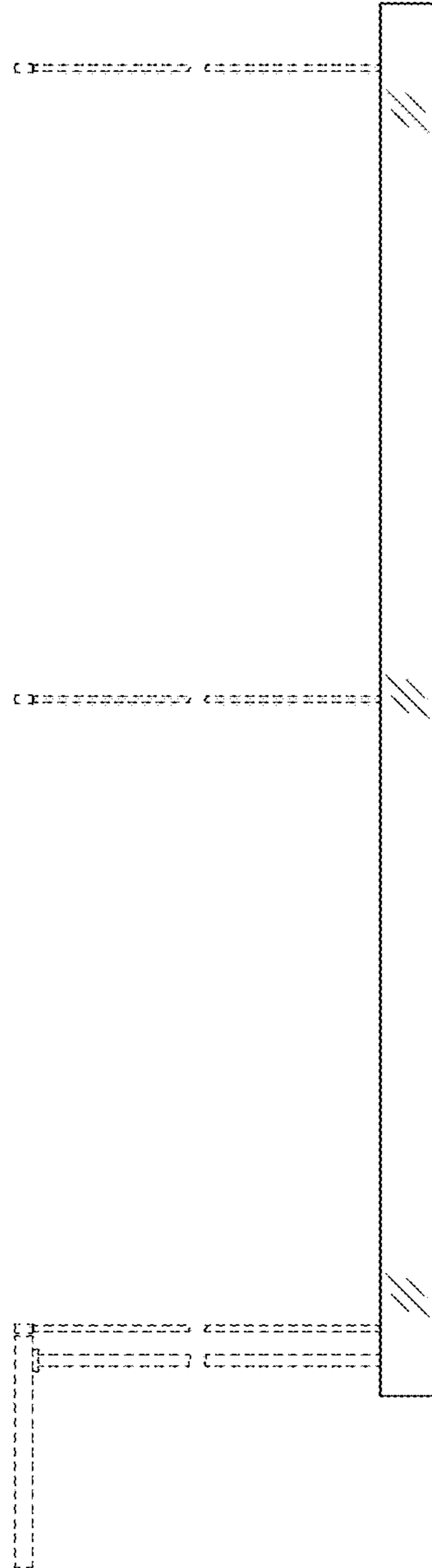

FIG. 26

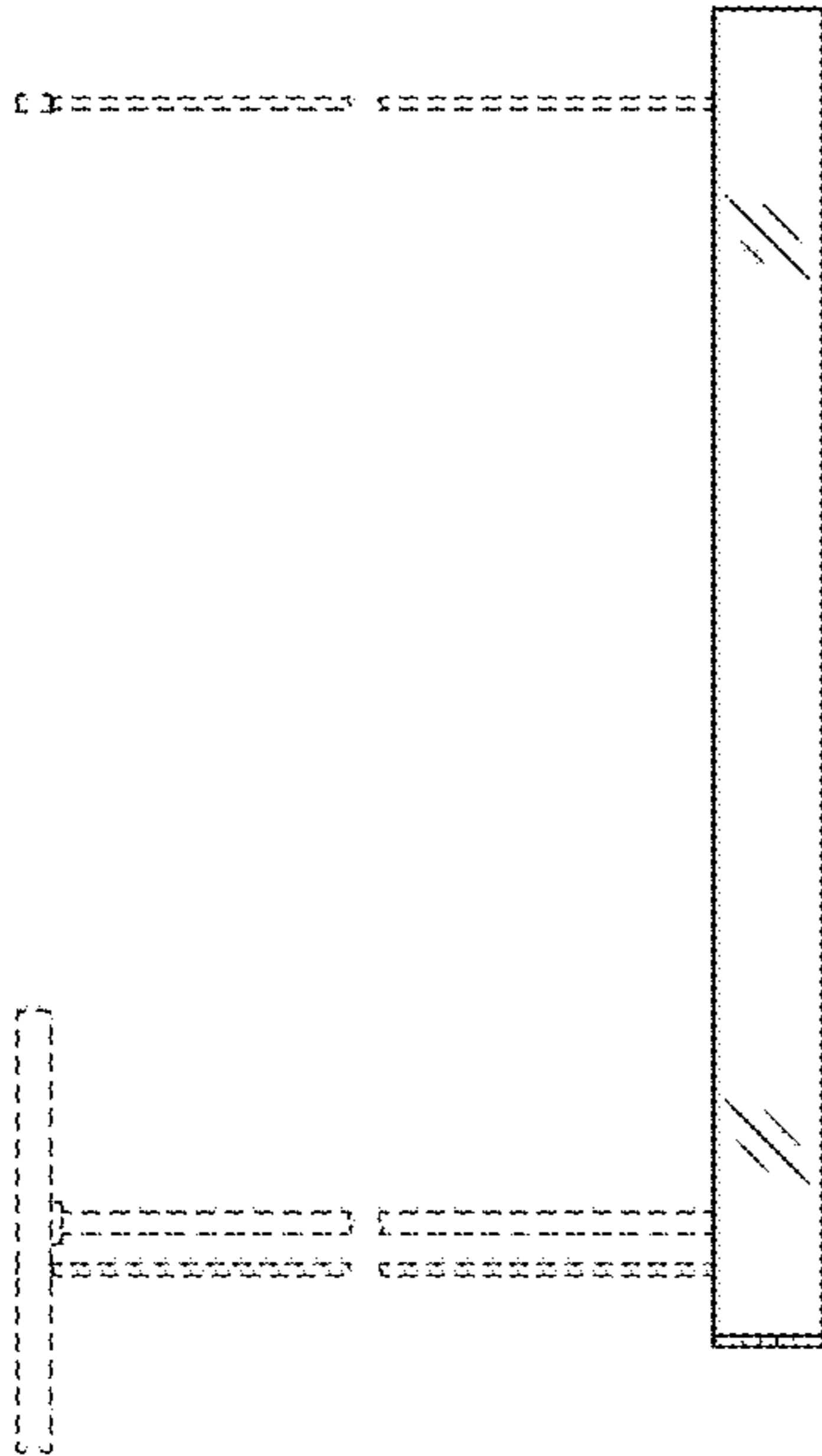

FIG. 27

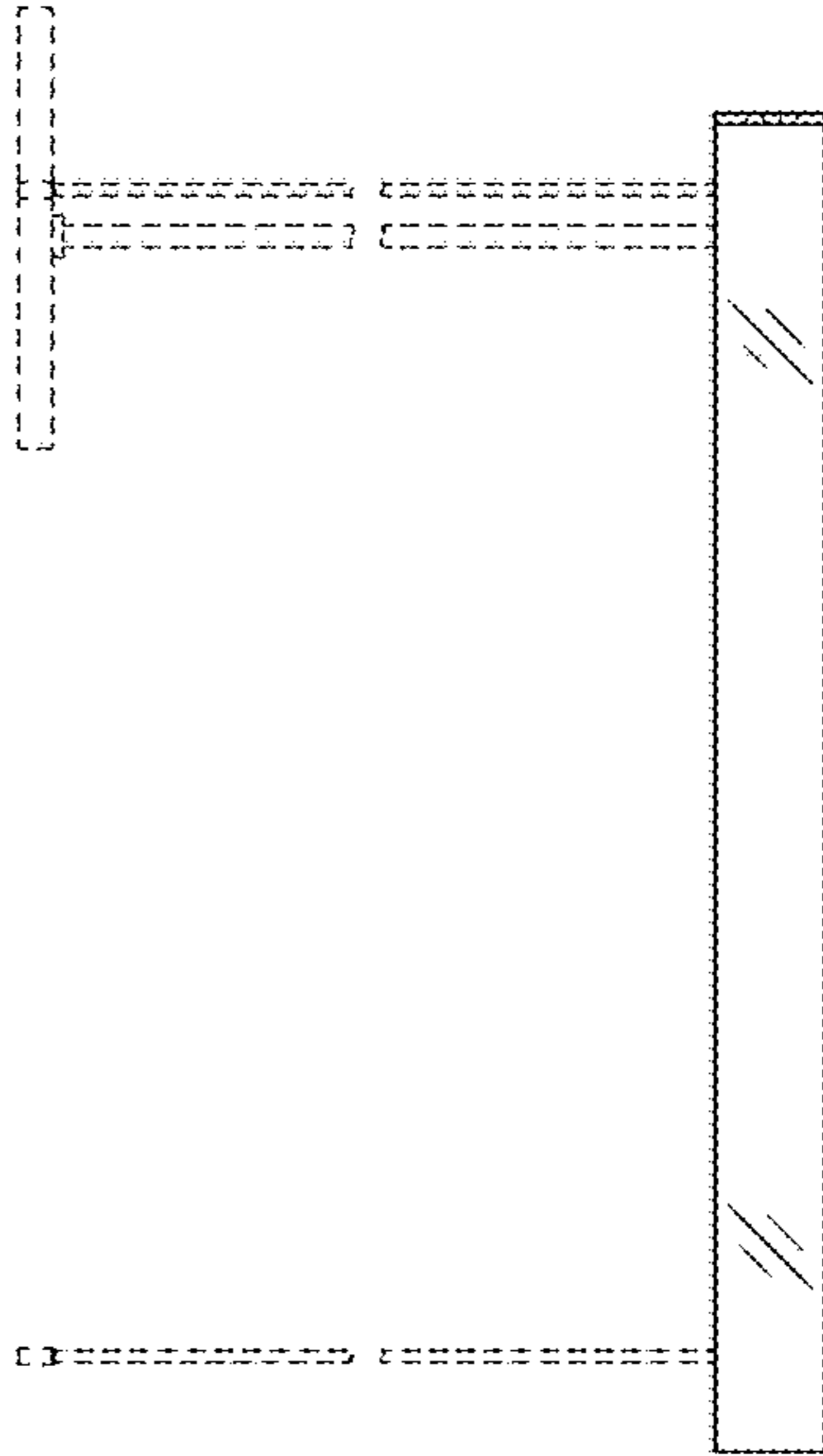

FIG. 28

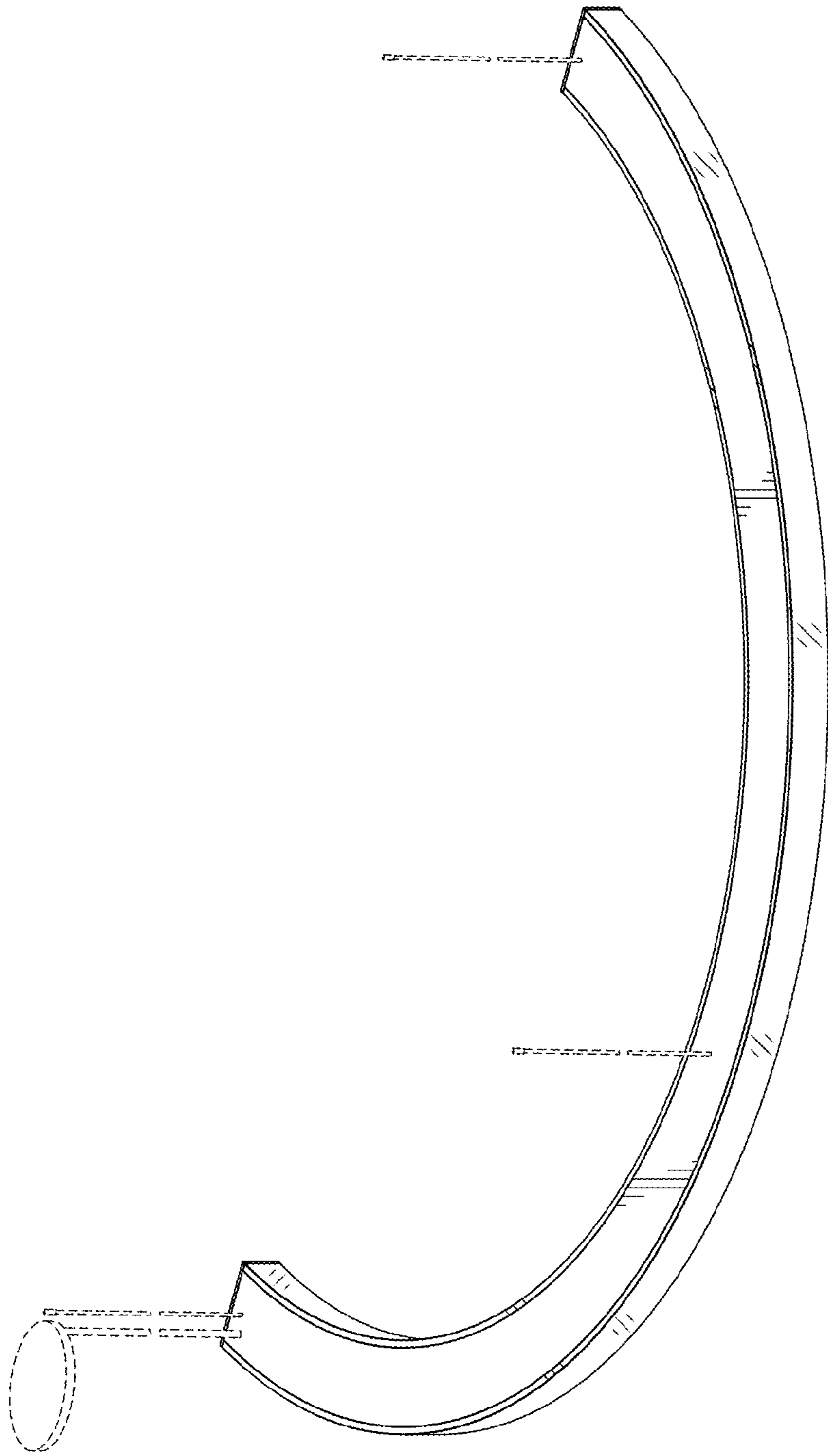

FIG. 29

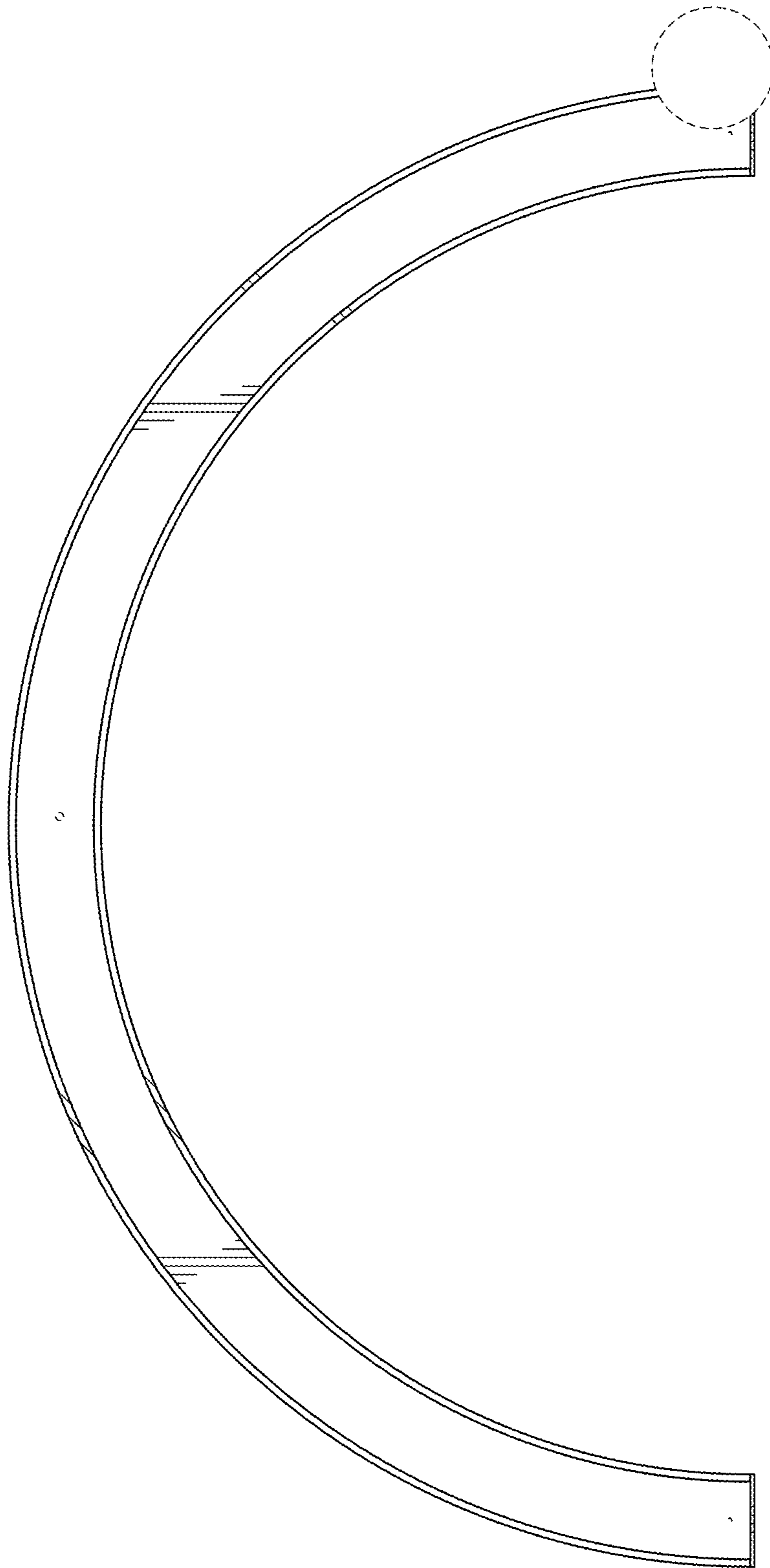

FIG. 30

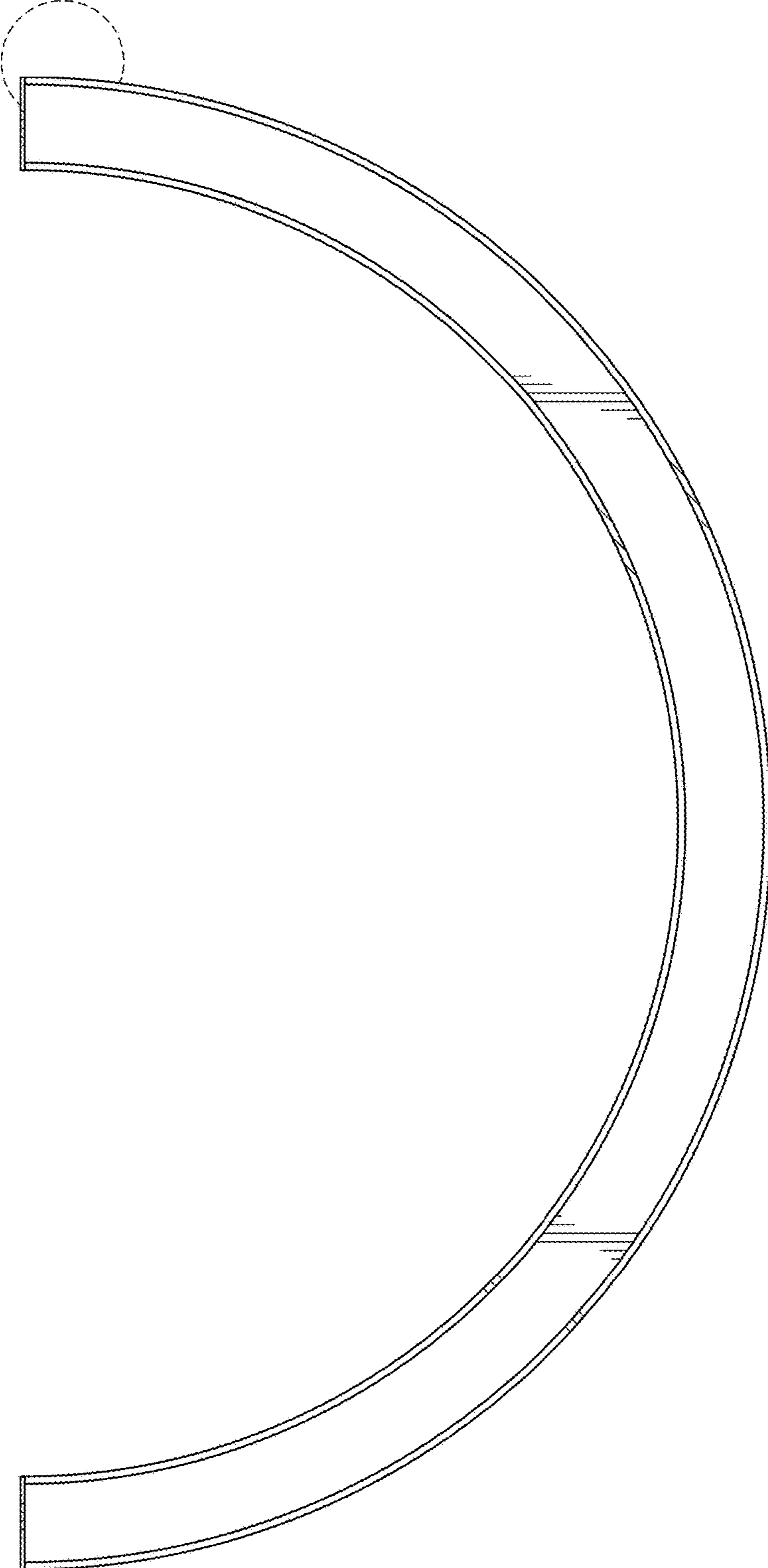

FIG. 31

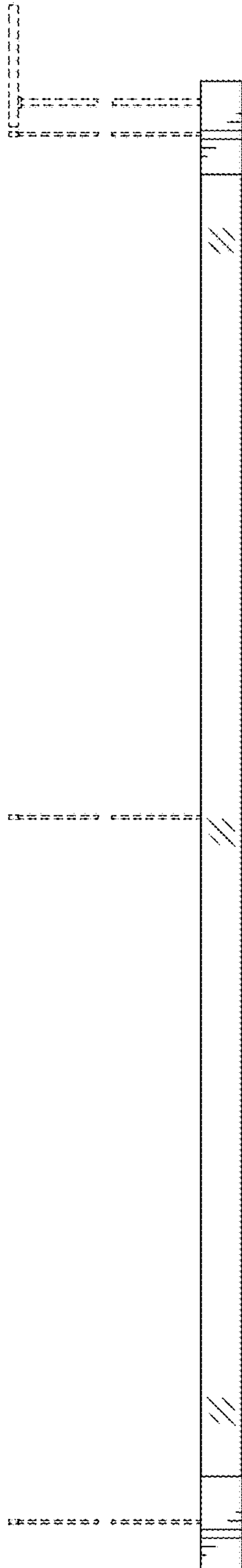

FIG. 32

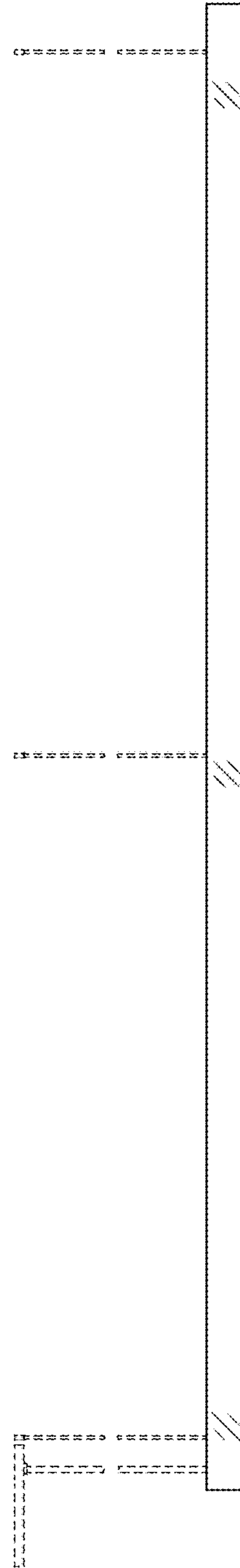

FIG. 33

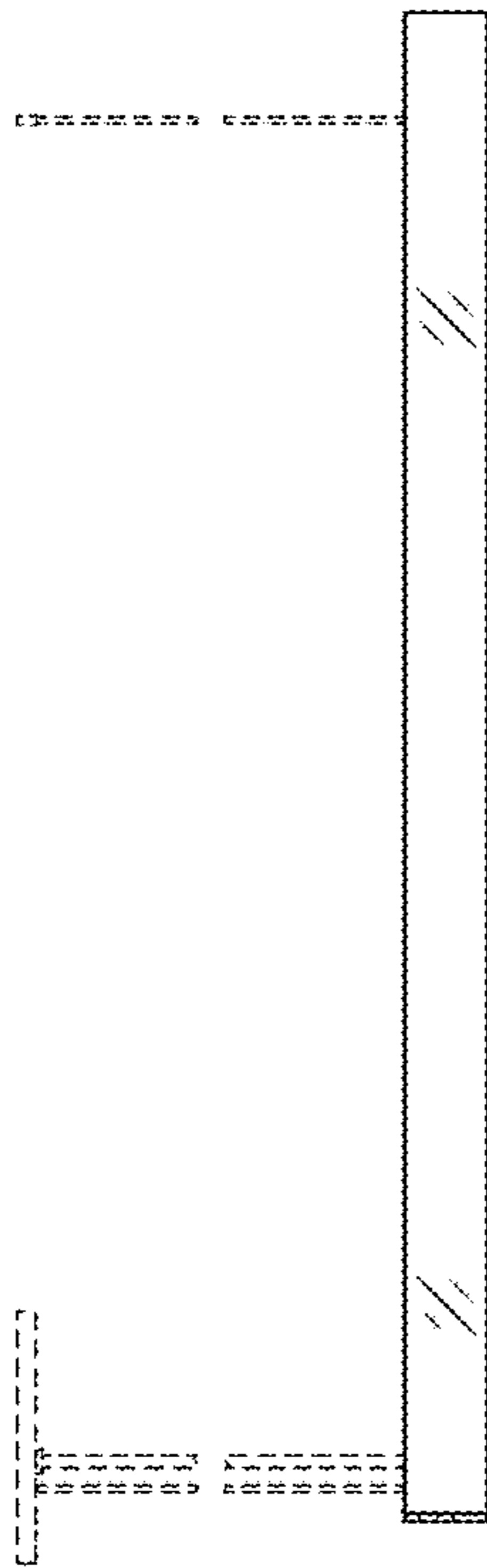

FIG. 34

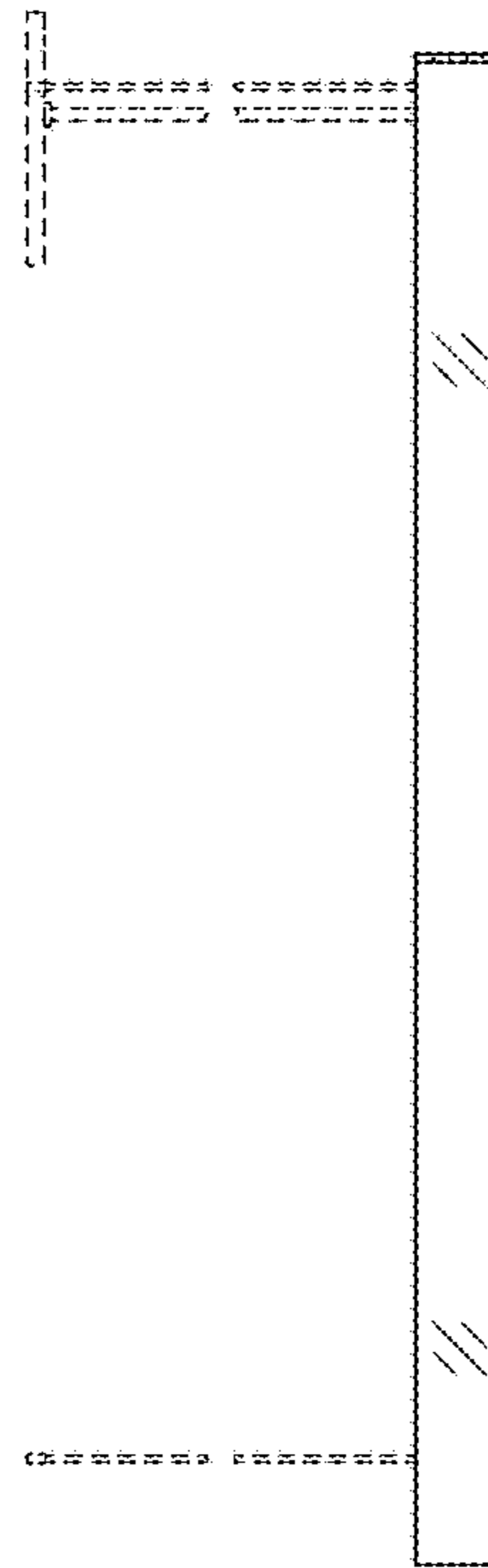

FIG. 35

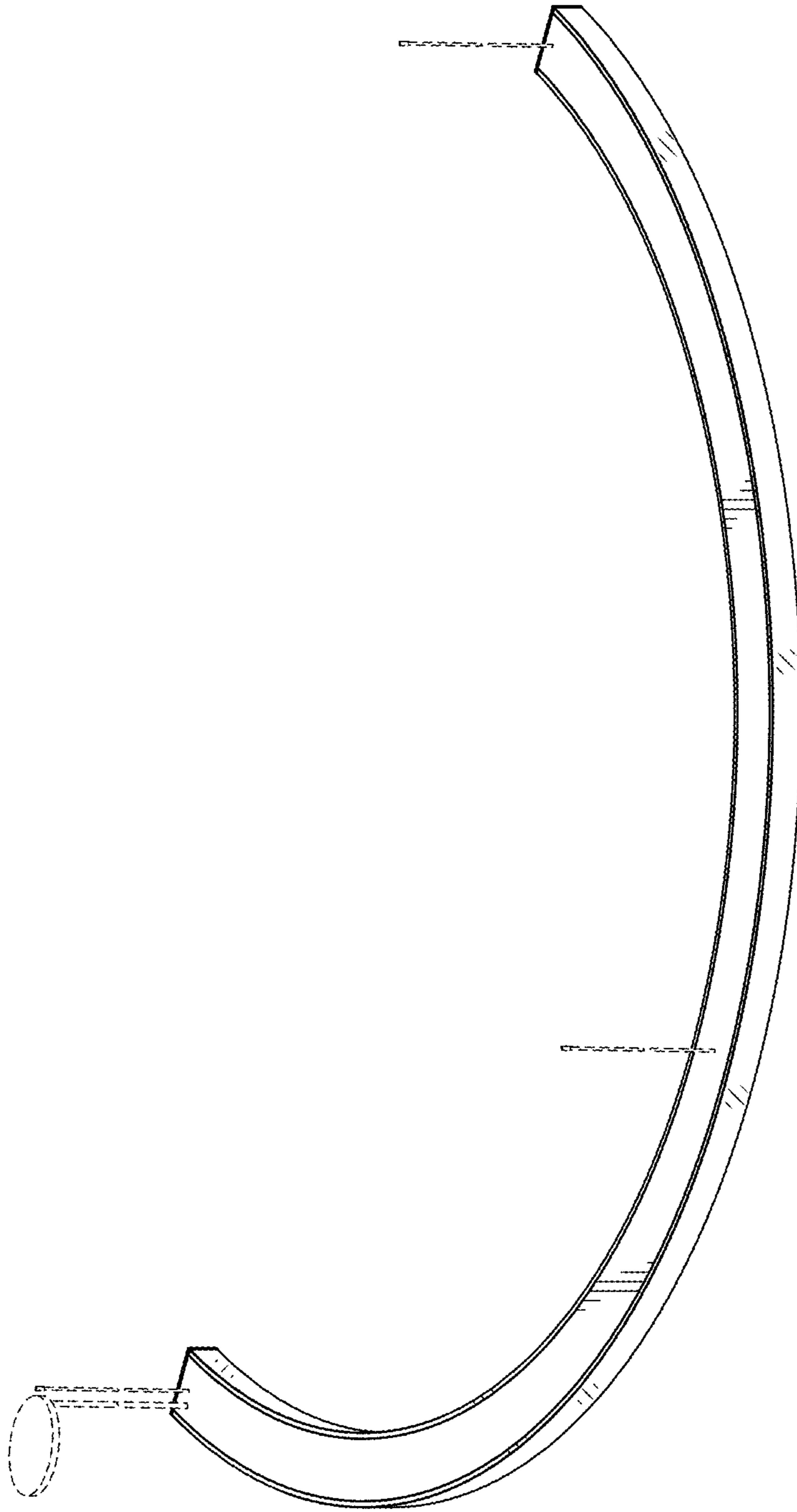

FIG. 36

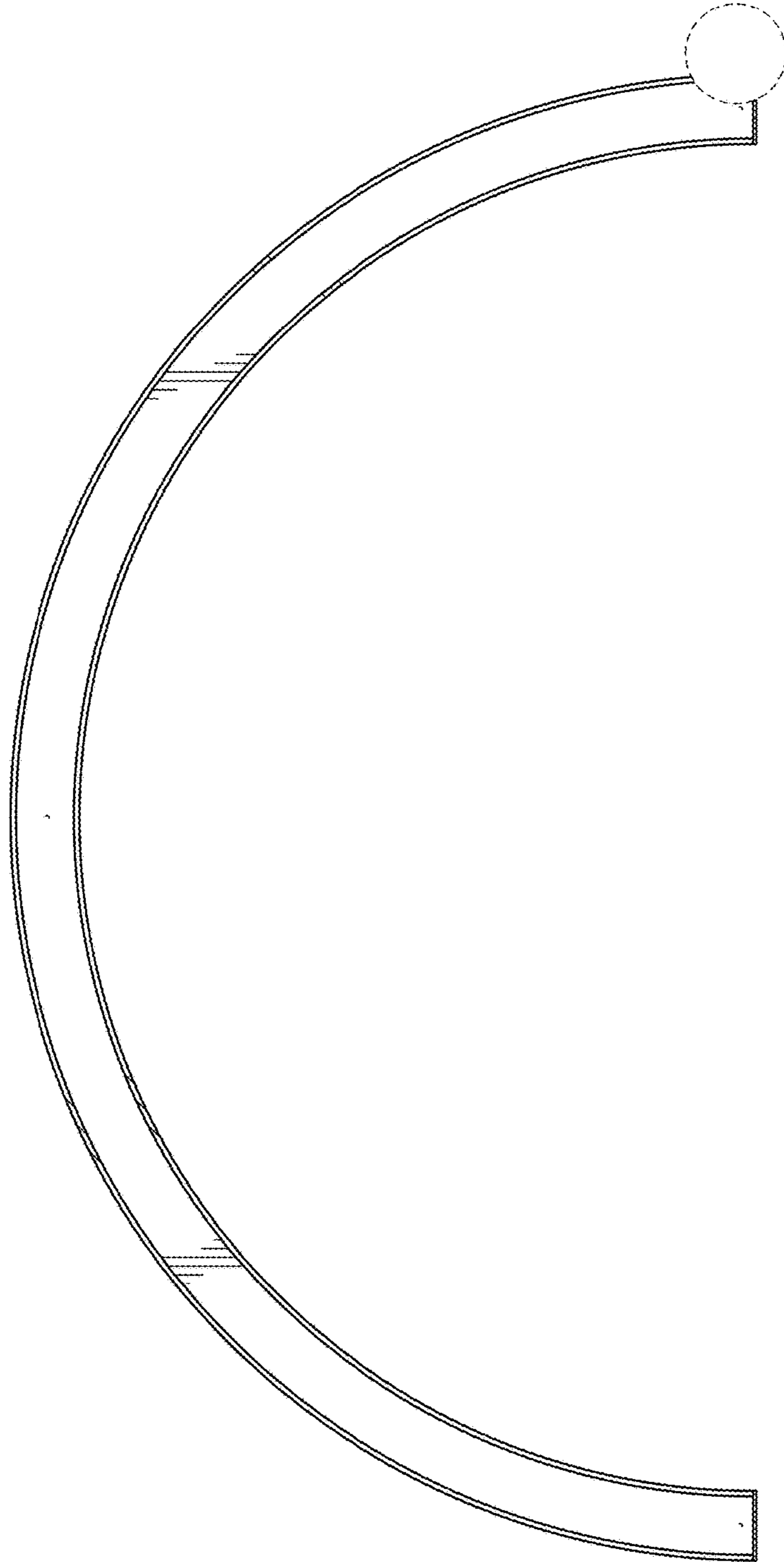

FIG. 37

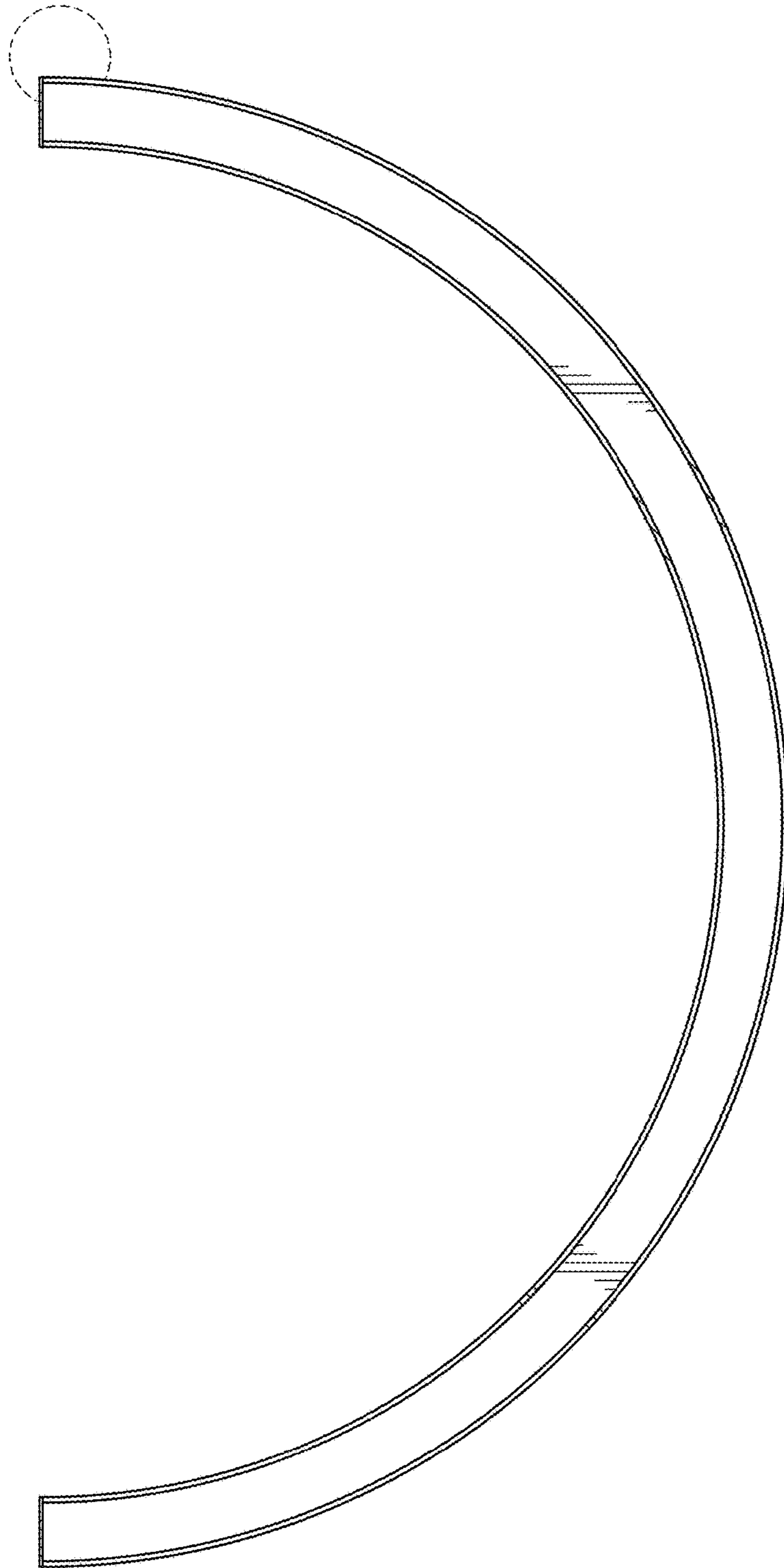

FIG. 38

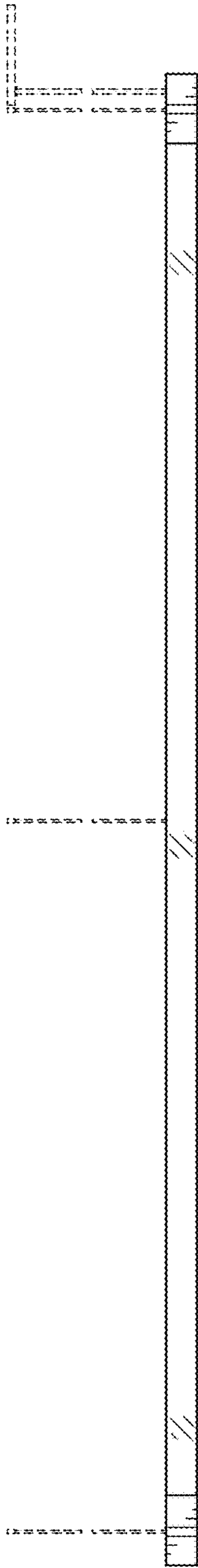

FIG. 39

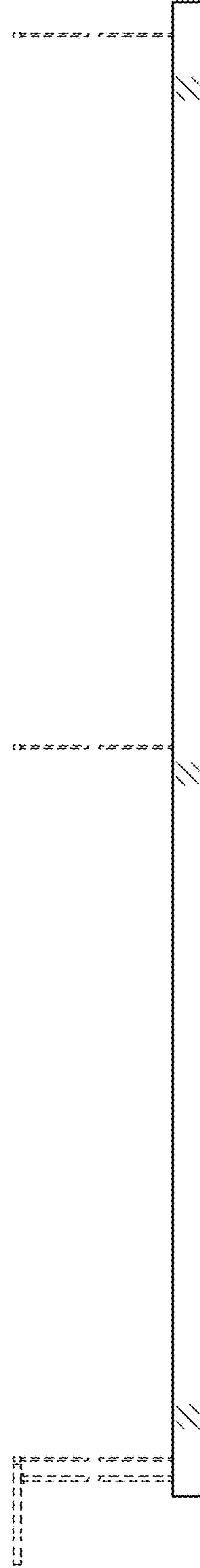

FIG. 40

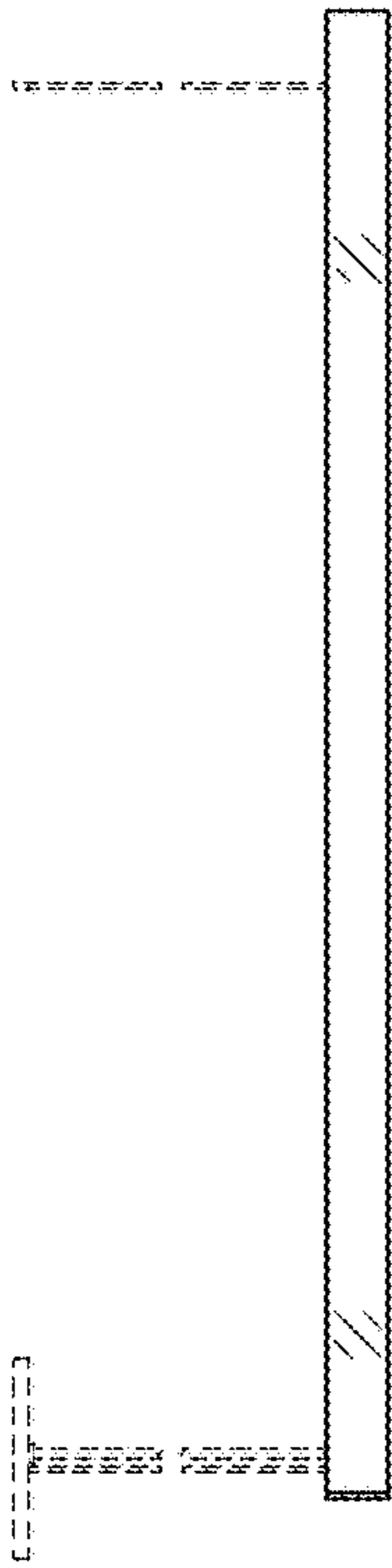

FIG. 41

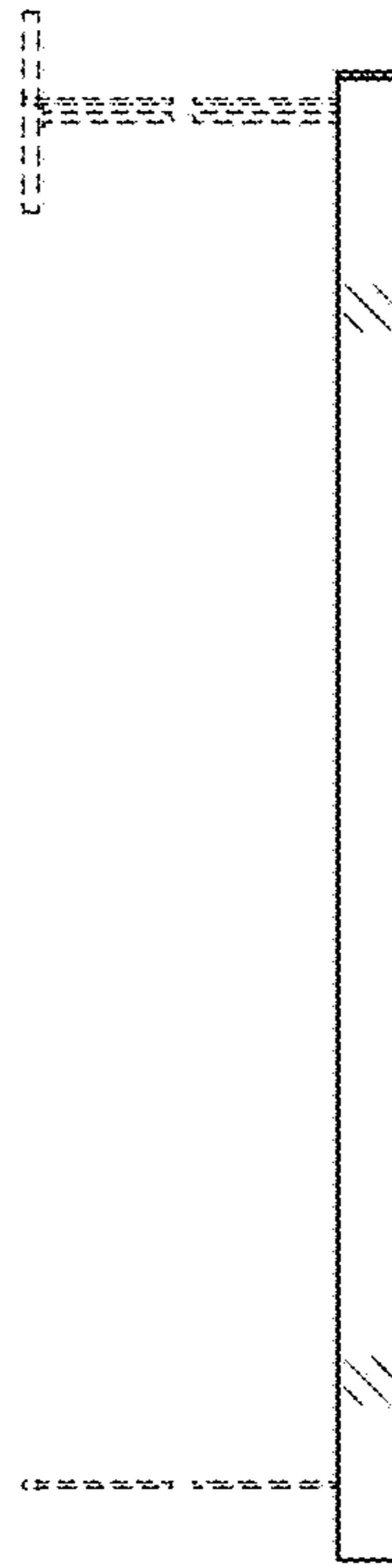

FIG. 42

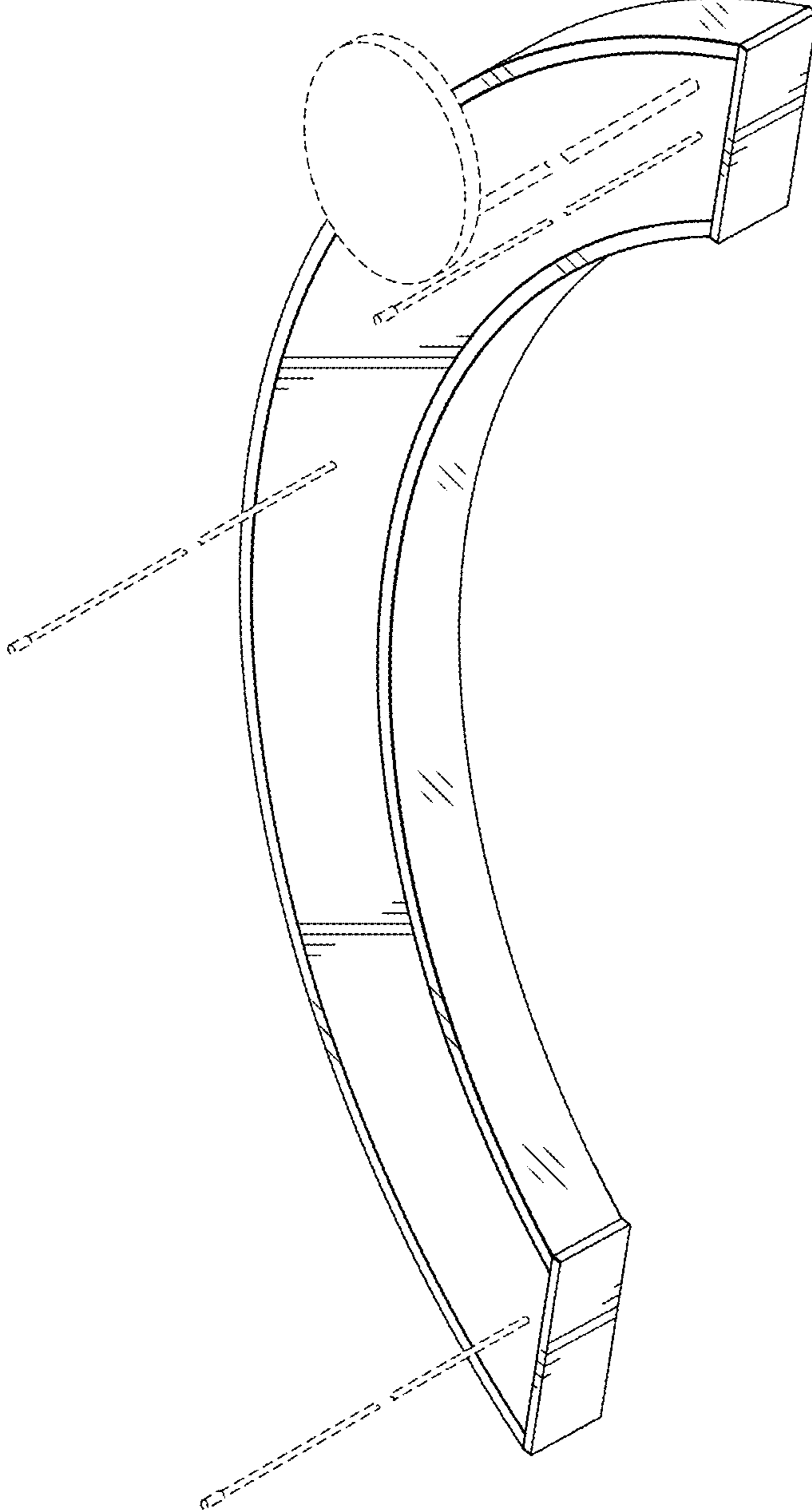

FIG. 43

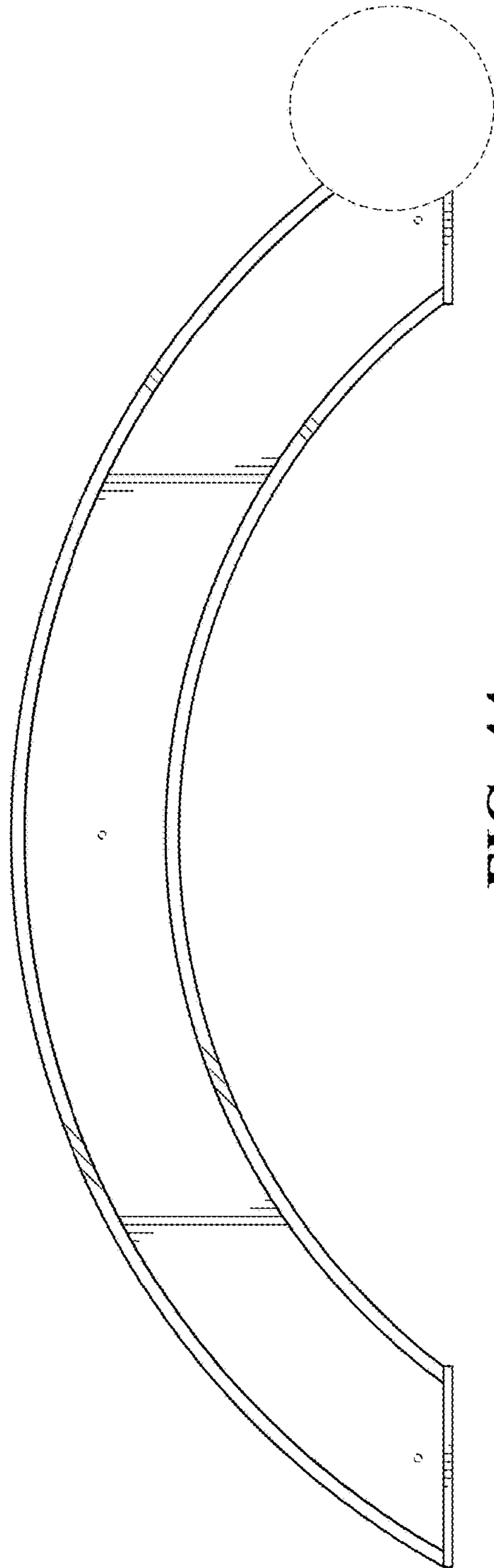

FIG. 44

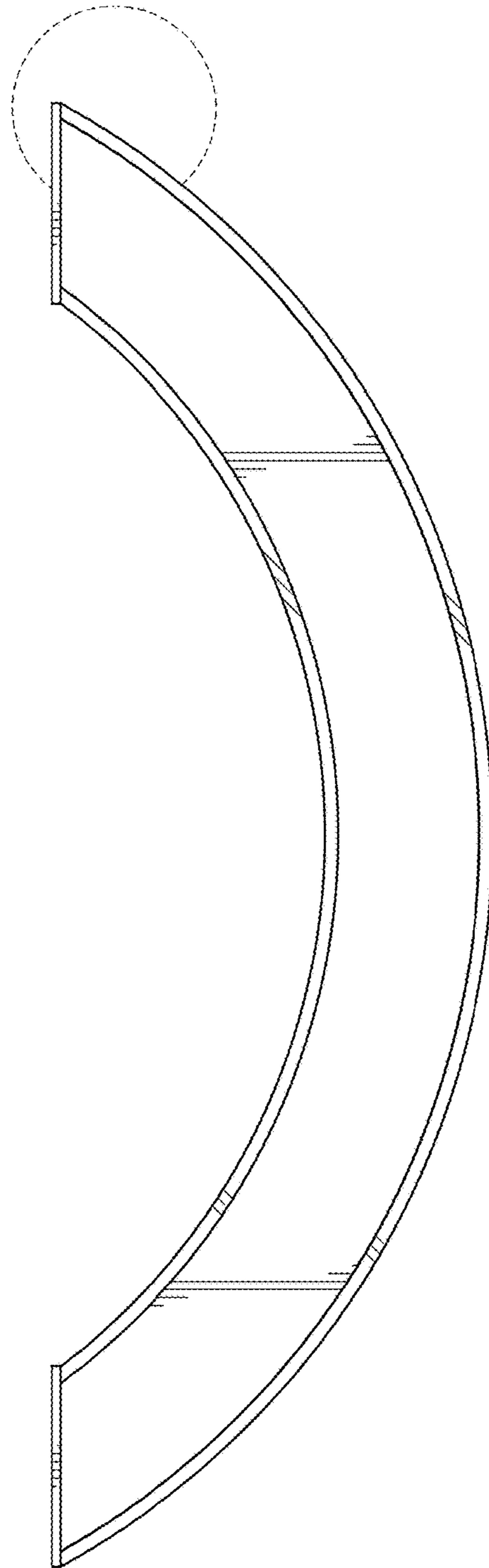

FIG. 45

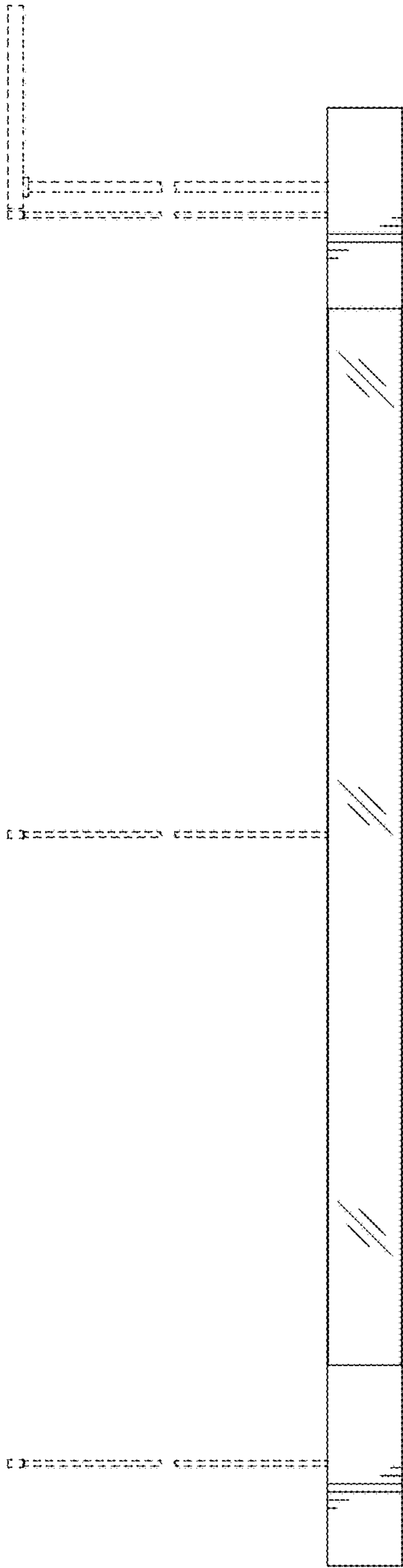

FIG. 46

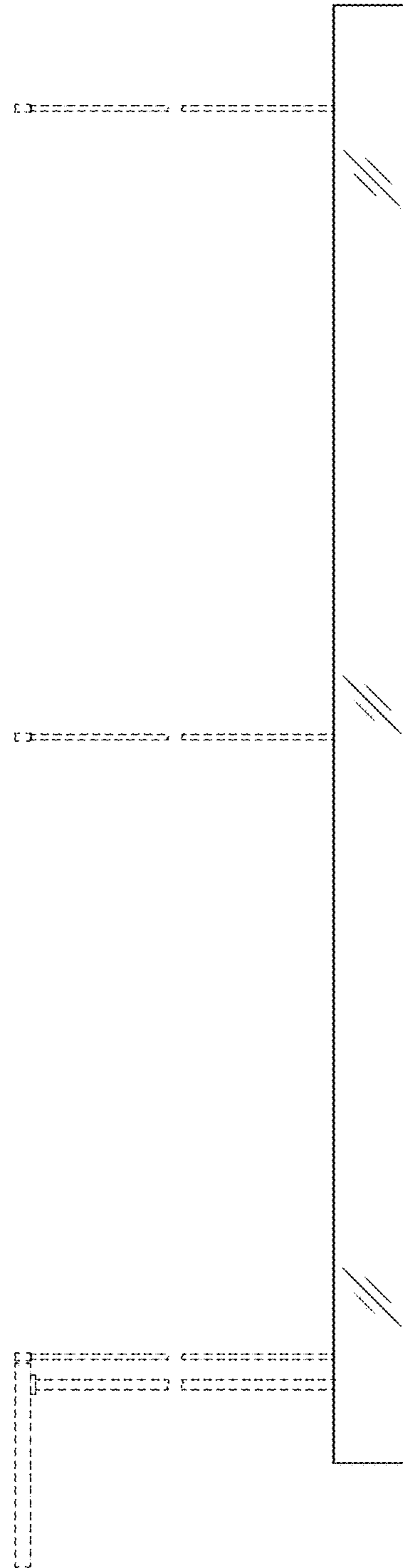

FIG. 47

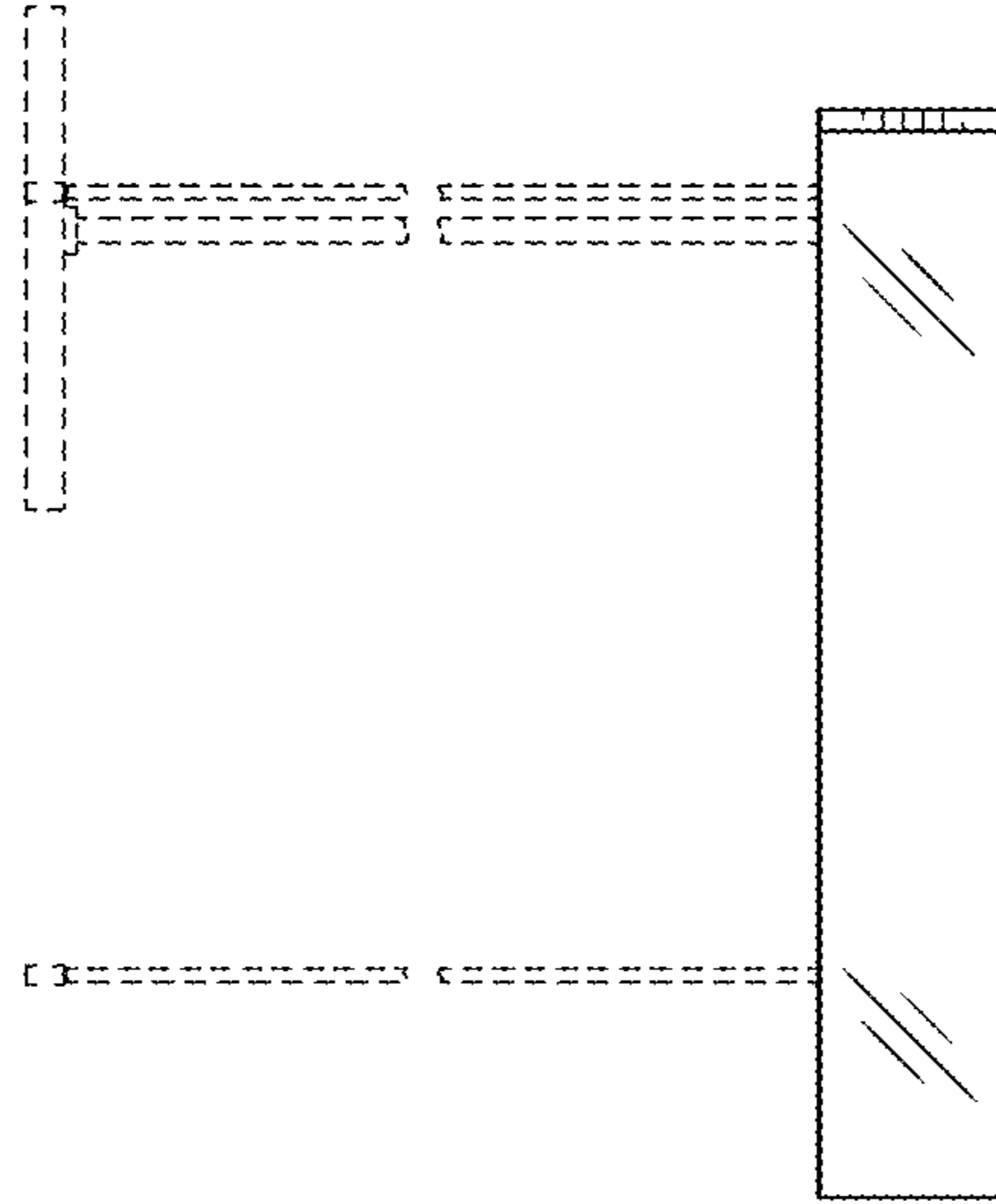

FIG. 49

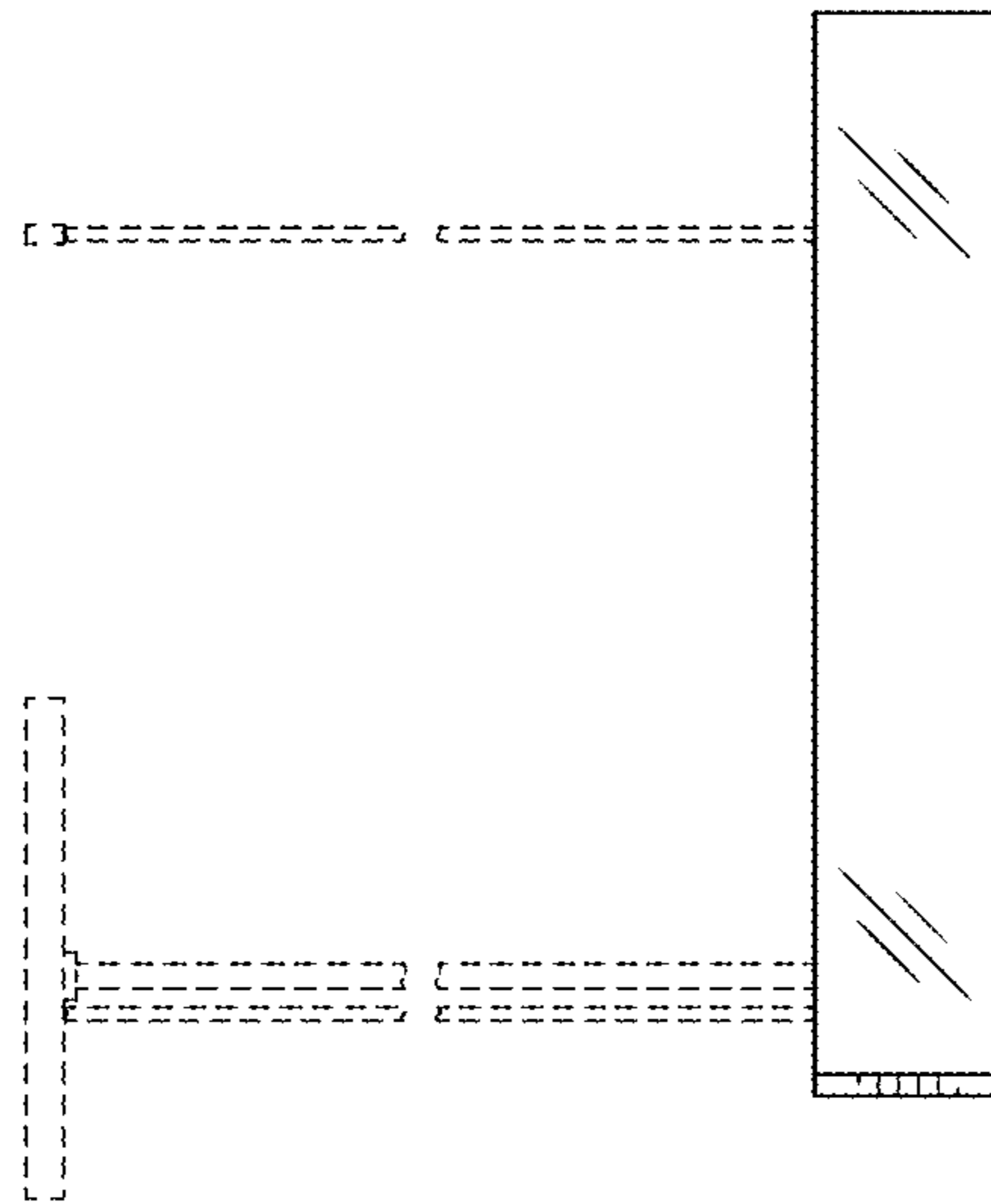

FIG. 48

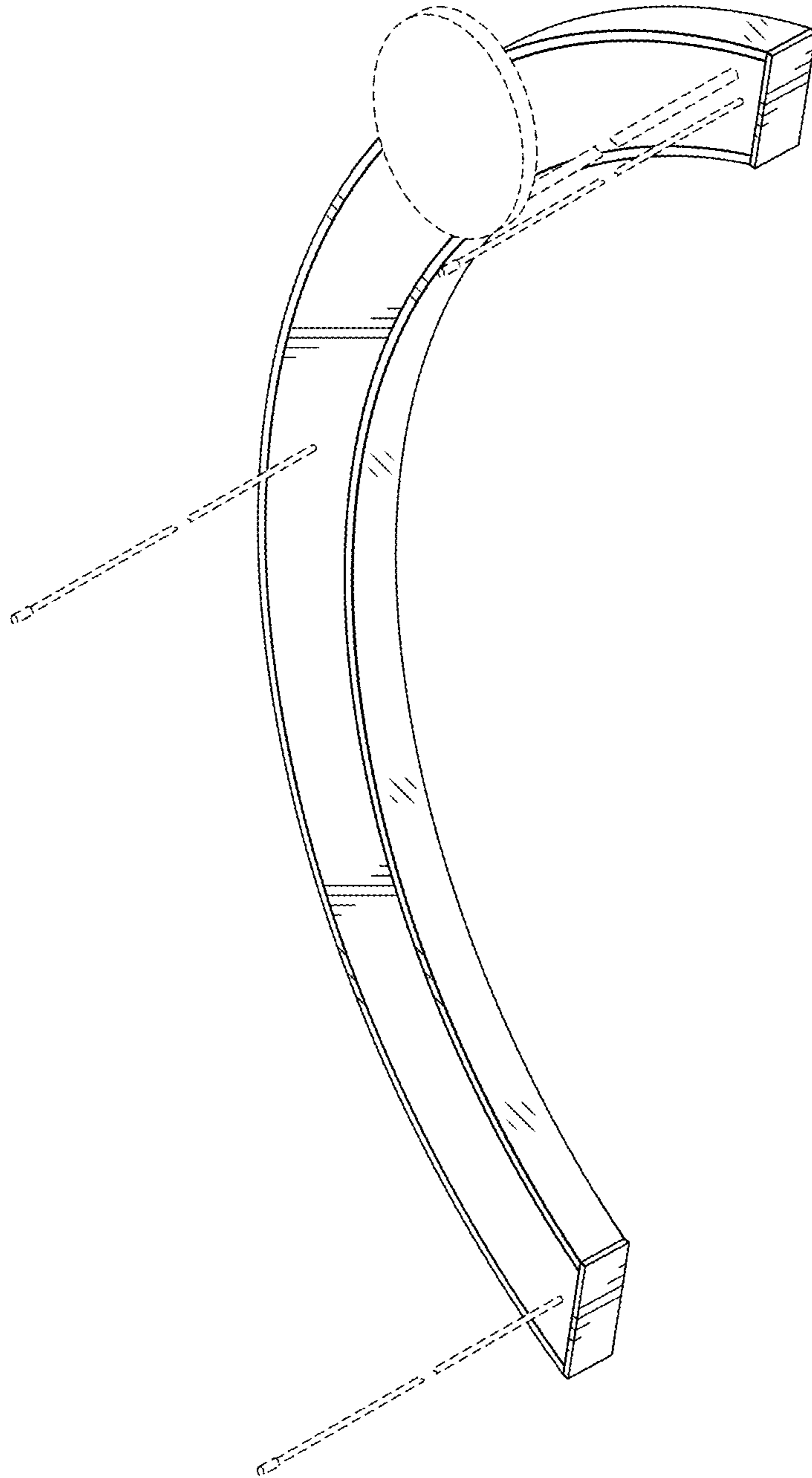

FIG. 50

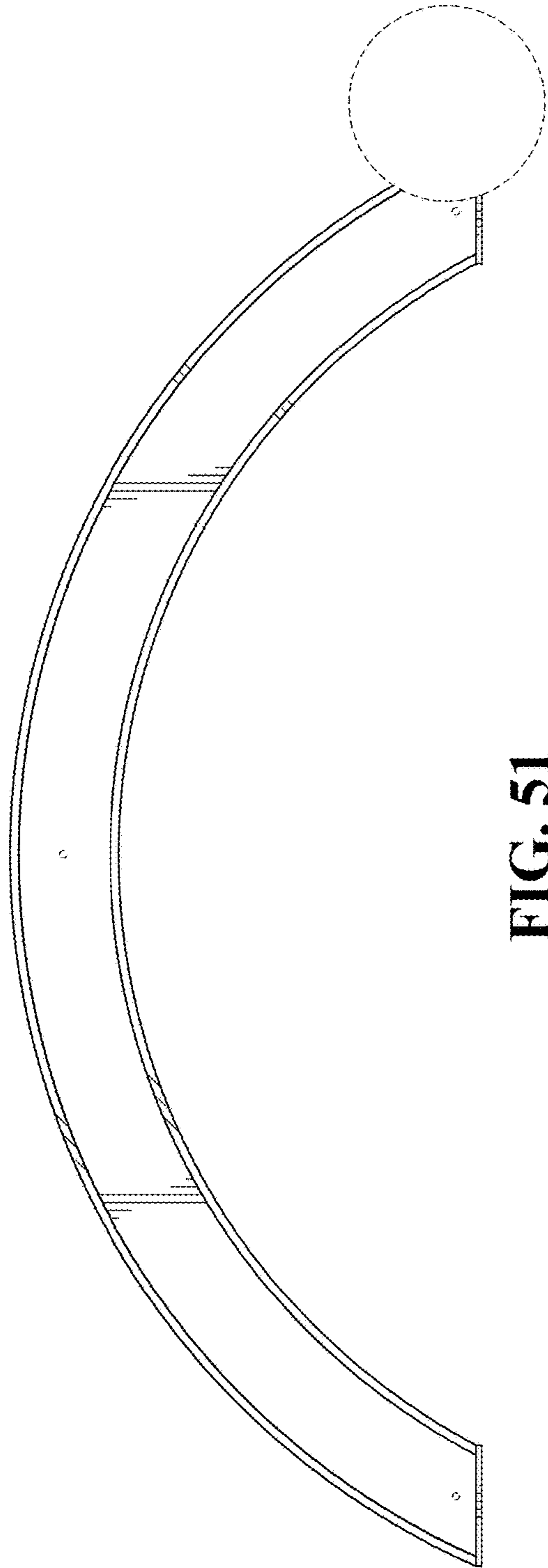

FIG. 51

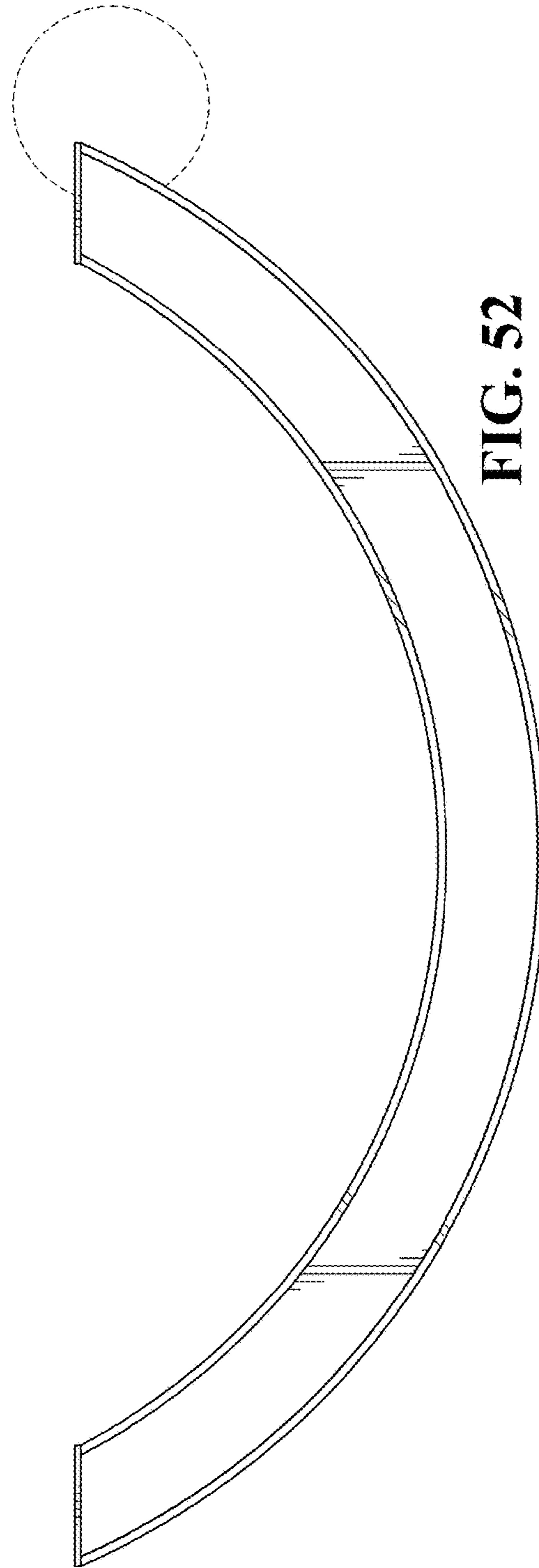

FIG. 52

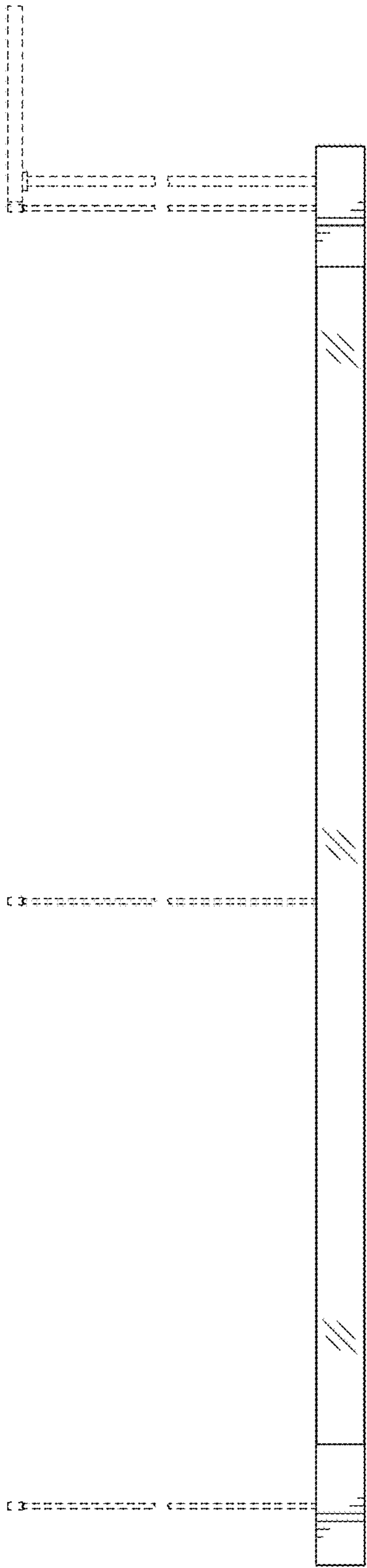

FIG. 53

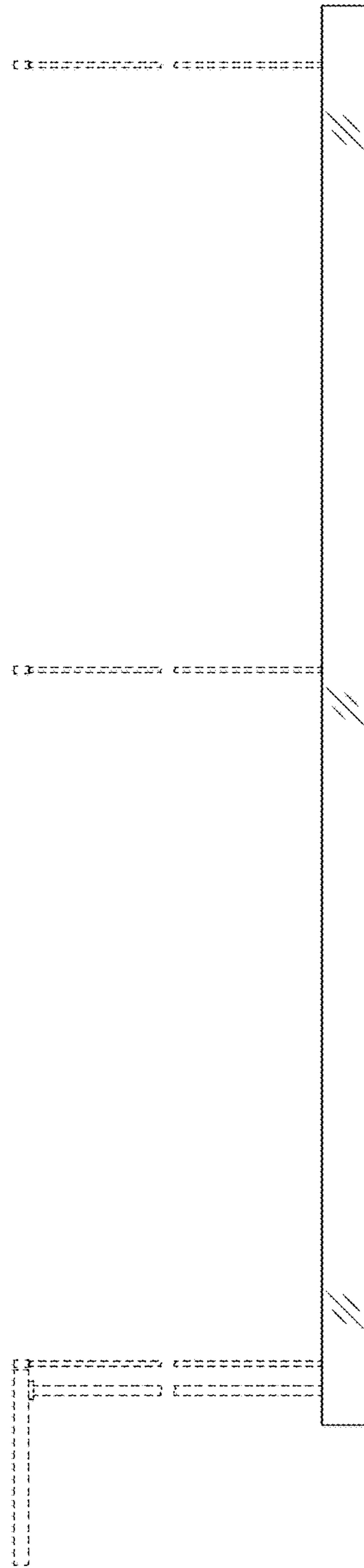

FIG. 54

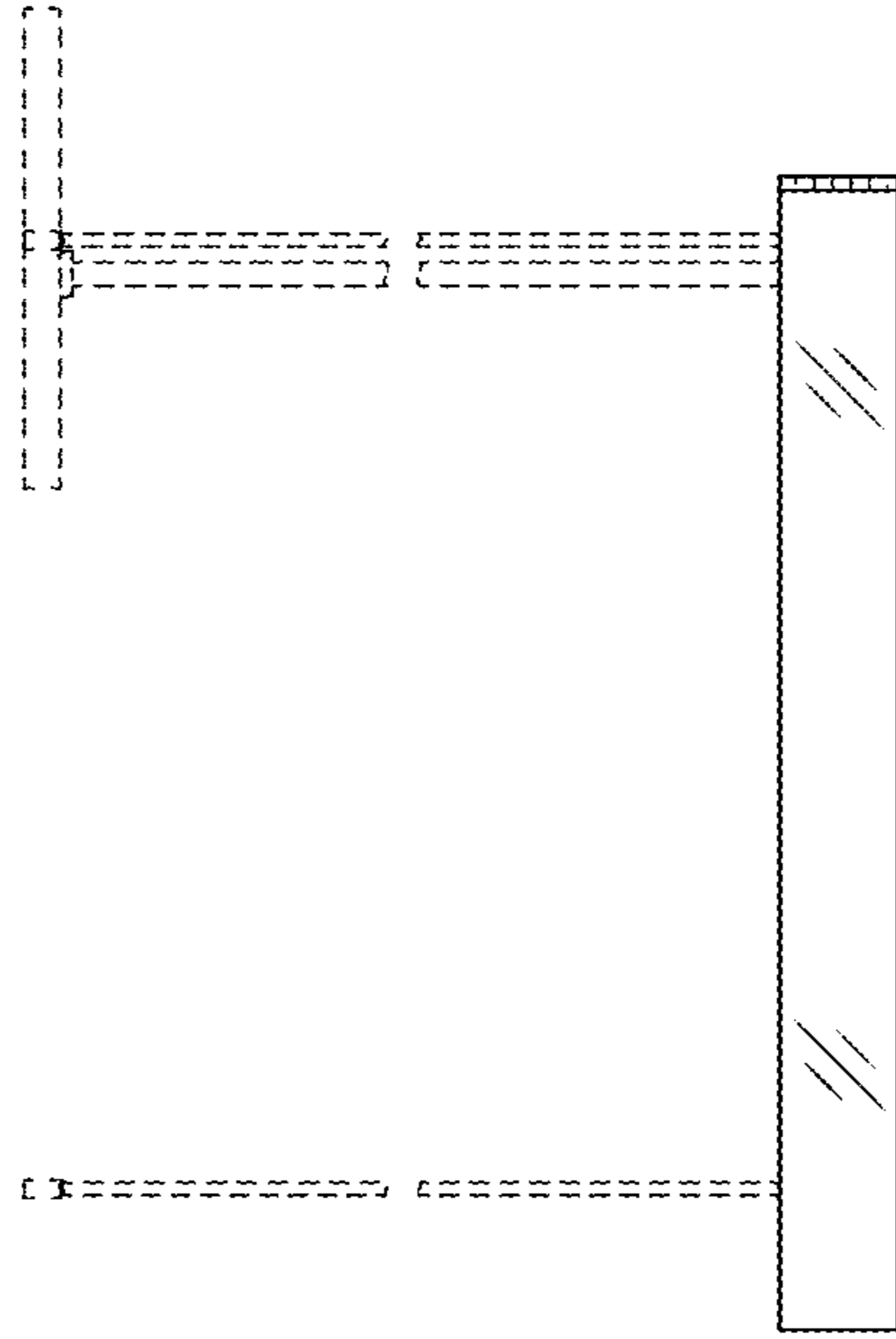

FIG. 56

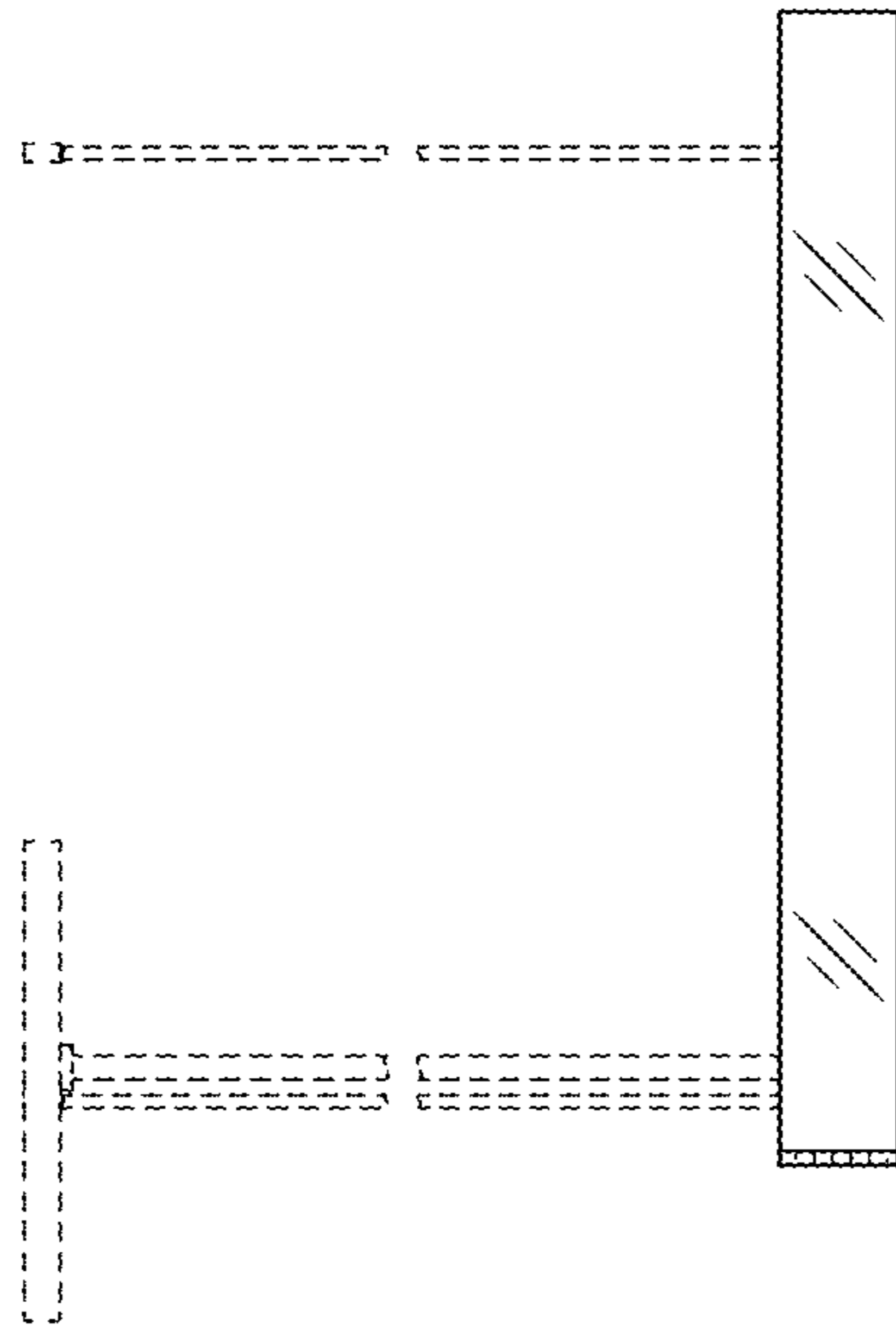

FIG. 55