



US00D828483S

(12) **United States Design Patent**
Burrow

(10) **Patent No.:** **US D828,483 S**
(45) **Date of Patent:** **** Sep. 11, 2018**

(54) **CARTRIDGE BASE INSERT**

FOREIGN PATENT DOCUMENTS

(71) Applicant: **True Velocity, Inc.**, Dallas, TX (US)

CA 2813634 A1 4/2012
DE 16742 1/1882

(72) Inventor: **Lonnie Burrow**, Carrollton, TX (US)

(Continued)

(73) Assignee: **True Velocity IP Holdings, LLC**,
Dallas, TX (US)

OTHER PUBLICATIONS

(**) Term: **15 Years**

accurateshooter.com Daily Bulletin "New PolyCase Ammunition and Injection-Molded Bullets" Jan. 11, 2015.

(21) Appl. No.: **29/591,015**

(Continued)

(22) Filed: **Jan. 16, 2017**

Primary Examiner — Michael A. Pratt

(74) *Attorney, Agent, or Firm* — Chainey P. Singleton

Related U.S. Application Data

(60) Continuation of application No. 14/748,508, filed on Jun. 24, 2015, which is a continuation of application No. 14/320,961, filed on Jul. 1, 2014, which is a continuation of application No. 14/011,202, filed on Aug. 27, 2013, now Pat. No. 9,546,849, which is a division of application No. 13/292,843, filed on Nov. 9, 2011, now Pat. No. 8,561,543.

(57) **CLAIM**

The ornamental design for a cartridge base insert, as shown and described.

(51) **LOC (11) Cl.** **22-03**

DESCRIPTION

(52) **U.S. Cl.**
USPC **D22/115**

(58) **Field of Classification Search**
USPC D22/115-116
CPC F42B 30/02; F42B 5/02; F42B 5/26; F42B 12/34; F42B 8/04; F42B 10/22; F42B 8/14; F41A 9/83; F41A 9/82; F41A 9/01; F41A 9/09; F41A 9/86
See application file for complete search history.

FIG. 1 is an isometric view of a cartridge base insert showing my new design.

FIG. 2 is a side view of a cartridge base insert showing my new design.

FIG. 3 is a side view of a cartridge base insert showing my new design.

FIG. 4 is a top view of a cartridge base insert showing my new design.

FIG. 5 is a bottom view of a cartridge base insert showing my new design.

FIG. 6 is a cross sectional view of a cartridge base insert showing my new design; and,

FIG. 7 is an isometric cross sectional view showing the cartridge base insert molded into a cartridge casing.

The broken line showing of a cartridge casing shown in FIG. 7 is included for the purpose of illustrating environment and forms no part of the claimed design.

(56) **References Cited**

U.S. PATENT DOCUMENTS

99,528 A 2/1870 Boyd
113,634 A 4/1871 Crispin
130,679 A 8/1872 Whitmore
159,665 A 2/1875 Gauthey
169,807 A 11/1875 Hart
462,611 A 11/1891 Comte De Sparre

(Continued)

1 Claim, 5 Drawing Sheets

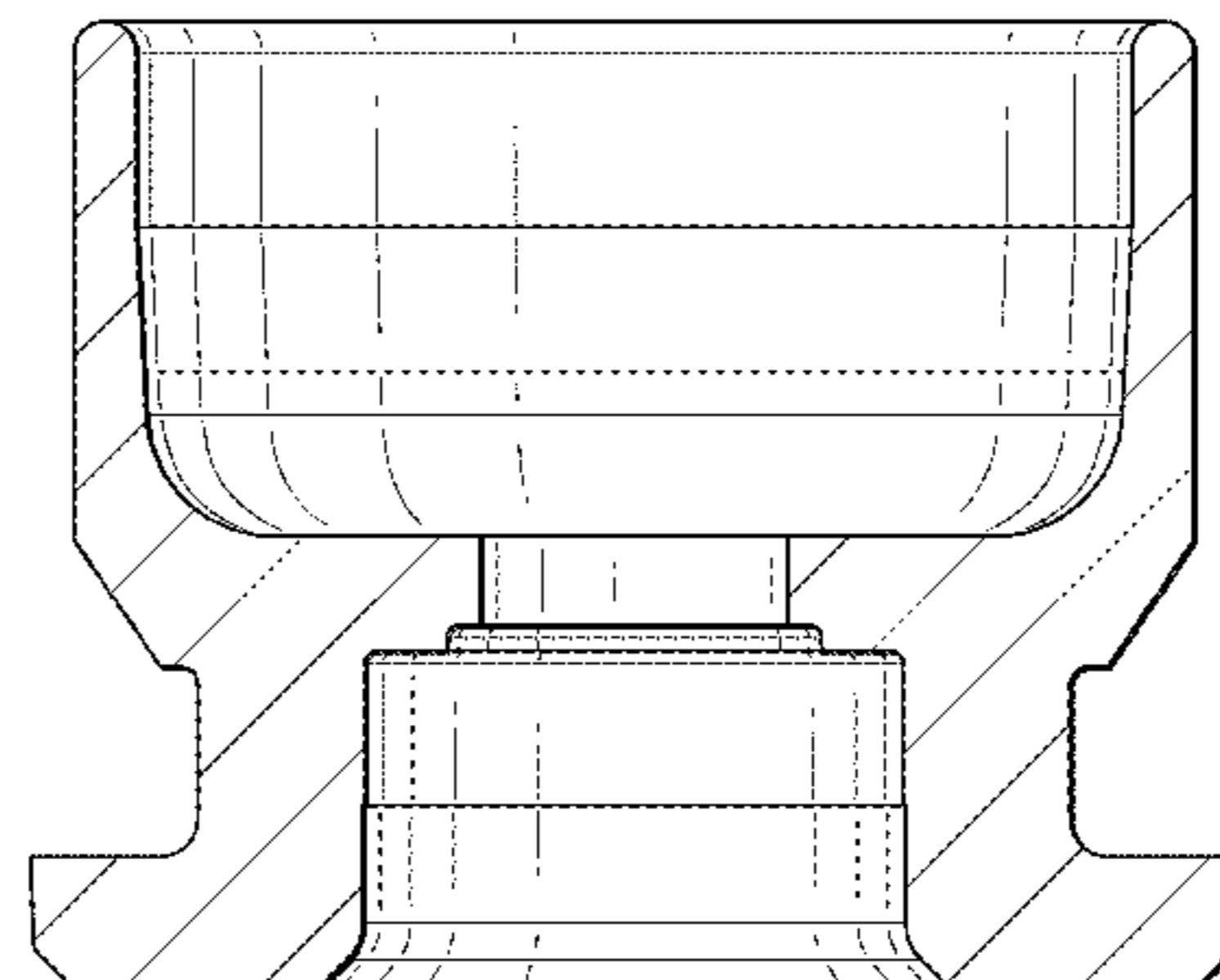
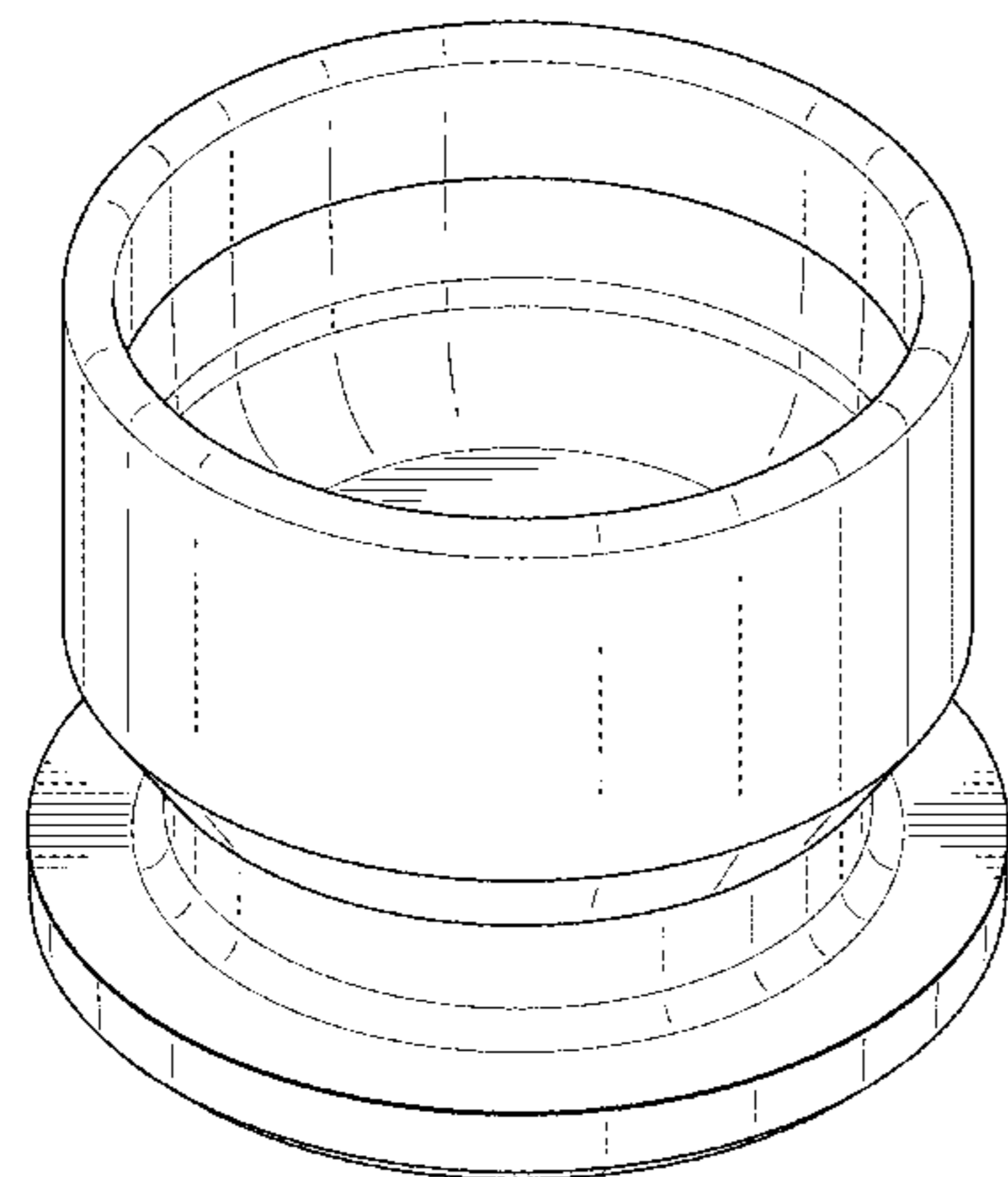

(56)

References Cited

U.S. PATENT DOCUMENTS

498,856	A	6/1893	Overbaugh	6,283,035	B1	9/2001	Olson et al.
640,856	A	1/1900	Bailey	6,357,357	B1	3/2002	Glasser
662,137	A	11/1900	Tellerson	6,375,971	B1	4/2002	Hansen
676,000	A	6/1901	Henneberg	6,450,099	B1	9/2002	Desglan
865,979	A	9/1907	Bailey	6,460,464	B1	10/2002	Attarwala
869,046	A	10/1907	Bailey	6,523,476	B1	2/2003	Riess et al.
905,358	A	12/1908	Peters	6,649,095	B2	11/2003	Buja
957,171	A	5/1910	Loeb	6,708,621	B1	3/2004	Forichon-Chaumet et al.
963,911	A	7/1910	Loeble	6,752,084	B1	6/2004	Husseini et al.
1,060,817	A	5/1913	Clyne	6,840,149	B2	1/2005	Beal
1,940,657	A	12/1933	Woodford	6,845,716	B2	1/2005	Husseini et al.
2,294,822	A	9/1940	Norman	7,000,547	B2	2/2006	Amick
2,465,962	A	3/1949	Allen et al.	7,032,492	B2	4/2006	Meshirer
2,654,319	A	10/1953	Roske	7,056,091	B2	6/2006	Powers
2,823,611	A	2/1958	Thayer	7,059,234	B2	6/2006	Husseini
2,862,446	A	12/1958	Ringdal	7,165,496	B2	1/2007	Reynolds
2,918,868	A	12/1959	Lars	7,204,191	B2	4/2007	Wiley et al.
3,099,958	A	8/1963	Daubenspeck	7,213,519	B2	5/2007	Wiley et al.
3,170,401	A	2/1965	Johnson et al.	7,232,473	B2	6/2007	Elliott
3,242,789	A	3/1966	Woodring	7,299,750	B2	11/2007	Schikora et al.
3,292,538	A	12/1966	Umbach et al.	7,353,756	B2	4/2008	Leasure
3,485,170	A	12/1969	Scanlon	7,380,505	B1	6/2008	Shiery
3,485,173	A	12/1969	Morgan	7,383,776	B2	6/2008	Amick
3,609,904	A	10/1971	Scanlon	7,392,746	B2	7/2008	Hansen
3,659,528	A	5/1972	Santala	7,441,504	B2	10/2008	Husseini et al.
3,688,699	A	9/1972	Horn et al.	7,585,166	B2	9/2009	Buja
3,690,256	A	9/1972	Schnitzer	7,610,858	B2	11/2009	Chung
3,745,924	A	7/1973	Scanlon	7,750,091	B2	7/2010	Maljkovic et al.
3,749,021	A	7/1973	Burgess	7,841,279	B2	11/2010	Reynolds et al.
3,756,156	A	9/1973	Schuster	7,930,977	B2	4/2011	Klein
3,765,297	A	10/1973	Skochko	8,007,370	B2	8/2011	Hirsch et al.
3,768,413	A	10/1973	Ramsay	8,056,232	B2	11/2011	Patel et al.
3,797,396	A	3/1974	Reed	8,156,870	B2	4/2012	South
3,842,739	A	10/1974	Scanlon et al.	8,201,867	B2	6/2012	Thomeczek
3,866,536	A	2/1975	Greenberg	8,206,522	B2	6/2012	Sandstrom et al.
3,874,294	A	4/1975	Hale	8,240,252	B2	8/2012	Maljkovic et al.
3,955,506	A	5/1976	Luther et al.	8,408,137	B2	4/2013	Battaglia
3,977,326	A	8/1976	Anderson et al.	8,443,730	B2	5/2013	Padgett
3,990,366	A	11/1976	Scanlon	8,511,233	B2	8/2013	Nilsson
4,020,763	A	5/1977	Iruetagoyena	8,522,684	B2	9/2013	Davies et al.
4,147,107	A	4/1979	Ringdal	8,540,828	B2	9/2013	Busky et al.
4,157,684	A	6/1979	Clausser	8,561,543	B2	10/2013	Burrow
4,173,186	A	11/1979	Dunham	8,573,126	B2	11/2013	Klein et al.
4,187,271	A	2/1980	Rolston et al.	8,641,842	B2	2/2014	Hafner et al.
4,228,724	A	10/1980	Leich	8,689,696	B1	4/2014	Seeman et al.
4,475,435	A	10/1984	Mantel	8,763,535	B2	7/2014	Padgett
4,598,445	A	7/1986	O'Connor	8,790,455	B2	7/2014	Borissov et al.
4,614,157	A	9/1986	Grelle et al.	8,807,008	B2	8/2014	Padgett et al.
4,679,505	A	7/1987	Reed	8,813,650	B2	8/2014	Maljkovic et al.
4,718,348	A	1/1988	Ferrigno	D715,888	S	10/2014	Padgett
4,719,859	A	1/1988	Ballreich et al.	8,857,343	B2	10/2014	Marx
4,726,296	A	2/1988	Leshner et al.	8,869,702	B2	10/2014	Padgett
4,867,065	A	9/1989	Kaltmann et al.	8,875,633	B2	11/2014	Padgett
5,021,206	A	6/1991	Stoops	8,893,621	B1	11/2014	Escobar
5,033,386	A	7/1991	Vatsvog	8,978,559	B2	3/2015	Davies et al.
5,063,853	A	11/1991	Bilgeri	9,003,973	B1	4/2015	Padgett
5,090,327	A	2/1992	Bilgeri	9,032,855	B1	5/2015	Foren et al.
5,151,555	A	9/1992	Vatsvog	9,091,516	B2	7/2015	Davies et al.
5,165,040	A	11/1992	Andersson et al.	9,103,641	B2	8/2015	Nielson et al.
5,237,930	A	8/1993	Belanger et al.	9,170,080	B2	10/2015	Poore et al.
5,247,888	A	9/1993	Conil	9,182,204	B2	11/2015	Maljkovic et al.
5,259,288	A	11/1993	Vatsvog	9,200,880	B1	12/2015	Foren et al.
5,265,540	A	11/1993	Ducros et al.	9,212,876	B1	12/2015	Kostka et al.
5,433,148	A	7/1995	Barratault et al.	9,212,879	B2	12/2015	Whitworth
5,535,495	A	7/1996	Gutowski	9,213,175	B2	12/2015	Arnold
5,563,365	A	10/1996	Dineen et al.	9,254,503	B2	2/2016	Ward
5,770,815	A	6/1998	Watson	9,255,775	B1	2/2016	Rubin
5,798,478	A	8/1998	Beal	9,329,004	B2	5/2016	Pace
5,950,063	A	9/1999	Hens et al.	9,335,137	B2	5/2016	Maljkovic et al.
5,961,200	A	10/1999	Friis	9,337,278	B1	5/2016	Gu et al.
5,969,288	A	10/1999	Baud	9,347,457	B2	5/2016	Ahrens et al.
6,004,682	A	12/1999	Rackovan et al.	9,366,512	B2	6/2016	Burczynski et al.
6,048,379	A	4/2000	Bray et al.	9,377,278	B2	6/2016	Rubin
6,070,532	A	6/2000	Halverson	9,389,052	B2	7/2016	Conroy et al.
6,272,993	B1	8/2001	Cook et al.	9,395,165	B2	7/2016	Maljkovic et al.
				D764,624	S	8/2016	Masinelli
				D765,214	S	8/2016	Padgett
				9,429,407	B2	8/2016	Burrow
				9,441,930	B2	9/2016	Burrow

(56)

References Cited

U.S. PATENT DOCUMENTS

9,453,714 B2 9/2016 Bosarge et al.
 9,528,799 B2 12/2016 Maljkovic
 D778,391 S 2/2017 Burrow
 D778,393 S 2/2017 Burrow
 D778,394 S 2/2017 Burrow
 D778,395 S 2/2017 Burrow
 D779,021 S * 2/2017 Burrow D22/115
 D779,024 S 2/2017 Burrow
 D781,393 S * 3/2017 Burrow D22/115
 D783,765 S * 4/2017 MacTavish, Sr. D22/116
 9,835,427 B2 * 12/2017 Burrow F42C 19/083
 9,885,551 B2 * 2/2018 Burrow F42B 5/307
 2001/0013299 A1 8/2001 Husseini et al.
 2002/0084543 A1 7/2002 Buja
 2003/0101891 A1 6/2003 Amick
 2003/0217665 A1 11/2003 Rennard
 2004/0159262 A1 8/2004 LeaSure
 2005/0005807 A1 1/2005 Wiley et al.
 2005/0016411 A1 1/2005 Amick
 2005/0056183 A1 3/2005 Meshirer
 2005/0188883 A1 9/2005 Husseini et al.
 2005/0257711 A1 11/2005 Husseini et al.
 2005/0257712 A1 11/2005 Husseini et al.
 2005/0268808 A1 12/2005 Werner
 2006/0027129 A1 2/2006 Kolb et al.
 2006/0207464 A1 9/2006 Maljkovic et al.
 2006/0283314 A1 12/2006 Cesaroni
 2007/0214992 A1 9/2007 Dittrich
 2007/0261587 A1 11/2007 Chung
 2009/0042057 A1 2/2009 Thomas et al.
 2009/0183850 A1 7/2009 Morrison et al.
 2010/0016518 A1 1/2010 El-Hibri et al.
 2010/0258023 A1 10/2010 Reynolds et al.
 2010/0300319 A1 12/2010 Guindon
 2010/0305261 A1 12/2010 Maljkovic et al.
 2011/0016717 A1 1/2011 Morrison et al.
 2011/0179965 A1 7/2011 Mason
 2011/0226149 A1 9/2011 Tape et al.
 2012/0024183 A1 2/2012 Klein
 2012/0111219 A1 5/2012 Burrow
 2012/0152101 A1 6/2012 Engleman et al.
 2012/0180687 A1 7/2012 Padgett et al.
 2012/0180688 A1 7/2012 Padgett
 2013/0014664 A1 1/2013 Padgett
 2013/0180392 A1 7/2013 Nuetzman et al.
 2013/0186294 A1 7/2013 Davies et al.
 2014/0060372 A1 3/2014 Padgett
 2014/0060373 A1 3/2014 Maljkovic et al.
 2014/0076188 A1 3/2014 Maljkovic et al.
 2014/0216293 A1 8/2014 Klein et al.
 2014/0224144 A1 8/2014 Neugebauer
 2014/0235784 A1 8/2014 Maljkovic et al.
 2014/0260925 A1 9/2014 Beach et al.
 2014/0261046 A1 9/2014 Marx
 2014/0326157 A1 11/2014 Conroy
 2014/0345488 A1 11/2014 Schluckebier et al.
 2014/0373744 A1 12/2014 Padgett et al.
 2015/0007716 A1 1/2015 MacVicar et al.
 2015/0033970 A1 2/2015 Maljkovic et al.
 2015/0033990 A1 2/2015 Yeager
 2015/0036058 A1 2/2015 Ng et al.
 2015/0075400 A1 3/2015 Lemke et al.
 2015/0219573 A1 8/2015 Lukay et al.
 2015/0226220 A1 8/2015 Bevington

2015/0241183 A1 8/2015 Padgett et al.
 2015/0241184 A1 8/2015 Burrow
 2015/0260490 A1 9/2015 Burrow
 2015/0260491 A1 9/2015 Burrow
 2015/0260495 A1 9/2015 Burrow
 2015/0330756 A1 11/2015 Ward
 2015/0360587 A1 12/2015 Hoffmann et al.
 2016/0003587 A1 1/2016 Burrow
 2016/0003588 A1 1/2016 Burrow
 2016/0003589 A1 1/2016 Burrow
 2016/0003590 A1 1/2016 Burrow
 2016/0003593 A1 1/2016 Burrow
 2016/0003594 A1 1/2016 Burrow
 2016/0003595 A1 1/2016 Burrow
 2016/0003596 A1 1/2016 Burrow
 2016/0003597 A1 1/2016 Burrow
 2016/0003601 A1 1/2016 Burrow
 2016/0033241 A1 2/2016 Burrow
 2016/0033246 A1 2/2016 Burrow
 2016/0102030 A1 4/2016 Coffey et al.
 2016/0131464 A1 5/2016 Rubin
 2016/0153757 A1 6/2016 Mahnke
 2016/0161232 A1 6/2016 Rubin
 2016/0238355 A1 8/2016 Dionne et al.
 2016/0245626 A1 8/2016 Drieling et al.
 2016/0265886 A1 9/2016 Aldrich et al.
 2016/0273896 A1 9/2016 Emary
 2016/0349022 A1 12/2016 Burrow
 2016/0349023 A1 12/2016 Burrow
 2016/0349028 A1 12/2016 Burrow
 2016/0356581 A1 12/2016 Burrow
 2016/0356588 A1 12/2016 Burrow
 2016/0377399 A1 12/2016 Burrow
 2017/0080498 A1 3/2017 Burrow
 2017/0082409 A1 3/2017 Burrow
 2017/0082411 A1 3/2017 Burrow
 2017/0089672 A1 3/2017 Burrow
 2017/0089673 A1 3/2017 Burrow
 2017/0089674 A1 3/2017 Burrow
 2017/0089675 A1 3/2017 Burrow
 2017/0089679 A1 3/2017 Burrow

FOREIGN PATENT DOCUMENTS

EP 2625486 A1 8/2013
 GB 783023 9/1957
 WO 2000034732 A1 6/2000
 WO 2007014024 A2 2/2007
 WO 2012047615 A1 4/2012
 WO 2012097317 A2 7/2012
 WO 2012097320 A1 7/2012
 WO 2013070250 A1 5/2013
 WO 2013096848 A1 6/2013
 WO 2014062256 A2 4/2014
 WO 2016003817 A1 1/2016

OTHER PUBLICATIONS

Korean Intellectual Property Office (ISA), International Search Report and Written Opinion for PCT/US2015/038061 dated Sep. 21, 2015, 28 pp.
 Korean Intellectual Property Office (ISA), International Search Report and Written Opinion for PCT/US2011/062781 dated Nov. 30, 2012, 16 pp.

* cited by examiner

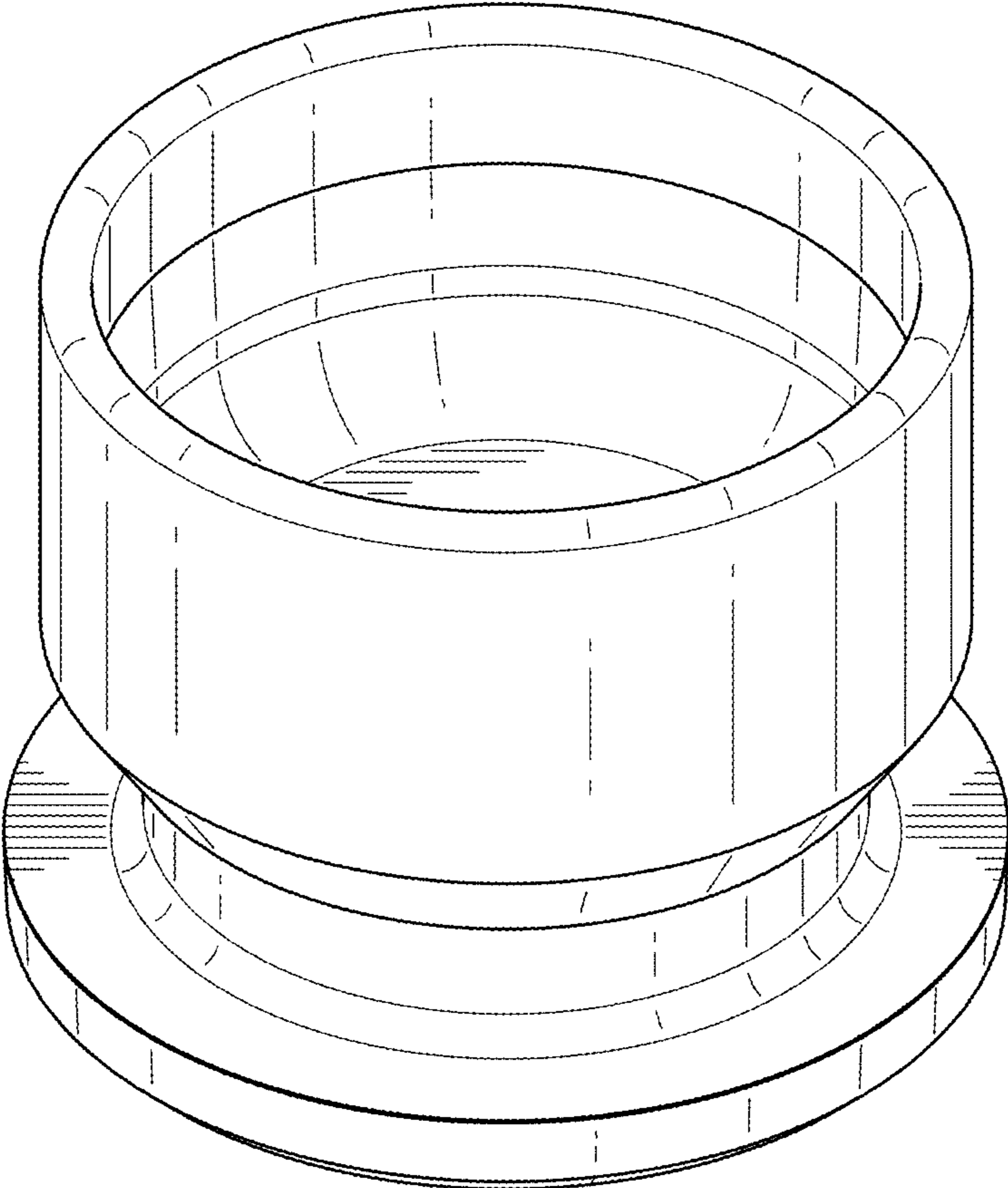

FIG. 1

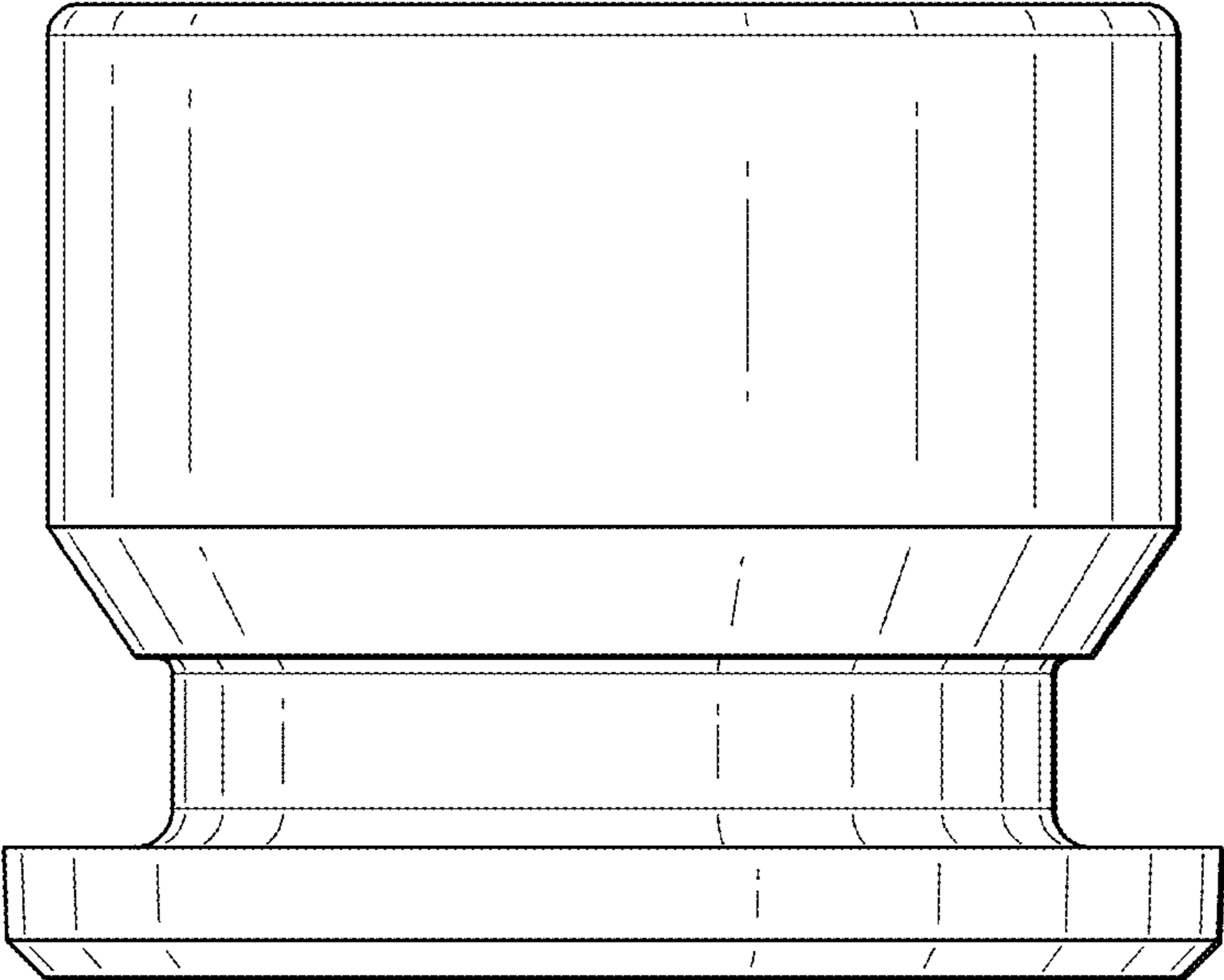

FIG. 2

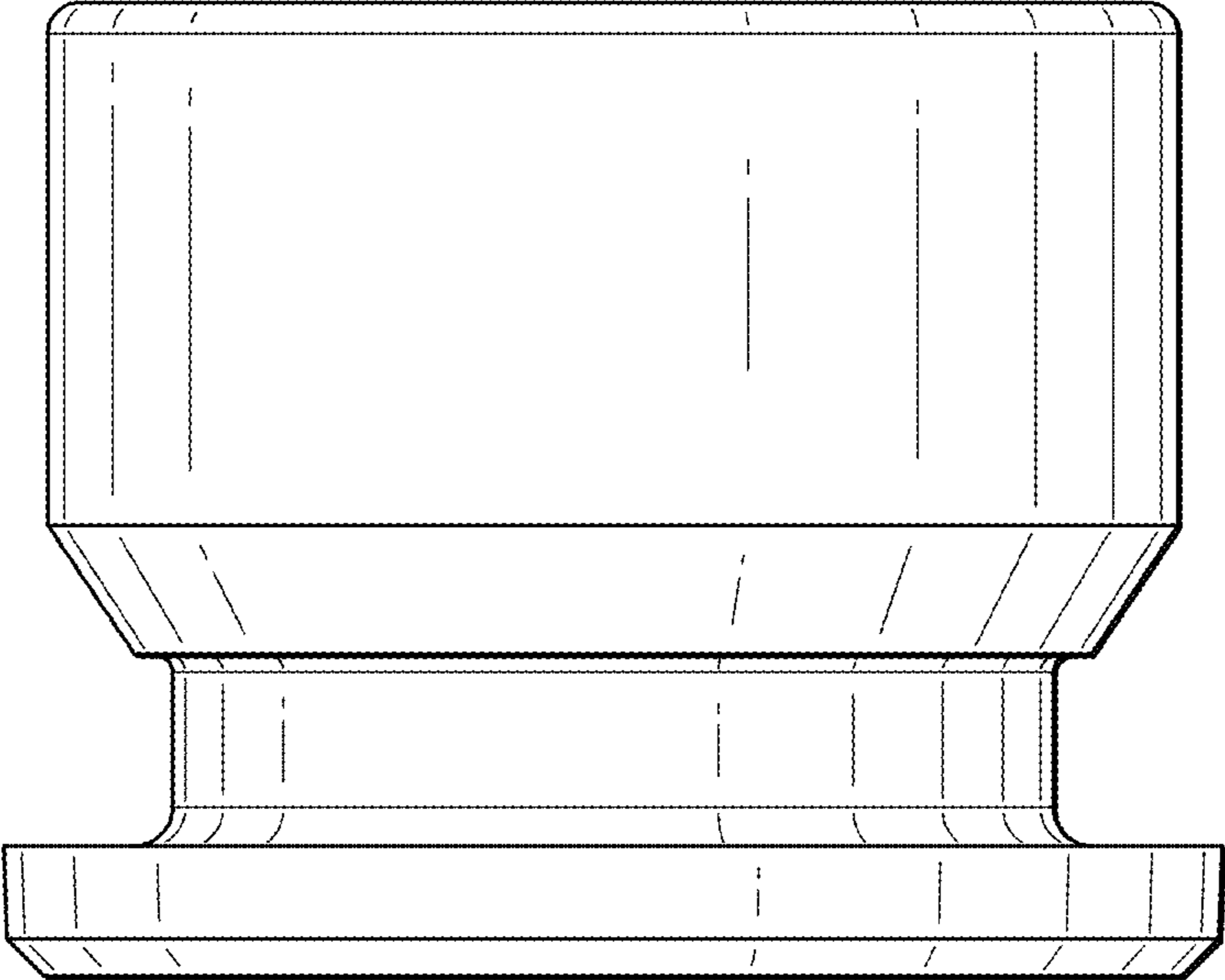

FIG. 3

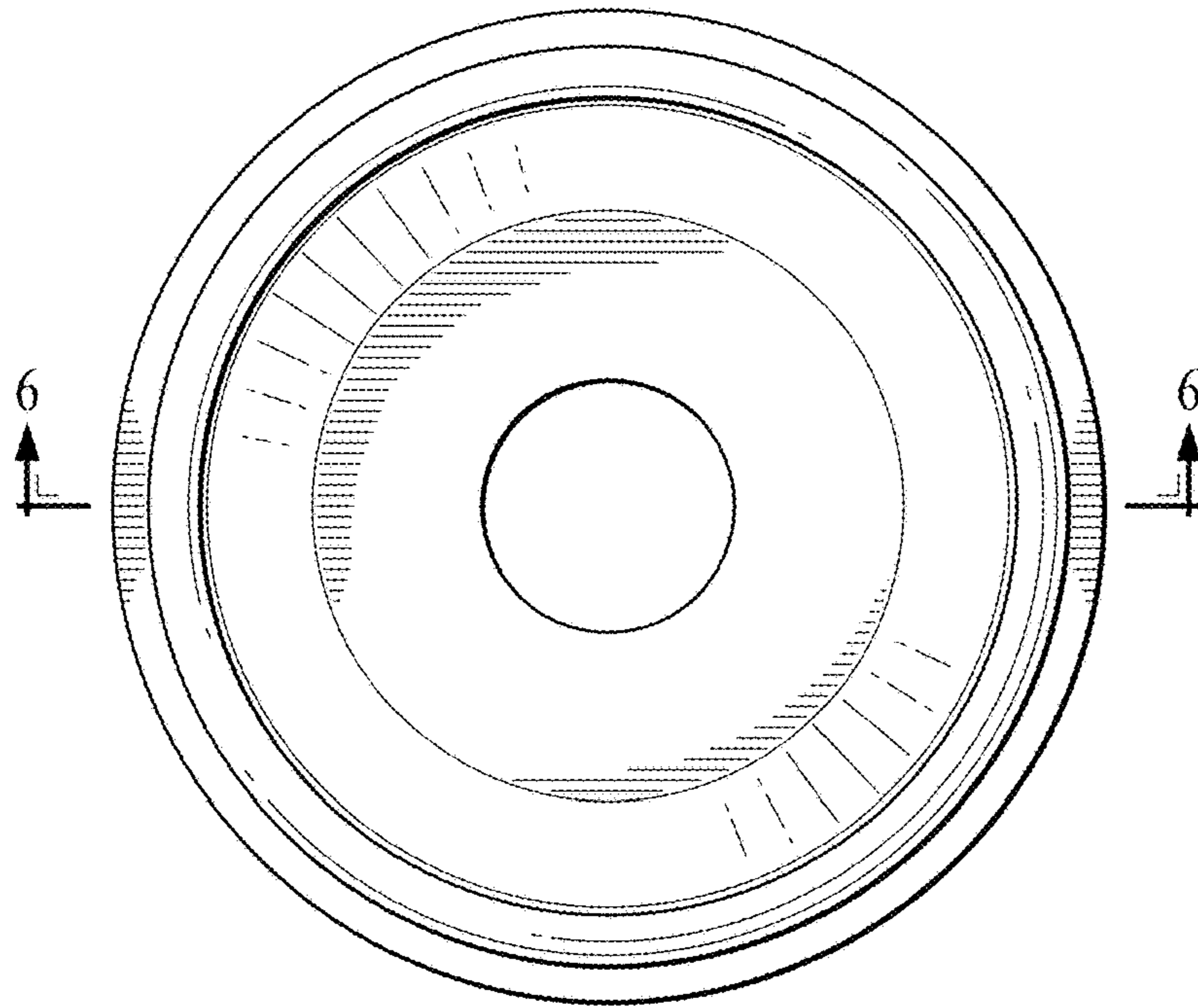

FIG. 4

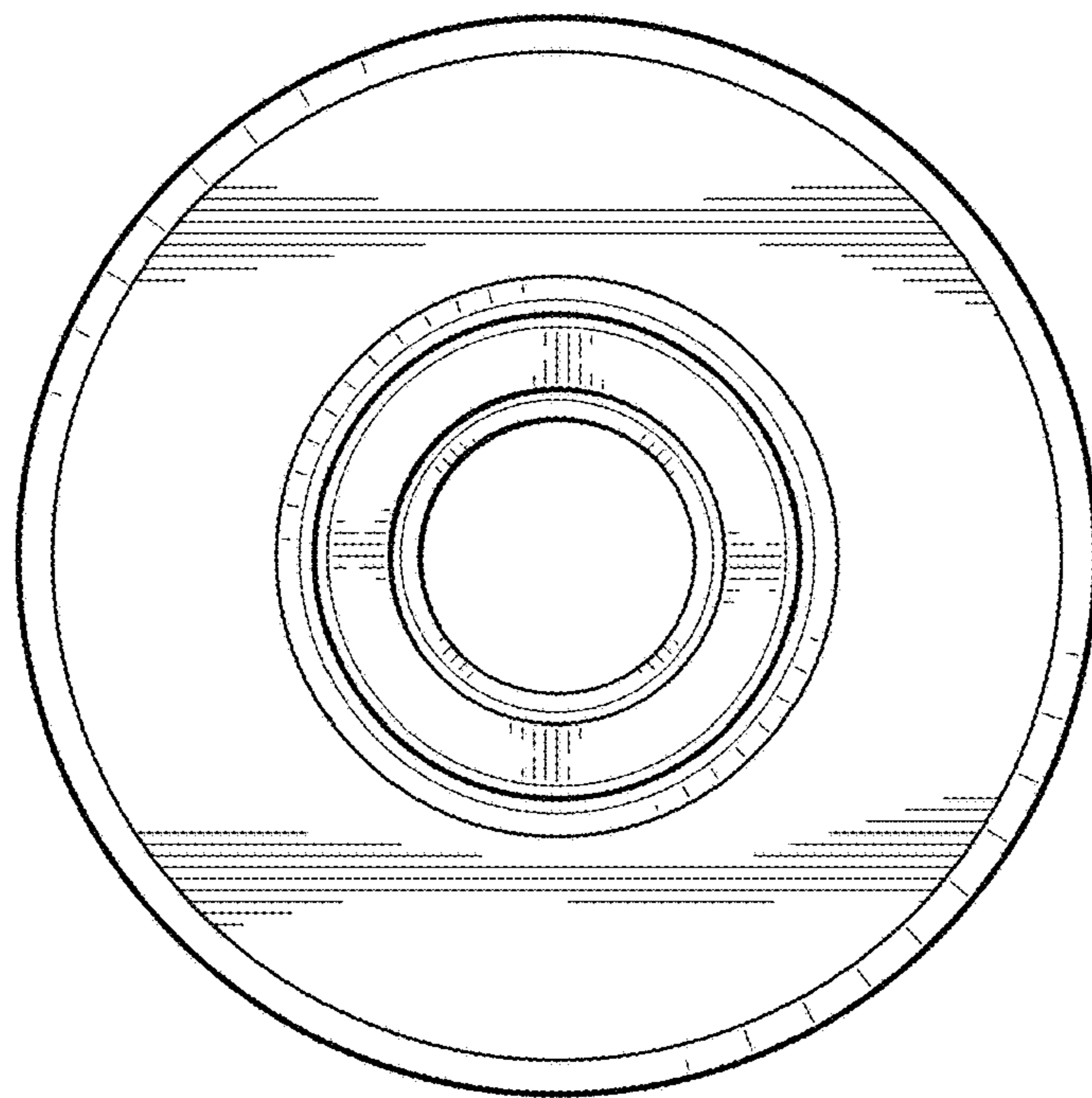

FIG. 5

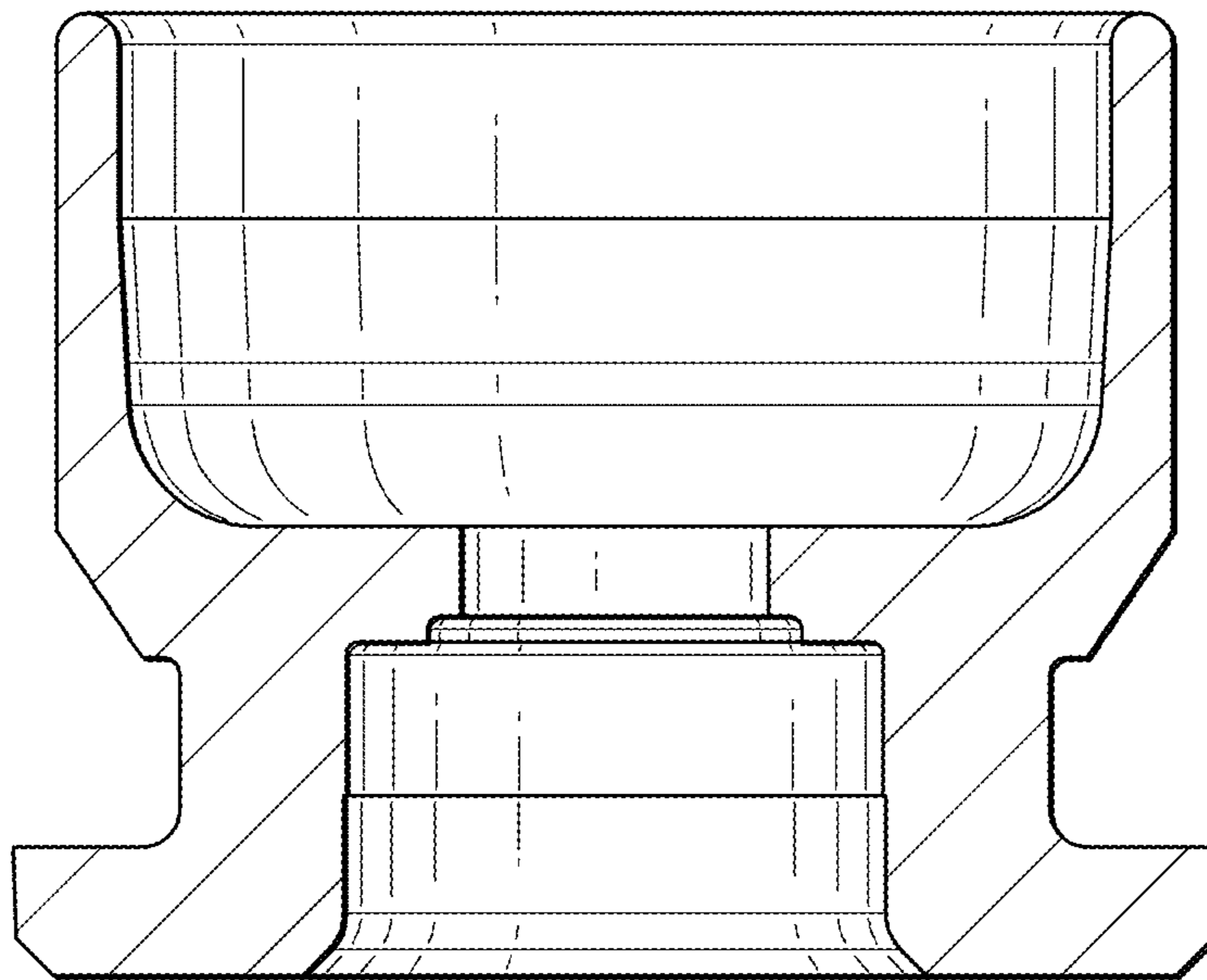

FIG. 6

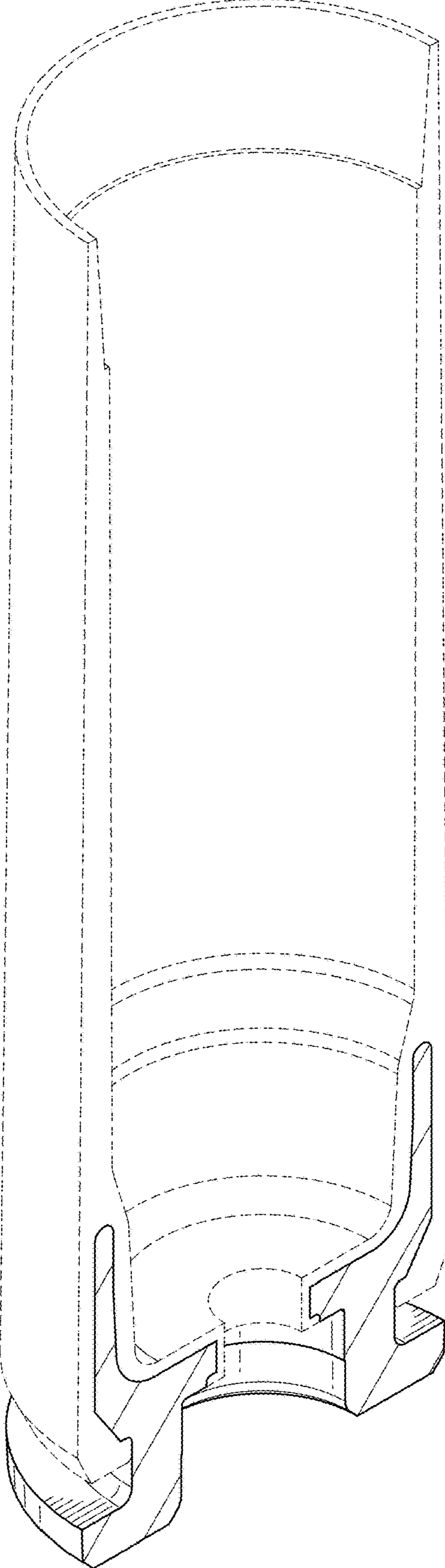

FIG. 7