



US00D828460S

(12) **United States Design Patent** (10) **Patent No.:** **US D828,460 S**  
**Wood** (45) **Date of Patent:** **\*\* Sep. 11, 2018**

(54) **SHOCK TOWER FOR A MODEL VEHICLE**

(71) Applicant: **TRAXXAS LP**, McKinney, TX (US)

(72) Inventor: **Jonathan Scott Wood**, Lewisville, TX (US)

(73) Assignee: **Traxxas, LP**, McKinney, TX (US)

(\*\*) Term: **15 Years**

(21) Appl. No.: **29/592,277**

(22) Filed: **Jan. 27, 2017**

(51) **LOC (11) Cl.** ..... **21-01**

(52) **U.S. Cl.**  
USPC ..... **D21/561**

(58) **Field of Classification Search**  
USPC ..... D21/495, 502, 561, 562; 446/103;  
280/124.155, 124.139; D12/159  
CPC ..... A63H 33/042; A63H 3/16; A63H 30/00;  
A63H 7/04; A63H 31/00; A63H 3/50;  
A63H 17/26; A63H 17/36; A63H 17/262;  
A63H 17/264  
See application file for complete search history.

(56) **References Cited**

**U.S. PATENT DOCUMENTS**

1,135,577	A	4/1915	Hague
1,647,438	A	11/1927	De Ram
1,695,379	A	12/1928	Keck
1,998,477	A	4/1935	Wikander
2,123,681	A	7/1938	Willgoos
2,126,085	A	8/1938	Balz
2,131,661	A	9/1938	Heyermans et al.
2,186,065	A	1/1940	Fischer
2,219,361	A	10/1940	Haberstump

(Continued)

**FOREIGN PATENT DOCUMENTS**

DE	2137757	B2	2/1973
TW	D135320	S	6/2010
TW	D139245	S	3/2011

**OTHER PUBLICATIONS**

Front\_Rear\_Shock\_Tower\_set [online] found on Mar. 5, 2018 from URL <https://www.hobbytown.com/trx4-front-rear-shock-tower-set-by-traxxas-tra8216/p668322>.\*

(Continued)

*Primary Examiner* — Robin Valery Webster

*Assistant Examiner* — Keith J Wilson

(74) *Attorney, Agent, or Firm* — Daryl R Wright; Greg Carr

(57) **CLAIM**

I claim the ornamental design for a shock tower for a model vehicle, as shown and described.

**DESCRIPTION**

FIG. 1 is a top, right, front perspective view of a shock tower for a model vehicle;  
FIG. 2 is a top, left, rear perspective view thereof;  
FIG. 3 is a right elevation view thereof;  
FIG. 4 is a left elevation view thereof;  
FIG. 5 is a rear elevation view thereof;  
FIG. 6 is a front plan view thereof;  
FIG. 7 is a top plan view thereof;  
FIG. 8 is a bottom plan view thereof; and,  
FIG. 9 is a top, front, left perspective environmental view of four shock towers for a model vehicle mounted on a model vehicle platform.

In the drawings, the broken lines depict environmental subject matter only and form no part of the claimed design. Whereas the broken line showing of the model vehicle platform is provided for the purpose of illustrating environmental subject matter only and forms no part of the claimed design. In addition, in FIG. 9, four shock towers for a model vehicle are shown mounted on the model vehicle platform but only a single shock tower for a model vehicle is claimed.

**1 Claim, 5 Drawing Sheets**

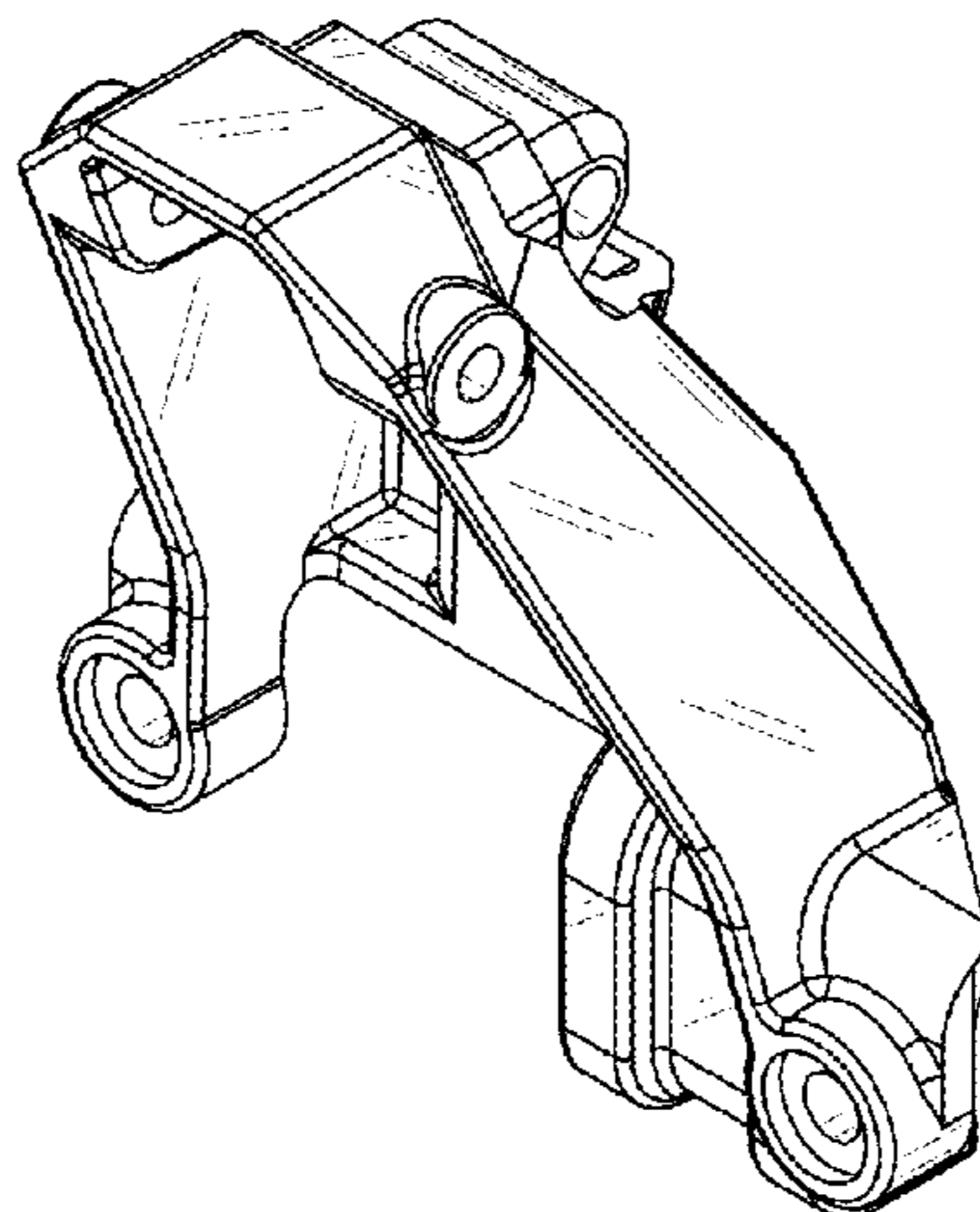

(56)

References Cited

U.S. PATENT DOCUMENTS

2,580,559 A 1/1952 Kolbe  
 2,643,110 A 6/1953 Gregoire  
 2,776,147 A 1/1957 Bamford  
 2,913,253 A 11/1959 Taber  
 2,931,663 A 4/1960 Ferand  
 2,992,014 A 7/1961 Muller  
 3,177,004 A 4/1965 Schmidt  
 3,448,991 A 6/1969 Leggett  
 3,545,125 A 12/1970 Okuma  
 3,591,198 A 7/1971 Brando  
 3,632,127 A 1/1972 Grosseau  
 3,671,694 A 6/1972 Masuda  
 3,721,455 A 3/1973 Blanton  
 3,727,938 A 4/1973 Goodbary et al.  
 3,738,631 A 6/1973 Haley  
 3,787,073 A 1/1974 Lievore  
 D262,959 S 2/1982 Cowan  
 4,470,611 A 9/1984 Dunphily et al.  
 D277,952 S 3/1985 Nakano et al.  
 4,534,575 A 8/1985 Grove et al.  
 D281,772 S 12/1985 Heideman et al.  
 D295,769 S \* 5/1988 Olsen ..... D21/495  
 4,786,075 A 11/1988 Takahashi  
 D304,221 S 10/1989 Poulsen  
 4,881,752 A 11/1989 Tanaka  
 4,955,634 A 9/1990 Smith  
 5,071,384 A 12/1991 Poulsen  
 5,080,389 A 1/1992 Kawano et al.  
 5,108,126 A 4/1992 Banse  
 D337,555 S 7/1993 McNab et al.  
 D341,170 S 11/1993 Olsen  
 5,536,035 A \* 7/1996 Bautz ..... B60G 3/20  
 280/124.139  
 5,682,489 A 10/1997 Harrow et al.  
 5,774,984 A 7/1998 Kotani  
 5,839,742 A 11/1998 Holt  
 5,845,926 A 12/1998 Davis et al.  
 D409,681 S 5/1999 Poulsen  
 D411,263 S 6/1999 Korsholm  
 6,047,988 A \* 4/2000 Aloe ..... B60G 7/02  
 280/124.134  
 6,142,268 A 11/2000 Kuo-An  
 D435,236 S 12/2000 Hanlon et al.  
 6,170,838 B1 1/2001 Laurent et al.  
 D446,263 S 8/2001 Heys  
 D468,252 S \* 1/2003 Morris ..... D12/223  
 6,550,796 B2 4/2003 Behr  
 6,641,457 B1 11/2003 Lai  
 6,655,118 B1 12/2003 Thompson et al.  
 6,668,779 B2 12/2003 Hendriksma et al.  
 6,702,307 B2 3/2004 Becker et al.  
 6,719,313 B2 4/2004 Zadok  
 6,761,372 B2 7/2004 Bryant  
 D493,848 S 8/2004 Dunst  
 6,881,122 B2 4/2005 Bloch et al.  
 6,945,843 B1 9/2005 Motosko  
 7,185,902 B1 3/2007 Lloyd  
 D546,751 S 7/2007 Laatz  
 D567,886 S 4/2008 Lampert et al.  
 7,367,573 B2 5/2008 Kudo et al.  
 7,887,074 B2 2/2011 Byers et al.  
 D647,826 S \* 11/2011 Goettker ..... D12/162  
 9,855,975 B2 \* 1/2018 Amemiya ..... B62D 21/00  
 2002/0041076 A1 4/2002 Becker et al.  
 2002/0077025 A1 6/2002 Wu  
 2002/0125676 A1 9/2002 Bryant  
 2003/0122336 A1 7/2003 Zadok  
 2003/0209217 A1 11/2003 Hendriksma et al.  
 2004/0045518 A1 3/2004 Abe

2004/0261739 A1 12/2004 Shimizuya  
 2005/0040619 A1 2/2005 Melcher  
 2006/0006622 A1 1/2006 Gesmer et al.  
 2012/0169023 A1 7/2012 Rawlinson et al.

OTHER PUBLICATIONS

Associated Electrics, "Monster GT" model truck; Associated Electrics, Inc., Costa Mesa, California, 1 photograph.  
 Associated Electrics, "RC10GT" model vehicle; Associated Electrics, Inc., Costa Mesa, California, 1 photograph.  
 Bradley, John; "The Racing Motorcycle"; 1996, pp. 246-273, 322-325; Broadland Leisure Publications, England.  
 Ellsworth, Tony; "Suspension Design Enhancements—The Ellsworth Dare"; Dreamride Mountain Bike Tours and Film Services, Moab, Utah, 2001.  
 Horizon Hobby, "Losi XXX buggy"; Horizon Hobby, Inc., Champaign, Illinois; 1 sketch of suspension geometry.  
 HPI Racing, "Savage 21" model truck; Hobby Products International, Foothill Ranch, California; 1 sketch of suspension geometry.  
 HYPERPRO\_USA; "What is Progressive Suspension?" HyperPRO\_USA.com.  
 Kyosho Inferno MP7.5 model car; Kyosho America, Lake Forest, California; 2 sketches of suspension geometry.  
 Milliken, William F. and Milliken, Douglas L.; "Race Car Vehicle Dynamics" 1995, pp. 580-583, 595-597, 628-631; SAE Publications Group, Pennsylvania USA.  
 Phillipotts, Peter; "Rising Rate Suspension"; Off Road Design, 2001.  
 Race Tech, "Profile—Chalmers Formula SAE Car" Race Tech magazine, Oct./Nov. 2003, p. 74; Racecar Graphic Ltd, London, England.  
 Racecar Engineering, Jun. 2003—vol. 13 No. 06, pp. 15, 106; Country & Leisure Media Ltd./IPC Media Ltd., Croydon, England.  
 Salven, Michael; "Progressive Suspension" Nov. 10, 2000; myTSN—Publication, Netherlands.  
 Serpent, Veteq; Serpent Model Racing Cars, Noord-Holland, Netherlands; 3 pictures.  
 Serpent, Veteq; Serpent Model Racing Cars, Noord-Holland, Netherlands; 1 sketch of suspension geometry.  
 Staniforth, Allan; "Competition Car Suspension" 1988, pp. 76-81, 84-85; Haynes Publications, Newbury Park, California.  
 Tamiya, "Terra Crusher" model truck; Tamiya America, Inc., Aliso Viejo, California; 1 sketch of suspension geometry.  
 Traxxas, "Nitro Rustler" model vehicle; Traxxas LP, Plano, Texas; 1 photograph.  
 Traxxas; "T-MAXX Assemblies, Front Assembly" exploded view; Traxxas LP, Plano, Texas.  
 Traxxas, "T-MAXX" model vehicle; Traxxas LP, Plano, Texas; 1 photograph.  
 Full size vehicle with suspension linkage #1.  
 Full size vehicle with suspension linkage #2.  
 Axial SCX10 II Shock Hoops AX131380; <http://www.axialracing.com/products/ax31380>; Aug. 2016.  
 HPI Venture FJ Cruiser; <http://www.hpiracing.com/en/article/view/2016012702>; Jan. 27, 2016.  
 Taiwan IPO Search Report, Taiwan Design App No. 105301437; Aug. 4, 2016.  
 Taiwan IPO Search Report, Taiwan Design App No. 106300762; May 16, 2017.  
 L. Granieri; U.S. Pat. No. 903,080; Road Vehicle Wheel Axle; Nov. 3, 1908.  
 H. Ewing; U.S. Pat. No. 951,000; Spring Controlled Vehicle Wheel Link; Mar. 1, 1910.  
 Amazon (online) found on Oct. 10, 2017, from URL [https://www.amazon.com/Traxxas-7739-X-Maxx-Front-Shock/dp/B01A6YD2F4/ref=sr\\_1\\_22?s=toys-and-games&ie=UTF8&qid=1507663677&sr=1-22&keywords=shock+tower](https://www.amazon.com/Traxxas-7739-X-Maxx-Front-Shock/dp/B01A6YD2F4/ref=sr_1_22?s=toys-and-games&ie=UTF8&qid=1507663677&sr=1-22&keywords=shock+tower) (Year: 2017).

\* cited by examiner

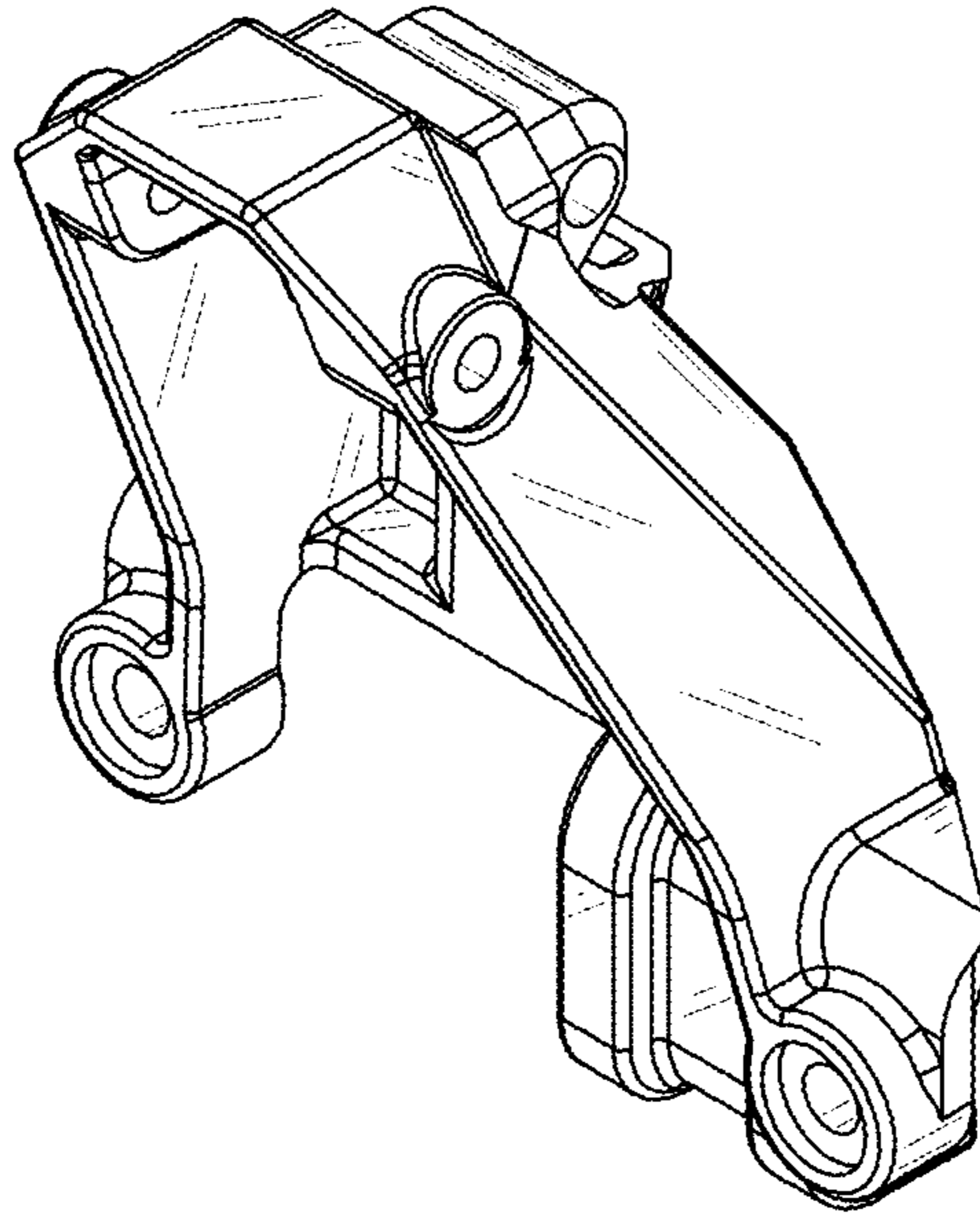

**FIG. 1**

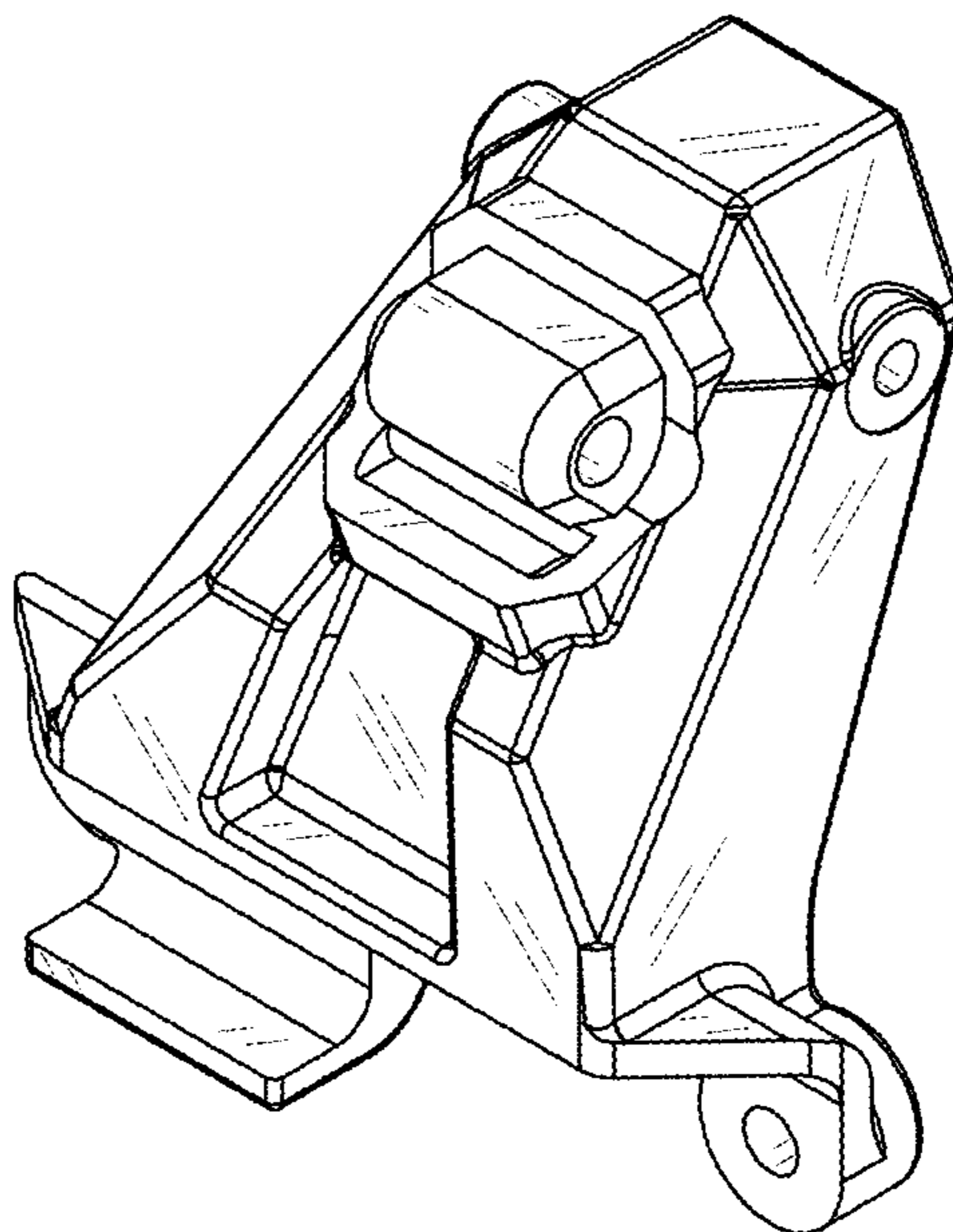

**FIG. 2**

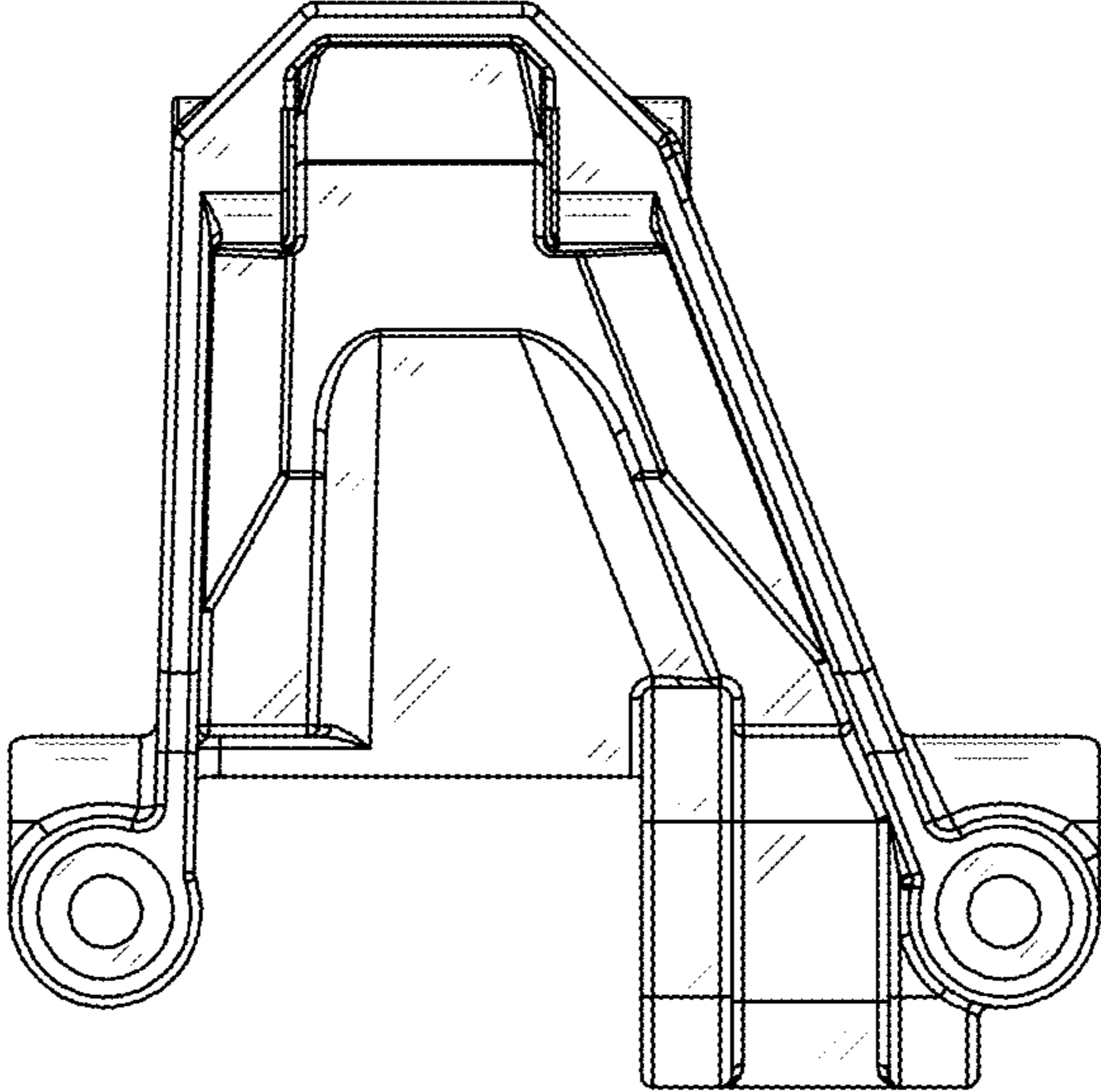

**FIG. 3**

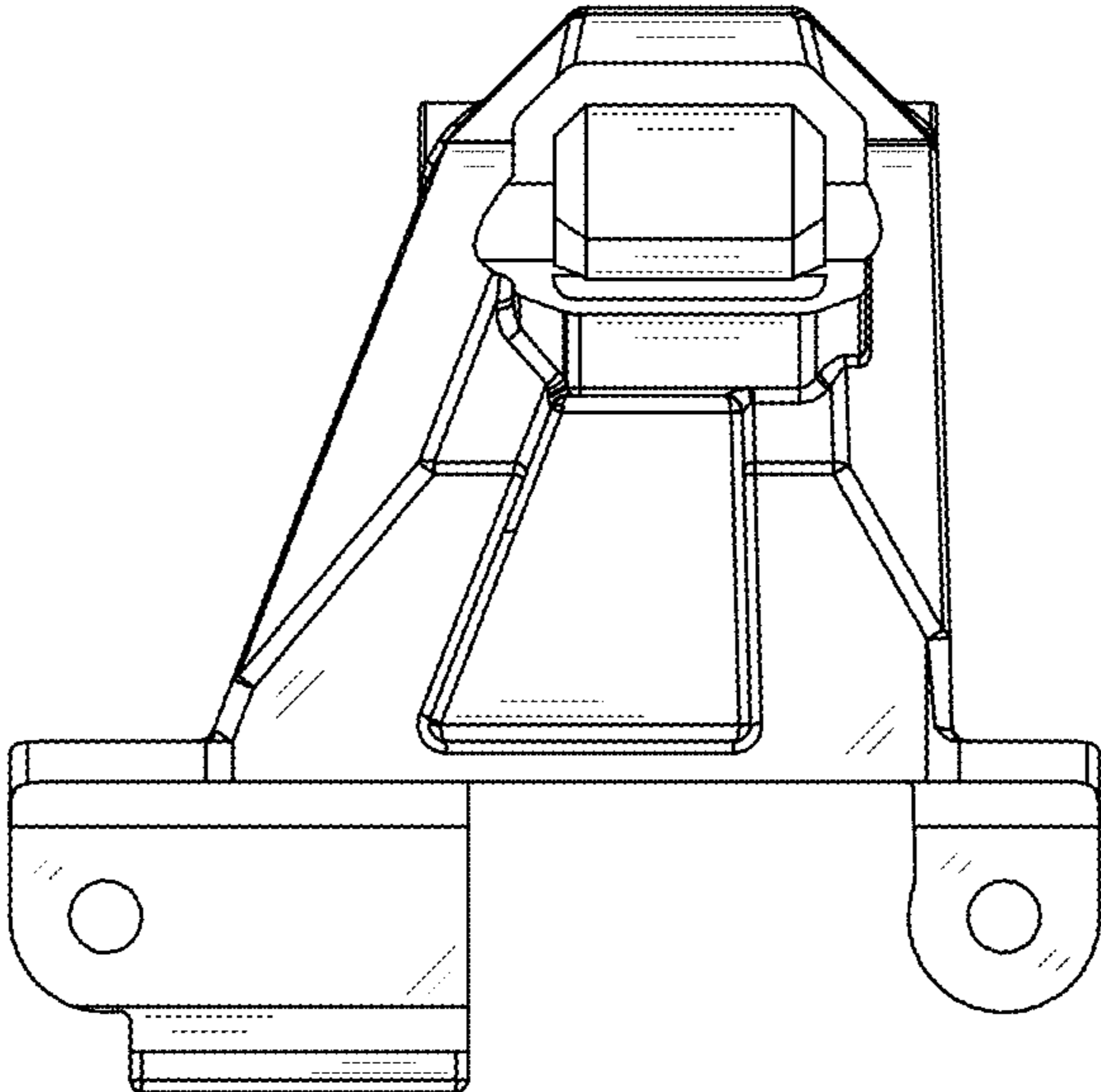

**FIG. 4**

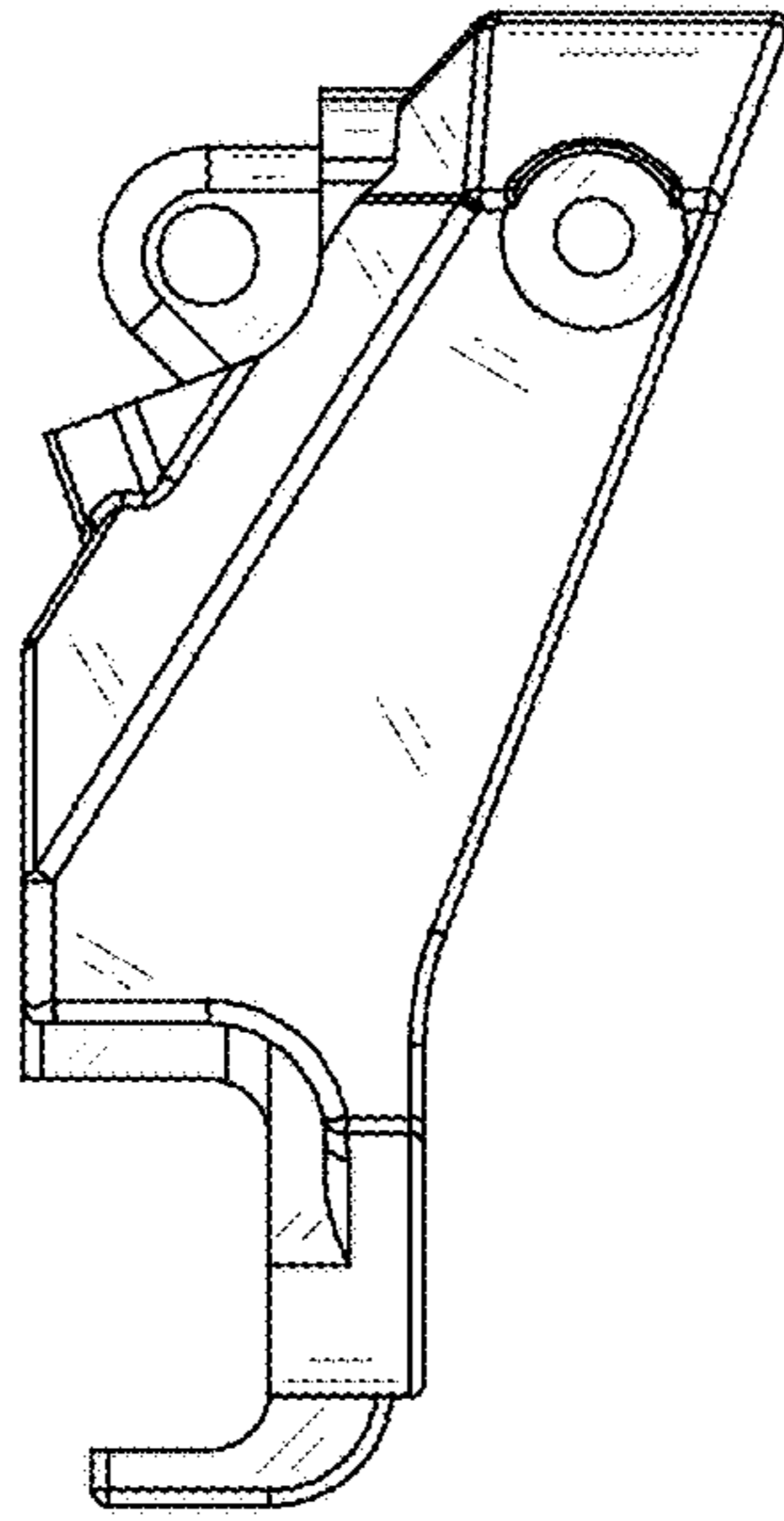

**FIG. 5**

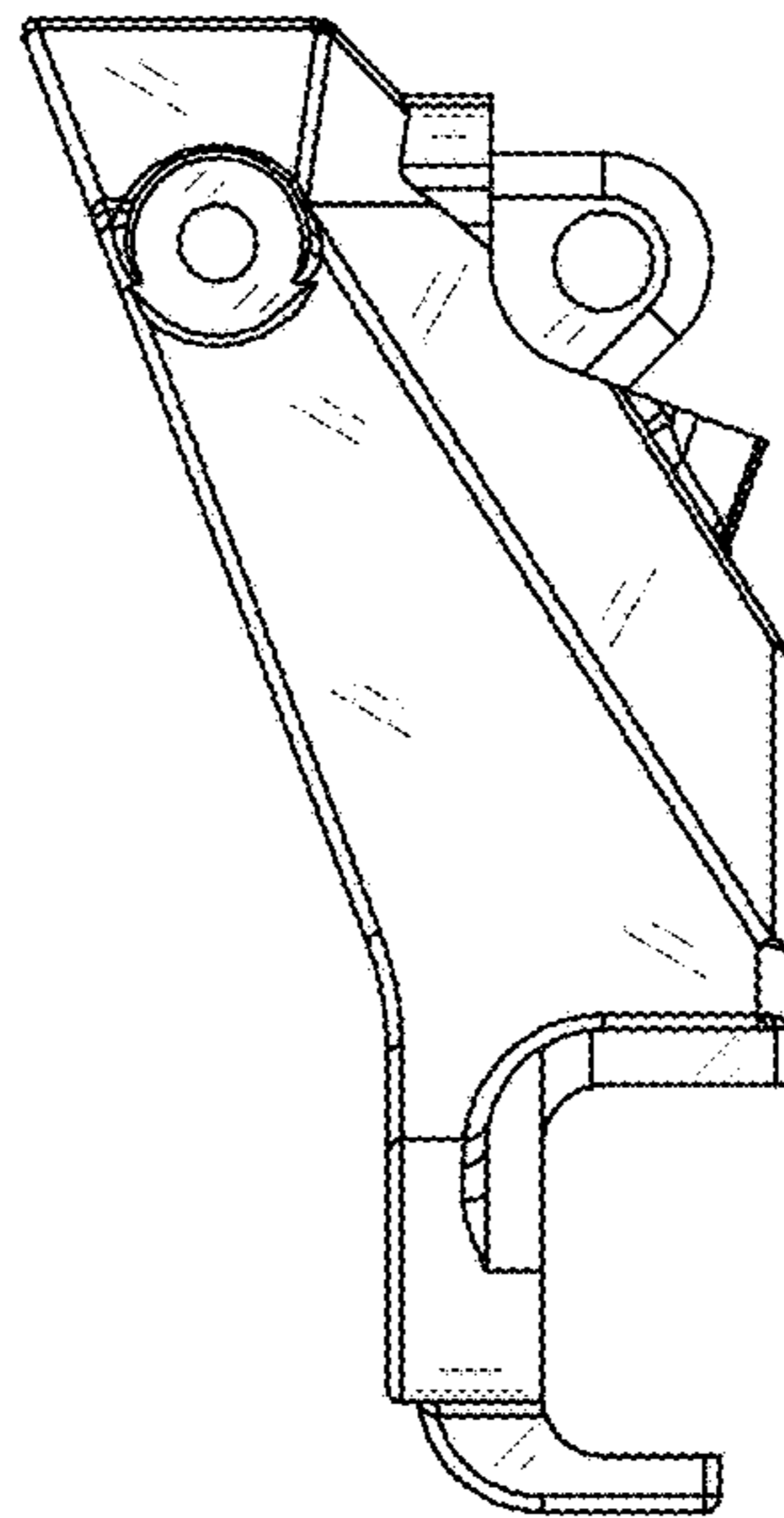

**FIG. 6**

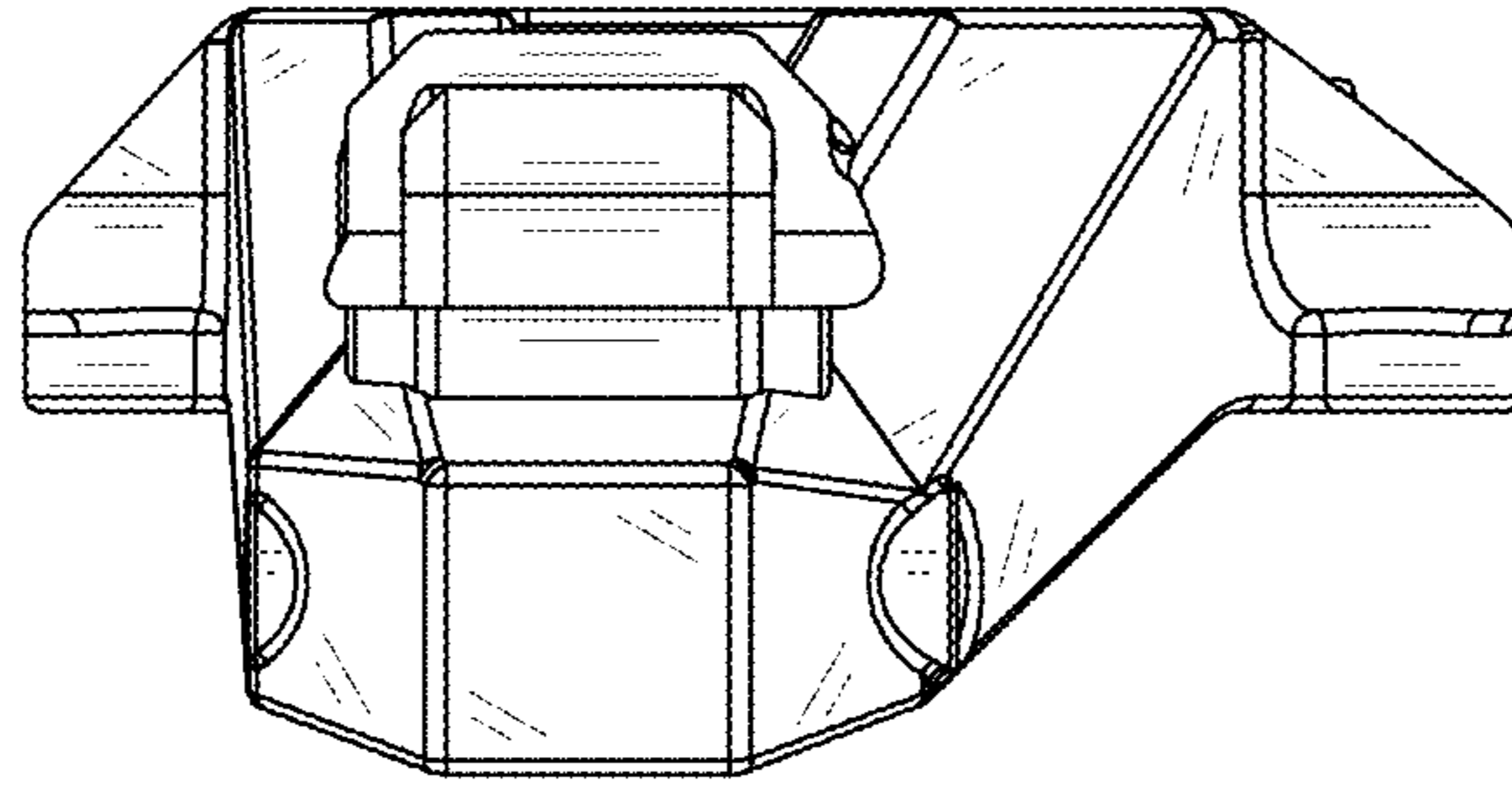

**FIG. 7**

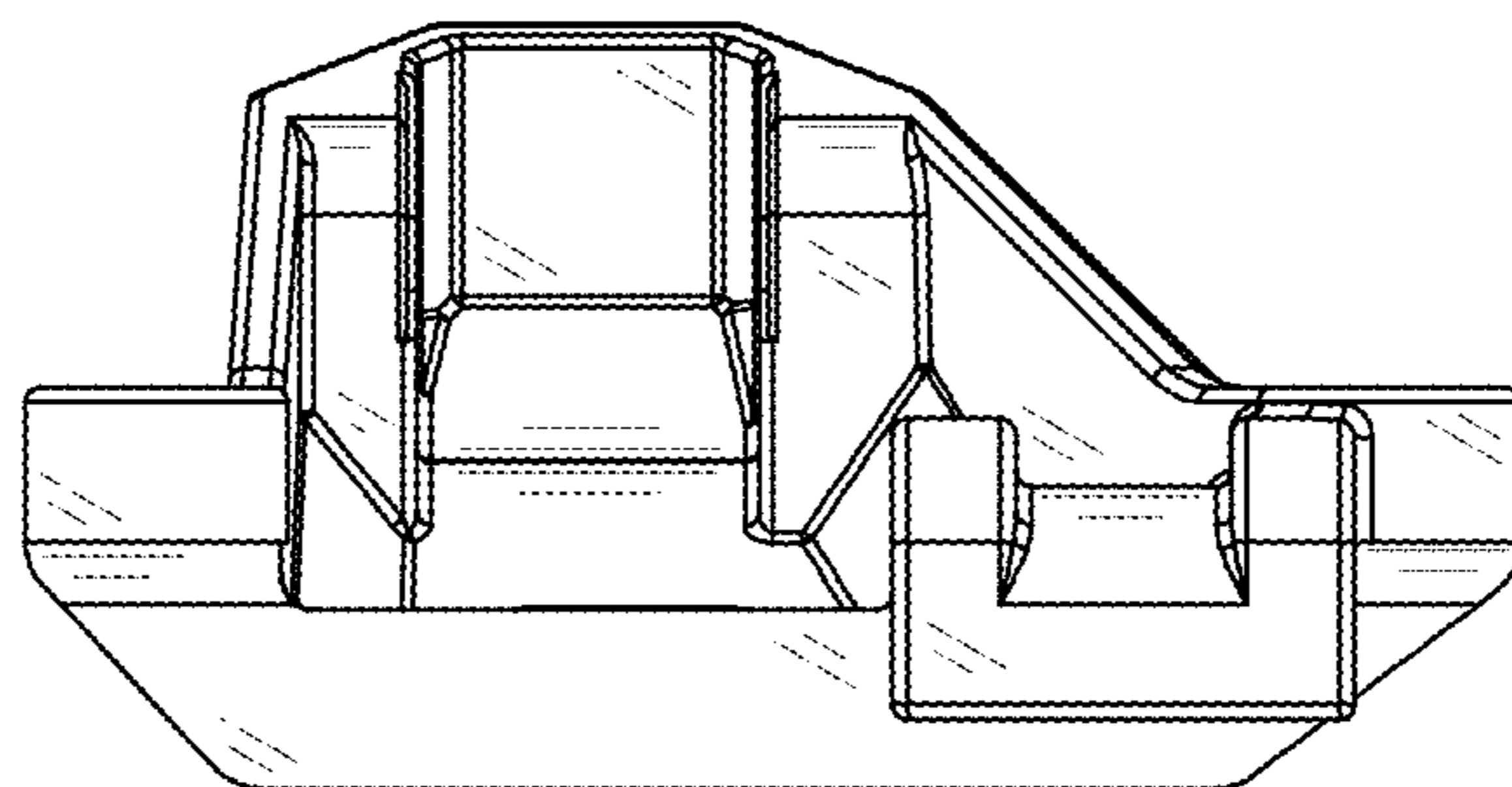

**FIG. 8**

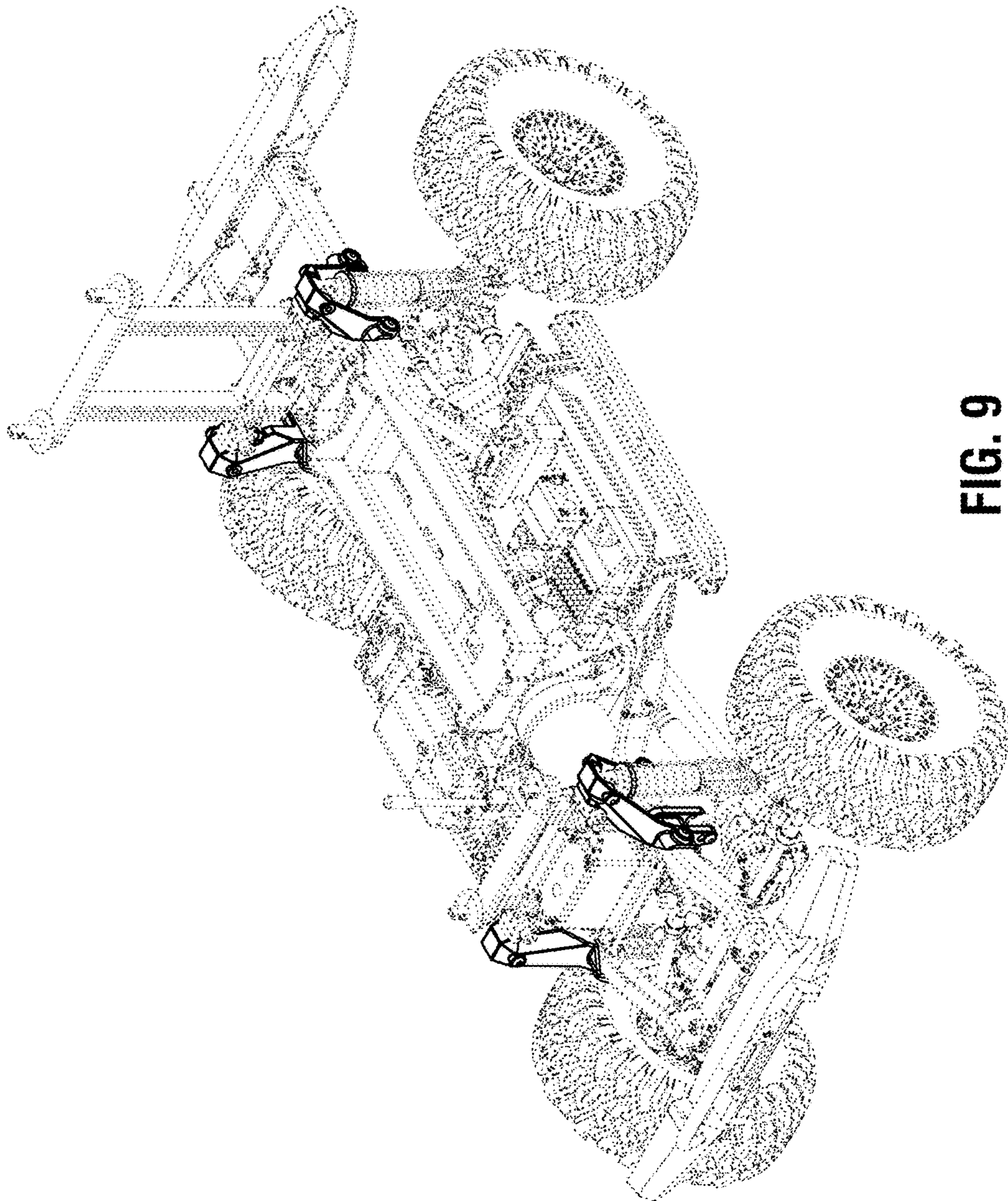

FIG. 9