



US00D828440S

(12) **United States Design Patent** (10) **Patent No.:** **US D828,440 S**  
**Trifilio** (45) **Date of Patent:** **\*\* Sep. 11, 2018**

(54) **GUITAR EFFECTS PEDALBOARD**

(71) Applicant: **Chemistry Design Werks LLC**, St. Paul, MN (US)

(72) Inventor: **Christian Richard Trifilio**, St. Paul, MN (US)

(73) Assignee: **Chemistry Design Werks LLC**, Saint Paul, MN (US)

(\*\*) Term: **15 Years**

(21) Appl. No.: **29/593,110**

(22) Filed: **Feb. 6, 2017**

(51) **LOC (11) Cl.** ..... **17-03**

(52) **U.S. Cl.**  
USPC ..... **D17/20**

(58) **Field of Classification Search**

USPC ..... D17/1, 2, 4, 5, 7-9, 13, 14, 20, 21, 24, D17/99; D19/99-101, 150, 192; D6/329, D6/512-514, 641, 650, 707, 702; D7/550.1, 554.2, 554.3, 698; D10/103; D14/299, 328, 432, 447; D23/393; D21/405, 406, 408, 409, 586; D32/56; D8/354; D25/119

CPC ..... G10H 2220/071; G10H 2220/076; G10H 2220/165; G10H 2220/221; G10H 2220/30; G10H 2220/485; G10H 3/186; G10H 2210/231; G10D 13/023; G10D 13/027; G10D 13/006; G10D 3/006

See application file for complete search history.

(56) **References Cited**

**U.S. PATENT DOCUMENTS**

3,374,558 A \* 3/1968 Smith, Jr. .... G09B 19/02 273/282.1  
D290,679 S \* 7/1987 Thorpe ..... D23/261  
D311,458 S 10/1990 La Croix

D354,636 S \* 1/1995 Cable ..... D19/113  
D390,718 S \* 2/1998 Howland ..... 6/406.6  
D395,969 S 7/1998 Barlow-Lawson  
D442,027 S \* 5/2001 Peters ..... D7/397

(Continued)

**FOREIGN PATENT DOCUMENTS**

KR 3020100032082 S 7/2010

**OTHER PUBLICATIONS**

Walmart, Allsop Large Metal Monitor Stand, customer review on Oct. 23, 2011, [online], [site visited on Jan. 9, 2018]. Available from Internet, <URL: <https://www.walmart.com/ip/Allsop-Large-Metal-Monitor-Stand/16609086>> (Year: 2011).\*

(Continued)

*Primary Examiner* — Sheryl Lane

*Assistant Examiner* — Samantha N Wood

(74) *Attorney, Agent, or Firm* — Grumbles Law PLLC; Brittany Nanzig

(57) **CLAIM**

The ornamental design for a guitar effects pedalboard, as shown and described.

**DESCRIPTION**

FIG. 1 is a top plan view of a guitar effects pedalboard showing my new design.

FIG. 2 is a front elevational view of the guitar effects pedalboard.

FIG. 3 is a back elevational view of the guitar effects pedalboard.

FIG. 4 is a bottom plan view of the guitar effects pedalboard.

FIG. 5 is a right side elevational view of the guitar effects pedalboard; and,

FIG. 6 is a front right side perspective view of the guitar effects pedalboard.

The broken lines in the drawings depict parts of the guitar effects pedalboard that form no part of the claimed design.

**1 Claim, 3 Drawing Sheets**

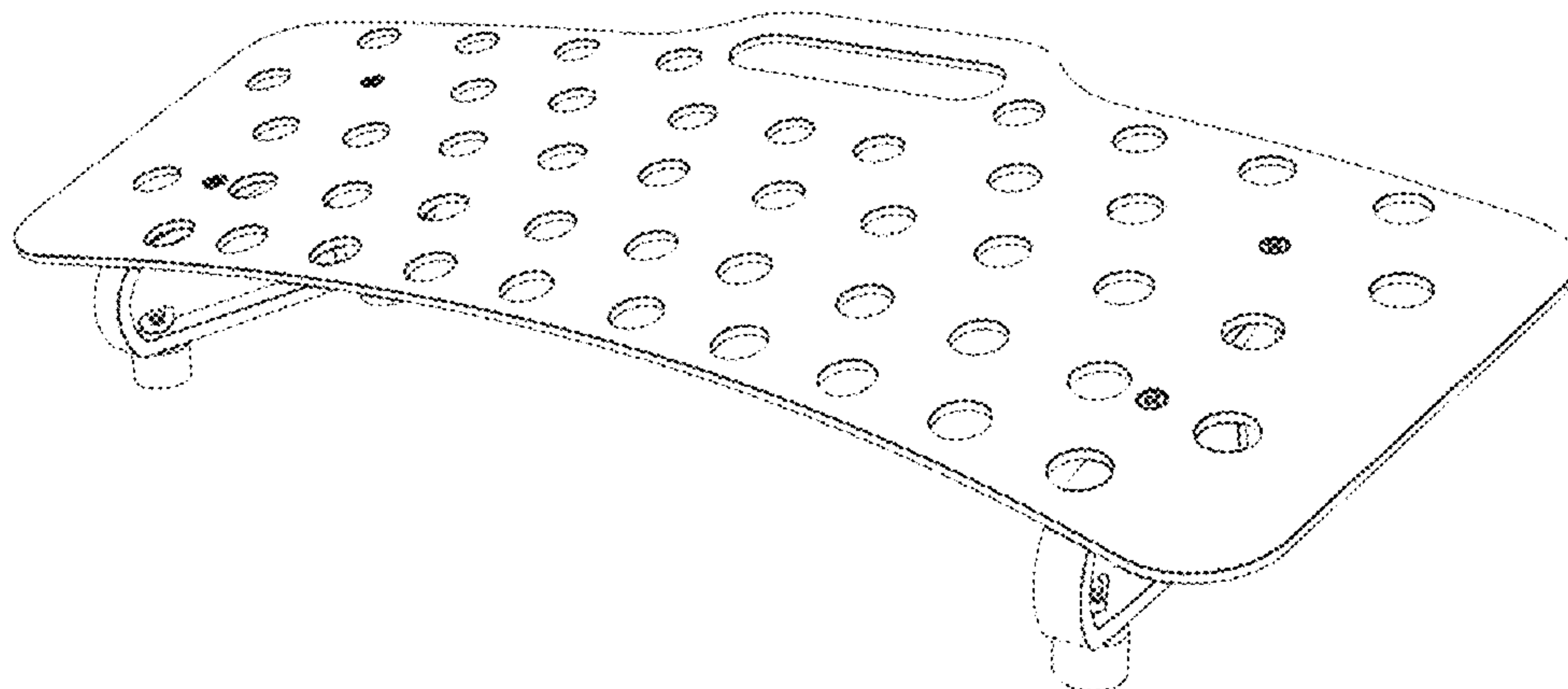

(56)

References Cited

U.S. PATENT DOCUMENTS

6,459,023	B1	10/2002	Chandler	
6,538,185	B1	3/2003	Stratton	
D493,256	S *	7/2004	Kim .....	D24/230
D554,647	S *	11/2007	Chan .....	D14/447
7,293,751	B2	11/2007	Eriksson	
D574,005	S	7/2008	Chung	
D594,564	S	6/2009	Disch et al.	
D637,600	S *	5/2011	Leyva-Menendez .....	D14/447
D689,741	S *	9/2013	Wang .....	D7/554.3
D690,708	S	10/2013	Smith et al.	
D724,343	S *	3/2015	Sinha .....	6/406.3
D745,923	S	12/2015	Trifilio	
D745,924	S	12/2015	Trifilio	
D769,364	S	10/2016	Trifilio	
D795,334	S *	8/2017	Kreifeldt .....	D17/20
2003/0230220	A1	12/2003	Evans et al.	
2004/0250673	A1	12/2004	Salerno	
2006/0120550	A1	6/2006	McCann	
2007/0295190	A1	12/2007	Collins	
2011/0271821	A1	11/2011	McKinney et al.	

OTHER PUBLICATIONS

“My New Pedalboard,” Posted at musiciansroadhouse.com, earliest date available Dec. 1, 2015, [online], acquired on Jul. 1, 2016. Available from Internet, <URL: <http://musiciansroadhouse.com/viewtopic.php?t=4562&start=300>>.

“Chemistry Design Werks Holeyboard Wide Review—Best Guitar Pedalboard?,” posted at bestguitareffects.com, earliest date available Aug. 23, 2013, [online], acquired on Jul. 1, 2016. Available from Internet, <URL: <http://www.bestguitareffects.com/chemistry-design-werks-holeyboard-wide-review-best-guitar-pedalboard>>.

Pedaltrain; Pedal Boards—Pedaltrain; Website; Jul. 27, 2014; <http://www.pedaltrain.com/pedalboards>.

Trailer Trash Pedalboards; Trailer Trash Pedal Boards: Custom Pedalboards; Website; Feb. 7, 2005; <http://trailertrashpedalboards.com>.

Rogue Guitar Shop; Pedalboards—Rogue Guitar Shop; Website; Oct. 10, 2014; <http://www.rogueguitarshop.com/collections/pedalboards>.

Gator Cases, Inc.; Pedal Boards and Stands; Website; Mar. 3, 2012; <http://www.gatorcases.com/c/16108/pedal-boards-and-stands>.

Blackbird; Blackbird Custom Pedalboards; Website; May 19, 2013; <http://blackbirdpedalboards.com>.

Fix Pedal Boards; Welcome to FIX Pedalboards; Website; Apr. 21, 2013; <http://blackbirdpedalboards.com>.

MKS Professional Stage Products, Inc; Pedal Pad Get Serious; Website; Apr. 29, 2013; <http://www.pedalpad.com>.

Phantom Pedalboards; Phantom Pedalboards; Website; Apr. 1, 2015; <http://www.phantompedalboards.com/boards/index>.

SKB Corporation; Guitar Products; Website; Jun. 3, 2014; <https://www.skbcases.com/music/products/prodlist.php?c=85&s=75>.

Renovo AMP Works; Stombox Modular Pedalboards; Website; Jan. 22, 2015; <http://www.stompbox.com>.

Diago; Diago Hardcase Pedalboards; Website; Apr. 23, 2012; <http://www.diago.co.uk/pedalboards/diago-pedalboards.html>.

LYT Pedalboards; LYT Pedalboards; Website; Jan. 1, 2012; <http://www.lytpedalboards.com>.

Llevinac SL; Aclam Guitars; Website; 2015; <https://www.aclamguitars.cat/shop/en/pedalboards/>.

Prosecution History from U.S. Appl. No. 15/231,314, dated Aug. 8, 2016 through Feb. 10, 2017, 112 pp.

Prosecution History from U.S. Appl. No. 29/578,865, dated Sep. 26, 2016 through Dec. 27, 2016, 162 pp.

Prosecution History from U.S. Appl. No. 29/540,570, dated Sep. 25, 2015 through Oct. 18, 2016, 127 pp.

GideonD's, Little Holey Vengeance Pedal Board, posted on Jun. 12, 2012, [online], [site visited on Jan. 10, 2018]. Available from Internet, <URL: <https://gideon.wordpress.com/2012/06/12/little-holey-vengeance-pedal-board-followup-1/>> (Year: 2012).

\* cited by examiner

FIG. 1

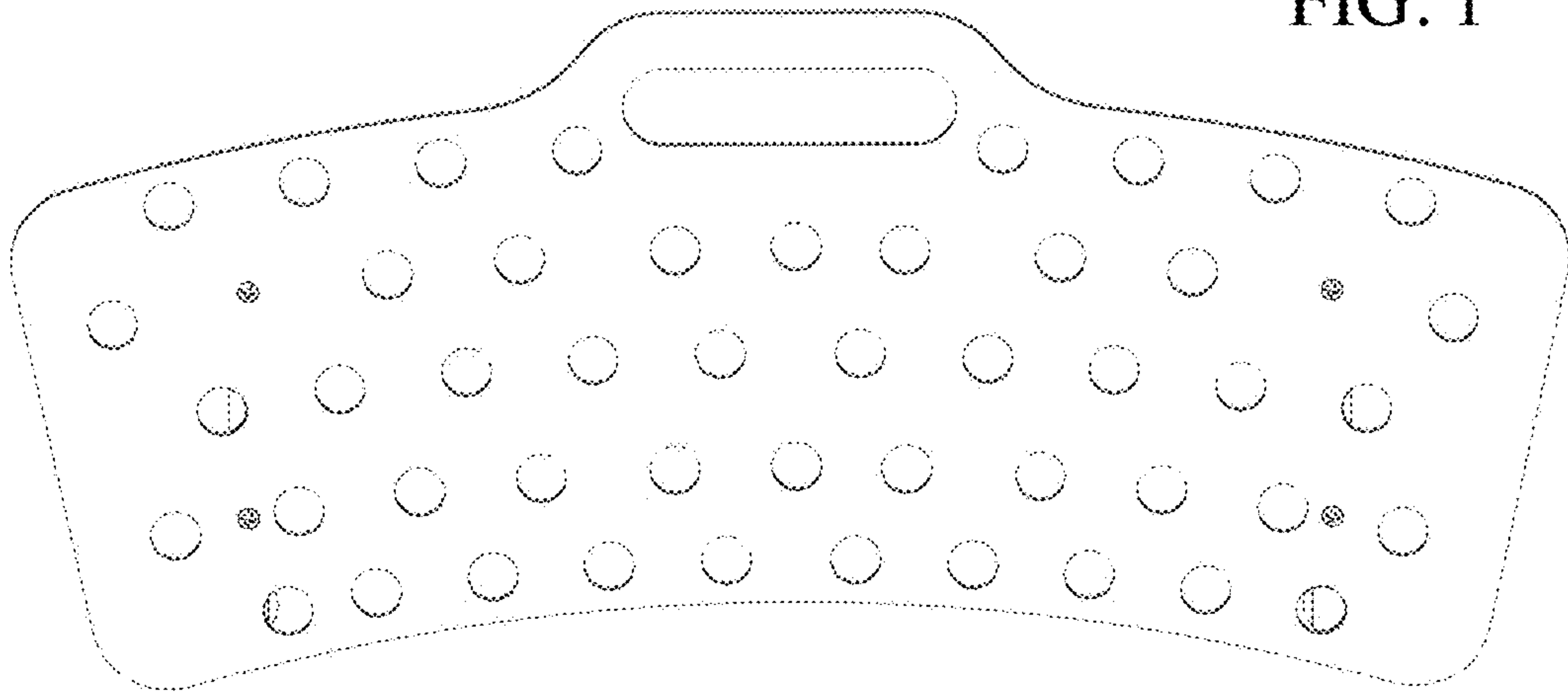

FIG. 2

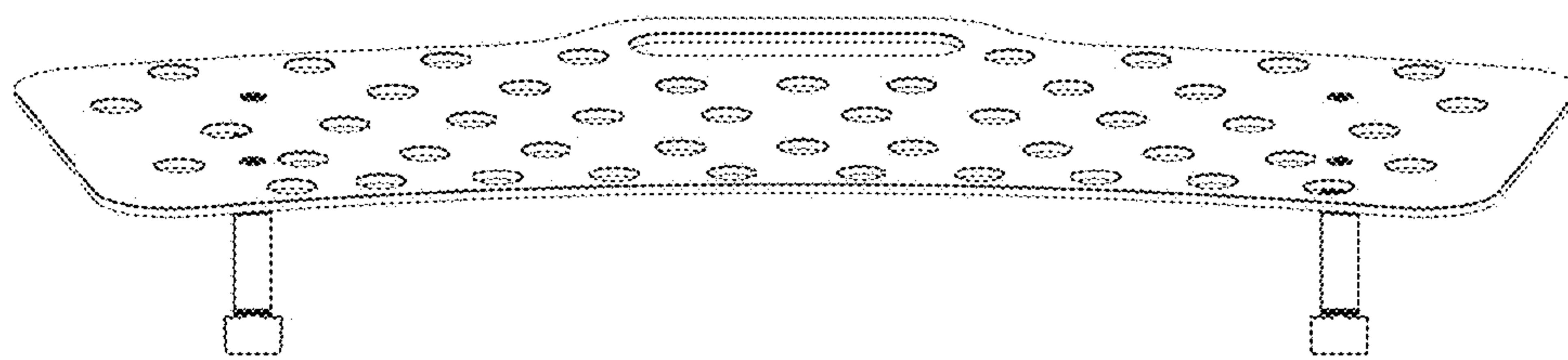



FIG. 3

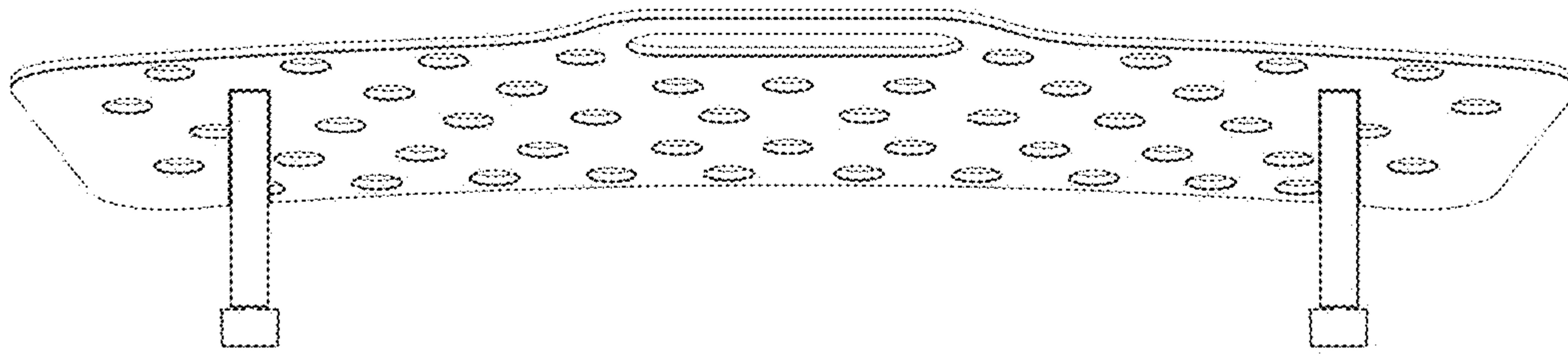

FIG. 4

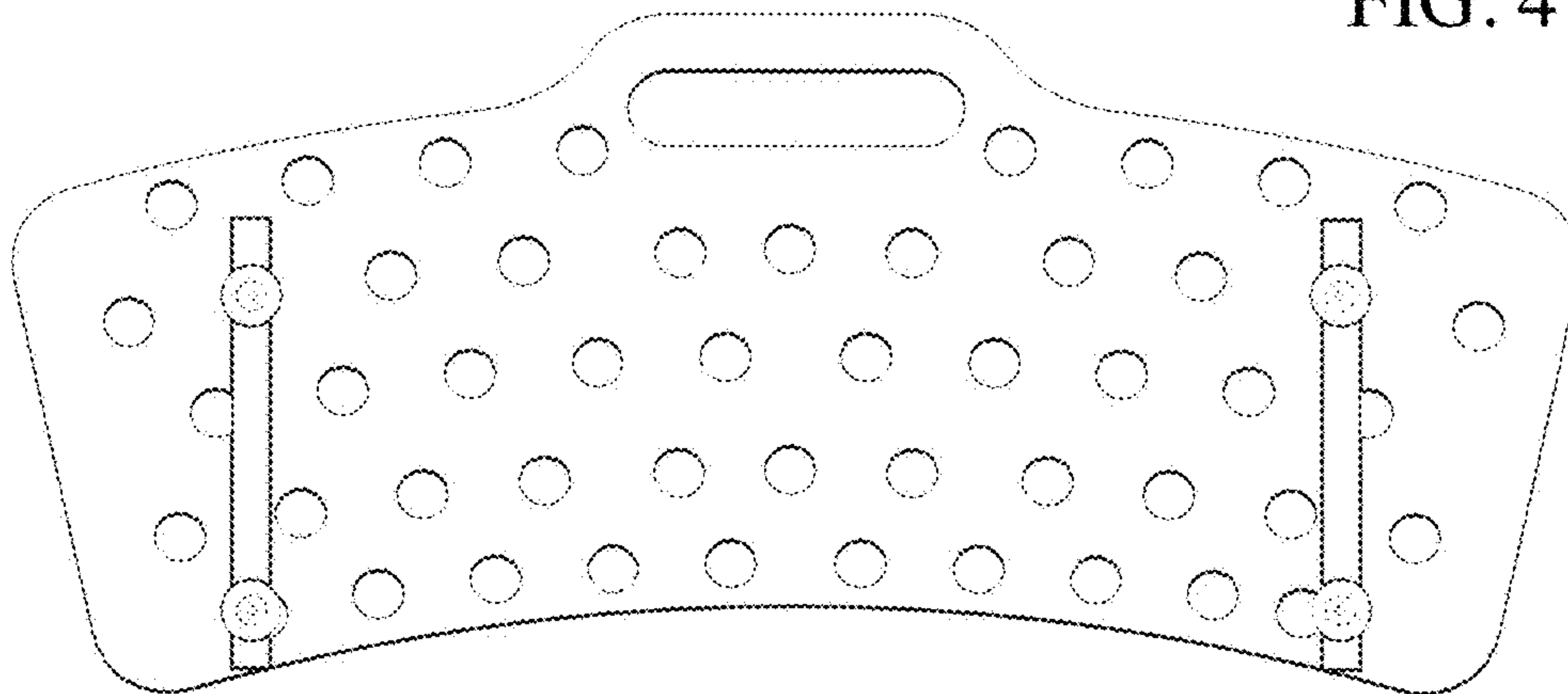

FIG. 5

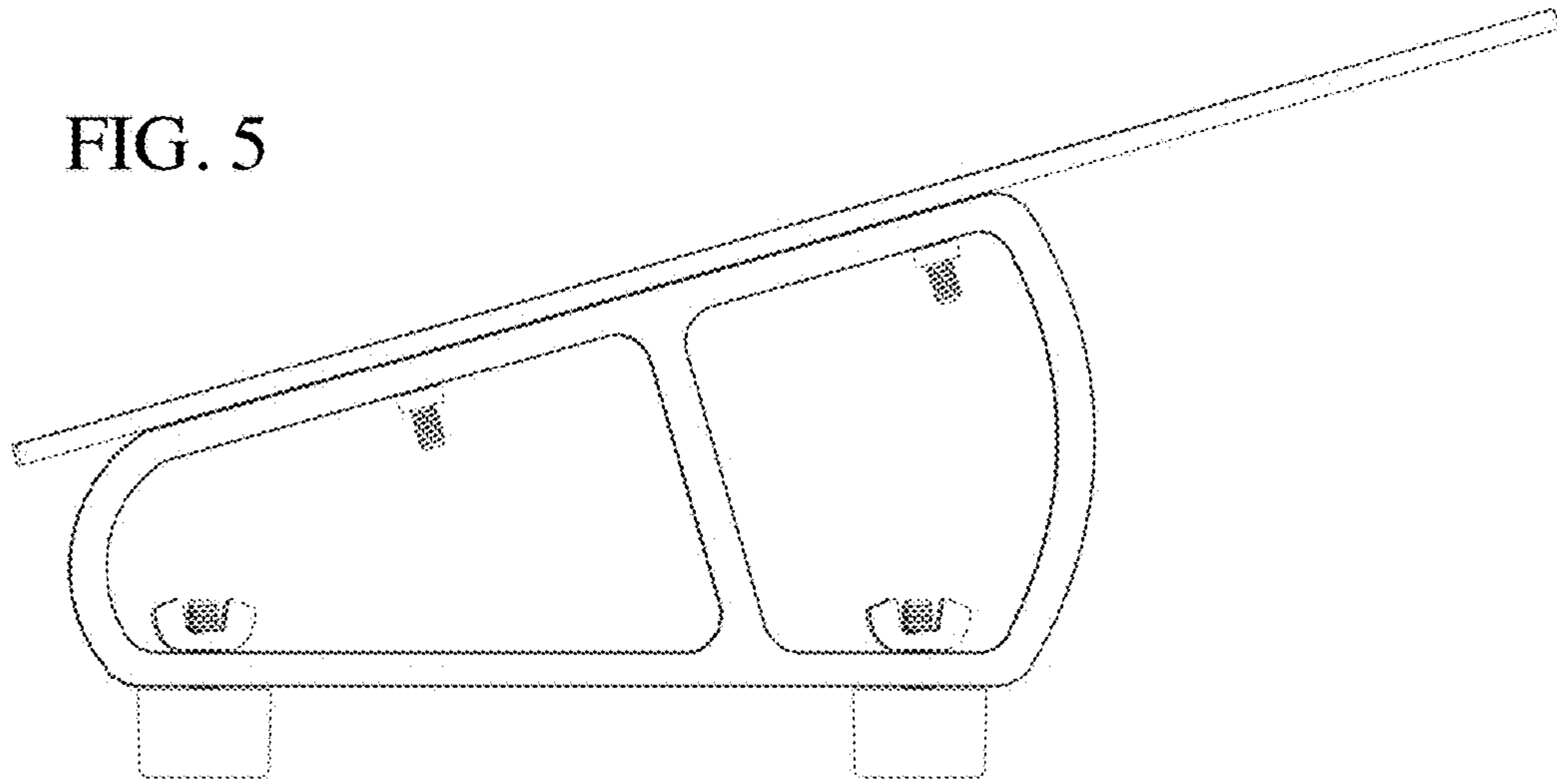

FIG. 6

