

US00D828143S

(12) **United States Design Patent** (10) **Patent No.:** **US D828,143 S**
Harrier (45) **Date of Patent:** **** Sep. 11, 2018**

(54) **CONNECTOR TAB FOR A REPAIR SUCH AS AN AUTOMOTIVE REPAIR**

(71) Applicant: **SERVICE KING PAINT & BODY, LLC, Richardson, TX (US)**

(72) Inventor: **Dustin Harrier, Surprise, AZ (US)**

(73) Assignee: **Service King Paint & Body, LLC, Richardson, TX (US)**

(**) Term: **15 Years**

(21) Appl. No.: **29/608,536**

(22) Filed: **Jun. 22, 2017**

(51) **LOC (11) Cl.** **08-08**

(52) **U.S. Cl.**
USPC **D8/349**

(58) **Field of Classification Search**
USPC D8/349, 354, 382, 383, 384, 400, 499;
156/94

CPC B29C 37/0082; B29C 37/00; B29C 43/18;
B29C 2035/0211; B29C 2035/0811;
B29C 2035/0816; B29C 73/12; B29C
73/025; B29C 73/00; B29C 73/04; B29C
73/066; B29C 73/08; B29C 73/30; B29C
73/34; B29C 67/0088; B29C 66/861;
B29C 66/9121; B29C 66/9141; B29C
66/71; B29C 65/525; B29C 65/4815;
B29C 65/18; B32B 27/12; B33Y 50/02;
B33Y 80/00; B29K 2101/12; B29L
2031/3055; B05C 17/0053; B05C
17/00546

See application file for complete search history.

(56) **References Cited**

U.S. PATENT DOCUMENTS

3,112,563 A 12/1963 Kamborian et al.
4,822,671 A 4/1989 Carper et al.
4,865,680 A * 9/1989 Pierson B29C 65/08
156/497
5,433,038 A 7/1995 Dupuy

5,492,842 A * 2/1996 Eytcheson H02M 7/003
29/593
5,782,575 A * 7/1998 Vincent A61M 5/152
156/580.2
6,431,409 B1 8/2002 Gehde et al.
D481,684 S * 11/2003 Bomar D13/154
D497,993 S * 11/2004 Dixon D24/155
D499,383 S * 12/2004 Bomar D13/154
7,063,811 B2 6/2006 Brozenick et al.
D567,401 S * 4/2008 Mason, II D26/24
7,429,023 B2 * 9/2008 Morrow E04B 1/003
248/200
7,905,267 B2 3/2011 Arnold
7,950,186 B2 5/2011 Gross et al.
8,070,204 B2 12/2011 Mourou
8,235,444 B2 8/2012 Eidt et al.
8,250,725 B2 * 8/2012 Sigler B29C 37/0085
156/293
D707,830 S * 6/2014 Klutts D24/190
D707,831 S * 6/2014 Klutts D24/190
D729,745 S * 5/2015 Vanderwoud D13/154
9,259,867 B2 * 2/2016 Richardson B29C 37/0085
D765,843 S * 9/2016 Breault D24/155
D810,162 S * 2/2018 Thweatt, Jr. D15/144
2004/0033336 A1 * 2/2004 Schulte A44B 18/0049
428/100
2009/0021053 A1 1/2009 Harberts et al.
2011/0233802 A1 9/2011 Estrate
2012/0034373 A1 2/2012 Liddell et al.
2015/0001768 A1 1/2015 Kia et al.
2015/0021942 A1 1/2015 Evans
2015/0059958 A1 3/2015 Wang
2015/0331402 A1 11/2015 Lin et al.
2016/0039157 A1 2/2016 Huang et al.
2016/0121585 A1 5/2016 Jennings et al.
2016/0176084 A1 6/2016 Altonen et al.
2016/0221278 A1 8/2016 Herrmann et al.
2017/0194721 A1 * 7/2017 Fan H01R 4/04
2017/0368770 A1 * 12/2017 Harrier B29C 73/12
2017/0368771 A1 * 12/2017 Harrier B29C 73/12

FOREIGN PATENT DOCUMENTS

CN 201751172 U 2/2011
CN 104416909 A 3/2015
CN 104881513 A 9/2015
CN 205097539 U 3/2016
DE 19836313 A1 2/2000
DE 102013112933 A1 5/2015
FR 2694518 A1 2/1994
WO WO 2015/049088 4/2015

* cited by examiner

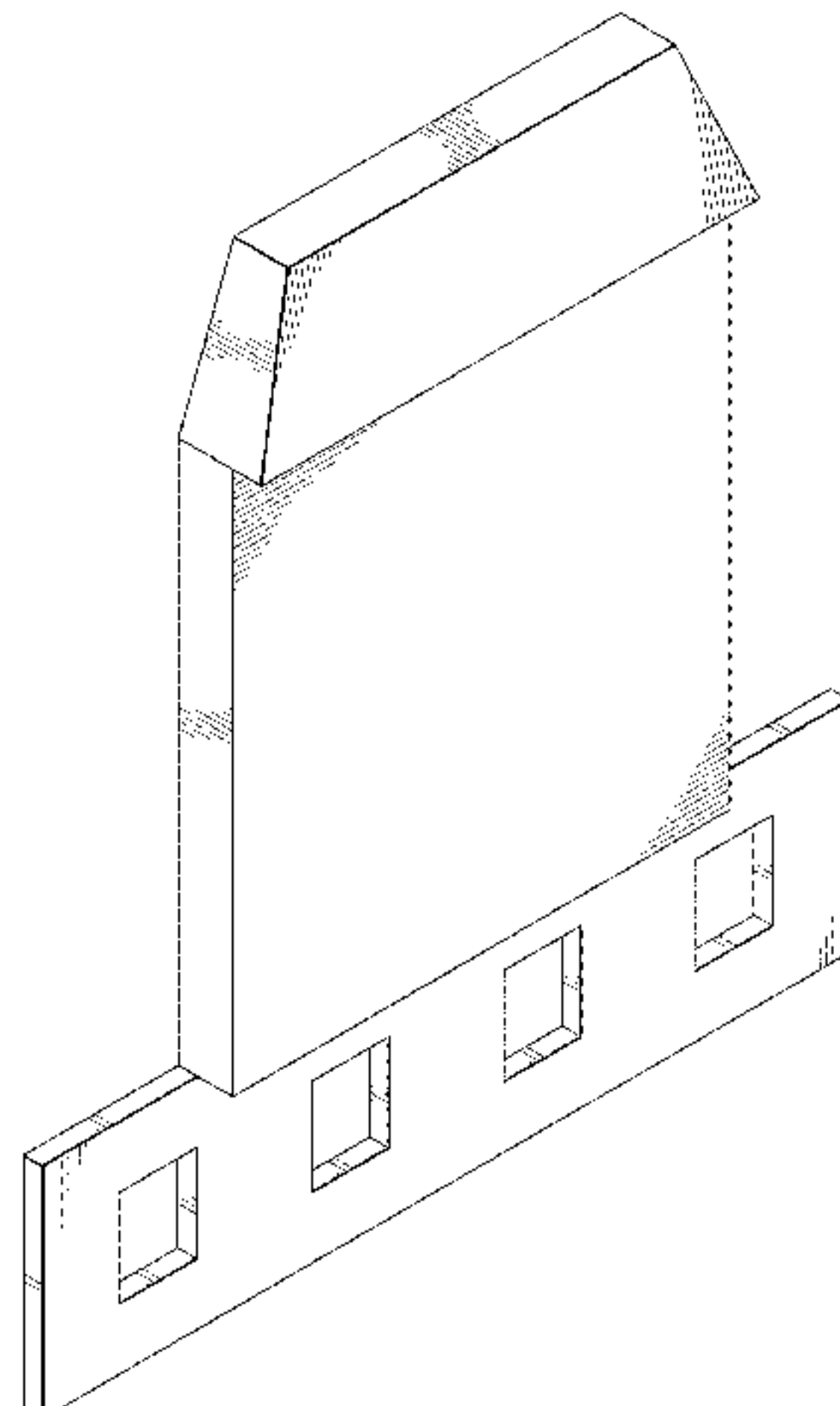

Primary Examiner — Mark Goodwin
 (74) *Attorney, Agent, or Firm* — Haynes and Boone, LLP

(57) **CLAIM**

The ornamental design for a connector tab for a repair such as an automotive repair, as shown and described.

DESCRIPTION

This application is related to U.S. patent application Ser. No. 15/630,749, filed Jun. 22, 2017, the entire disclosure of which is hereby incorporated herein by reference.

This application is related to U.S. patent application Ser. No. 15/630,809, filed Jun. 22, 2017, the entire disclosure of which is hereby incorporated herein by reference.

This application is related to U.S. patent application Ser. No. 29/608,522, filed Jun. 22, 2017, the entire disclosure of which is hereby incorporated herein by reference.

This application is related to U.S. patent application Ser. No. 29/608,569, filed Jun. 22, 2017, the entire disclosure of which is hereby incorporated herein by reference.

FIG. 1 is a front perspective view of a connector tab for a repair such as an automotive repair showing my new design according to a first embodiment;

FIG. 2 is a front elevational view of the first embodiment;

FIG. 3 is a rear elevational view of the first embodiment;

FIG. 4 is a right side elevational view of the first embodiment;

FIG. 5 is a left side elevational view of the first embodiment;

FIG. 6 is a top plan view of the first embodiment;

FIG. 7 is a bottom plan view of the first embodiment;

FIG. 8 is a rear perspective view of the first embodiment;

FIG. 9 is a front elevational view of the connector tab for a repair such as an automotive repair showing my new design according to a second embodiment, the second embodiment being identical to the first embodiment except that the second embodiment has one indeterminate length as indicated in FIG. 9;

FIG. 10 is a front elevational view of the connector tab for a repair such as an automotive repair showing my new design according to a third embodiment, the third embodiment being identical to the first embodiment except that the third embodiment has one indeterminate length as indicated in FIG. 10;

FIG. 11 is a front perspective view of the connector tab for a repair such as an automotive repair showing my new design according to a fourth embodiment;

FIG. 12 is a front elevational view of the fourth embodiment;

FIG. 13 is a rear elevational view of the fourth embodiment;

FIG. 14 is a right side elevational view of the fourth embodiment;

FIG. 15 is a left side elevational view of the fourth embodiment;

FIG. 16 is a top plan view of the fourth embodiment;

FIG. 17 is a bottom plan view of the fourth embodiment;

FIG. 18 is a rear perspective view of the fourth embodiment;

FIG. 19 is a front elevational view of the connector tab for a repair such as an automotive repair showing my new design according to a fifth embodiment, the fifth embodiment being identical to the fourth embodiment except that the fifth embodiment has one indeterminate length as indicated in FIG. 19;

FIG. 20 is a front elevational view of the connector tab for a repair such as an automotive repair showing my new

design according to a sixth embodiment, the sixth embodiment being identical to the fourth embodiment except that the sixth embodiment has one indeterminate length as indicated in FIG. 20;

FIG. 21 is a front perspective view of the connector tab for a repair such as an automotive repair showing my new design according to a seventh embodiment;

FIG. 22 is a front elevational view of the seventh embodiment;

FIG. 23 is a rear elevational view of the seventh embodiment;

FIG. 24 is a right side elevational view of the seventh embodiment;

FIG. 25 is a left side elevational view of the seventh embodiment;

FIG. 26 is a top plan view of the seventh embodiment;

FIG. 27 is a bottom plan view of the seventh embodiment;

FIG. 28 is a rear perspective view of the seventh embodiment;

FIG. 29 is a front elevational view of the connector tab for a repair such as an automotive repair showing my new design according to an eighth embodiment, the eighth embodiment being identical to the seventh embodiment except that the eighth embodiment has one indeterminate length as indicated in FIG. 29; and,

FIG. 30 is a front elevational view of the connector tab for a repair such as an automotive repair showing my new design according to a ninth embodiment, the ninth embodiment being identical to the seventh embodiment except that the ninth embodiment has one indeterminate length as indicated in FIG. 30.

In FIG. 9, the second embodiment of the connector tab for a repair such as an automotive repair is shown with break lines to indicate the one indeterminate length in FIG. 9; the appearance of any portion of the second embodiment of the connector tab for a repair such as an automotive repair between the break lines forms no part of the claimed design.

In FIG. 10, the third embodiment of the connector tab for a repair such as an automotive repair is shown with break lines to indicate the one indeterminate length in FIG. 10; the appearance of any portion of the third embodiment of the connector tab for a repair such as an automotive repair between the break lines forms no part of the claimed design.

In FIG. 19, the fifth embodiment of the connector tab for a repair such as an automotive repair is shown with break lines to indicate the one indeterminate length in FIG. 19; the appearance of any portion of the fifth embodiment of the connector tab for a repair such as an automotive repair between the break lines forms no part of the claimed design.

In FIG. 20, the sixth embodiment of the connector tab for a repair such as an automotive repair is shown with break lines to indicate the one indeterminate length in FIG. 20; the appearance of any portion of the sixth embodiment of the connector tab for a repair such as an automotive repair between the break lines forms no part of the claimed design.

In FIG. 29, the eighth embodiment of the connector tab for a repair such as an automotive repair is shown with break lines to indicate the one indeterminate length in FIG. 29; the appearance of any portion of the eighth embodiment of the connector tab for a repair such as an automotive repair between the break lines forms no part of the claimed design.

In FIG. 30, the ninth embodiment of the connector tab for a repair such as an automotive repair is shown with break lines to indicate the one indeterminate length in FIG. 30; the appearance of any portion of the ninth embodiment of the

connector tab for a repair such as an automotive repair between the break lines forms no part of the claimed design.

1 Claim, 24 Drawing Sheets

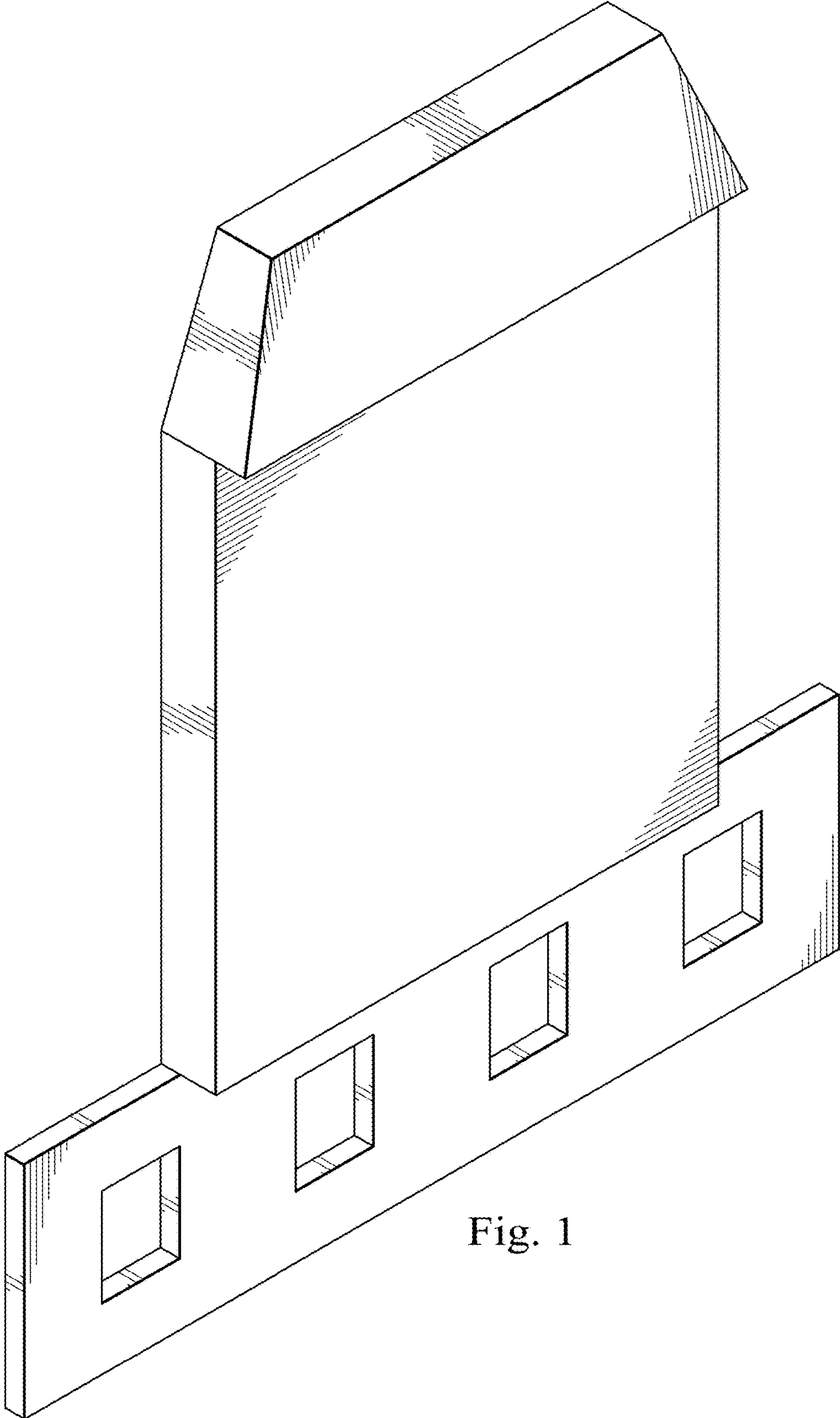

Fig. 1

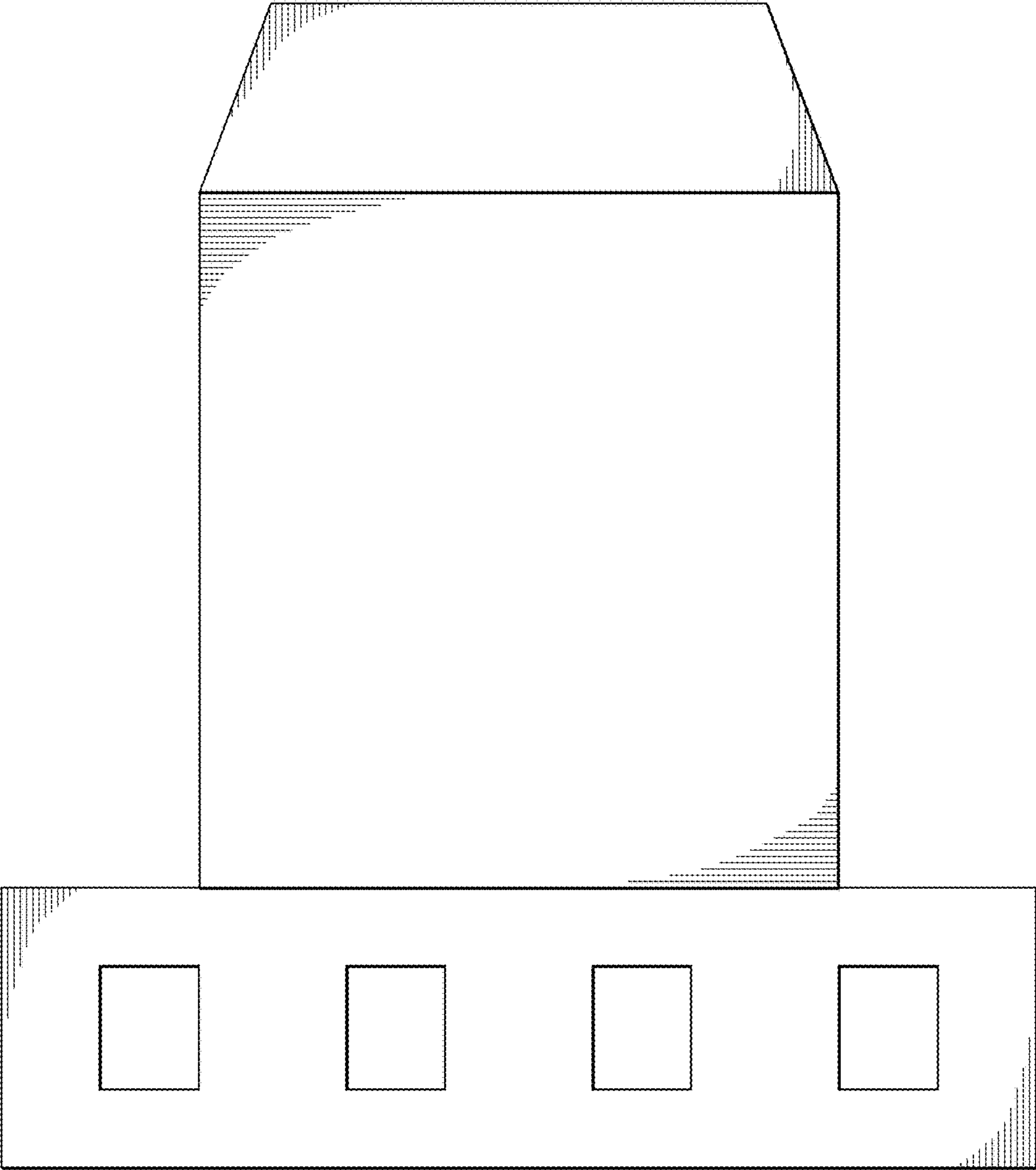

Fig. 2

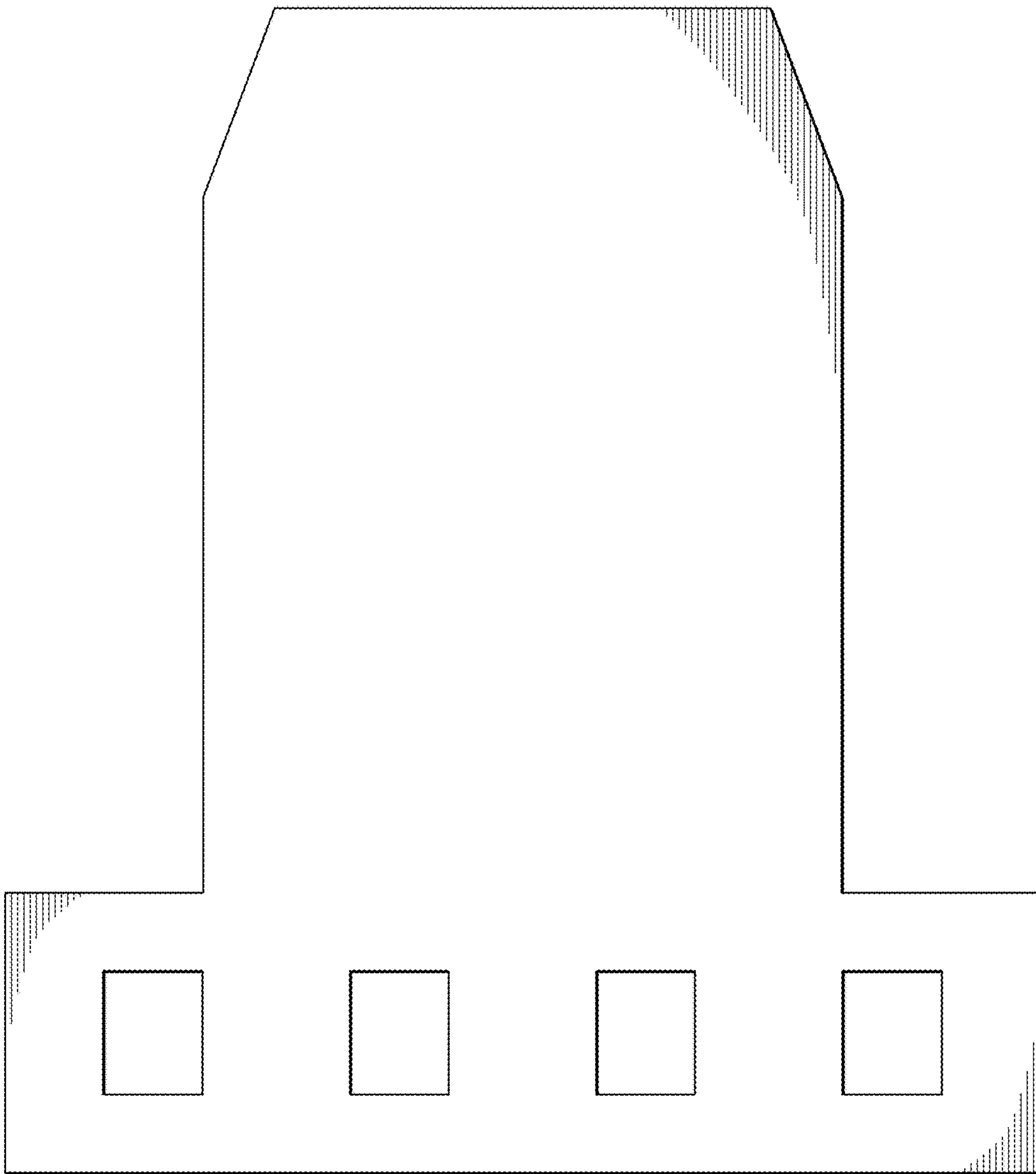

Fig. 3

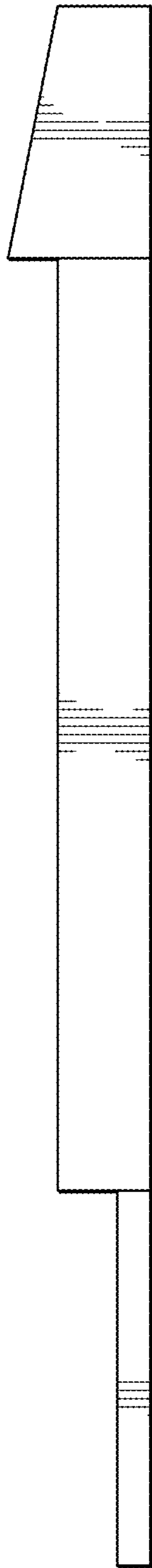

Fig. 4

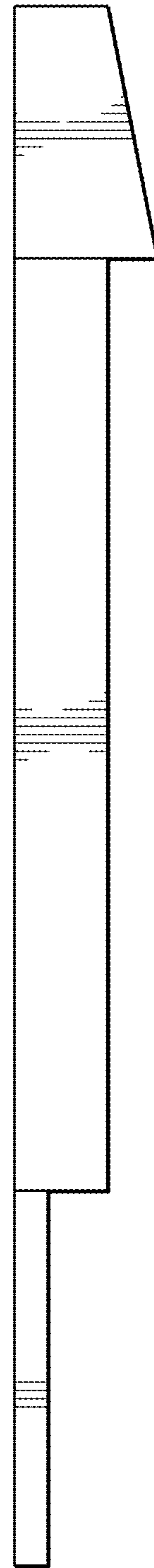

Fig. 5

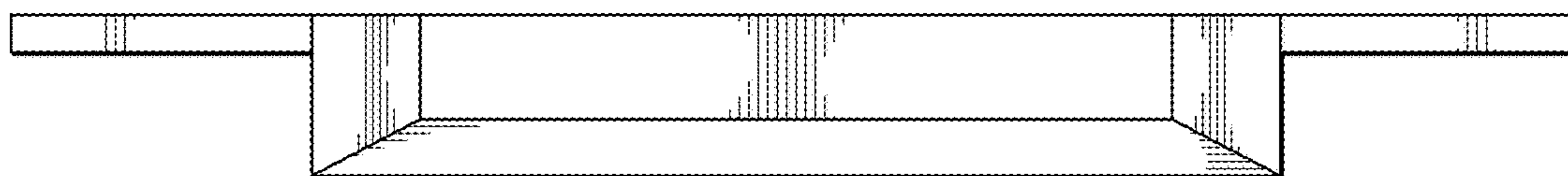

Fig. 6

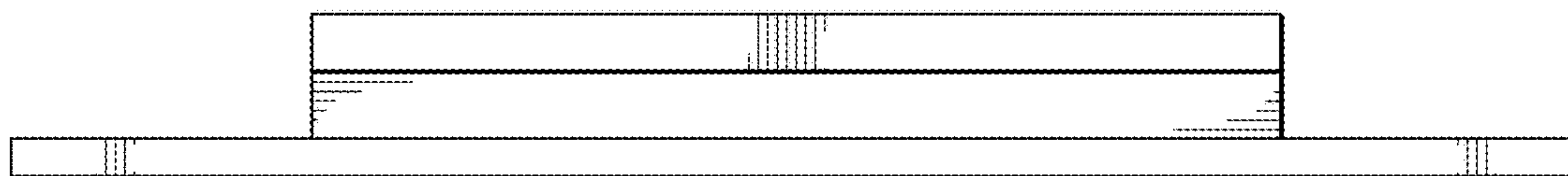

Fig. 7

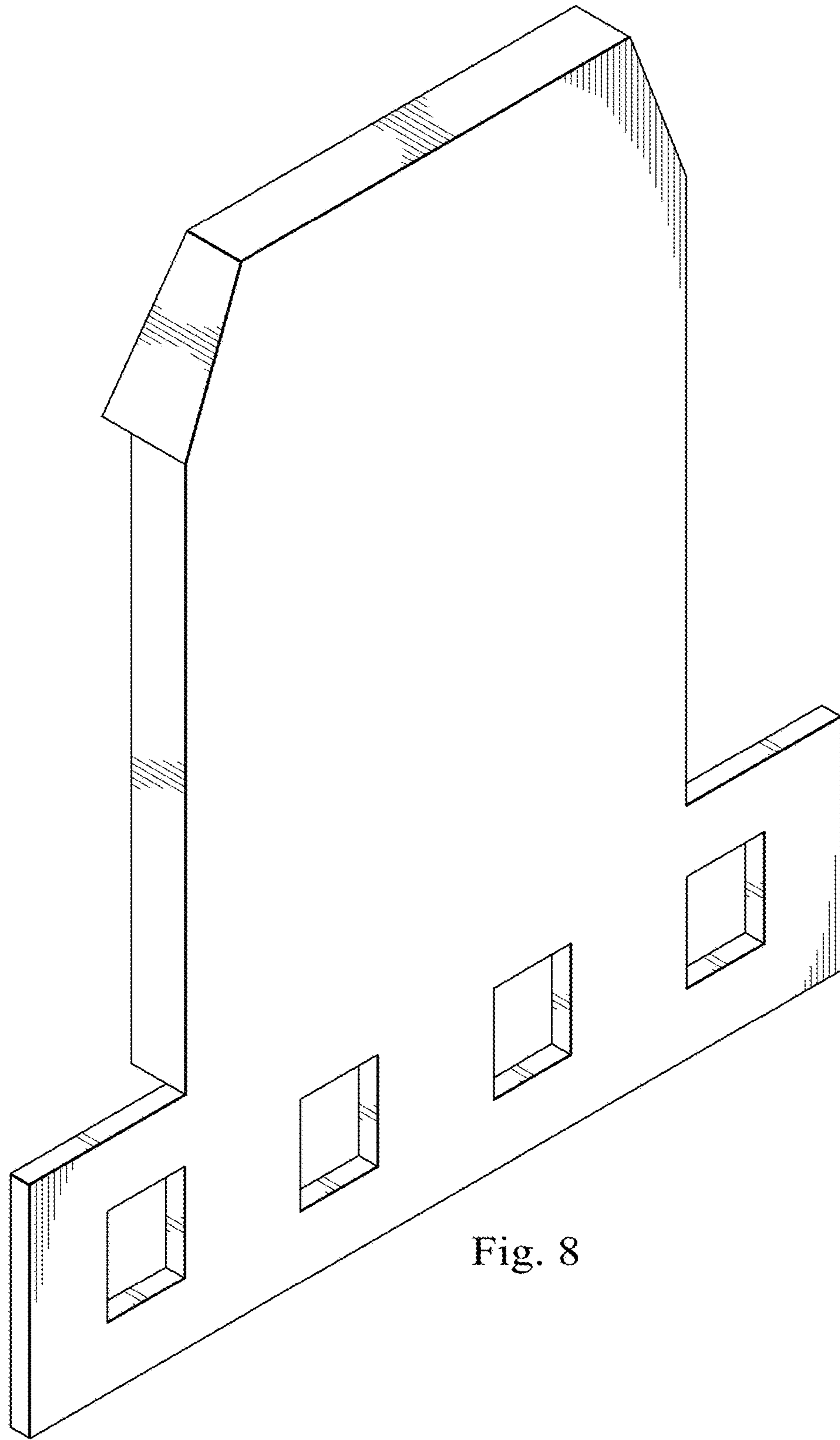

Fig. 8

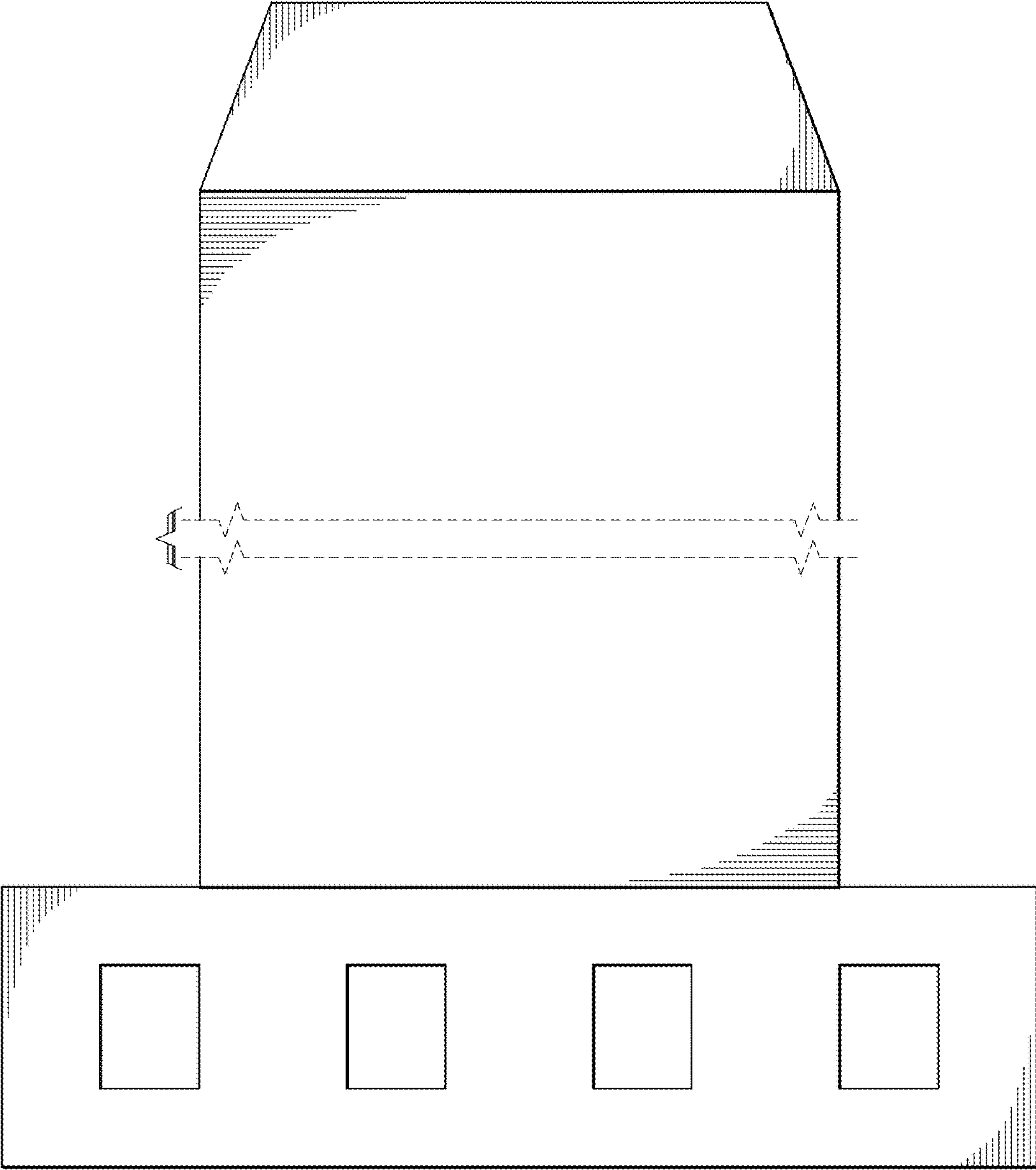

Fig. 9

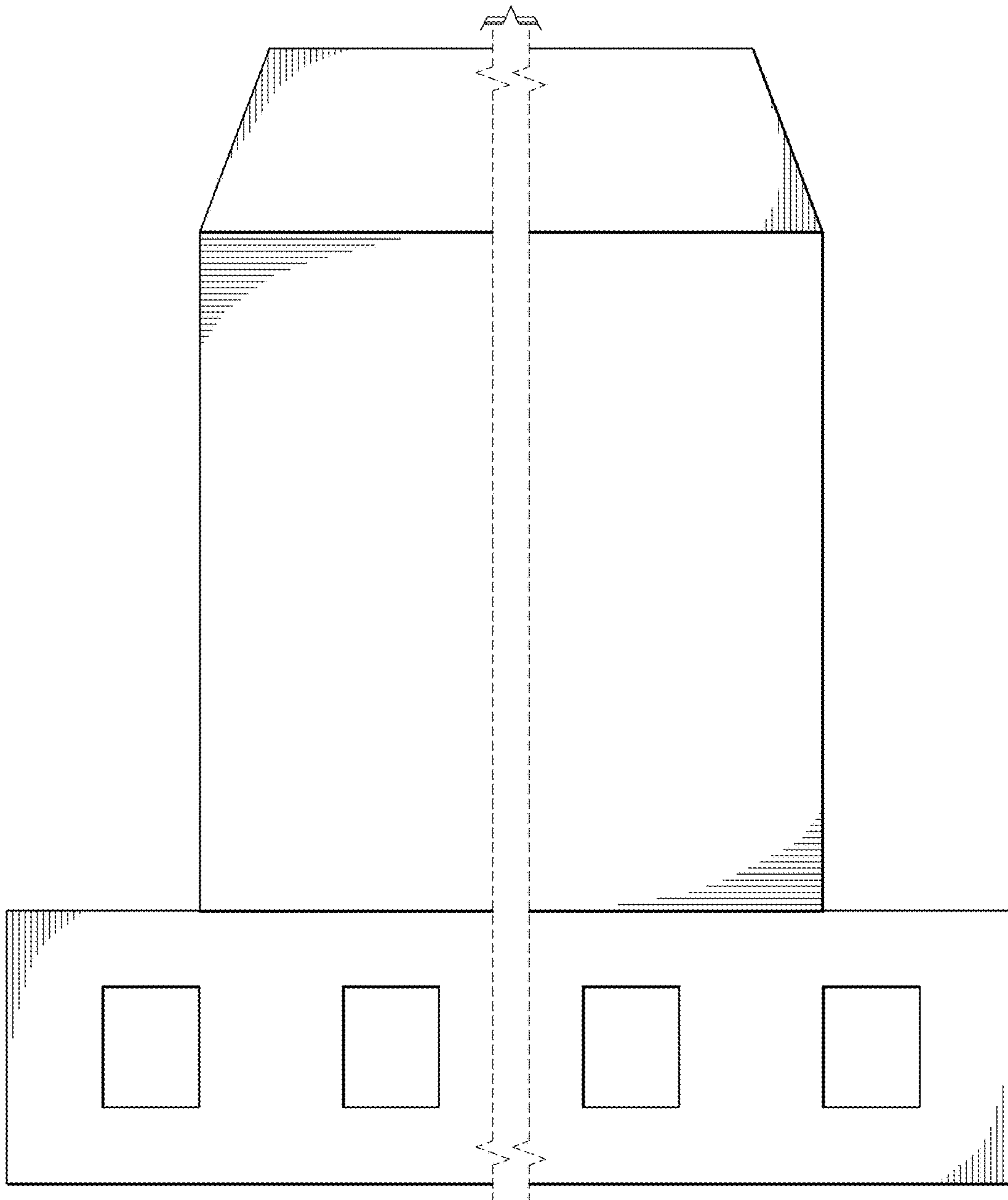

Fig. 10

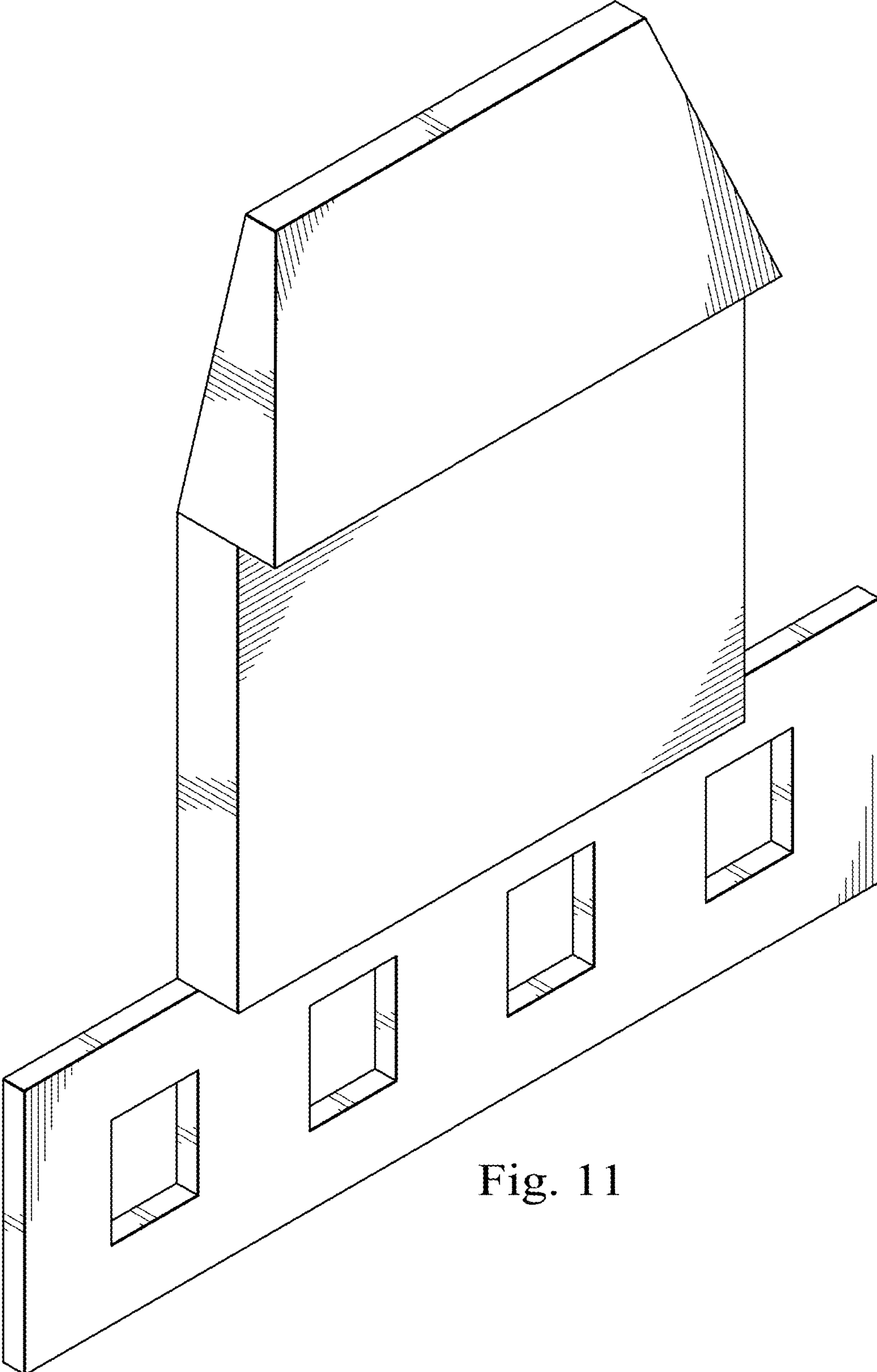

Fig. 11

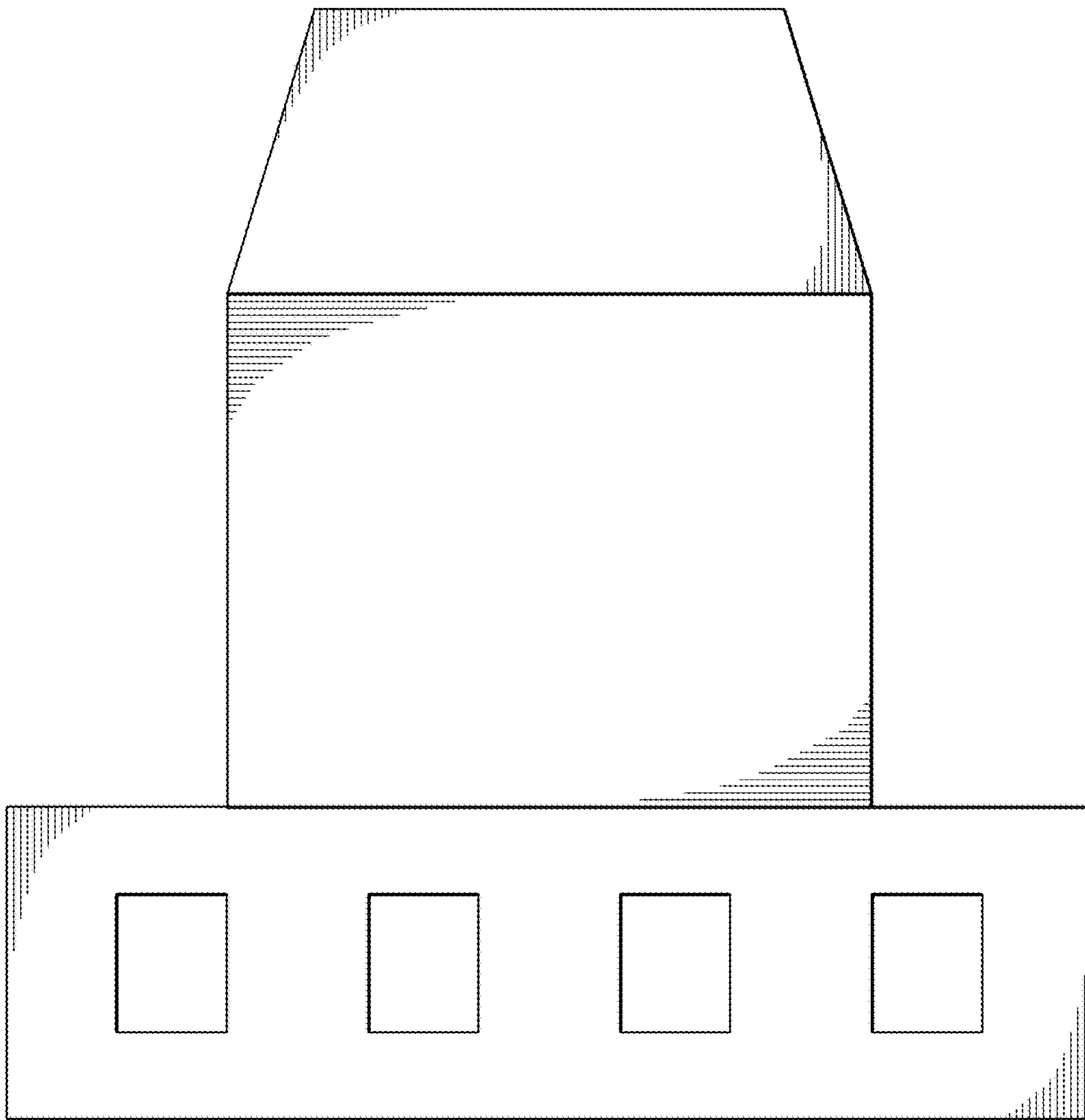

Fig. 12

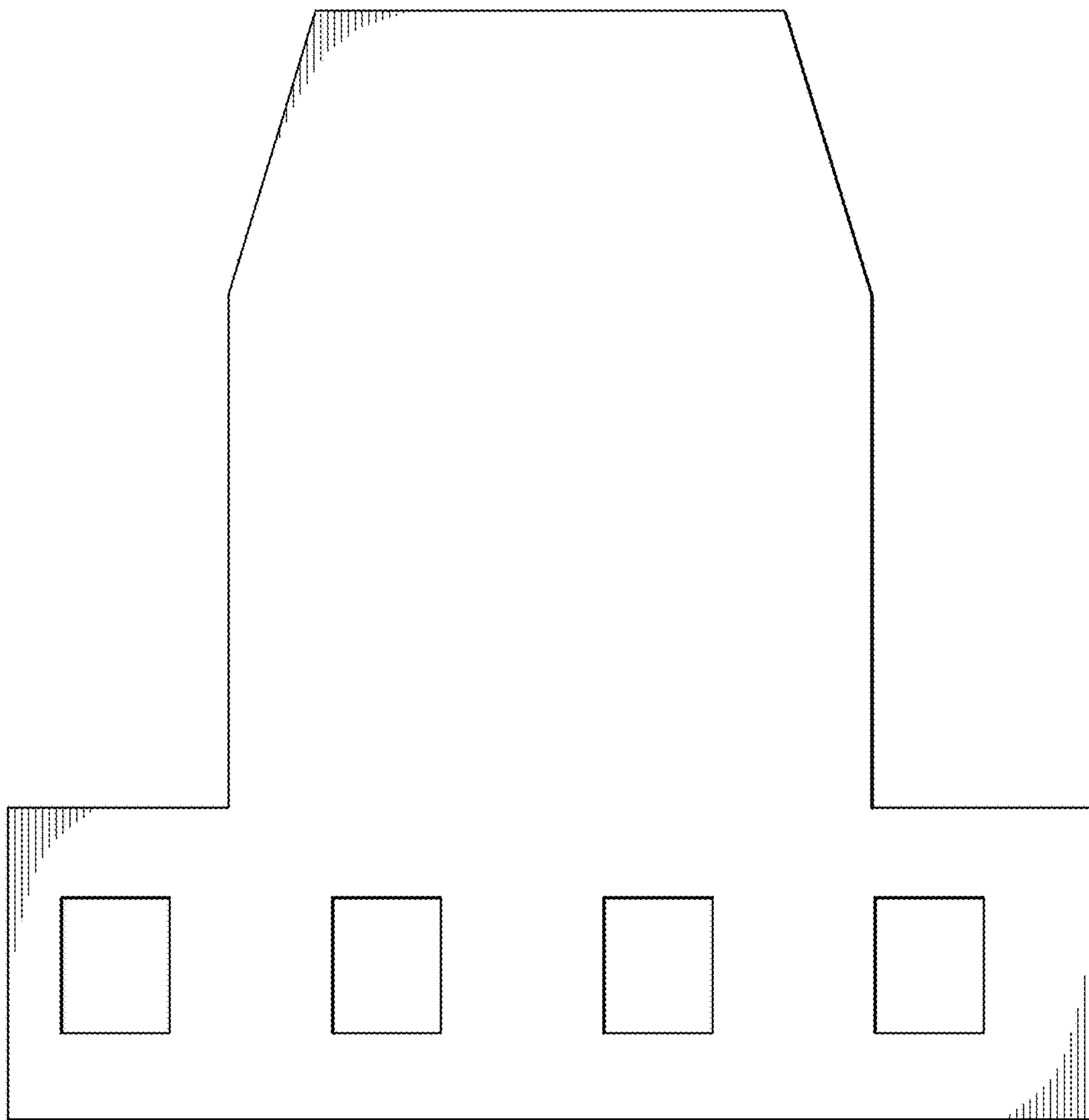

Fig. 13

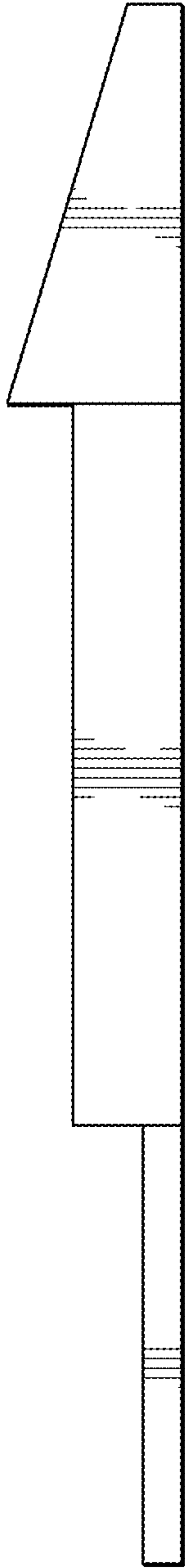

Fig. 14

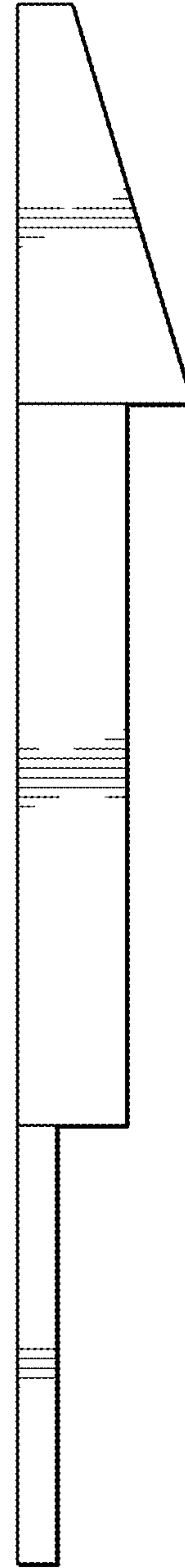

Fig. 15

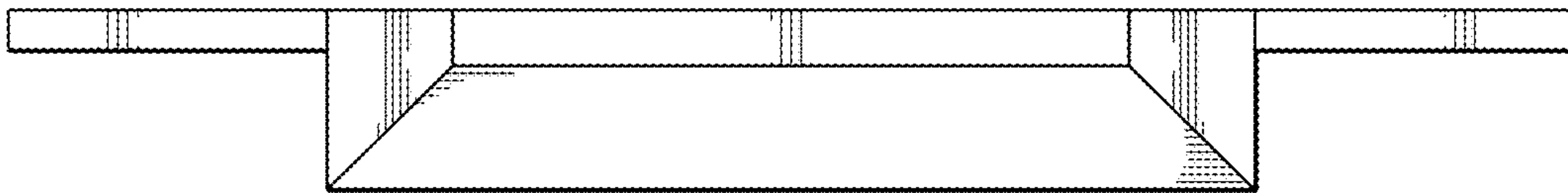

Fig. 16

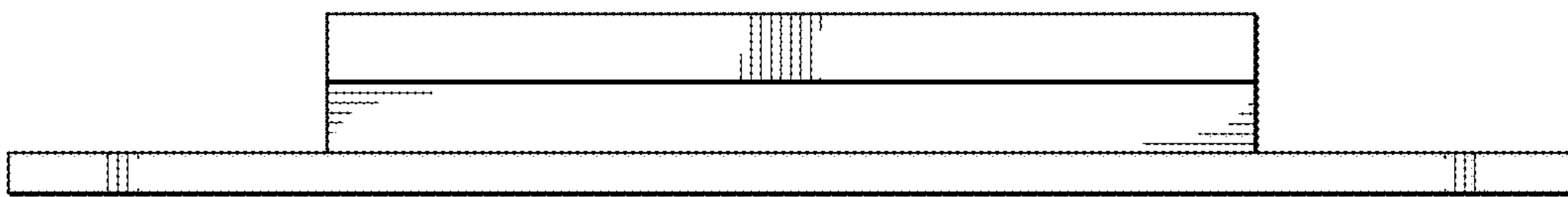

Fig. 17

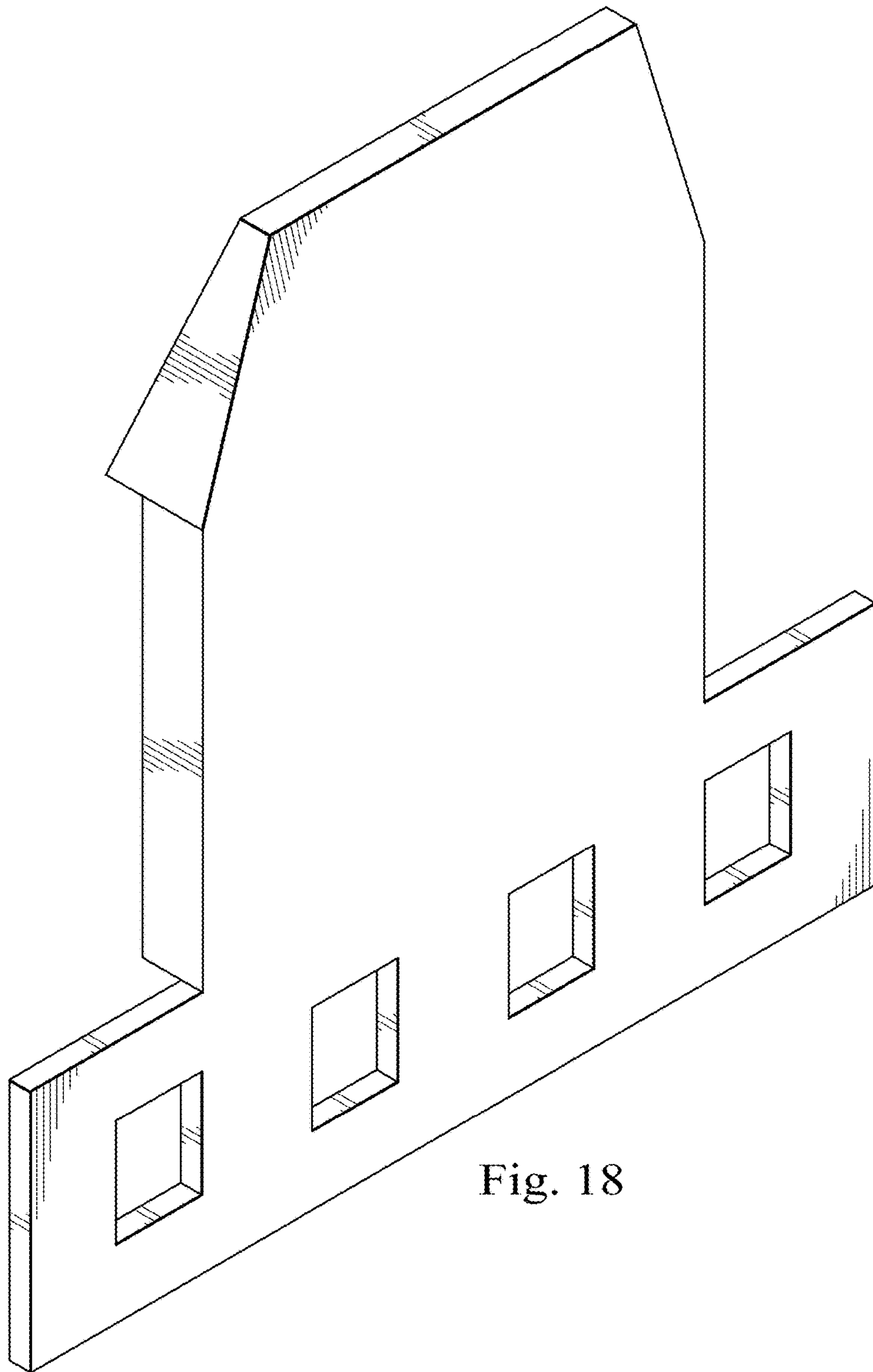

Fig. 18

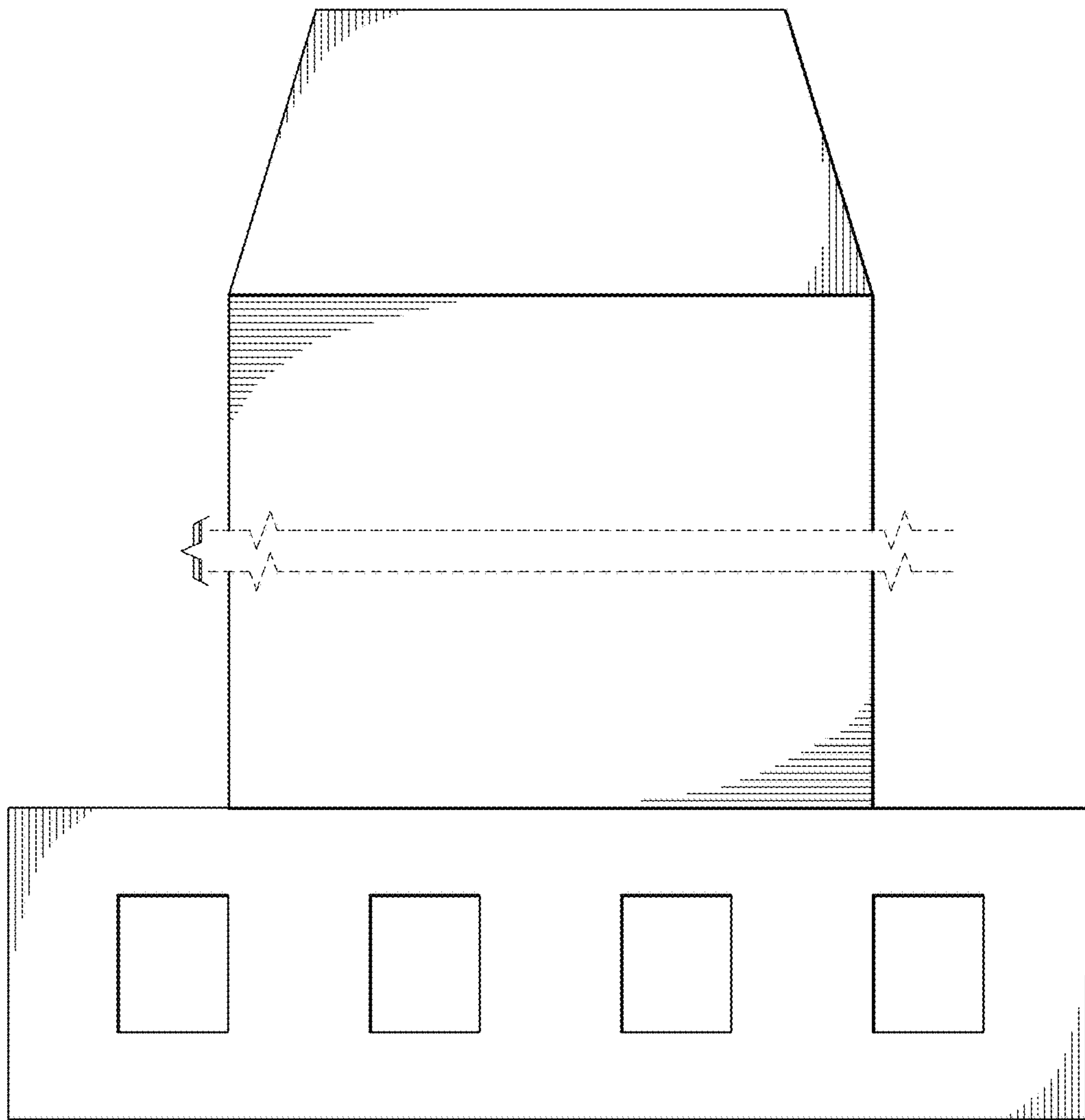

Fig. 19

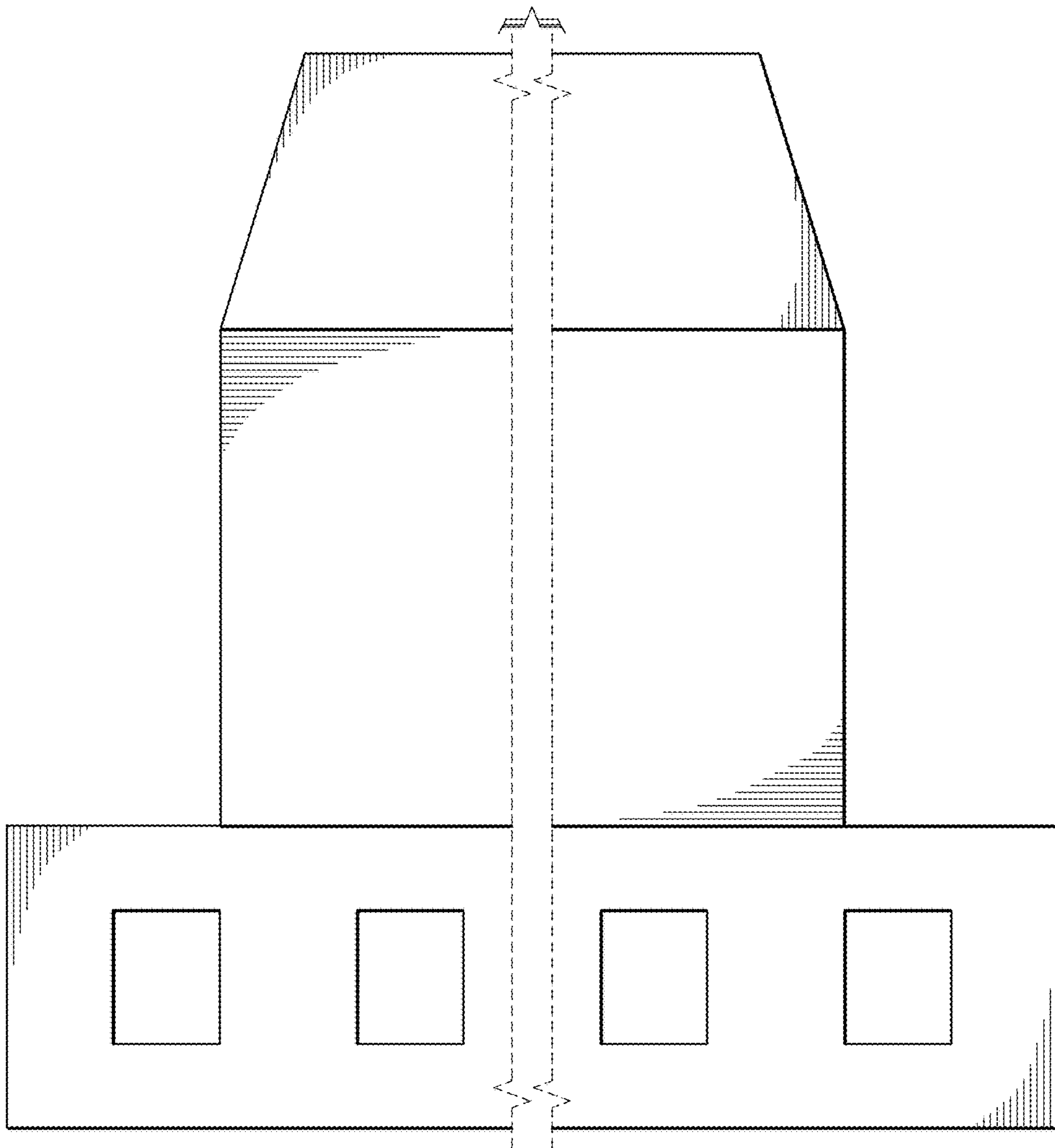

Fig. 20

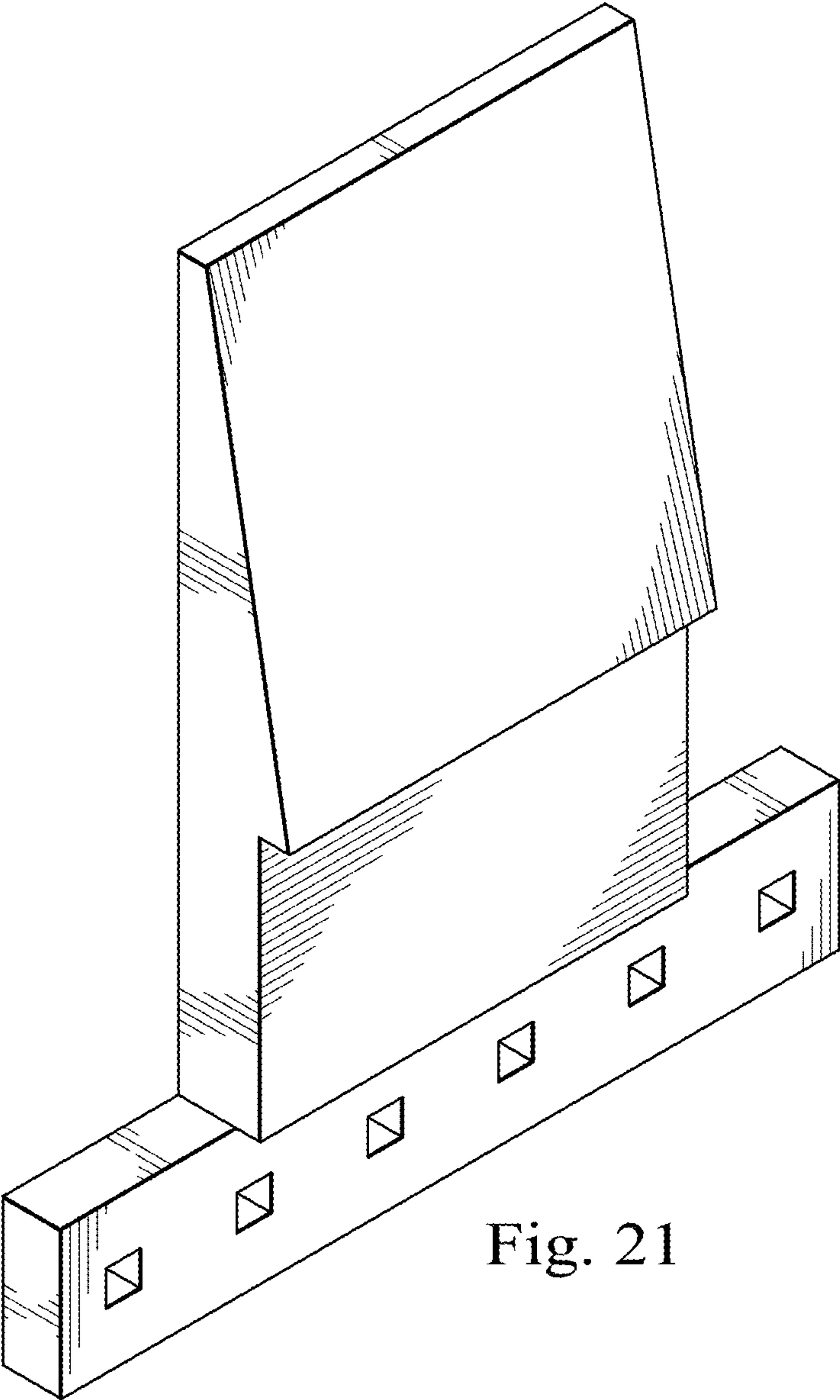

Fig. 21

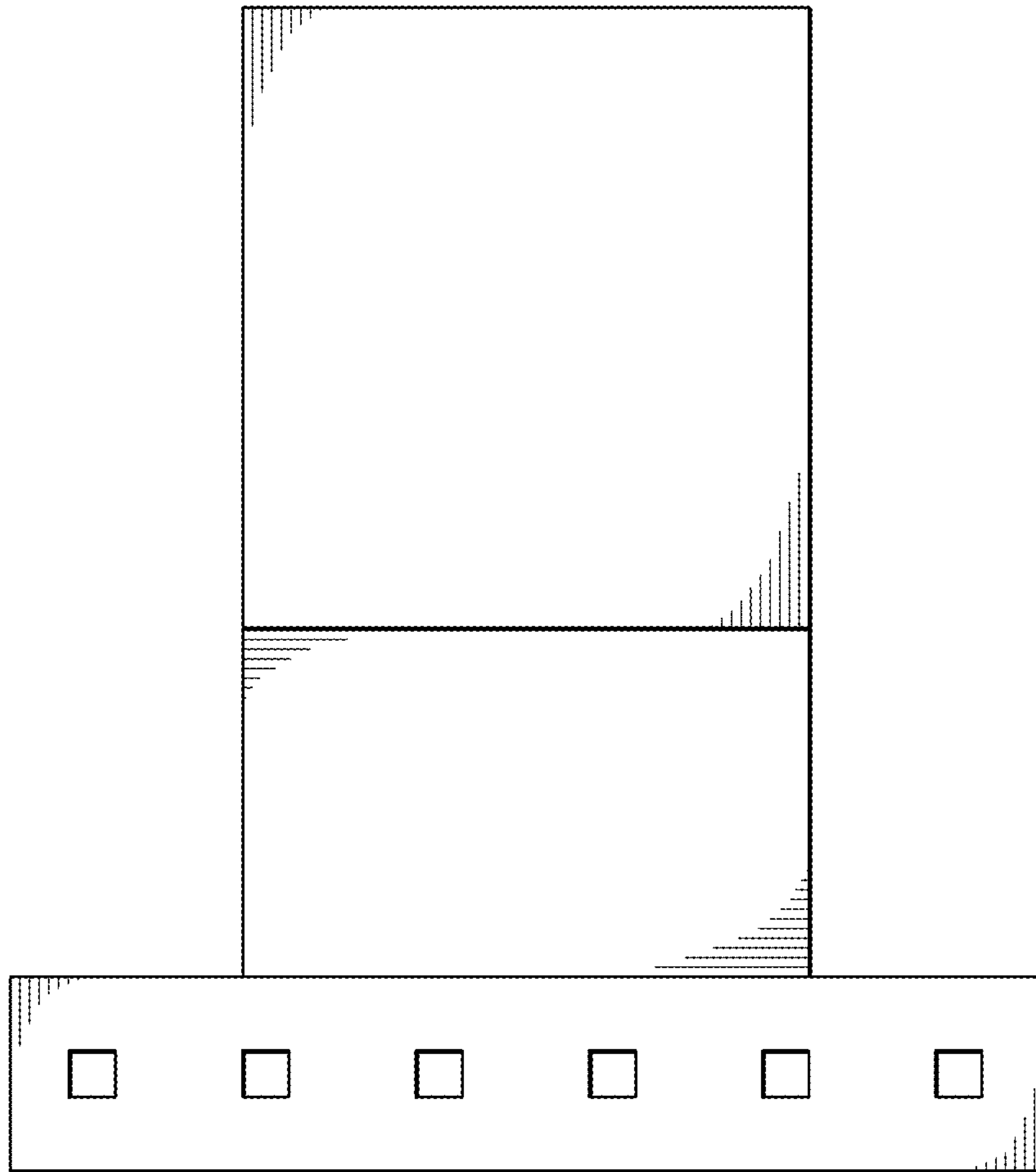

Fig. 22

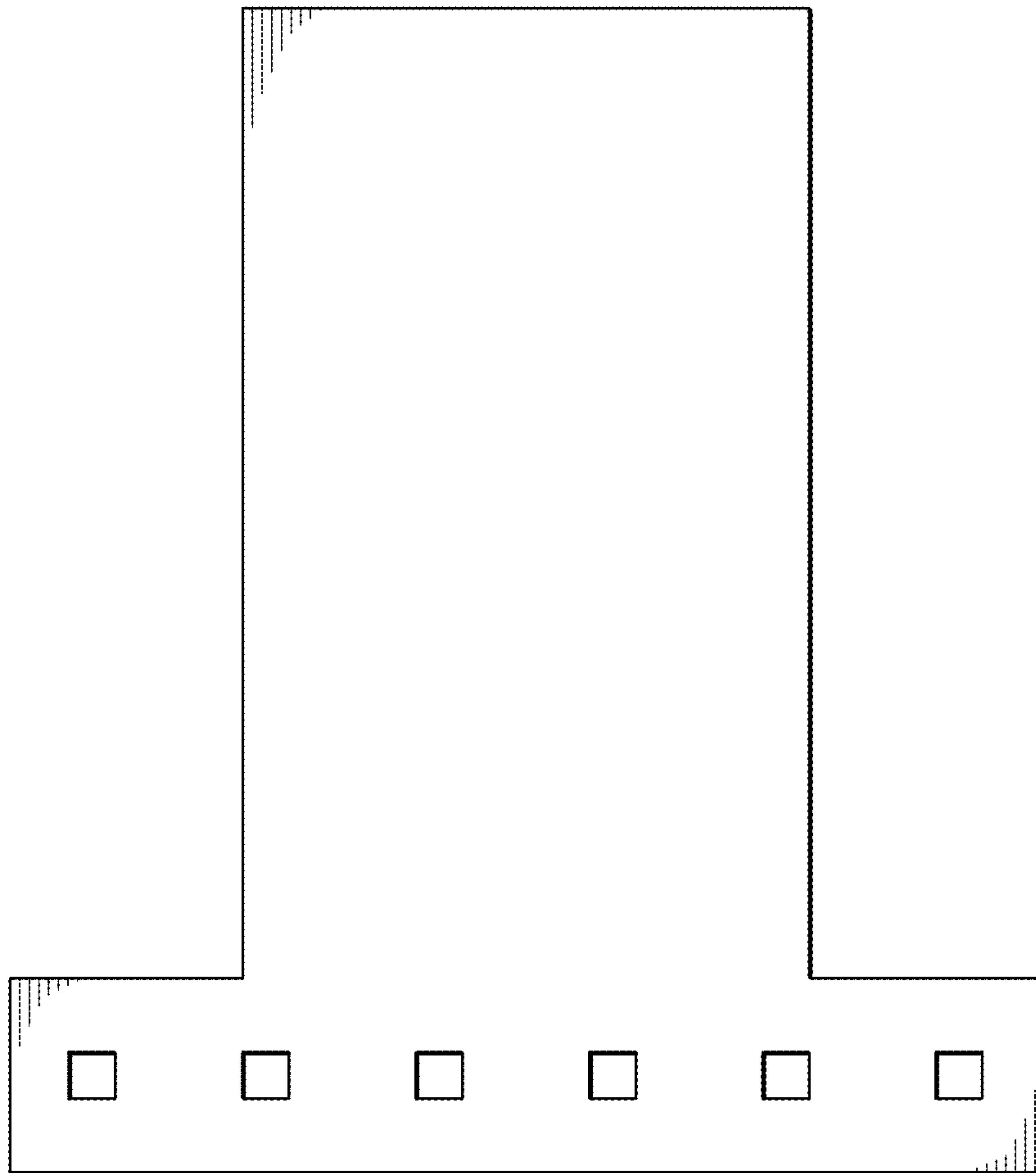

Fig. 23

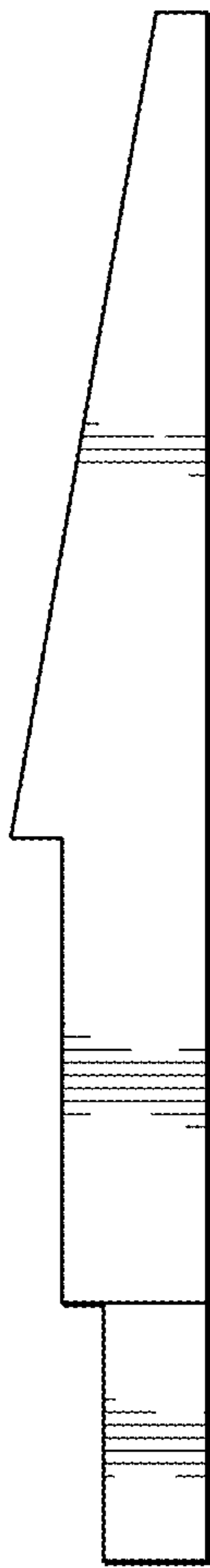

Fig. 24

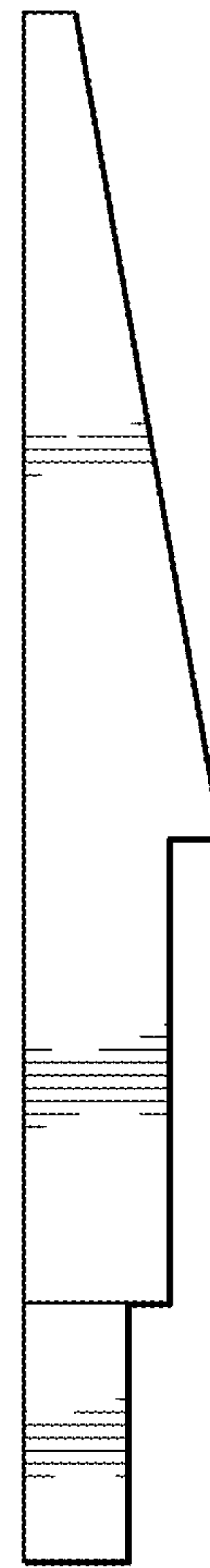

Fig. 25

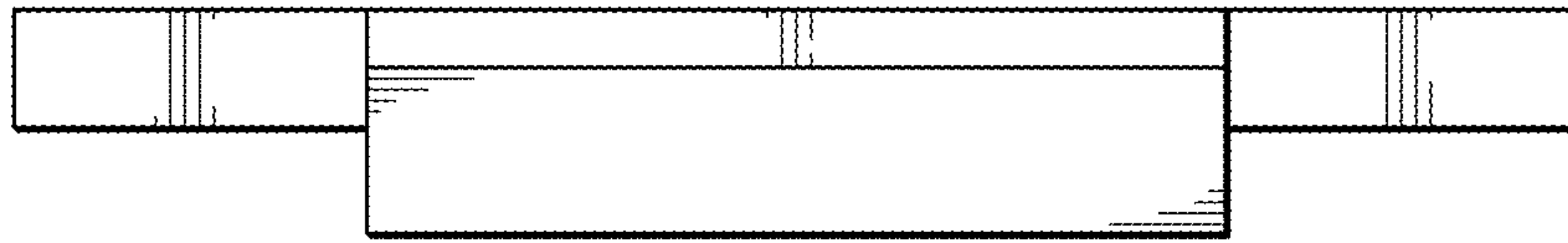

Fig. 26

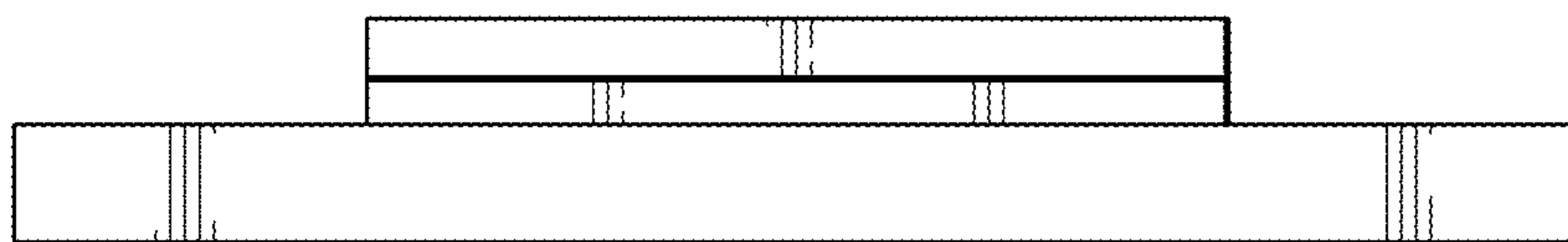

Fig. 27

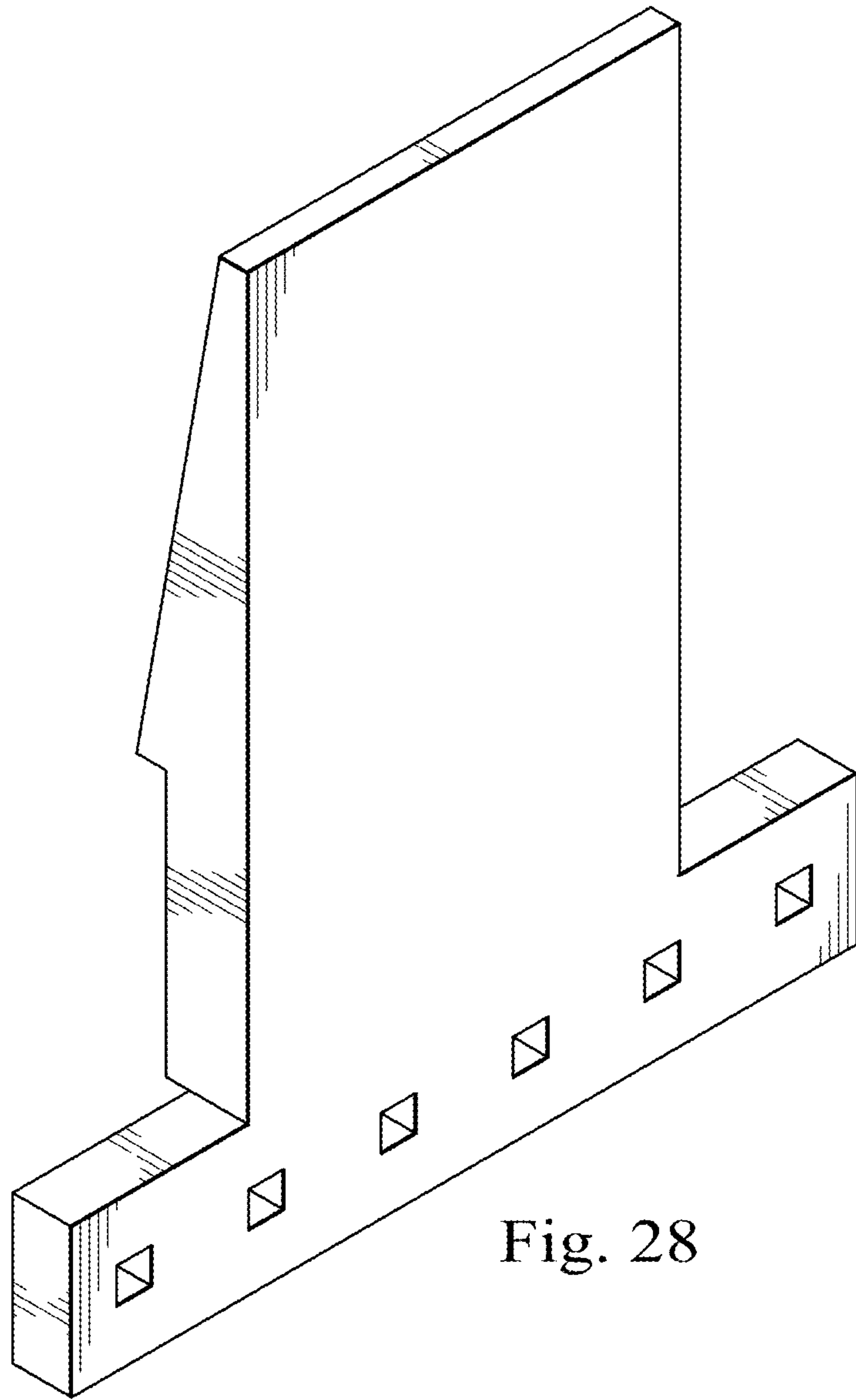

Fig. 28

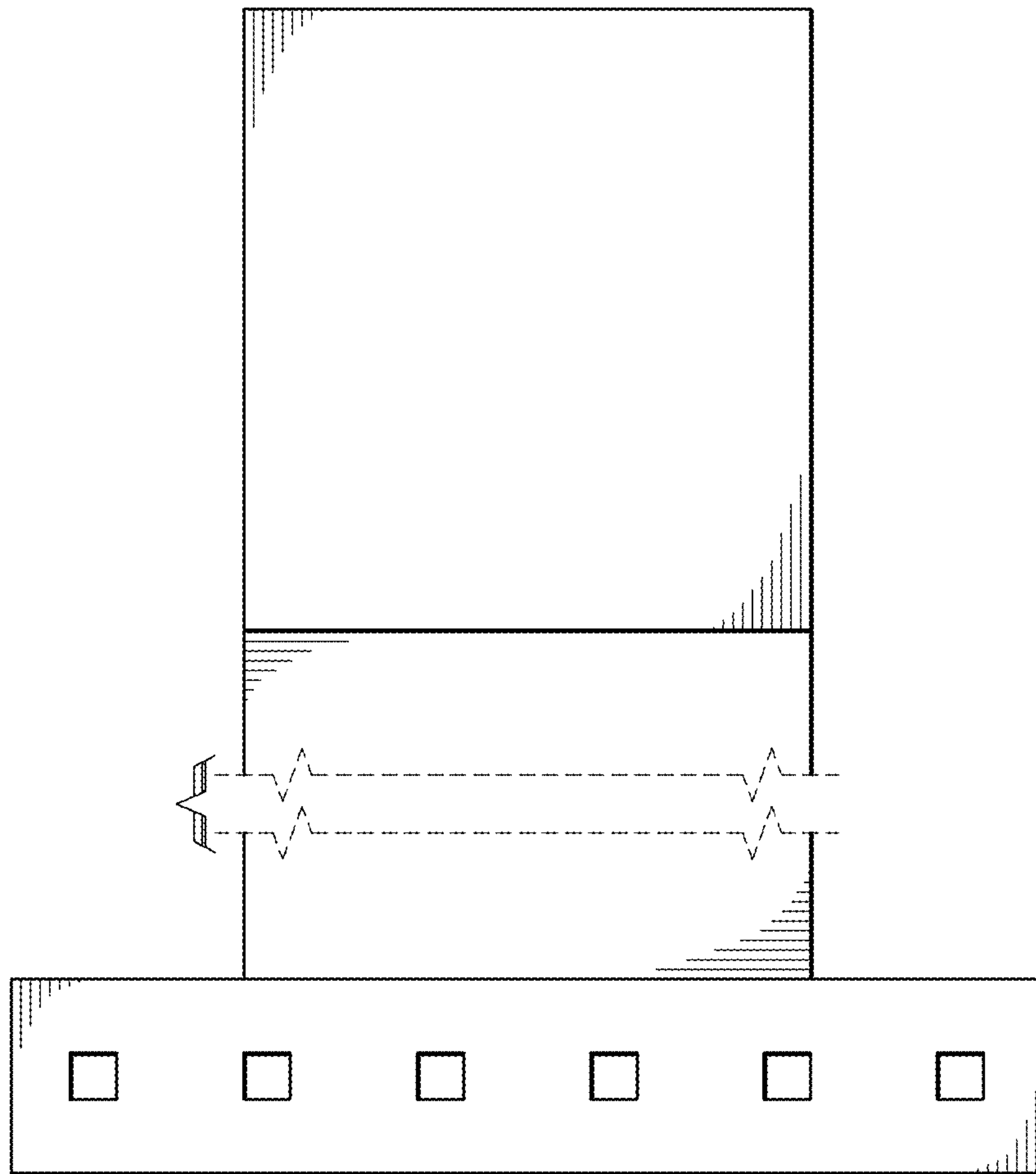

Fig. 29

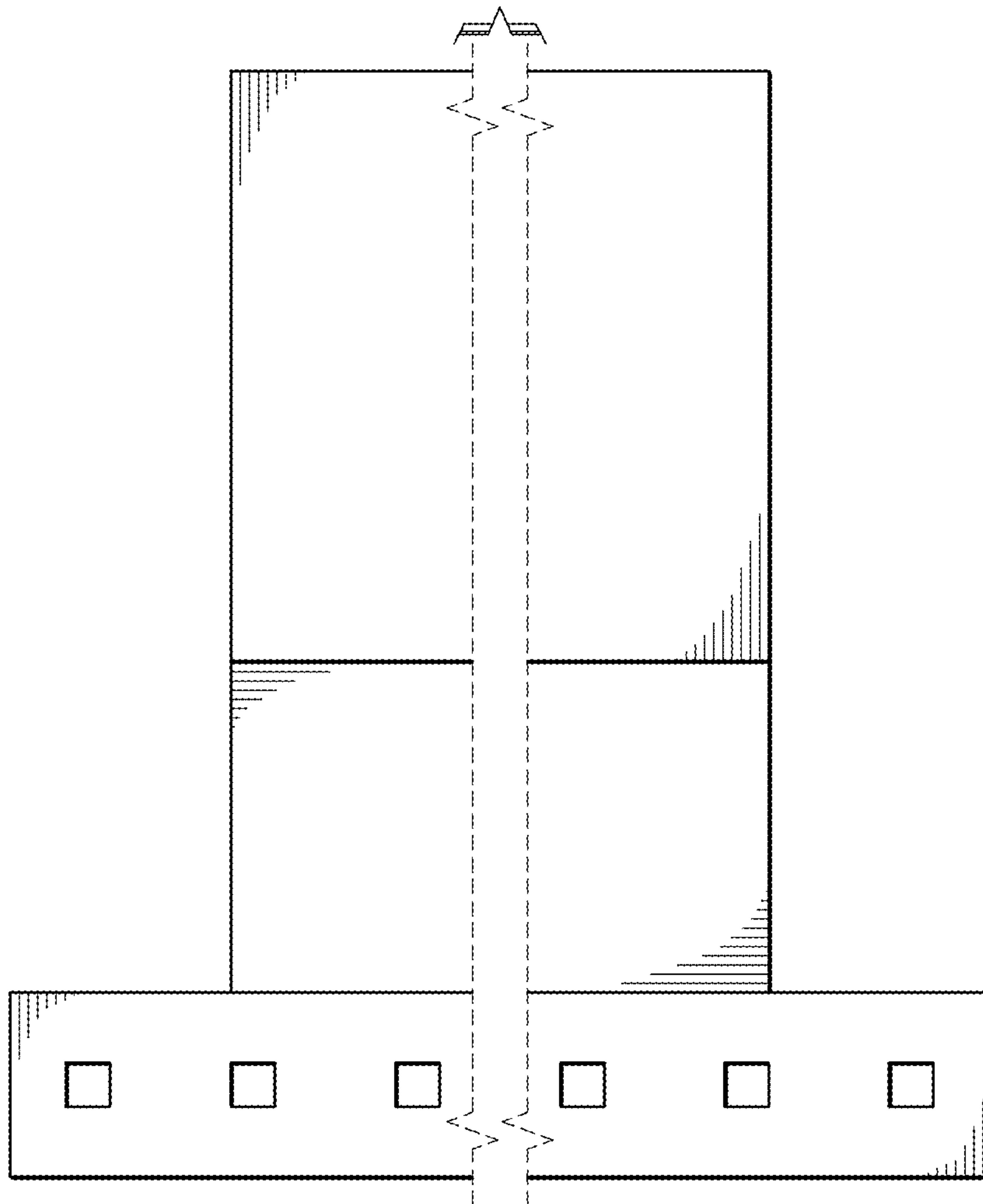

Fig. 30