



US00D827794S

(12) **United States Design Patent** (10) **Patent No.:** **US D827,794 S**  
**Licini** (45) **Date of Patent:** **\*\* Sep. 4, 2018**

- (54) **SHOWER WALL**
- (71) Applicant: **Kohler Co.**, Kohler, WI (US)
- (72) Inventor: **Frederic Licini**, L'Etang La Ville (FR)
- (73) Assignee: **KOHLER CO.**, Kohler, WI (US)
- (\*\*) Term: **15 Years**
- (21) Appl. No.: **29/639,198**
- (22) Filed: **Mar. 5, 2018**

D689,983 S 9/2013 Wilson  
 D787,017 S 5/2017 Tseng  
 9,677,256 B2 6/2017 Wilson

*Primary Examiner* — Robert A Delehanty  
 (74) *Attorney, Agent, or Firm* — Foley & Lardner LLP

(57) **CLAIM**

I claim the ornamental design for a shower wall, as shown and described.

**DESCRIPTION**

FIG. 1 is a perspective view of an embodiment of the claimed design including a shower wall, a showerhead, a hand shower and a controller;  
 FIG. 2 is a front view of the claimed design shown in FIG. 1;  
 FIG. 3 is a side view of the claimed design shown in FIG. 1;  
 FIG. 4 is another side view of the claimed design shown in FIG. 1;  
 FIG. 5 is a top view of the claimed design shown in FIG. 1;  
 FIG. 6 is a bottom view of the claimed design shown in FIG. 1; and,  
 FIG. 7 is a rear view of the claimed design shown in FIG. 1.

The ornamental design that is claimed is shown in the drawings as solid lines and surfaces having surface shading. The broken lines in the drawings are for illustrative purposes only and form no part of the claimed design. For example, broken lines formed by equal length dashes show unclaimed portions of the design. Broken lines formed of unequal length dashes (i.e., dash-dot) show boundaries between either claimed and unclaimed portions of the design or between unclaimed and unclaimed portions of the design.

**1 Claim, 5 Drawing Sheets**

**Related U.S. Application Data**

- (62) Division of application No. 29/565,189, filed on May 18, 2016, now Pat. No. Des. 823,447.
- (51) **LOC (11) Cl.** ..... **23-01**
- (52) **U.S. Cl.**  
USPC ..... **D23/304**
- (58) **Field of Classification Search**  
USPC ..... D23/228, 303–305, 283, 249–250, 252, D23/254; D8/300, 307–308, 310  
CPC ..... Y10T 137/9464  
See application file for complete search history.

**References Cited**

**U.S. PATENT DOCUMENTS**

- 3,737,107 A 6/1973 Wright
- 4,048,767 A 9/1977 Ferich
- 5,303,519 A 4/1994 Mustee
- D541,394 S 4/2007 Toyohara
- D598,522 S 8/2009 Schoenherr
- D648,825 S 11/2011 Ando

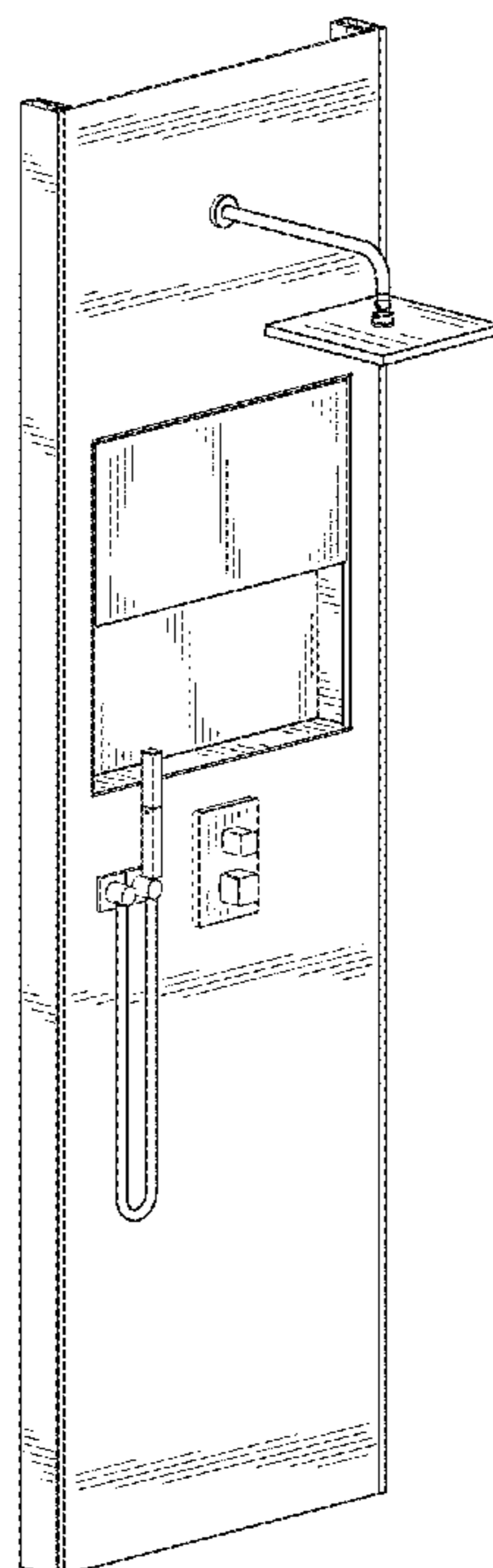

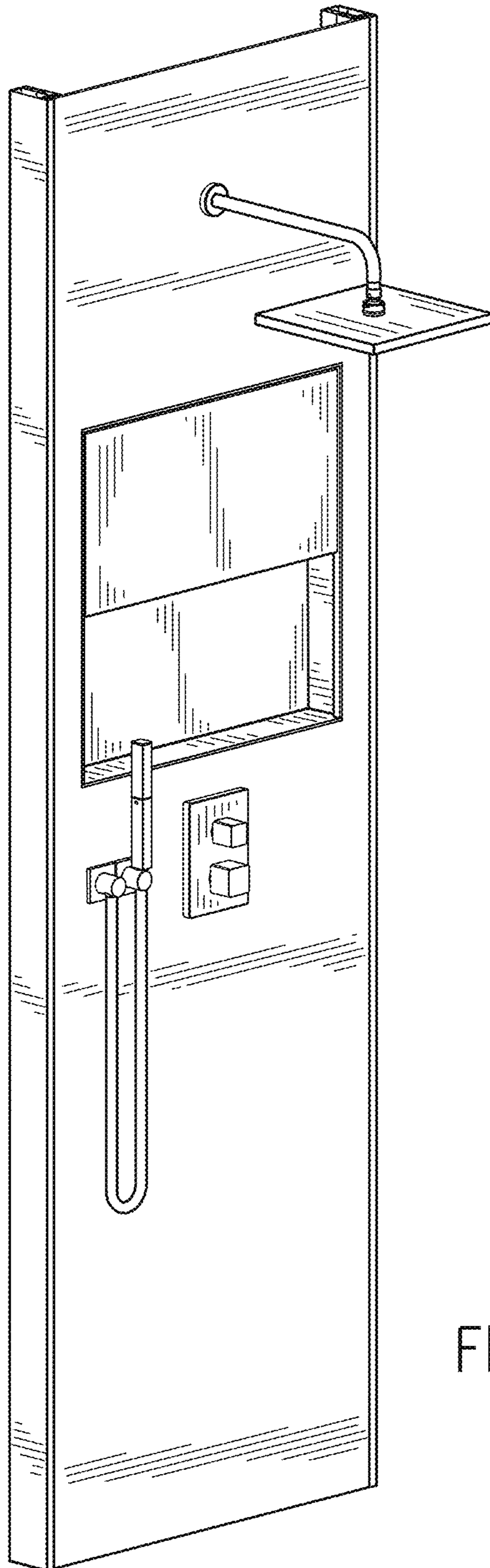

FIG. 1

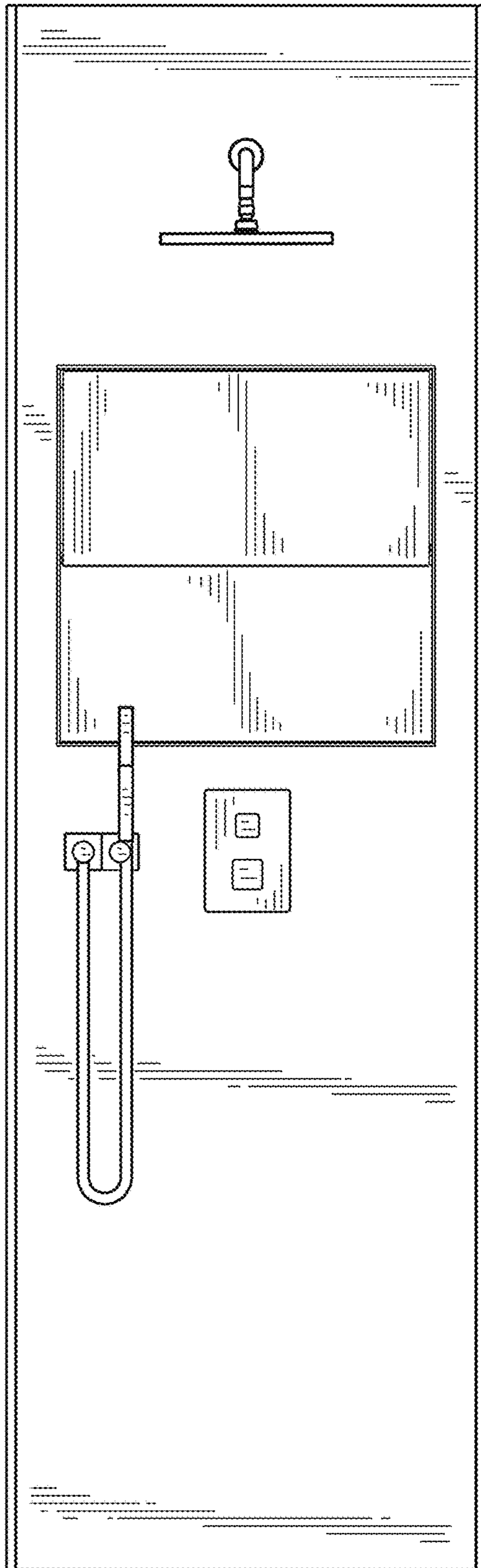

FIG. 2

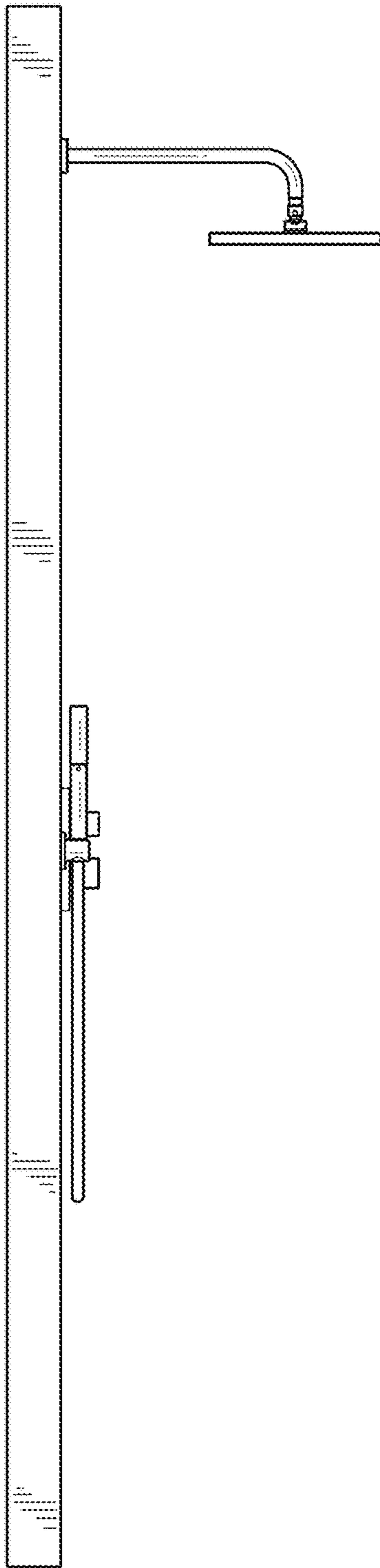

FIG. 3

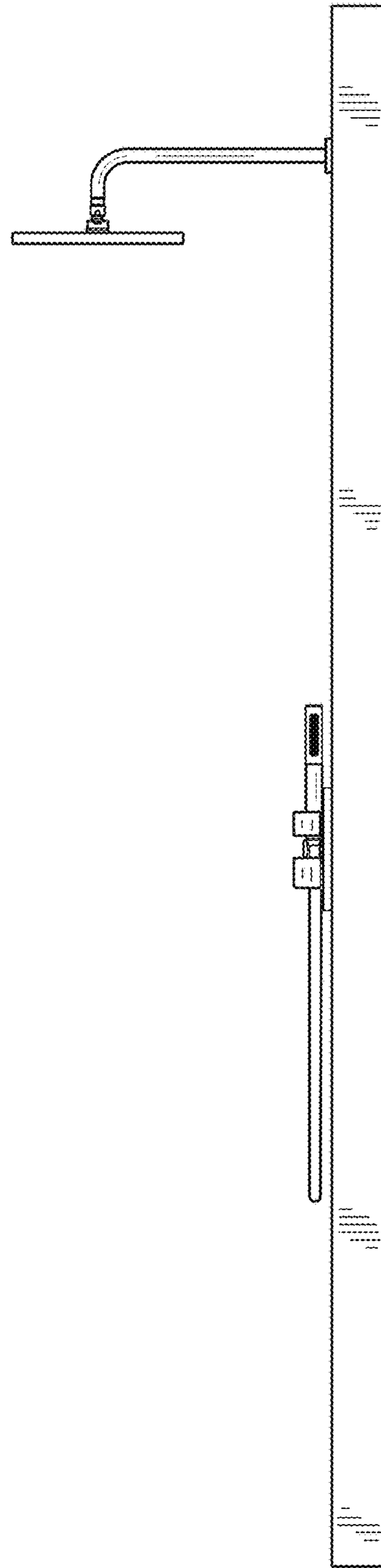

FIG. 4

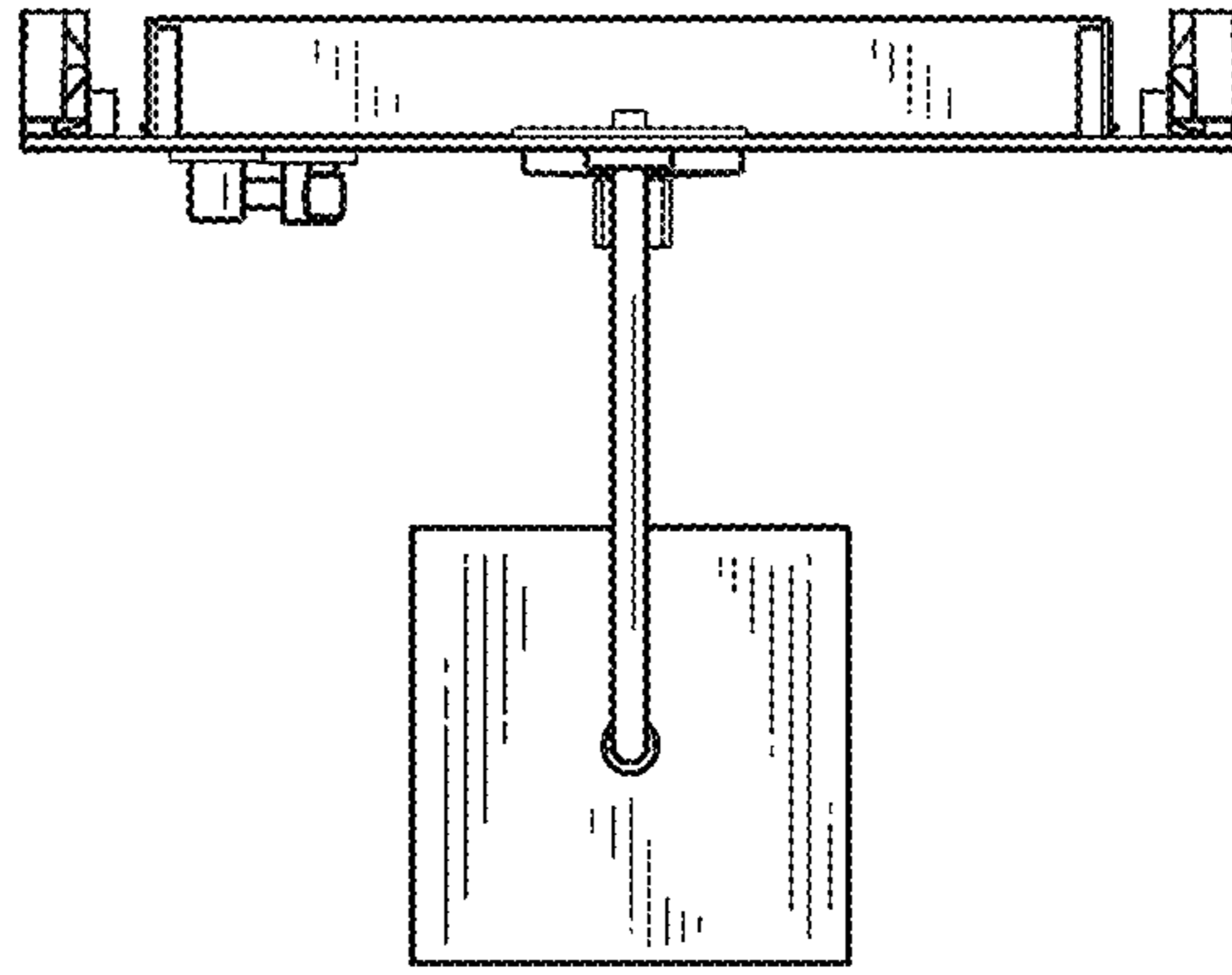

FIG. 5

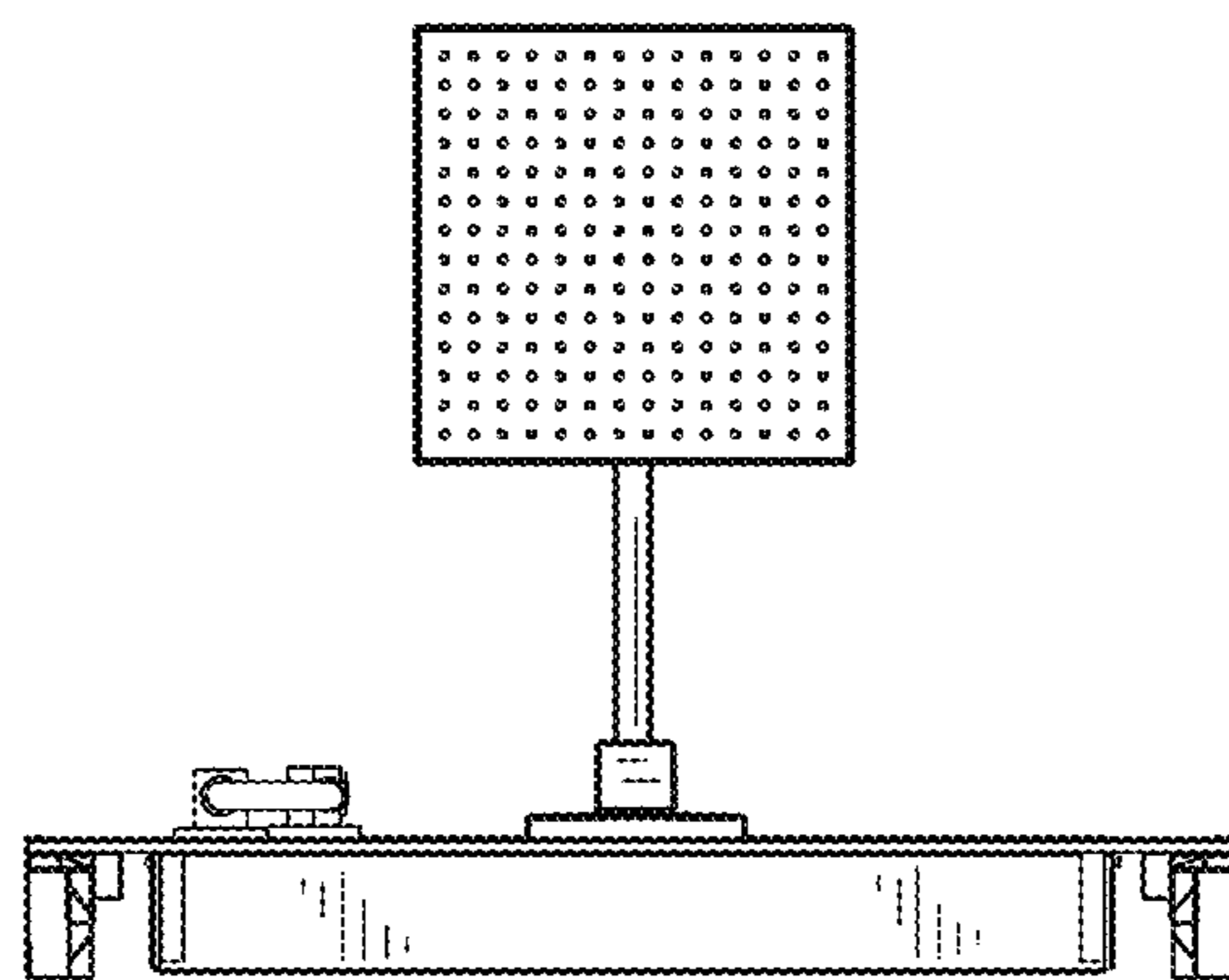

FIG. 6



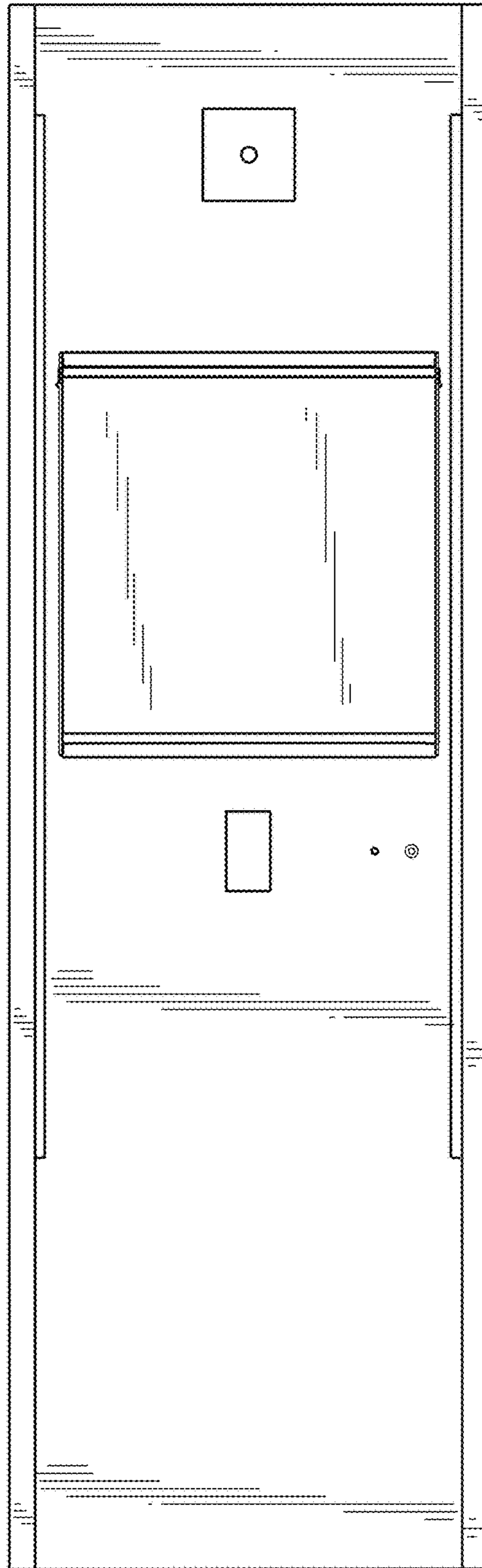

FIG. 7