



US00D827500S

(12) **United States Design Patent**
Lovold et al.

(10) **Patent No.:** **US D827,500 S**
(45) **Date of Patent:** **** Sep. 4, 2018**

(54) **ALL-TERRAIN VEHICLE**

(71) Applicant: **Polaris Industries Inc.**, Medina, MN (US)

(72) Inventors: **Ryan K. Lovold**, Roseau, MN (US);
Cameron Fisher, Plymouth, MN (US);
Heather L. VanSlyke, Zimmerman, MN (US);
Thomas C. Hanegraaf, Elk River, MN (US)

(73) Assignee: **Polaris Industries Inc.**, Medina, MN (US)

(**) Term: **15 Years**

(21) Appl. No.: **29/570,498**

(22) Filed: **Jul. 8, 2016**

(51) **LOC (11) Cl.** **12-11**

(52) **U.S. Cl.**
USPC **D12/107**

(58) **Field of Classification Search**
USPC D12/3, 4, 5, 14, 85, 86, 87, 107, 110
CPC .. A01B 59/02; A61G 3/08; B62B 5/04; B62B 13/10; B62B 19/04; B62B 2202/404; B62C 9/00; B62D 7/22; B62K 5/01; B60K 23/0808

See application file for complete search history.

(56) **References Cited**

U.S. PATENT DOCUMENTS

D374,416 S	*	10/1996	Miyamoto	D12/107
D513,718 S	*	1/2006	Itaya	D12/107
D520,914 S	*	5/2006	Luh	D12/107
D522,924 S	*	6/2006	Yokoyama	D12/107
D539,705 S	*	4/2007	Ichikawa	D12/107
D546,246 S	*	7/2007	Crepeau	D12/107

(Continued)

Primary Examiner — Darlington Ly

(74) *Attorney, Agent, or Firm* — Faegre Baker Daniels LLP

(57) **CLAIM**

The ornamental design for an all-terrain vehicle, as shown and described.

DESCRIPTION

FIG. 1 is a top, front, and left side perspective view of an all-terrain vehicle showing our new design;
 FIG. 2 is a top, rear, and right side perspective view thereof;
 FIG. 3 is a left side elevation view thereof;
 FIG. 4 is a right side elevation view thereof;
 FIG. 5 is a top plan view thereof;
 FIG. 6 is a front elevation view thereof;
 FIG. 7 is a rear elevation view thereof;
 FIG. 8 is a top, front, and left side perspective view of an all-terrain vehicle showing our new design in accordance to a second embodiment, of which includes an additional set of rack extenders on the front rack;
 FIG. 9 is a top, rear, and right side perspective view thereof;
 FIG. 10 is a left side elevation view thereof;
 FIG. 11 is a right side elevation view thereof;
 FIG. 12 is a top plan view thereof;
 FIG. 13 is a front elevation view thereof;
 FIG. 14 is a rear elevation view thereof;
 FIG. 15 is a top, rear, and right side perspective view of an all-terrain vehicle showing our new design in accordance to a third embodiment, of which includes an additional set of rack extenders on the front rack;
 FIG. 16 is a top, front, and left side perspective view thereof;
 FIG. 17 is a left side elevation view thereof;
 FIG. 18 is a right side elevation view thereof;
 FIG. 19 is a top plan view thereof;
 FIG. 20 is a front elevation view thereof; and,
 FIG. 21 is a rear elevation view thereof.

The broken lines in the drawings illustrate portions of the all-terrain vehicle that form no part of the claimed design.

1 Claim, 21 Drawing Sheets

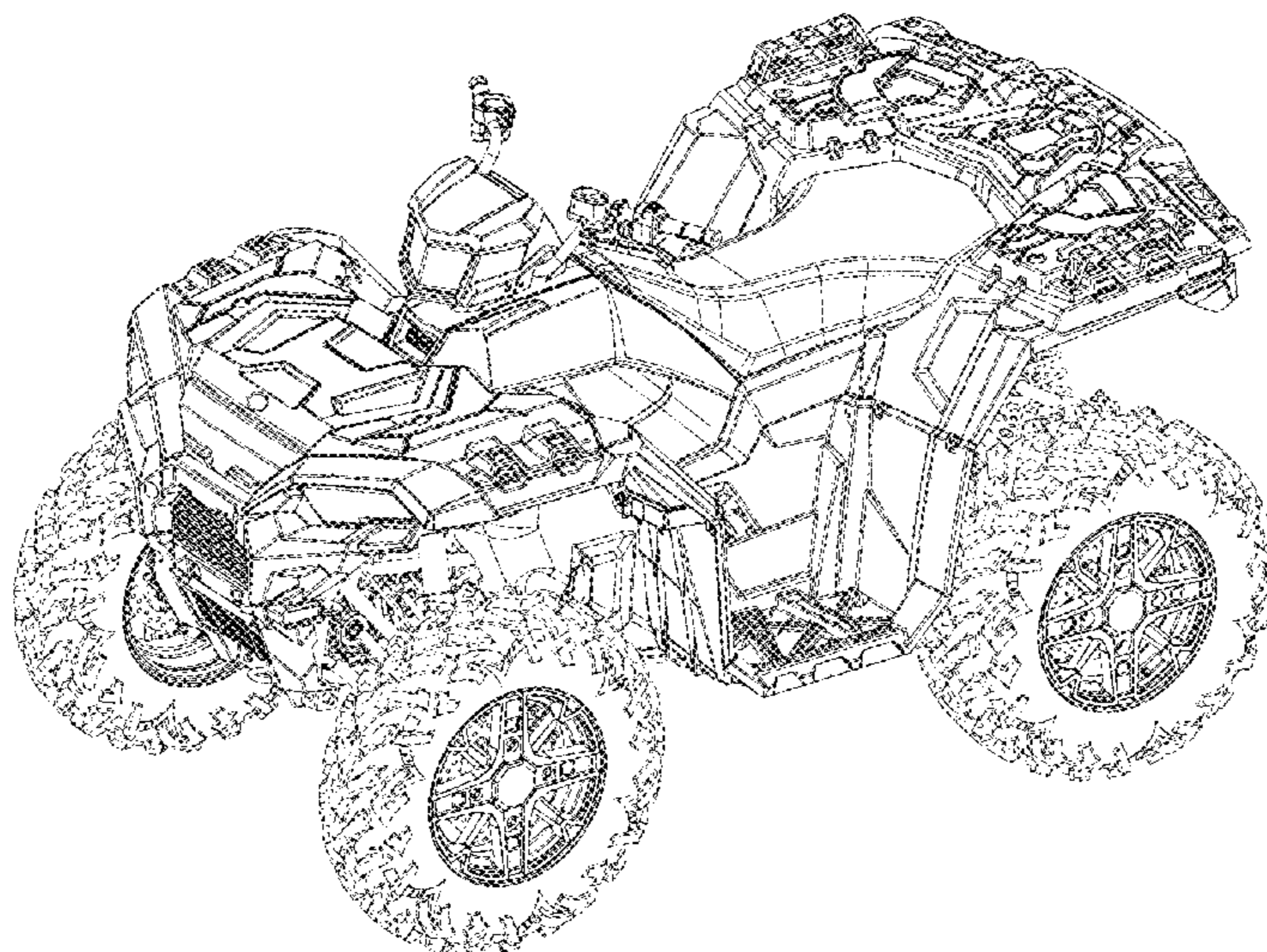

(56)

References Cited

U.S. PATENT DOCUMENTS

D585,792 S *	2/2009	Chao	D12/107
7,743,864 B2 *	6/2010	Tweet	B60N 2/24
			180/312
D620,399 S *	7/2010	Wu	D12/107
D628,520 S *	12/2010	Lin	D12/107
D643,781 S *	8/2011	Nagao	D12/107
D680,468 S *	4/2013	Li	D12/107
2008/0277184 A1 *	11/2008	Marleau	B62K 5/01
			180/312

* cited by examiner

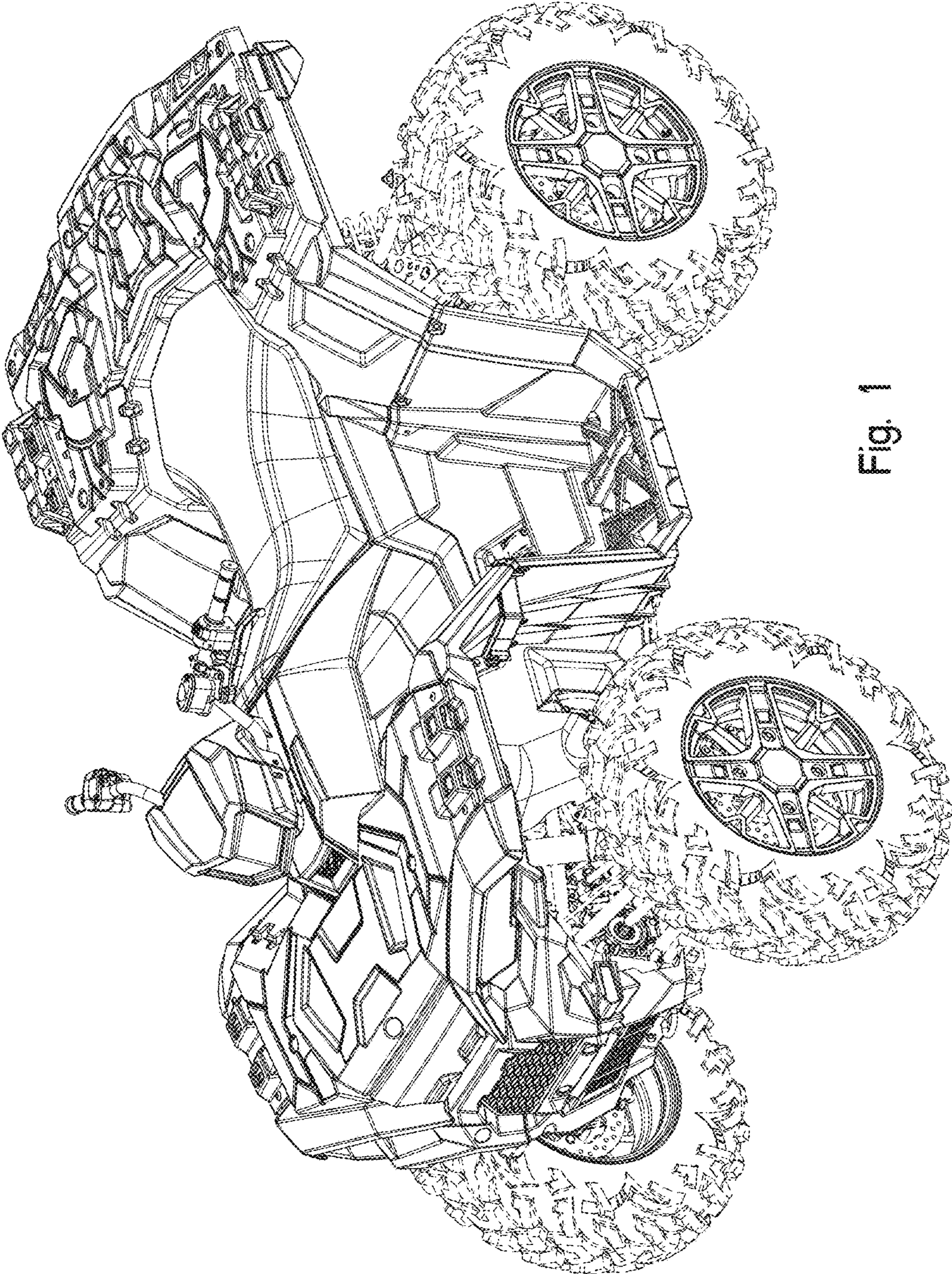

Fig. 1

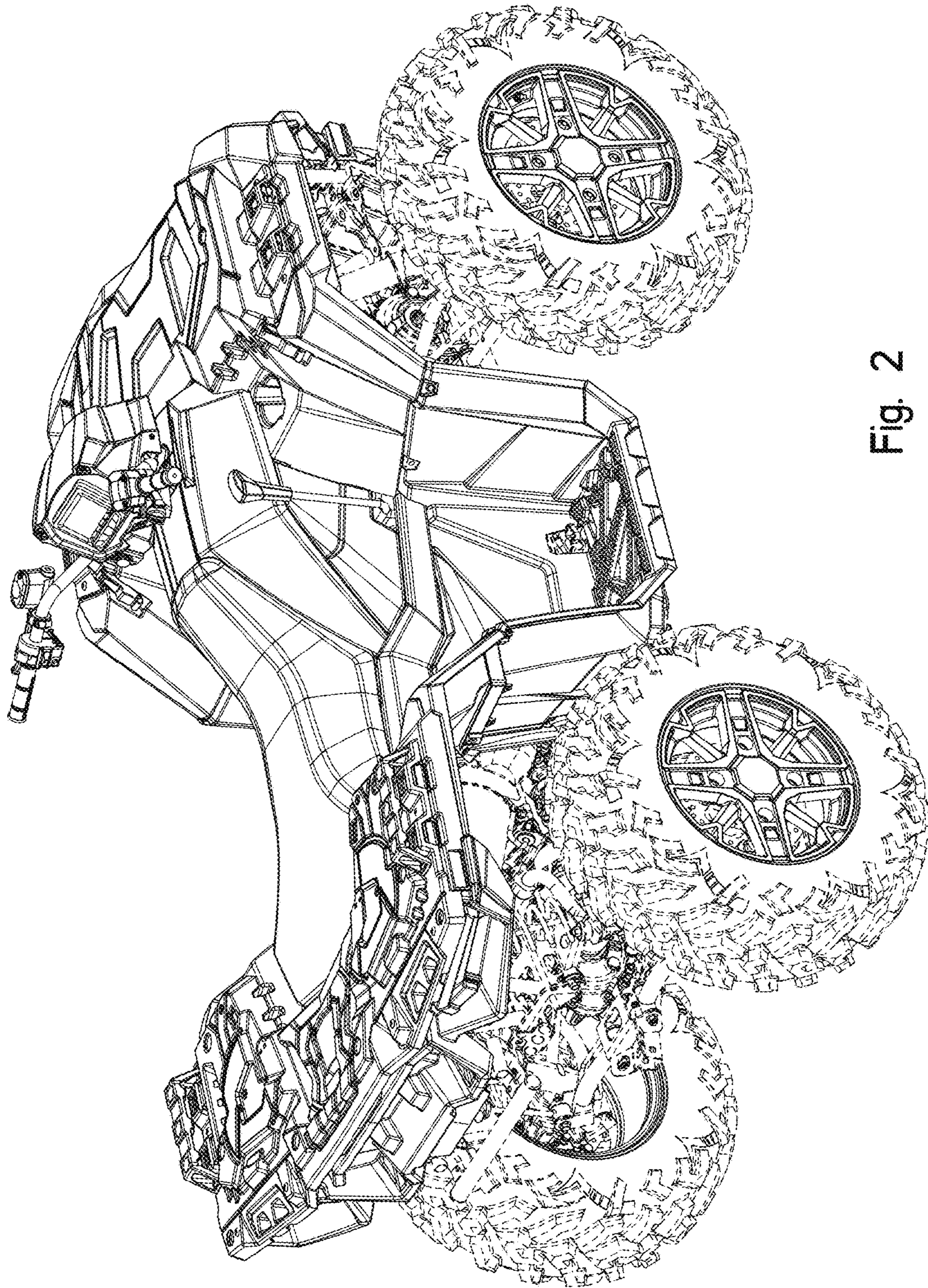

Fig. 2

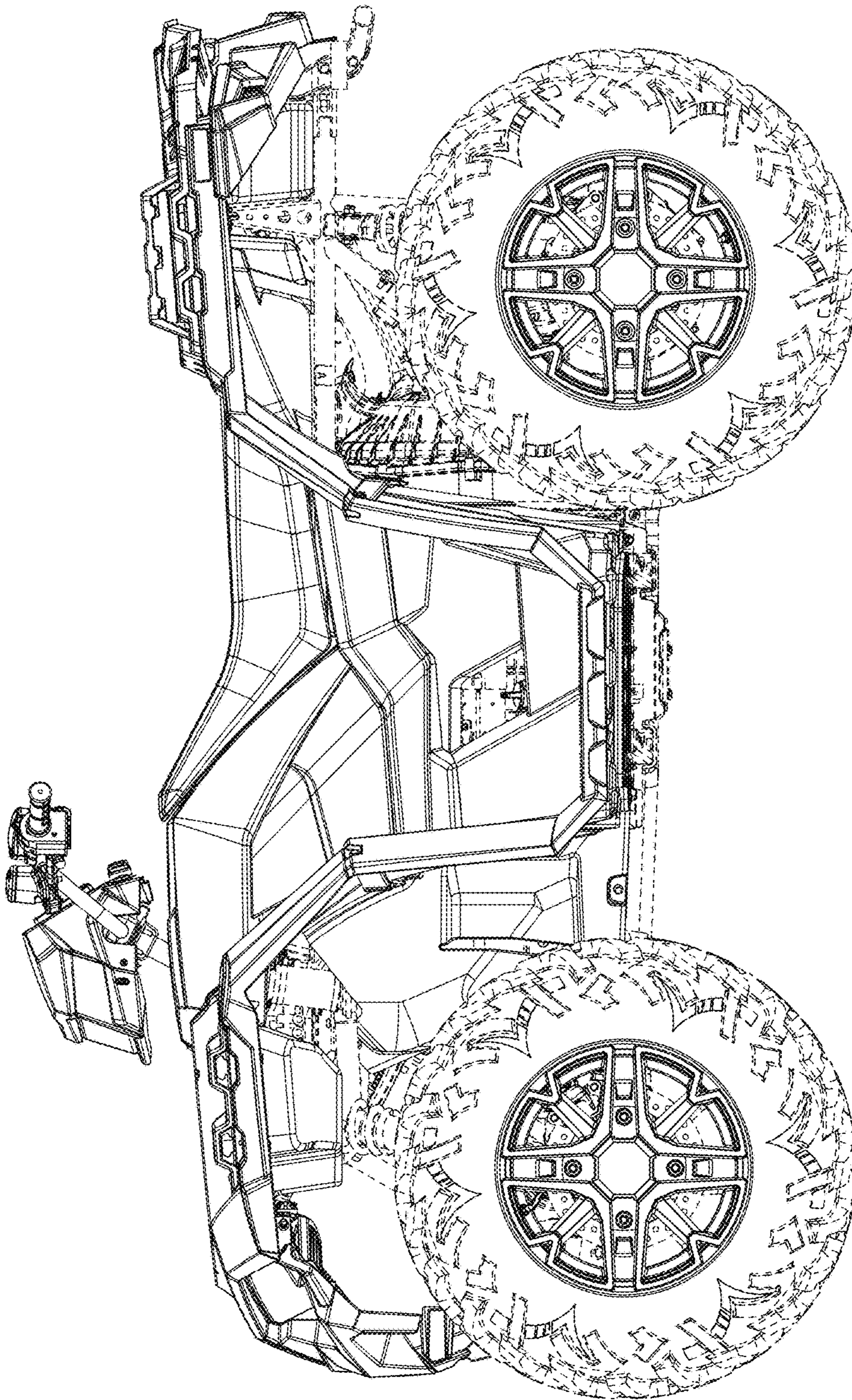

Fig. 3

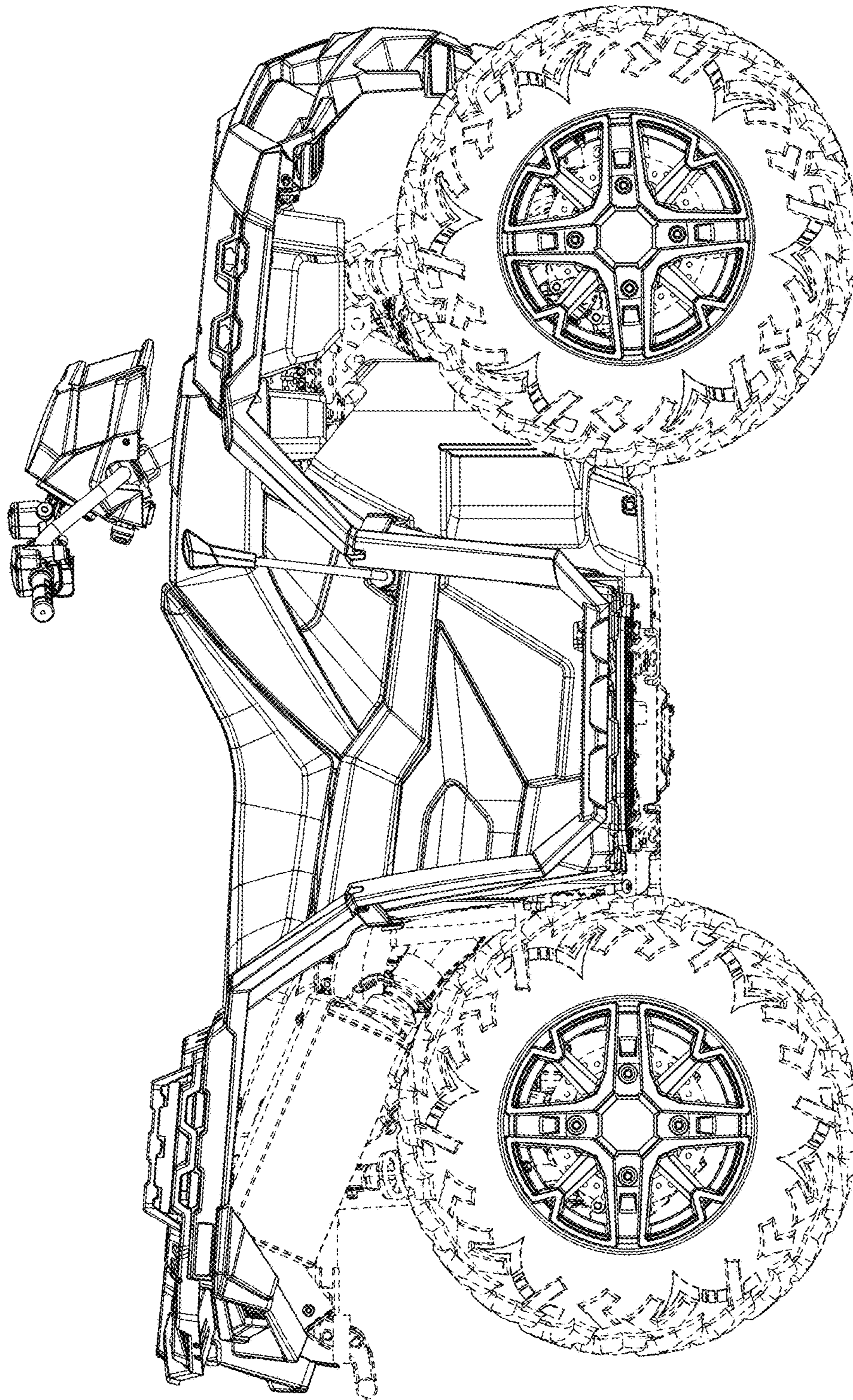

Fig. 4

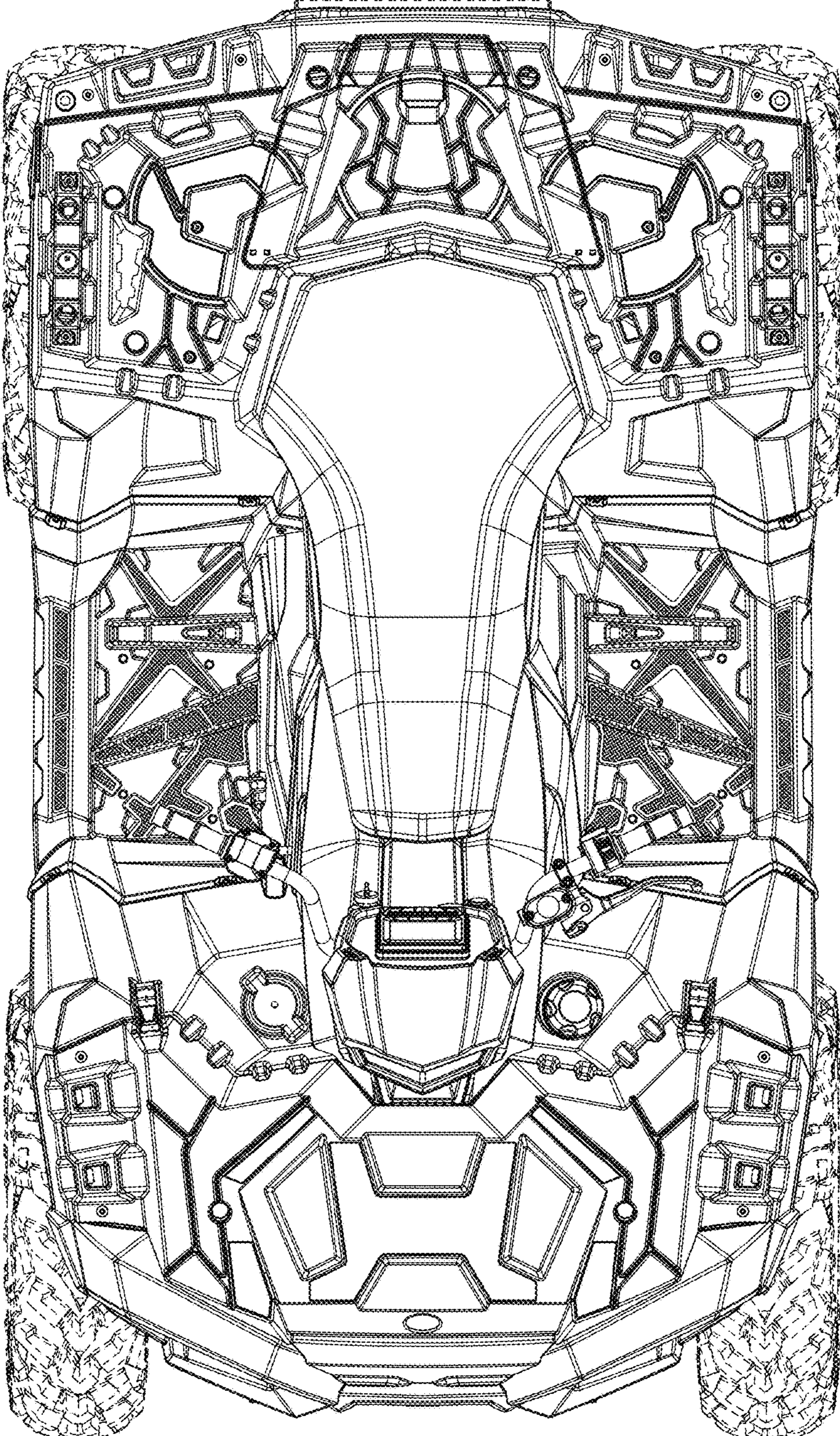

Fig. 5

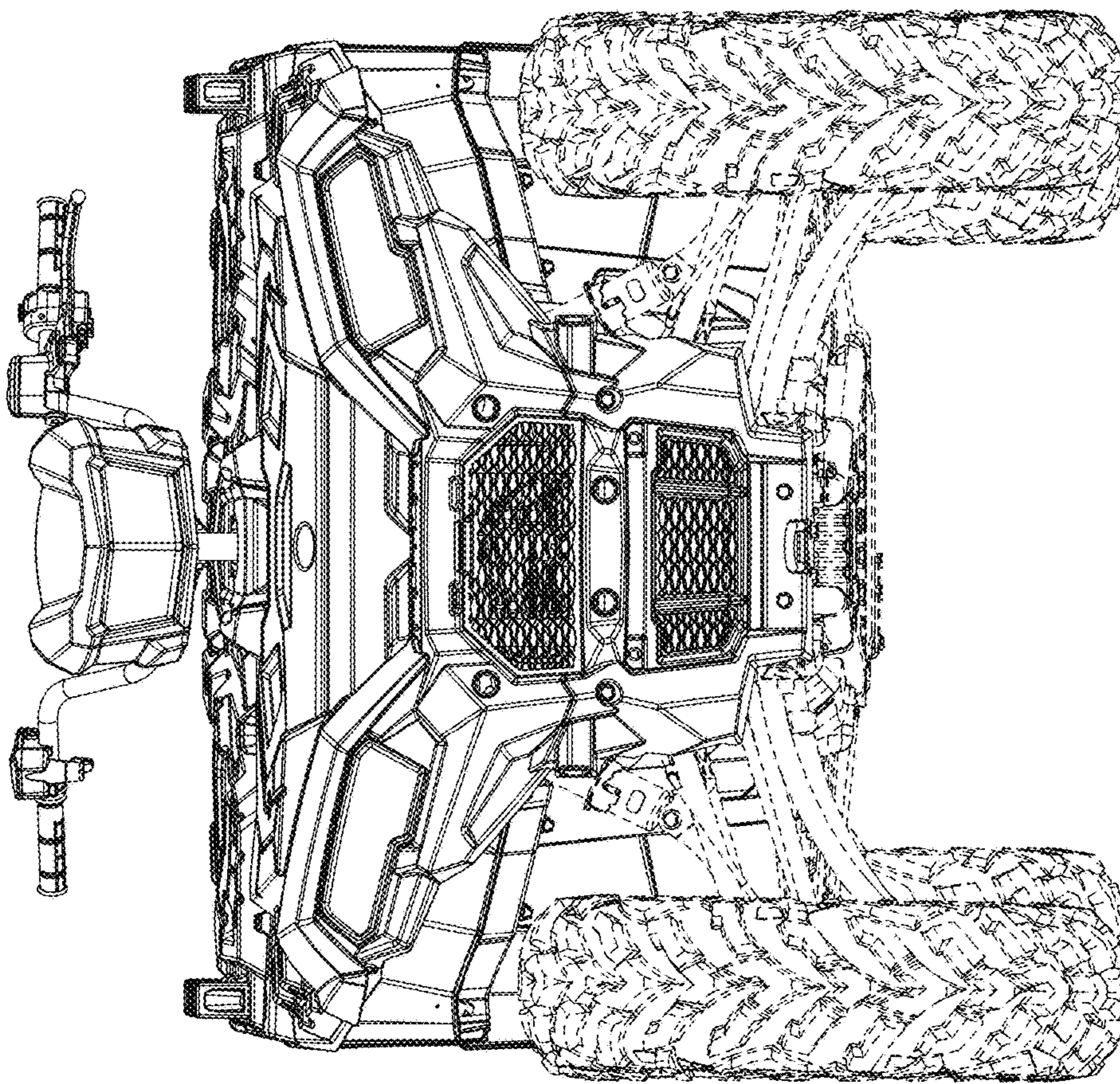

Fig. 6

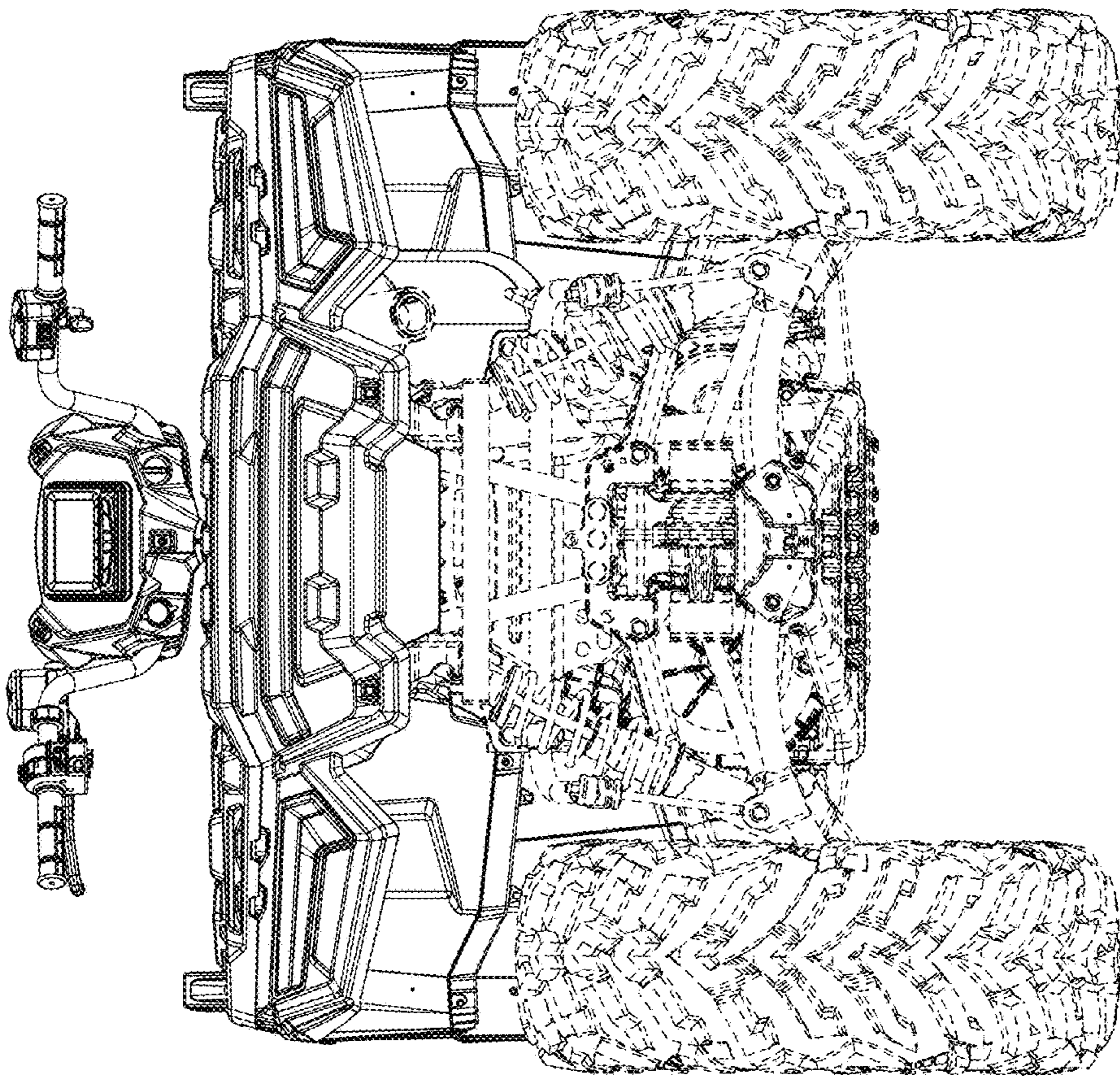

Fig. 7

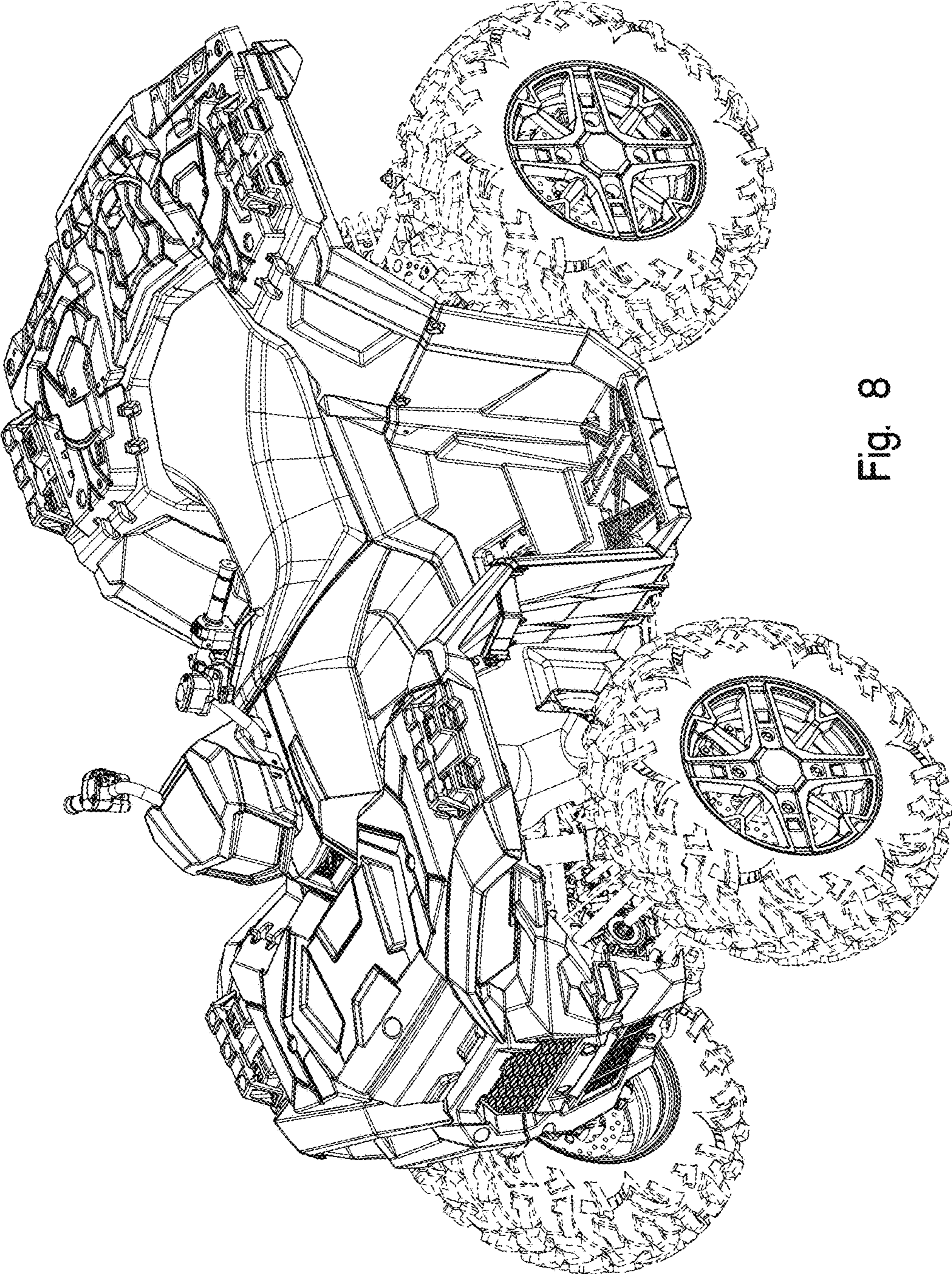

Fig. 8

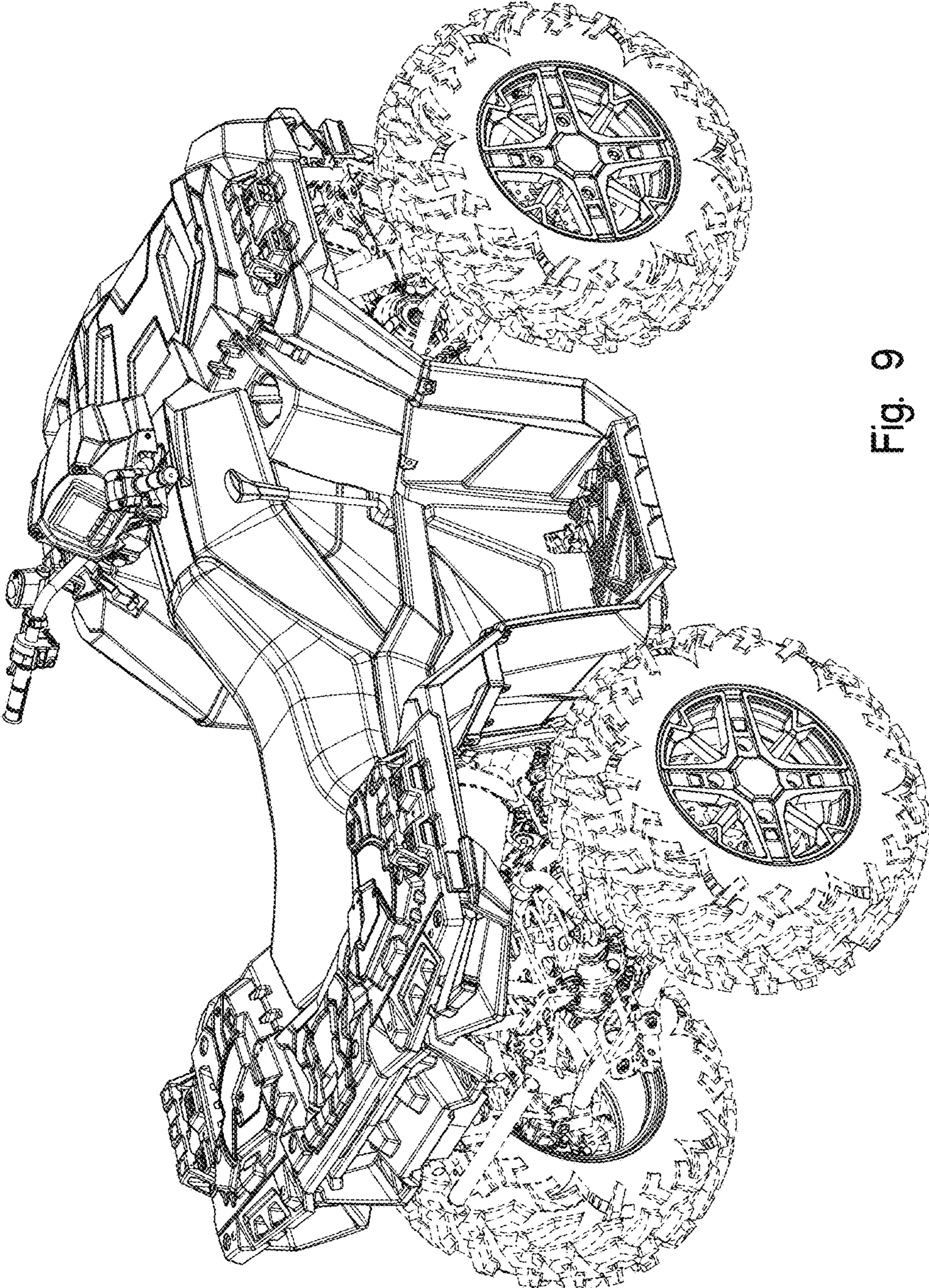

Fig. 9

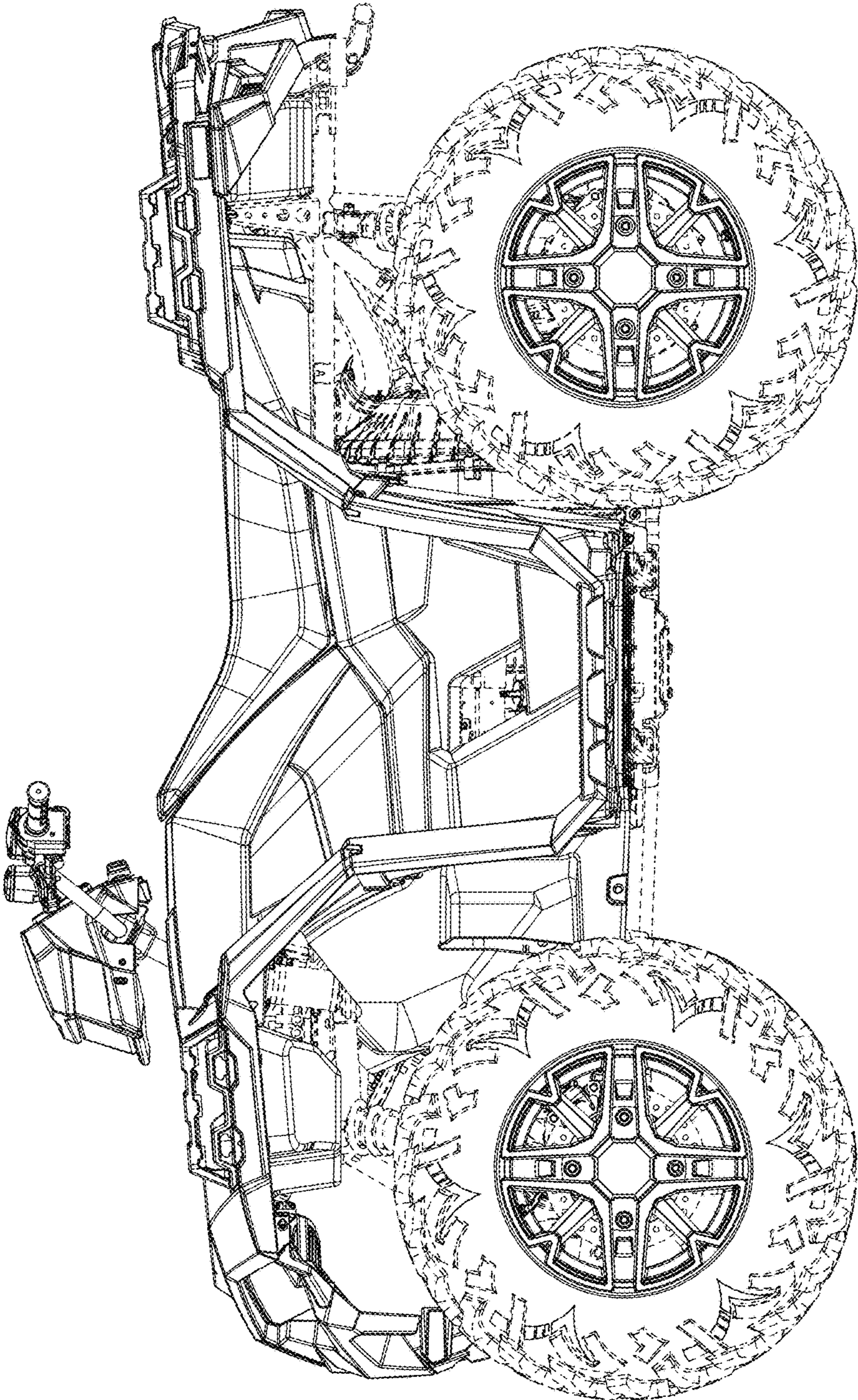

Fig. 10

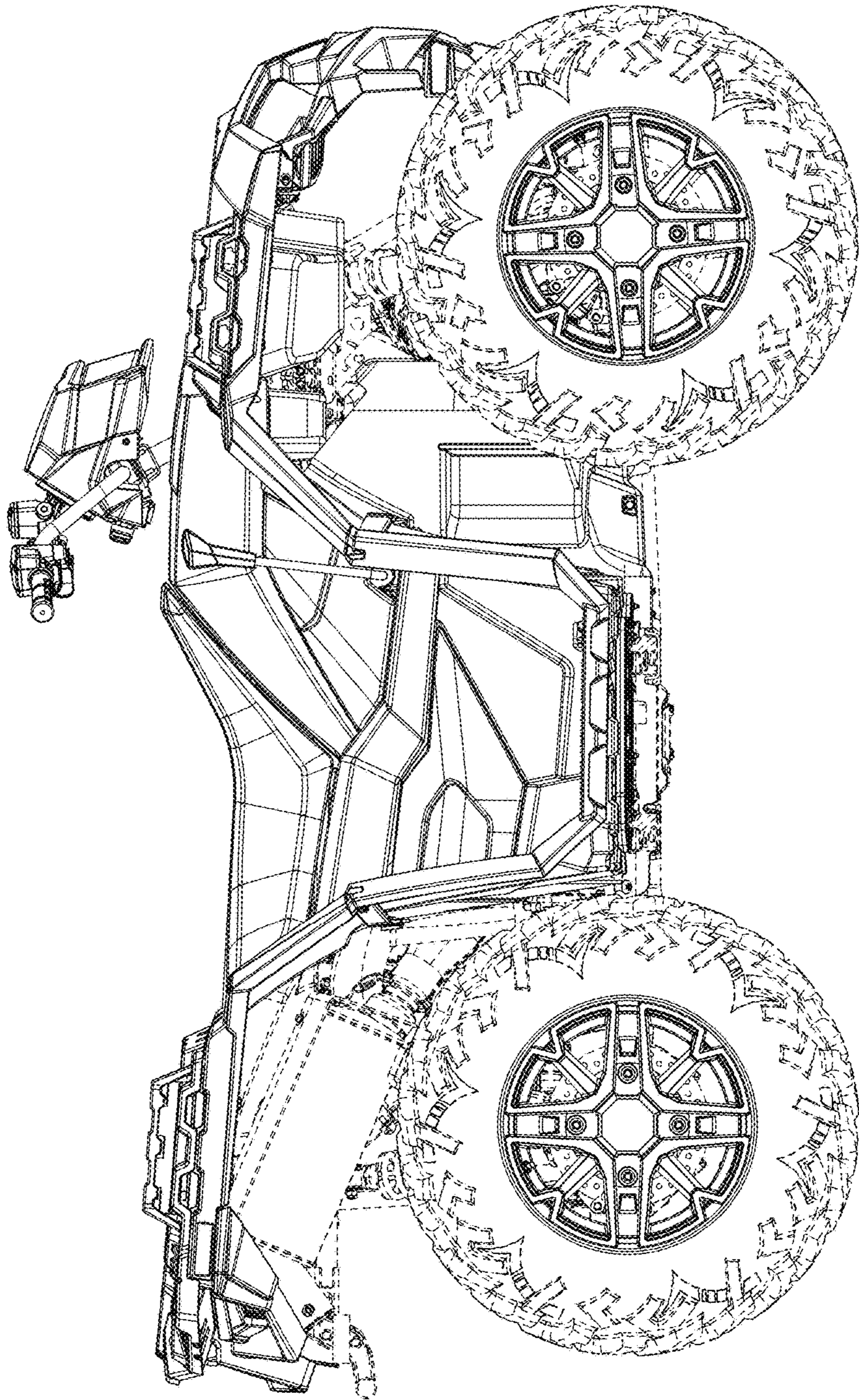

Fig. 11

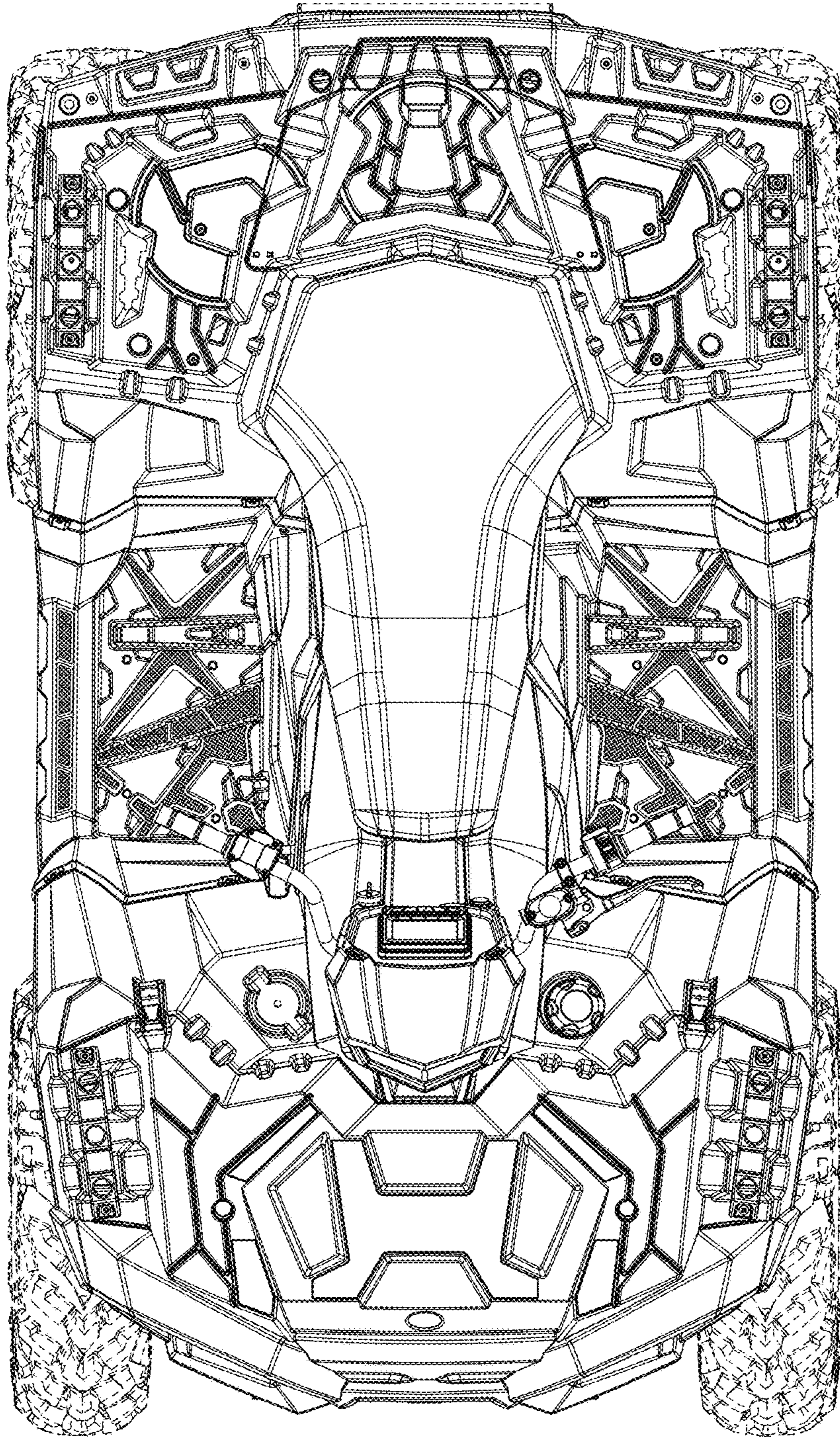

Fig. 12

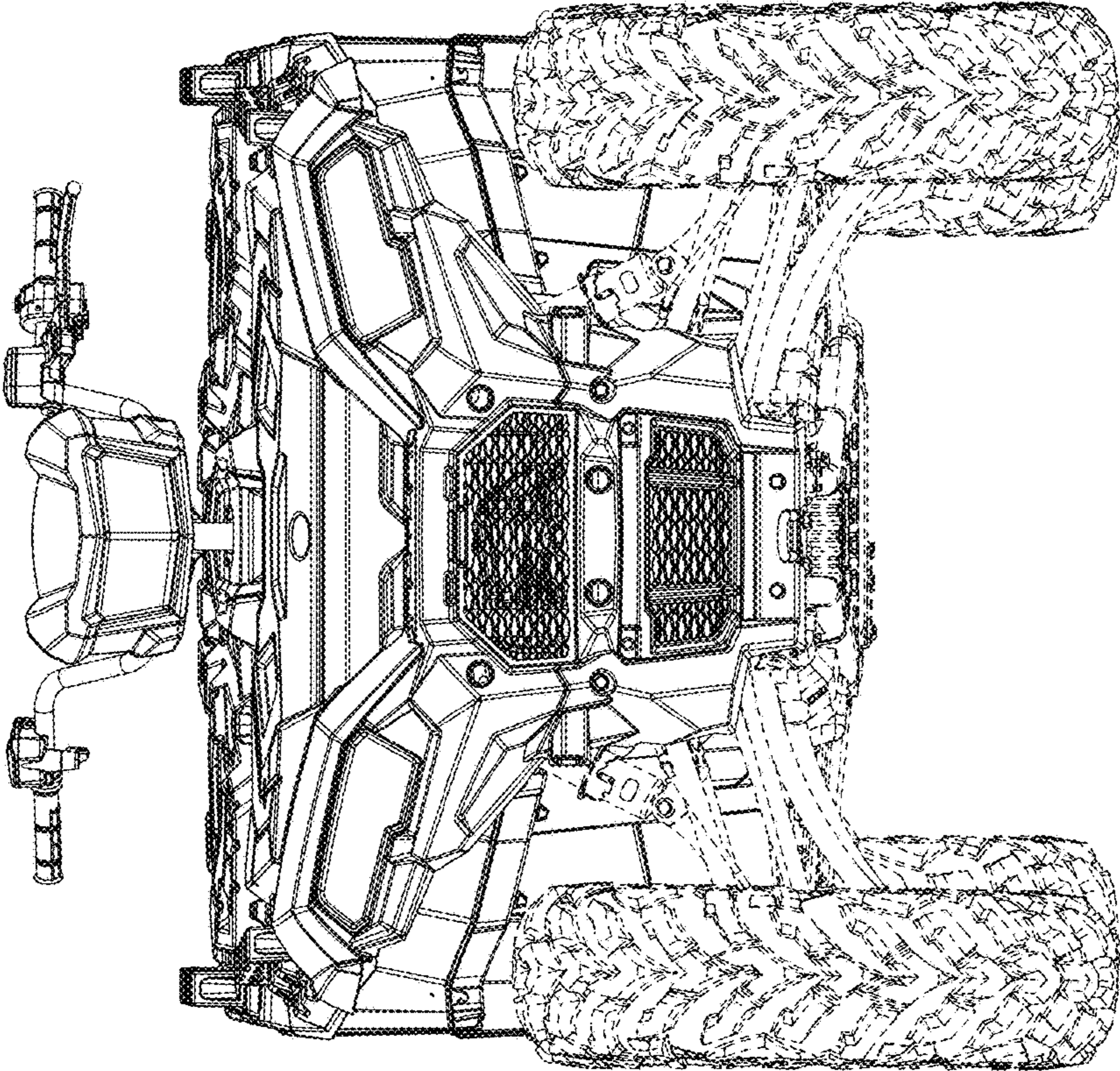

Fig. 13

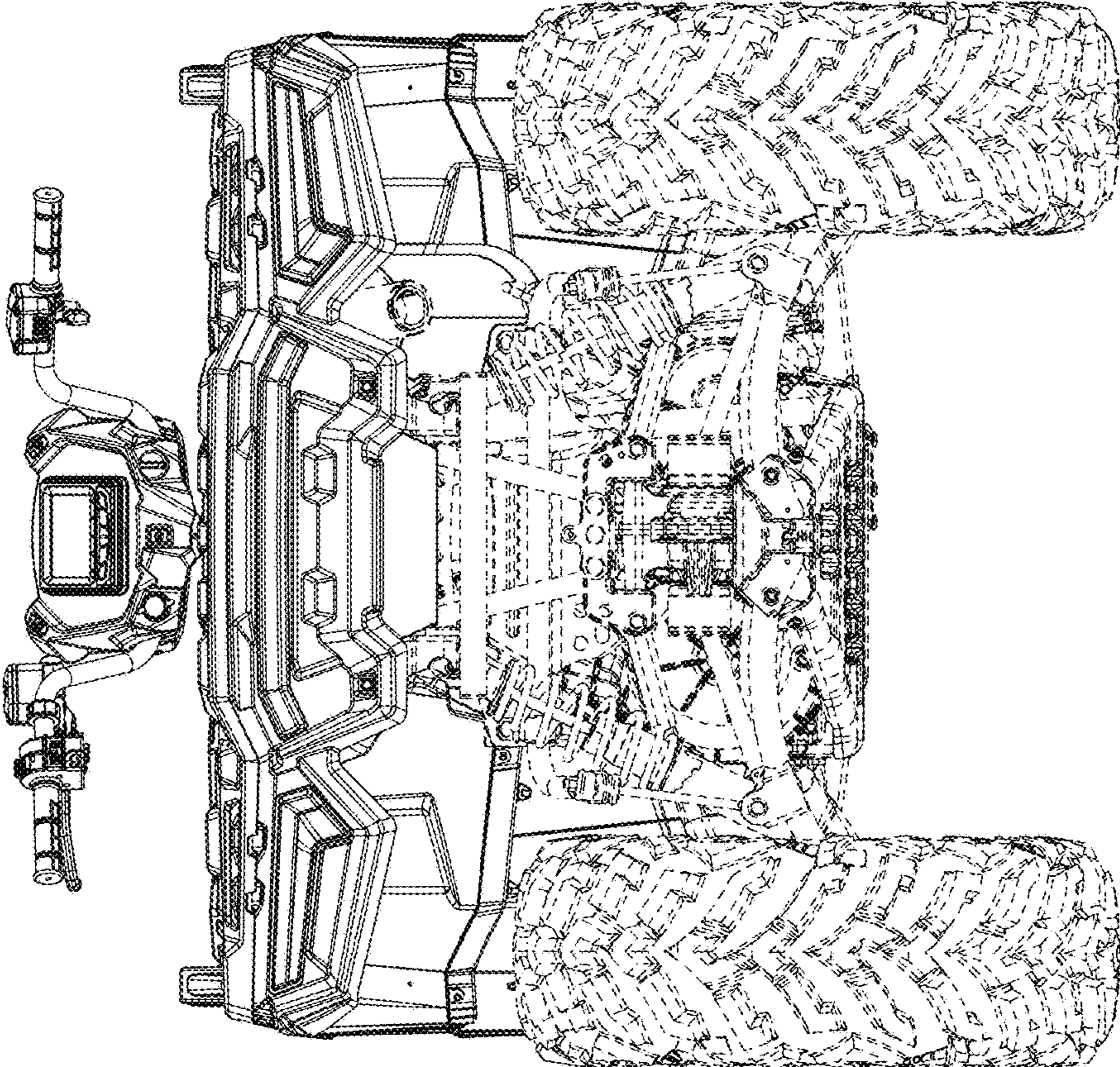

Fig. 14

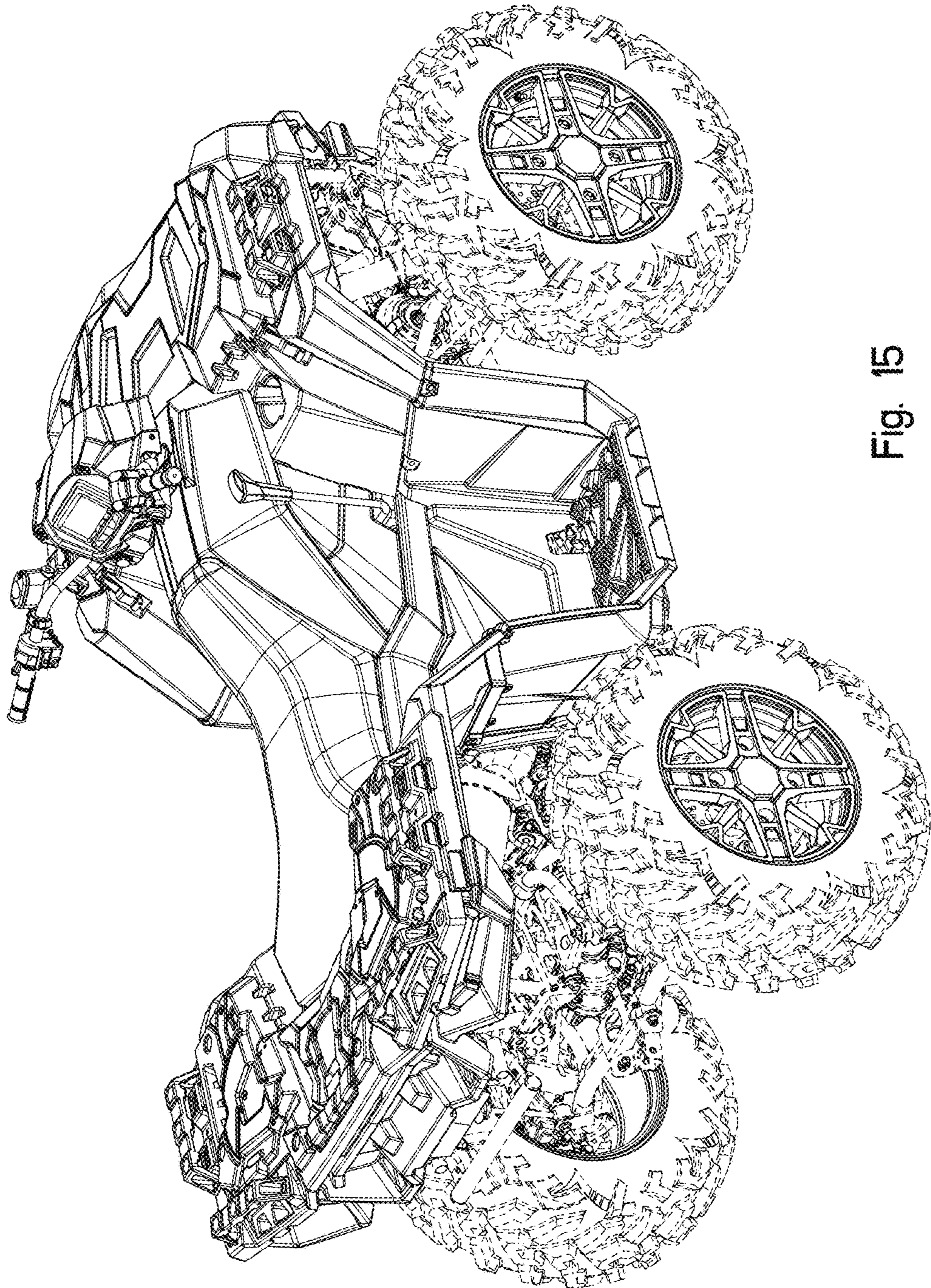

Fig. 15

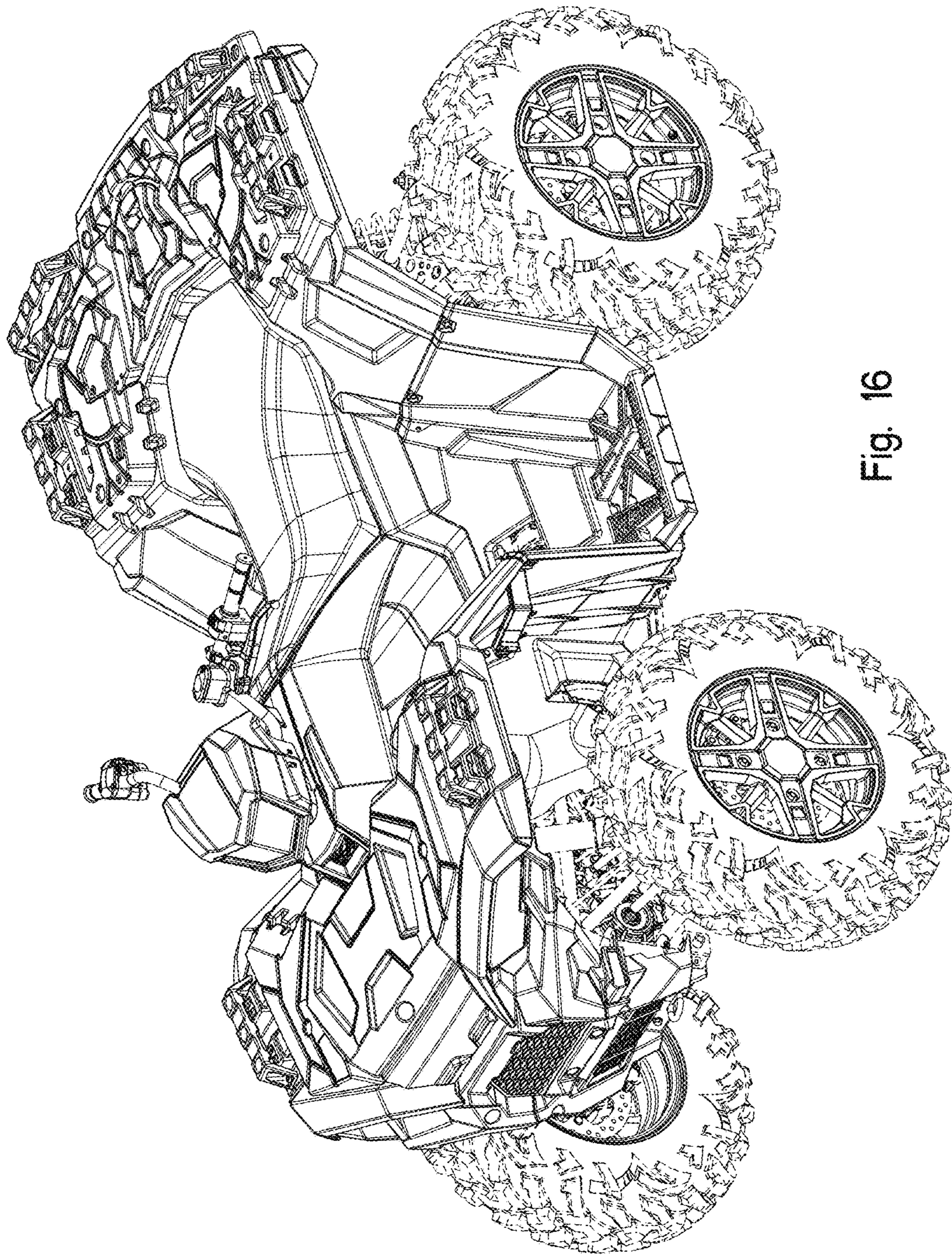

Fig. 16

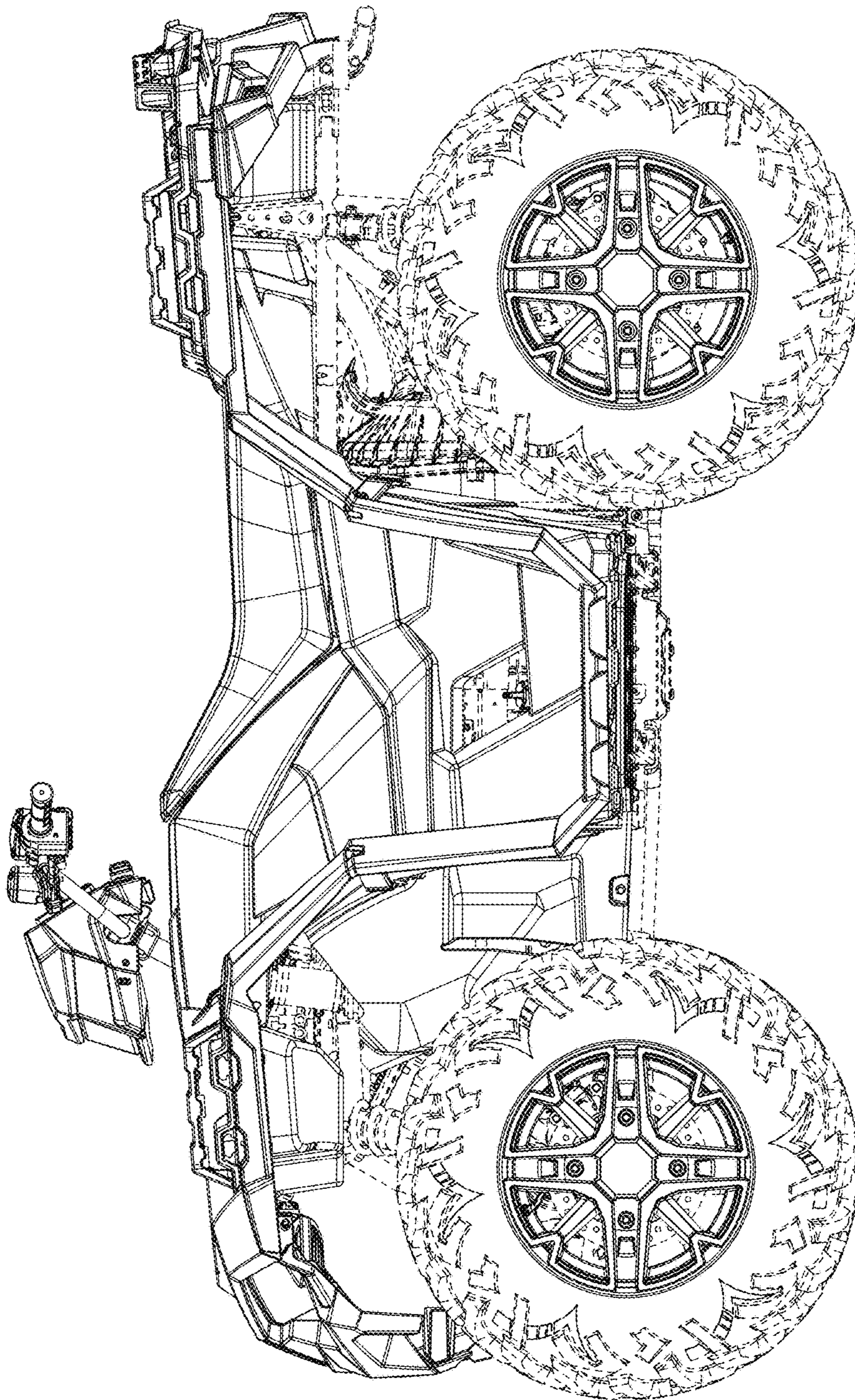

Fig. 17

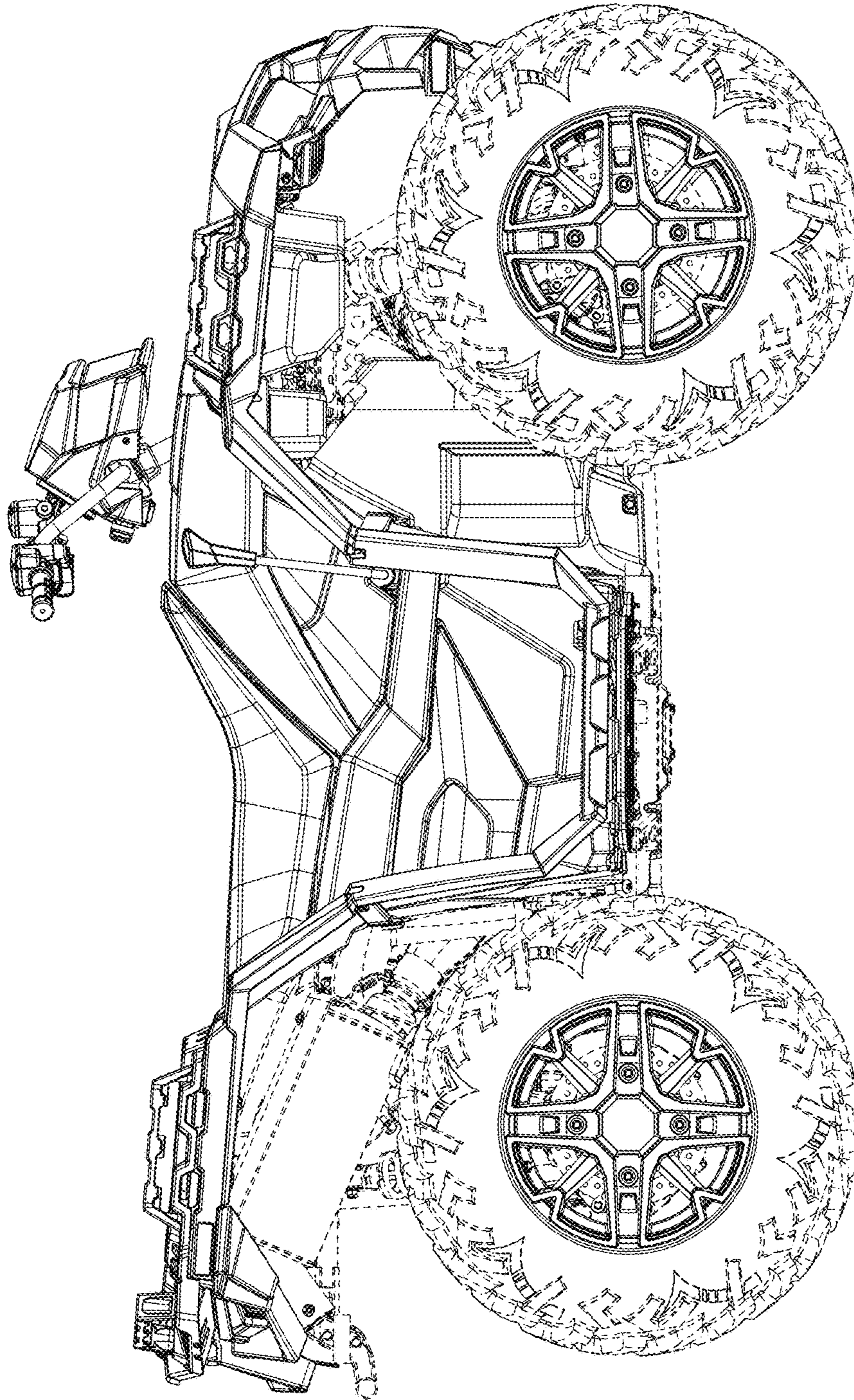

Fig. 18

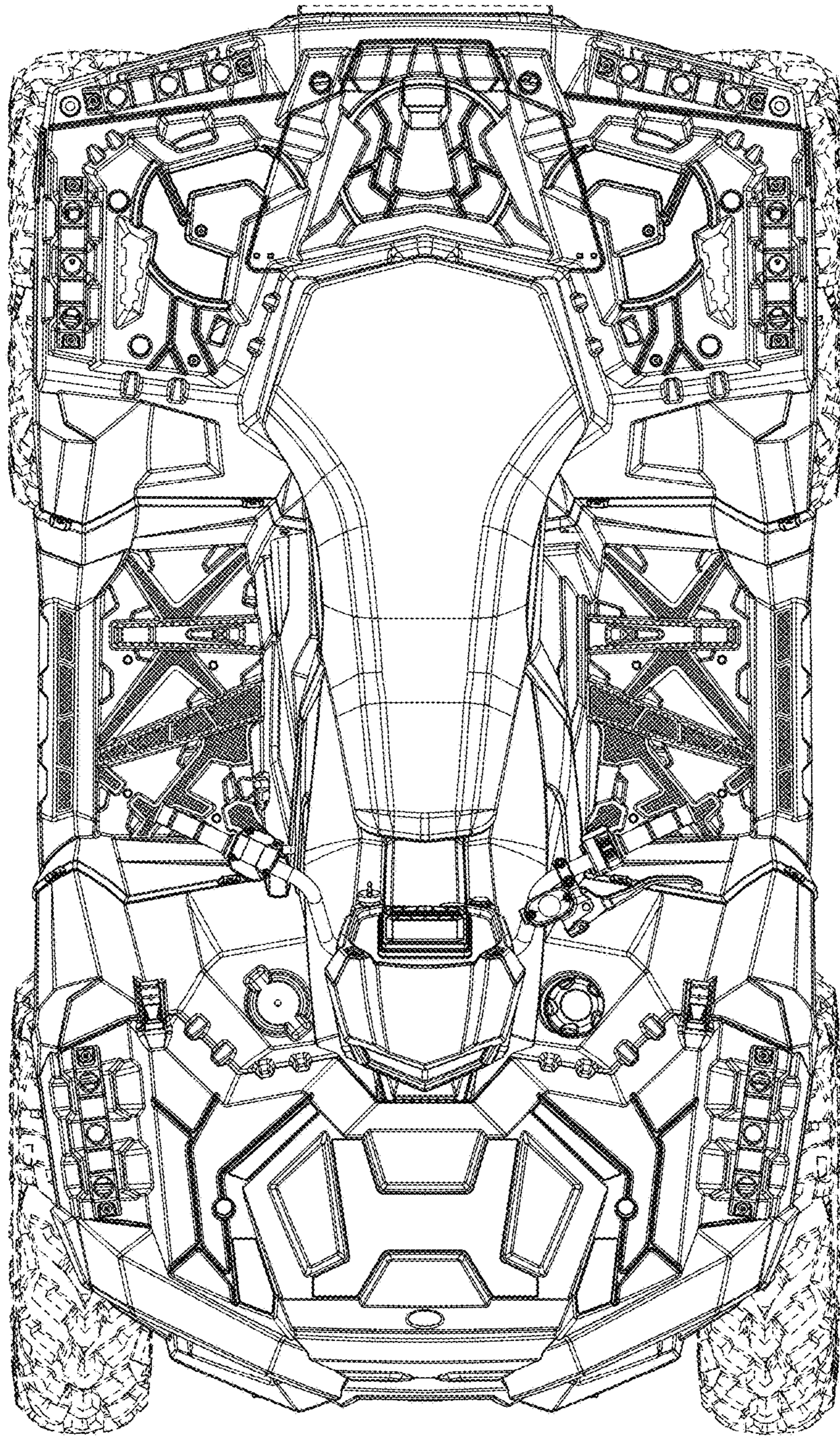

Fig. 19

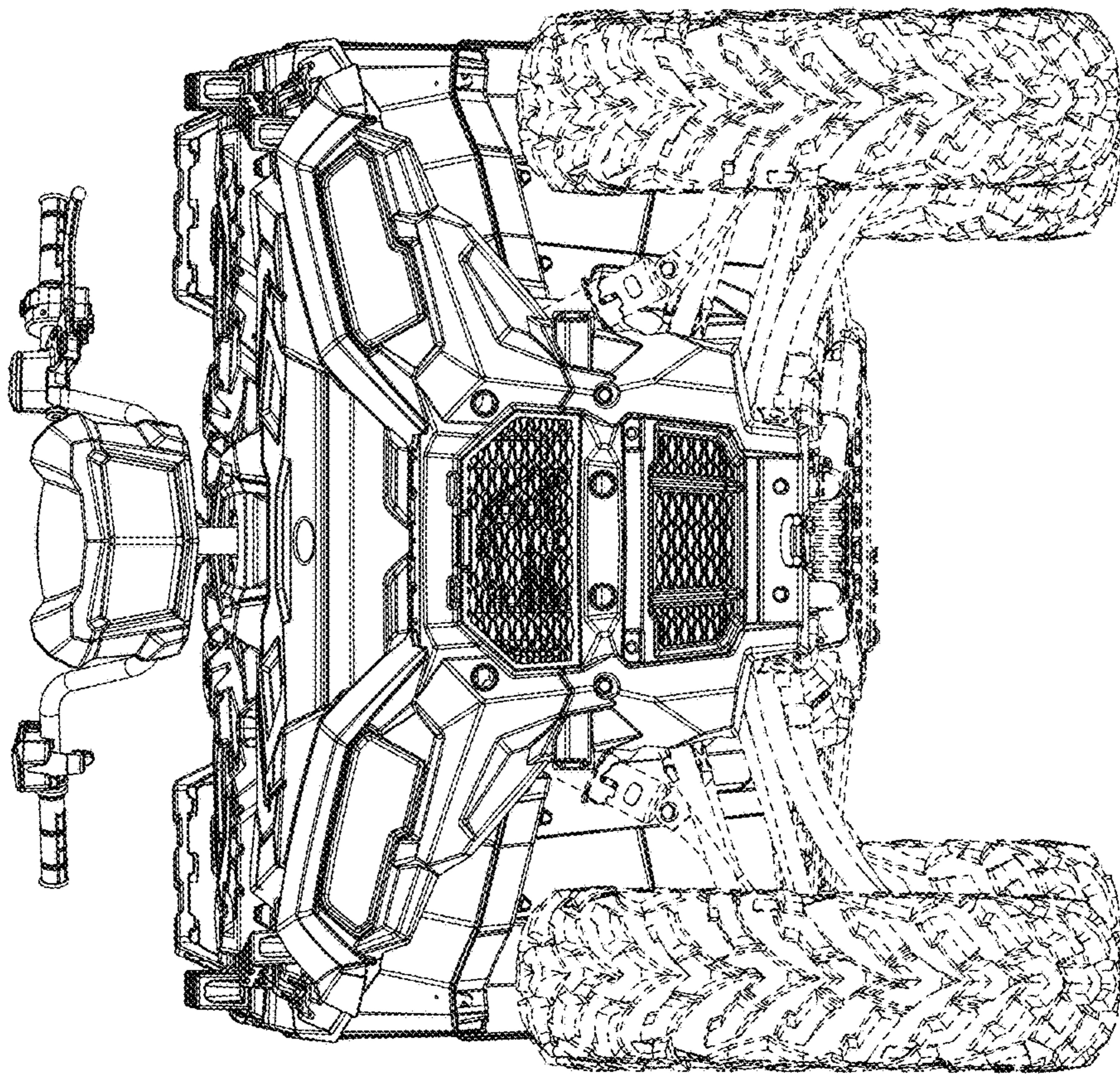

Fig. 20

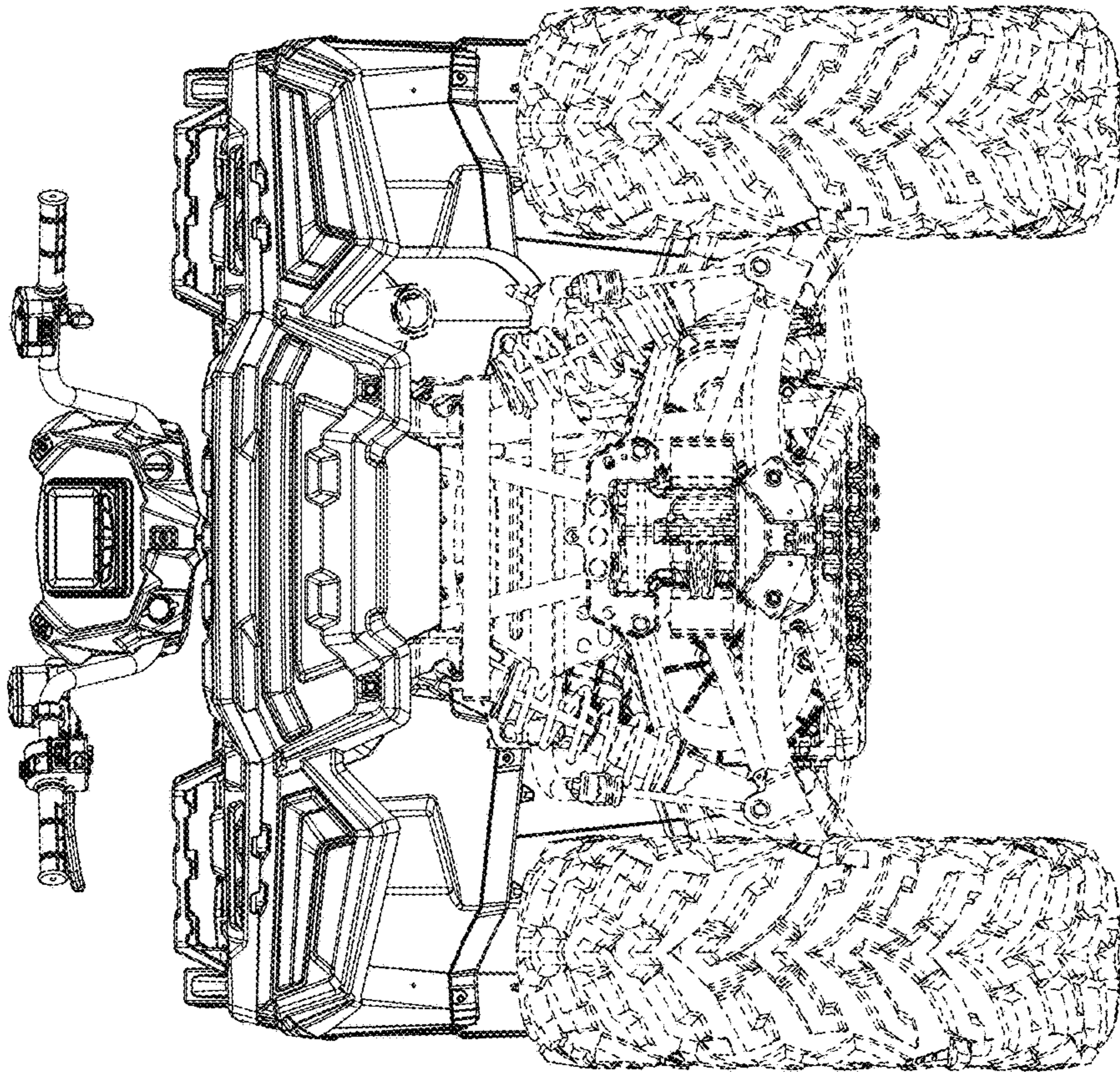

Fig. 21