



US00D827204S

(12) **United States Design Patent** (10) **Patent No.:** **US D827,204 S**  
**Lee** (45) **Date of Patent:** **\*\* Aug. 28, 2018**

(54) **DISCHARGING PLATE FOR COMPACT CONTAINER**

(71) Applicant: **PUM-TECH KOREA CO., LTD,**  
Incheon (KR)

(72) Inventor: **Do Hoon Lee,** Bucheon-si (KR)

(73) Assignee: **PUM-TECH KOREA CO., LTD,**  
Bupyeong-Gu, Incheon (KR)

(\*\*) Term: **15 Years**

(21) Appl. No.: **29/605,491**

(22) Filed: **May 26, 2017**

(30) **Foreign Application Priority Data**

Nov. 28, 2016 (KR) ..... 30-2016-0057126

(51) **LOC (11) Cl.** ..... **28-03**

(52) **U.S. Cl.**  
USPC ..... **D28/84**

(58) **Field of Classification Search**  
USPC ..... D28/8, 7, 84; D9/418, 420, 423;  
132/293, 298, 307; 222/480, 478, 565  
CPC ..... A45D 33/00; A45D 33/02; A45D 33/025  
See application file for complete search history.

(56) **References Cited**

**U.S. PATENT DOCUMENTS**

- 1,642,780 A \* 9/1927 Kole ..... A45D 33/16  
132/295
- D277,790 S \* 2/1985 Schefer ..... D28/7
- D277,791 S \* 2/1985 Schefer ..... D28/7
- D544,342 S \* 6/2007 Liebe ..... D28/78
- D544,343 S \* 6/2007 Liebe ..... D28/78

- 7,494,030 B2 \* 2/2009 Bennett ..... A45D 33/16  
132/307
- D626,289 S \* 10/2010 Lee ..... D28/82
- 8,006,707 B2 \* 8/2011 Thorpe ..... A45D 33/003  
132/307
- 8,678,222 B2 \* 3/2014 Thorpe ..... A45C 13/008  
132/293
- D756,033 S \* 5/2016 Gordon ..... D28/7
- D774,900 S \* 12/2016 Longoni ..... B65D 51/1611  
D9/420
- 2017/0318938 A1 \* 11/2017 Lee ..... A45D 40/0075
- 2018/0002070 A1 \* 1/2018 Lee ..... B65D 25/54
- 2018/0037375 A1 \* 2/2018 Lee ..... B65D 43/26

\* cited by examiner

*Primary Examiner* — Susan Bennett Hattan  
*Assistant Examiner* — Rebecca Tsehaye  
(74) *Attorney, Agent, or Firm* — Heedong Chae; Lucem, PC

(57) **CLAIM**

The ornamental design for a discharging plate for compact container, as shown and described.

**DESCRIPTION**

FIG. 1 is a front perspective view of the discharging plate for compact container showing my new design;  
FIG. 2 is a front view thereof;  
FIG. 3 is a rear view thereof;  
FIG. 4 is a left side view thereof;  
FIG. 5 is a right side view thereof;  
FIG. 6 is a top view thereof; and,  
FIG. 7 is a bottom view thereof.

The broken lines in the drawings depict parts of the discharging plate for compact container that form no part of the claimed design.

**1 Claim, 5 Drawing Sheets**

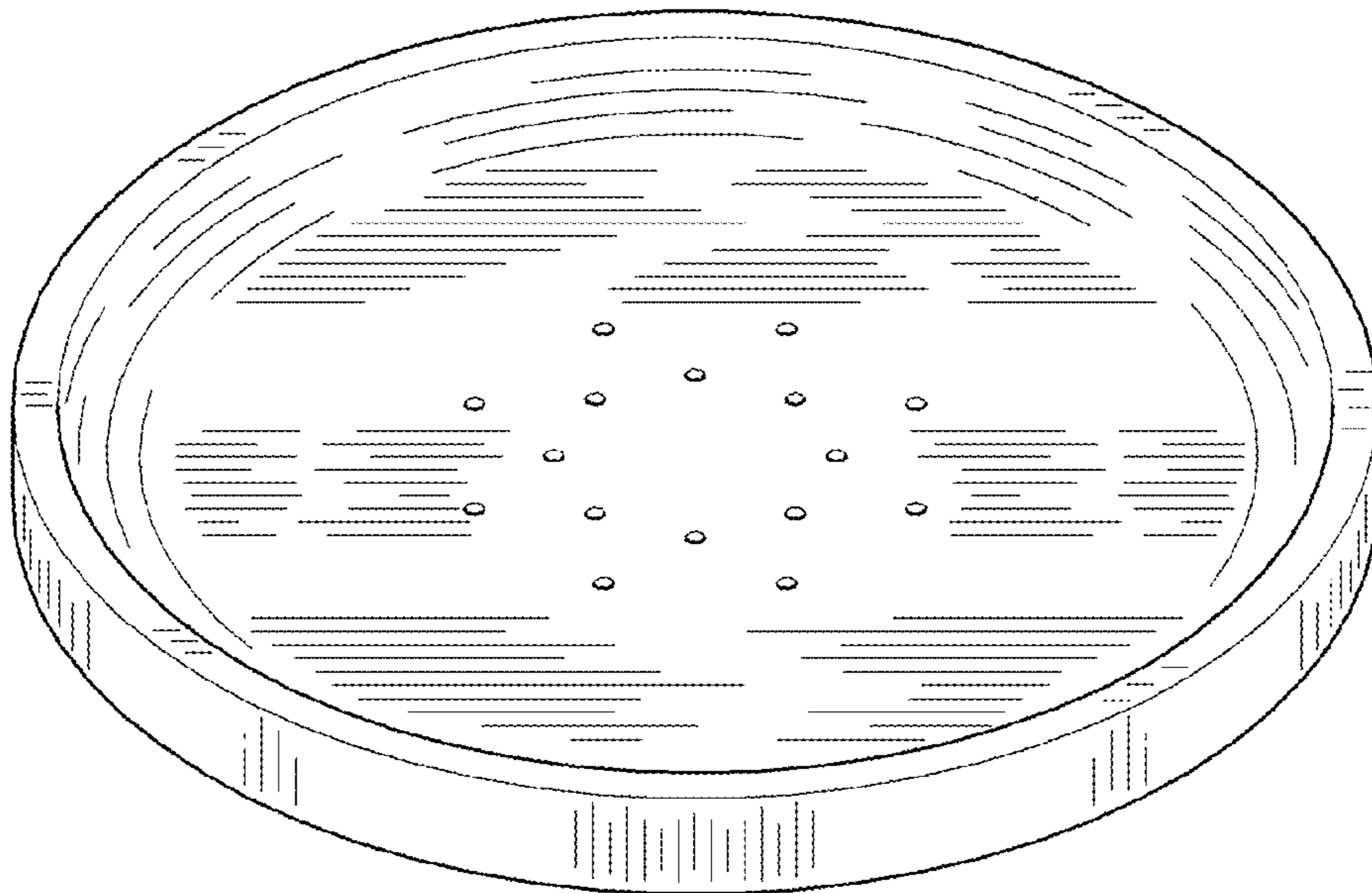

FIG. 1

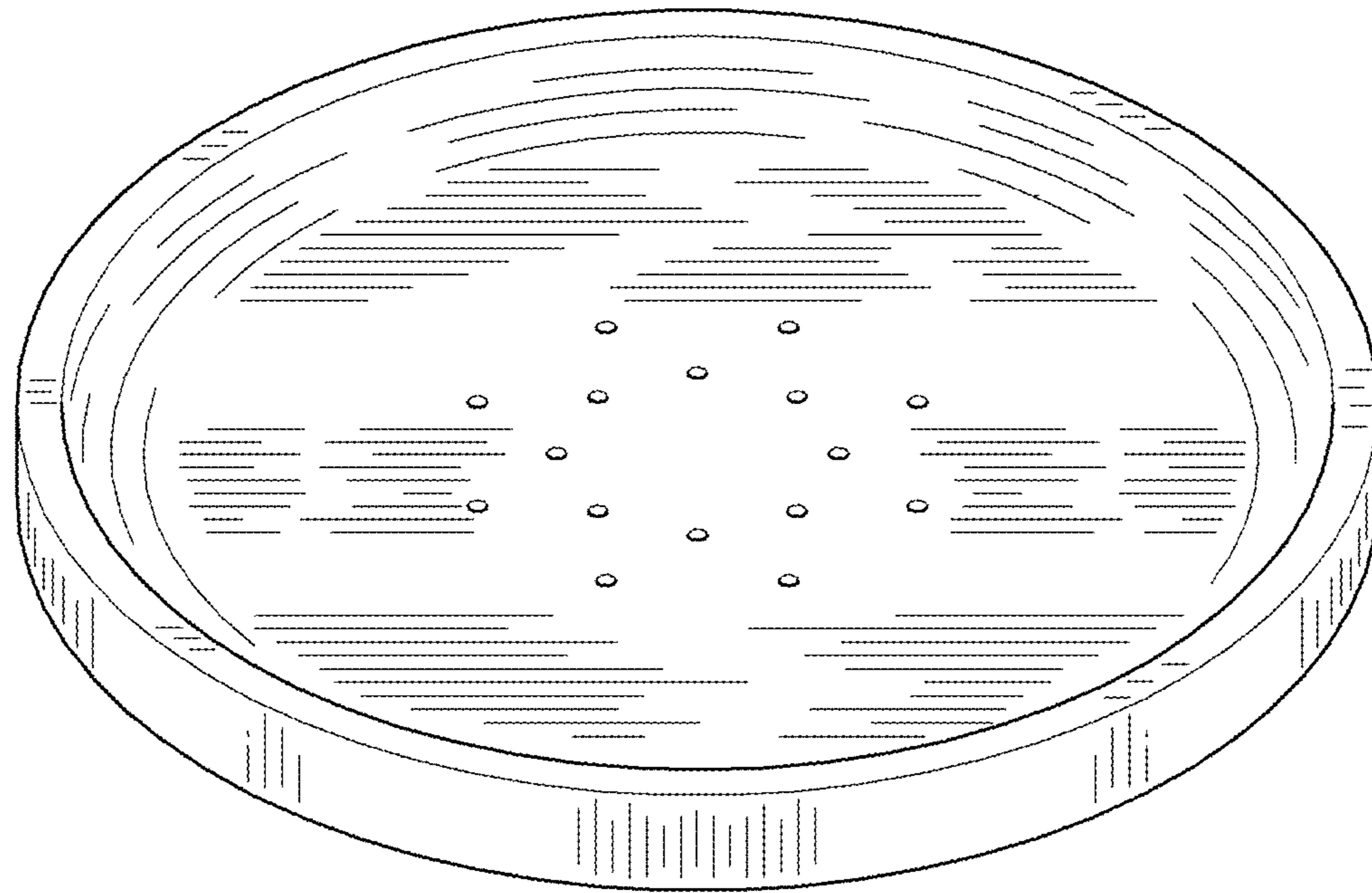

FIG. 2

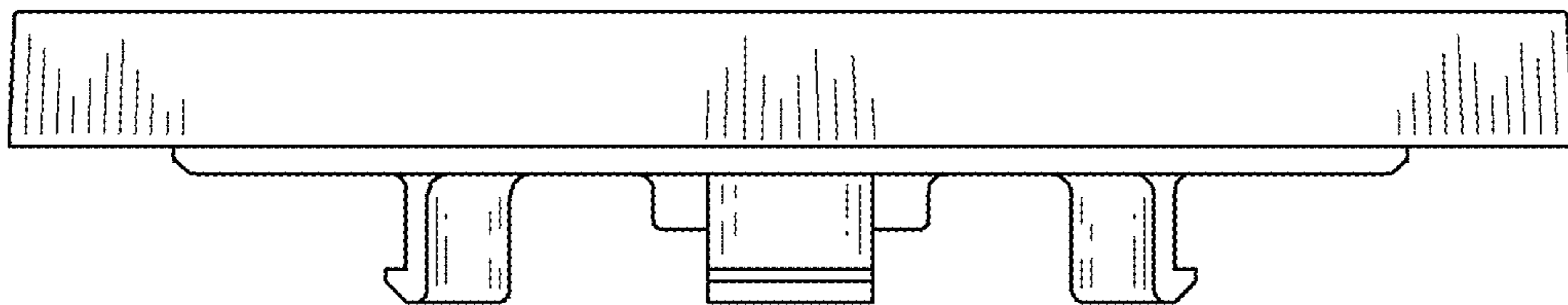

FIG. 3

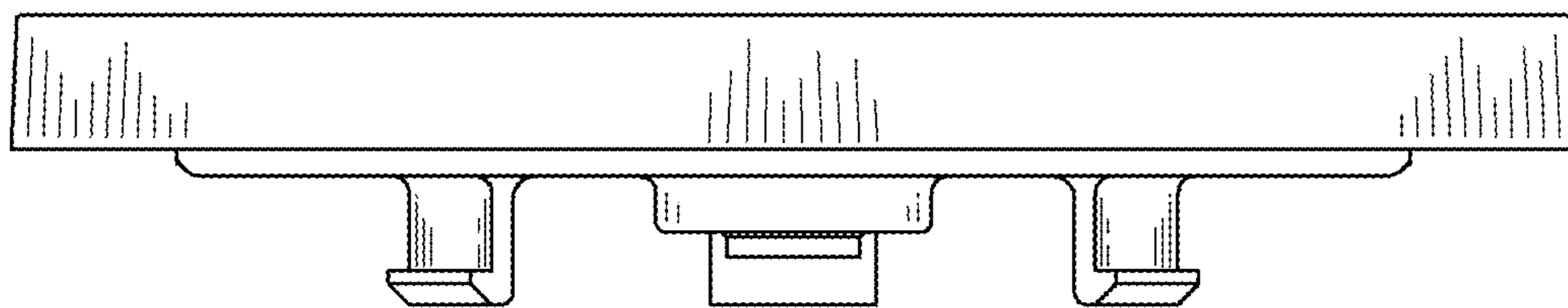

FIG. 4

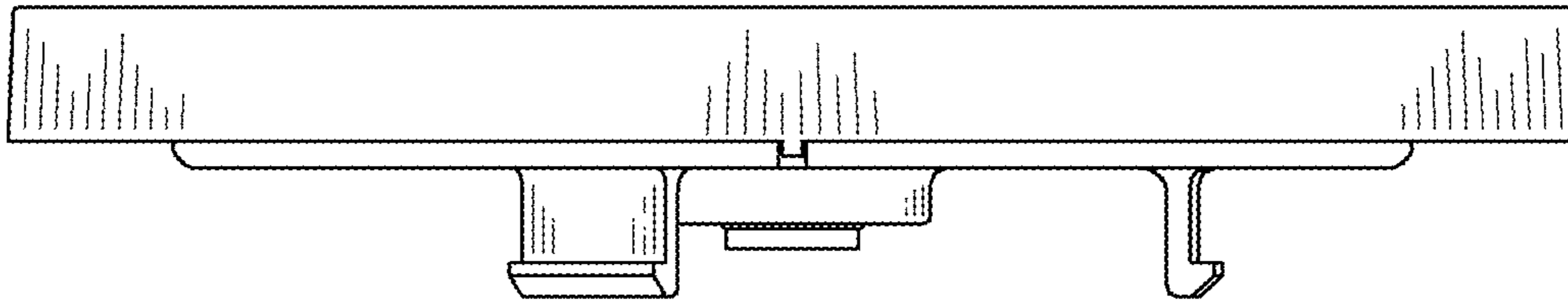

FIG. 5

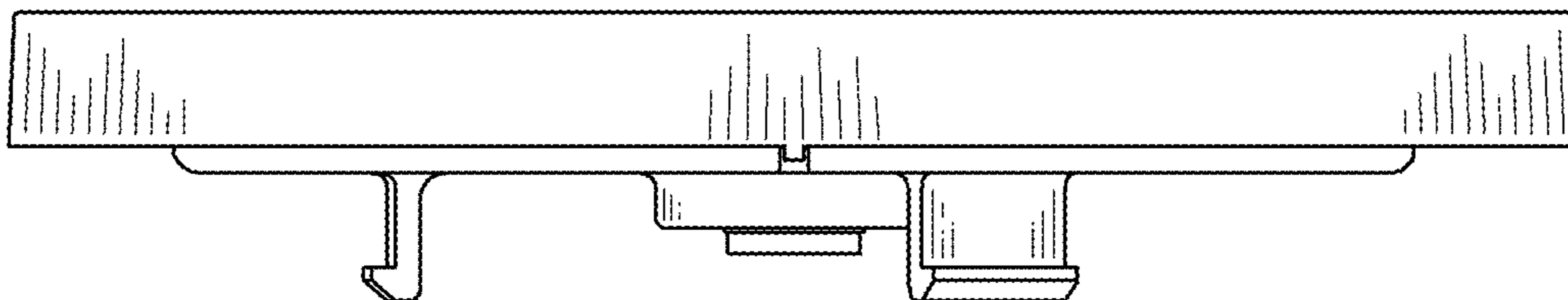

FIG. 6

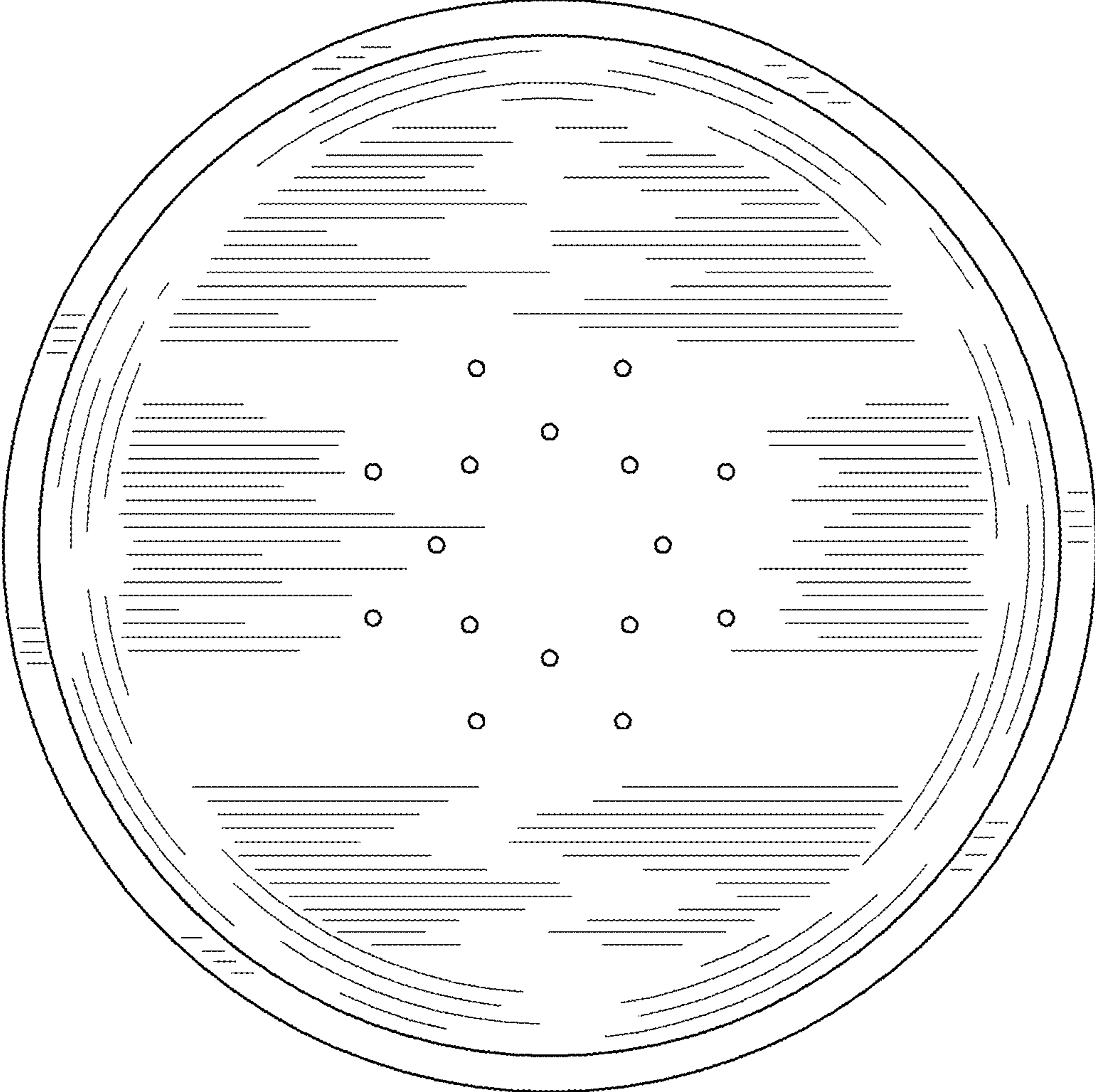



FIG. 7

