

US00D826922S

(12) **United States Design Patent** (10) **Patent No.:** **US D826,922 S**  
**Väänänen** (45) **Date of Patent:** **\*\* Aug. 28, 2018**

(54) **FEEDBACK STATION**  
(71) Applicant: **HappyOrNot Oy**, Tampere (FI)  
(72) Inventor: **Heikki Väänänen**, Tampere (FI)  
(73) Assignee: **HAPPYORNOT OY**, Tampere (FI)  
(\*\*) Term: **15 Years**  
(21) Appl. No.: **29/614,690**  
(22) Filed: **Aug. 22, 2017**

D661,291 S 6/2012 Renukanand et al.  
D671,545 S 11/2012 Guran  
D693,817 S \* 11/2013 Lim ..... D14/307  
D698,777 S \* 2/2014 Vaananen ..... D14/307  
D701,209 S \* 3/2014 Lim ..... D14/307  
D711,385 S \* 8/2014 Lim ..... D14/307  
D711,386 S \* 8/2014 Lim ..... D14/307  
D734,316 S \* 7/2015 Alvarez ..... D14/307  
D760,231 S \* 6/2016 Lim ..... D14/307  
D761,245 S \* 7/2016 Pfeiffer ..... D14/307  
D763,247 S \* 8/2016 Yopez ..... D14/307  
D782,467 S \* 3/2017 Bladwell ..... D14/307  
D795,242 S \* 8/2017 Birgeoglu ..... D14/307  
D795,858 S \* 8/2017 Iulita ..... D14/307  
D799,471 S \* 10/2017 Brown ..... D14/307  
2012/0208165 A1 8/2012 Levaniemi et al.

(30) **Foreign Application Priority Data**

Feb. 22, 2017 (EM) ..... 003762095-0002

(51) **LOC (11) Cl.** ..... **14-02**

(52) **U.S. Cl.**  
USPC ..... **D14/307**

(58) **Field of Classification Search**  
USPC ..... D14/302-307, 900-902; D13/163;  
D20/10; D21/332, 325, 369, 370;  
D99/28; D6/397, 466; 194/206;  
361/679.01, 679.02, 679.04, 679.21,  
361/679.57, 725  
CPC ..... G06Q 20/18; G06Q 20/10; G06Q 20/123;  
G06Q 20/20; G06Q 30/02; G06Q 30/06;  
A47F 9/047  
See application file for complete search history.

(56) **References Cited**

**U.S. PATENT DOCUMENTS**

D416,208 S 11/1999 Arney et al.  
D417,893 S 12/1999 Hunter et al.  
D442,560 S 5/2001 Price et al.  
D451,916 S 12/2001 Bradley et al.  
D511,160 S 11/2005 Thompson  
D597,975 S 8/2009 Ohno

\* cited by examiner

*Primary Examiner* — Austin Murphy

(74) *Attorney, Agent, or Firm* — Jacobson Holman, PLLC.

(57) **CLAIM**

I claim the ornamental design for a feedback station, as shown and described.

**DESCRIPTION**

FIG. 1 is a front perspective view of a feedback station embodying my design;  
FIG. 2 is a front elevational view rotated 45 degrees of the feedback station;  
FIG. 3 is a front elevational view of the feedback station;  
FIG. 4 is a rear elevational view of the feedback station;  
FIG. 5 is a left side elevational view of the feedback station;  
FIG. 6 is a right side elevational view of the feedback station;  
FIG. 7 is a top plan view of the feedback station; and,  
FIG. 8 is a bottom view of the feedback station.

**1 Claim, 6 Drawing Sheets**

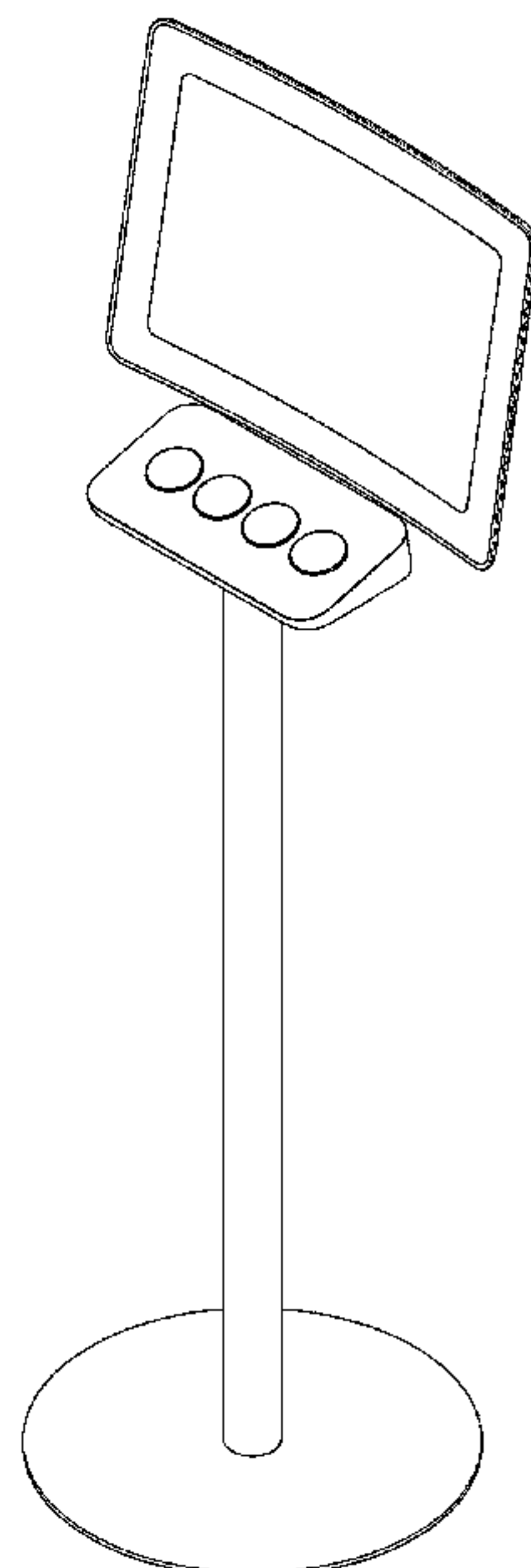

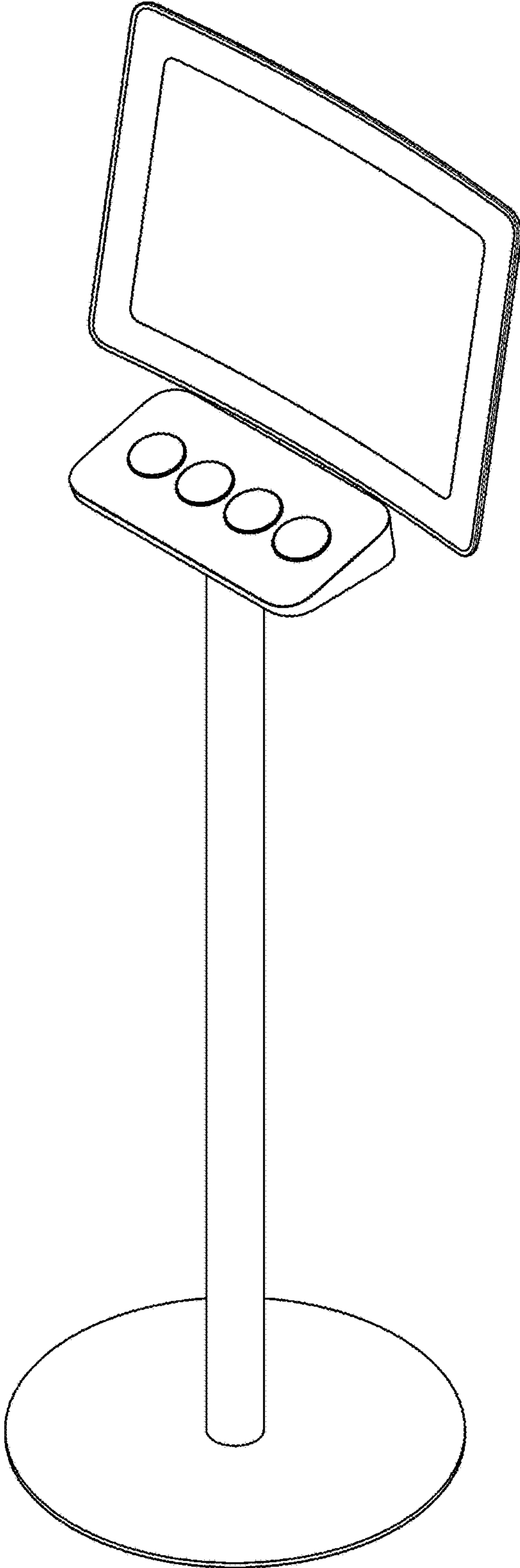

FIG. 1

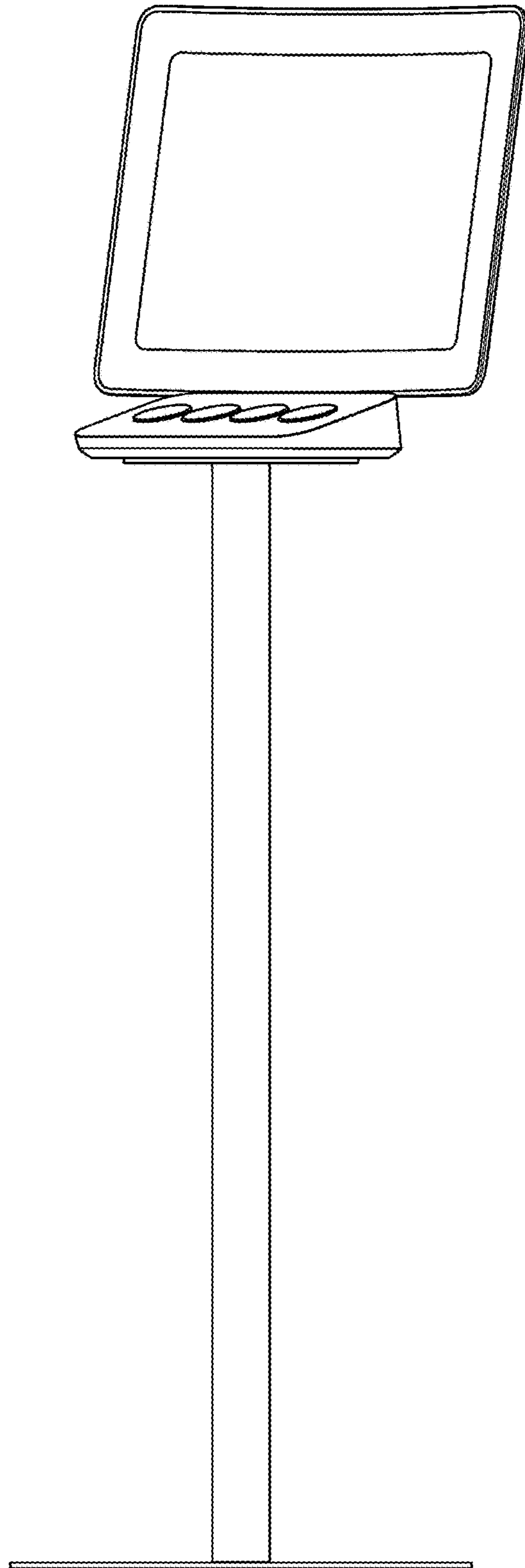

FIG. 2

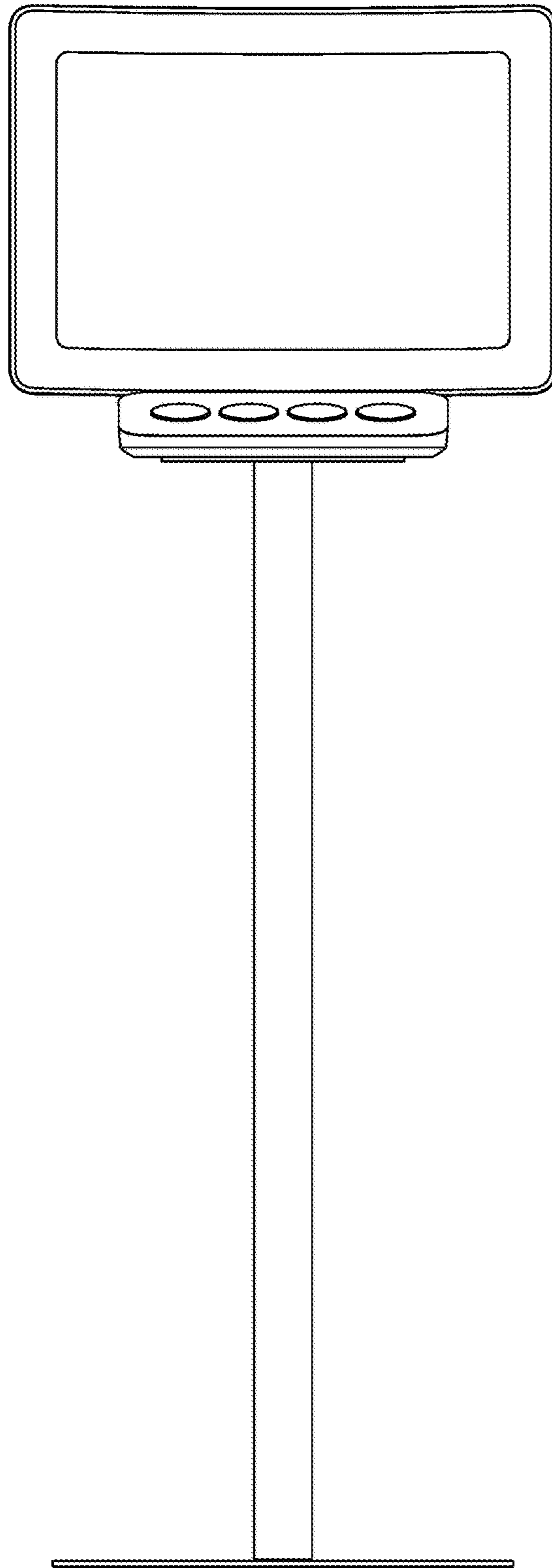

FIG. 3

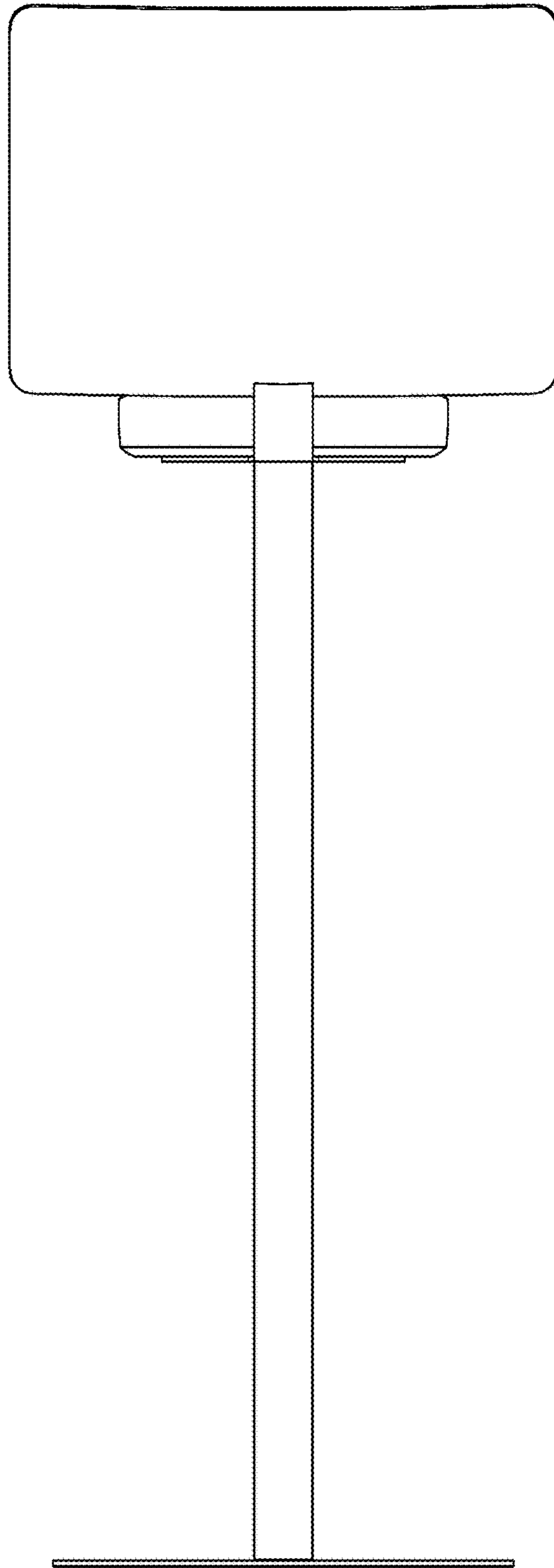

FIG. 4

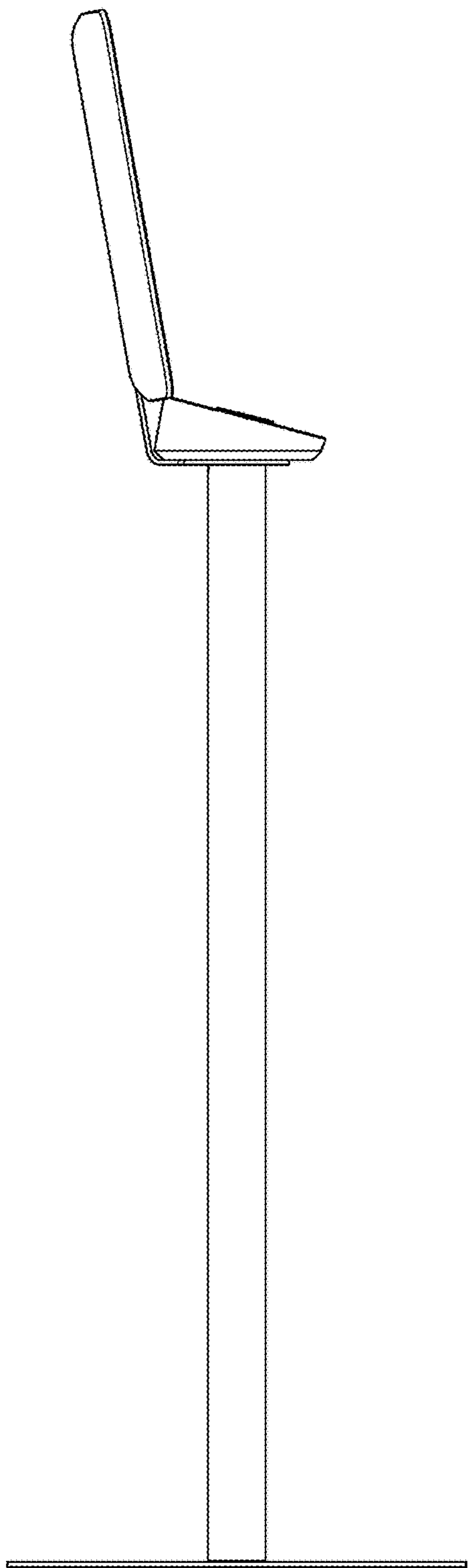

FIG. 5

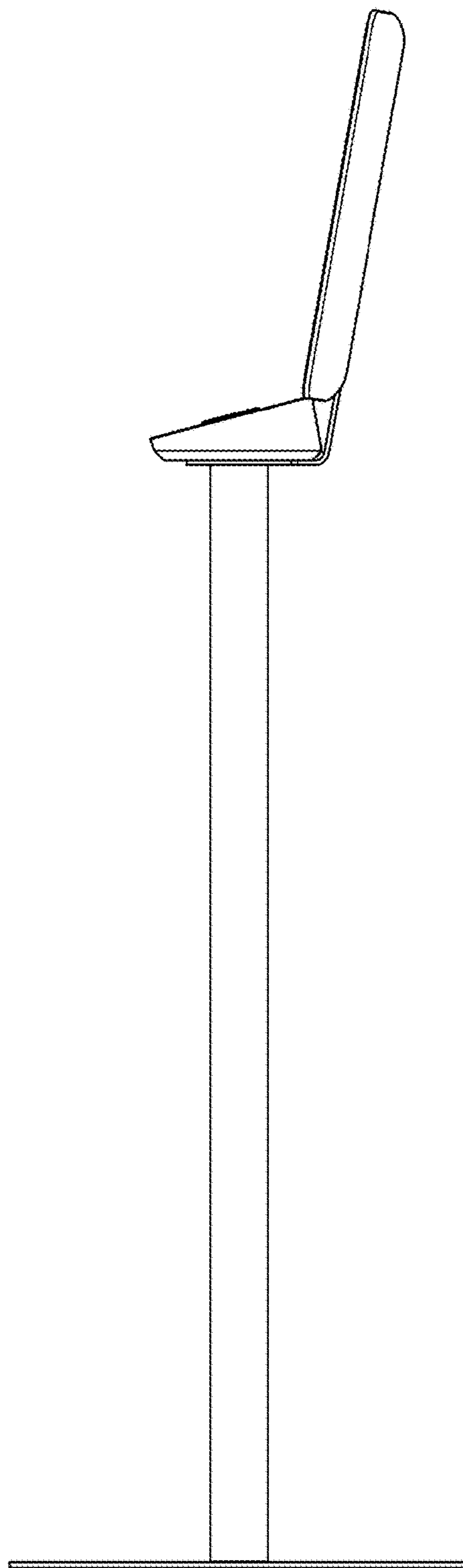

FIG. 6

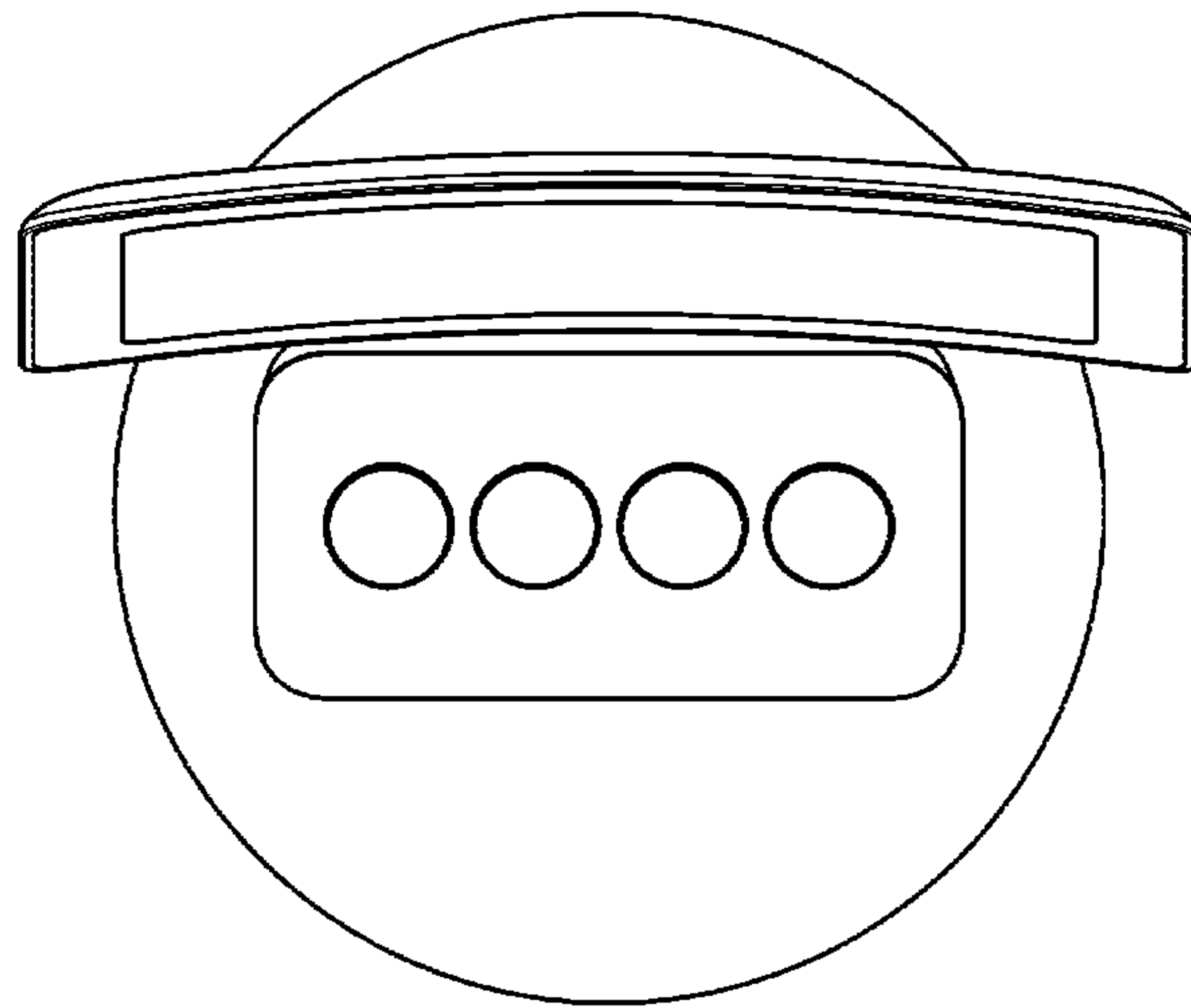

FIG. 7

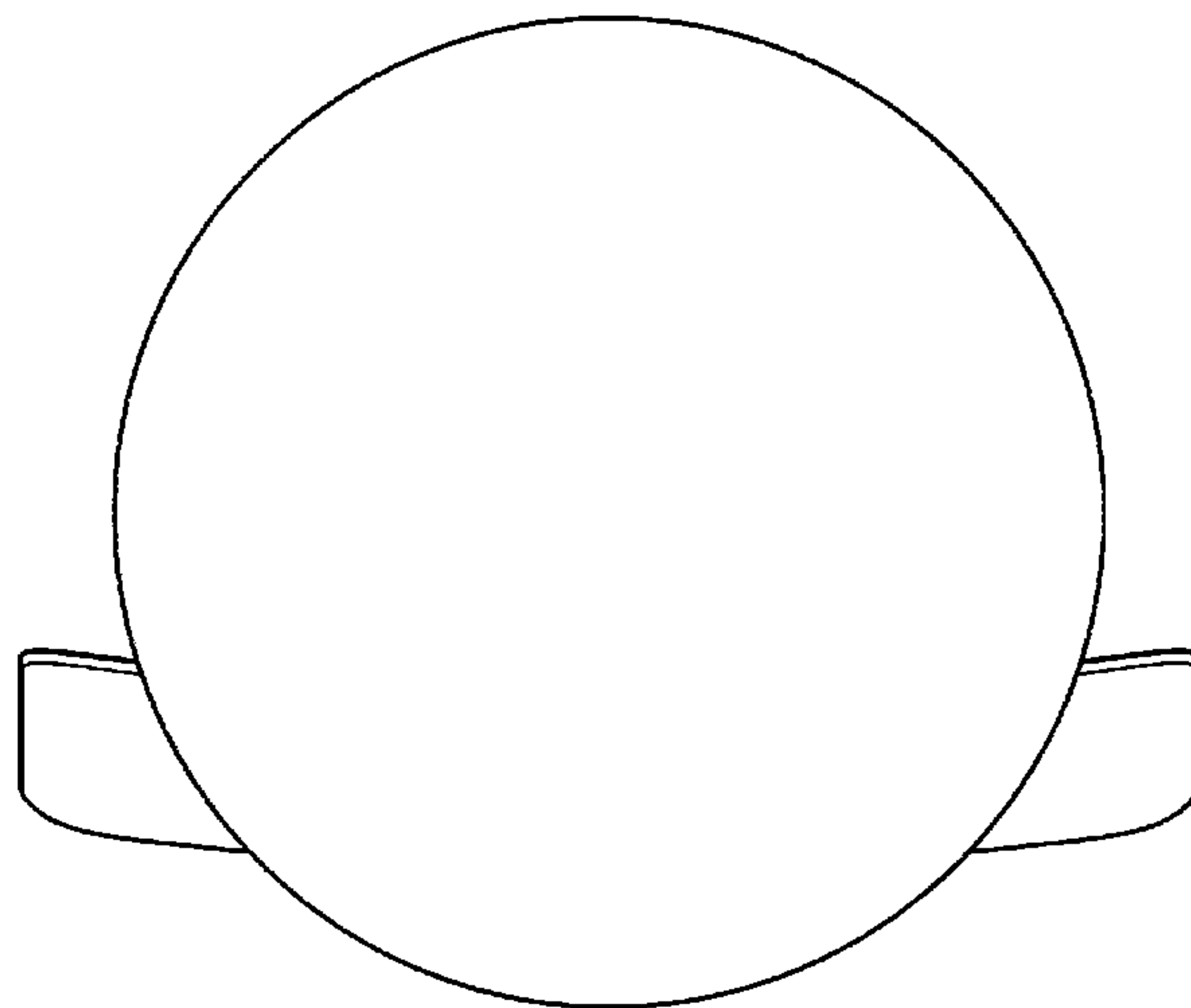

FIG. 8